

SERVICE MANUAL



**AA300
Access Air 300**

Heated Air Curtain

TABLE OF CONTENT

Topic	Page
Disclaimer	3
Serial Number Identification	3
Contact Sheet	3
Introduction	4
Product Information	
Description	4
Specifications	5
Dimensions	5
Safety Information	5
Installation Procedures	
Physical Installation	6
Electrical Installation	7
Operations	
Control Identification and Operations	8
Modes of Operation	8
Maintenance	
Maintenance Schedule	
Daily	9
Monthly	9
Yearly	9
Service	
Troubleshooting Guide (Cause and Effect)	10
Parts Lists	
Complete Parts List (Description/Part Number)	11
Drawings - Exploded Views / Schematics	12
Appendix "A" – Heater Assembly Replacement	14

DISCLAIMER

Ready Access Disclaims any Liability for any damage or harm caused to the AA300 Air Curtain, It's Operator or any other equipment however caused if the AA300 Air Curtain is repaired or serviced by anyone other than an authorized service engineer or Contrary to the manufacturers written instruction contained herein.

This manual is intended for use by the in-house or authorized field service engineers and sales representatives

The manufacturer maintains the right to update, add or issue a new service manual at any time without notice, thereby rendering all previous issues obsolete.

Please write the Serial Number and Installation Date for your drive-thru window in the spaces provided.

SERIAL NUMBER	
Date of Installation	

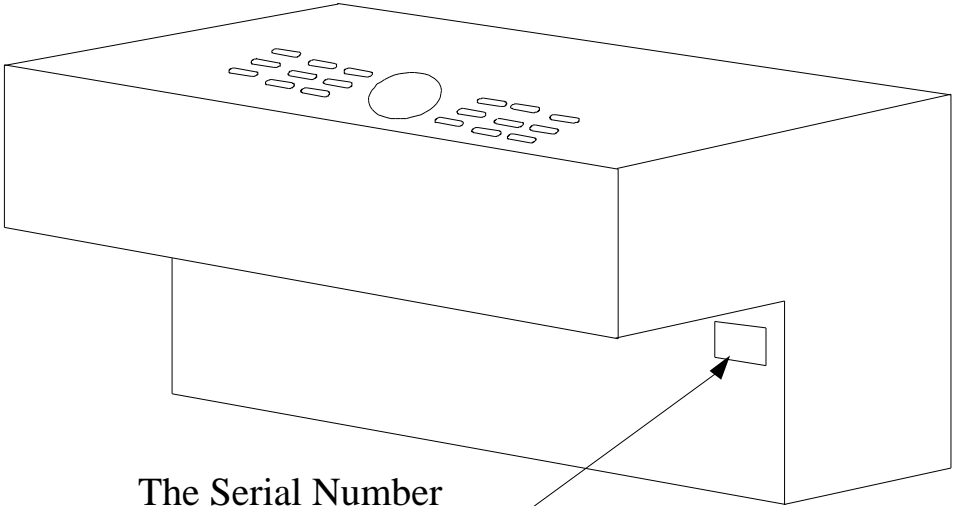

The Serial Number Nameplate Is Located on the Face Panel.

CONTACT INFORMATION

For sales and service contact

Ready Access
1815 Arthur Drive
West Chicago, Illinois 60185
Email: ready@ready-access.com

Tel: 630-876-7766
Tel: 800-621-5045
Fax: 630-876-7767
Website: www.ready-access.com

INTRODUCTION

The Ready Access AA300 Pass-Thru Air Curtain System is designed to be an integral part of your drive-thru operation by providing comfort for both operator and customer during the coldest of days as well as satisfying health department codes for fly fan application.

PRODUCT INFORMATION

Modes of Operation

The Ready Access AA300 Pass-thru Air Curtain System is versatile in function and design, offering operators four separate modes of operation.

- * Outside warm air flow only
- * Inside warm air flow only
- * Both outside and inside warm airflow
- * Outside fly fan operation only

Features and Benefits

Satisfies health department requirements for "Fly Fan" applications while it reduces and deflects the amount of outside wind blowing into the building. This also reduces heating and air-conditioning loss as well as reducing unwanted environment factors such as dust and exhaust fumes from entering the building. Acts as a fly fan to deter insects from entering the building during warm weather conditions.

Provides the owner/operator with a stable, comfortable working environment for all crewmembers. Reduces Drive-Thru operation expenses by diminishing employee turnover.

Unique Design

The AA300 Air Curtain System is the only system on the market today that offers an outside and inside heated airflow. It is designed for use with any flush mount window.

Quality Construction

The exterior housing of the AA300 Air Curtain System is manufactured using bronze or clear anodized aluminum.

Fully Assembled, Ready to Install

The Access Air 300 system is shipped completely pre-assembled and ready for installation, lowering installation costs. Normal installation for new store construction takes less than two hours.

Three to Five Day Shipping

Ready Access will ship any standard Access Air 300 System in 3 to 5 days from receipt of order.

Warranty and Service Support

Your Access Air 300 System comes with a one year limited warranty on parts and labor. In addition, each Pass-Thru Air Curtain System is backed by a nationwide service organization.

AVAILABLE OPTIONS

Power coat painting is available upon request for a wide range of custom colors.

SPECIFICATIONS AND PERFORMANCE

Model Number	Unit Voltage		Heater Watts	Actual Unit Amps	Air Velocity	Dimensions In Inches W x H x D	Weight In Shipping Carton
	USA	International					
AA300	208/240 VAC 60Hz Single Phase	220/240 VAC 50/60 Hz Single Phase	7100 W	32 A	600/800 FPM at Nozzle	See Below	60 lbs

Dimensions

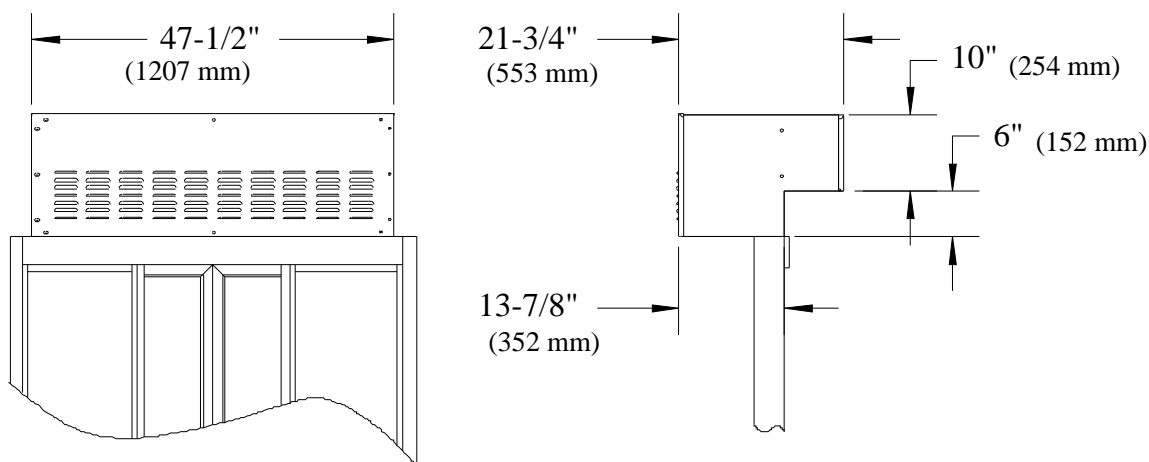

Figure 1

SAFETY INFORMATION

WARNING: To avoid the risk of fire, Electric Shock or injury to persons, observe the following:

Before servicing or cleaning the unit, switch the power off at the mechanical switch near the unit (Installed by an Electrician) or the electrical entry service panel/circuit breaker. (Load Center) **OSHA LOCK OUT – TAG OUT** procedures are to be observed to prevent power from being switched on accidentally.

Any Installation and / or Electrical work must be done by **QUALIFIED** persons in accordance with all applicable codes / standards and manufacturers recommendations and specifications.

DO NOT insert fingers and / or foreign objects into the Air Curtain.

DO NOT block or tamper with the unit in any manner while it is in operation.

This product must not be used in Potentially Dangerous locations such as Flammable, Explosive Chemical – laden environment.

DO NOT attach duct work to this product or attempt to use it as a make-up air heater. Such use voids the warranty and may create unsafe conditions.

Installation Procedures

PHYSICAL INSTALLATION

Before you begin installing your Ready Access Air Curtain, you must determine what type of installation will be required. Wood Frame, Masonry Framing, etc. See the illustration below to determine your rough opening size and mounting.

Warning: Two people are required for the lifting and installation of the air curtain.

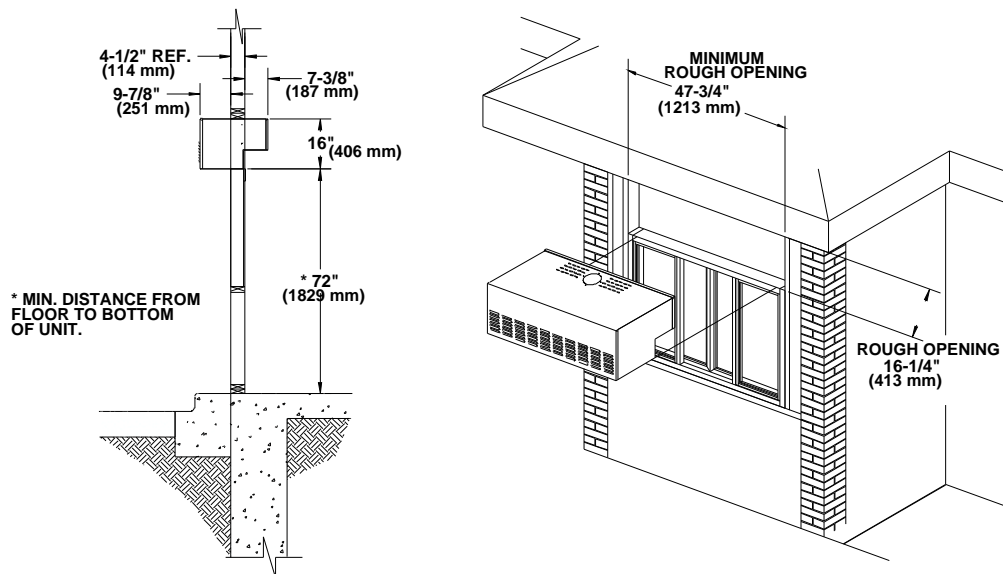

Figure 2

CONFIRM THAT THE CUSTOMER-SUPPLIED FRAME IS MADE TO ACCOMMODATE THE DIMENSIONS AS ILLUSTRATED ABOVE.

Confirm that AC power has been run and is ready for connection to the Air Curtain.

Check shipping carton for any shipping damage and remove Air Curtain from the carton.

Check Air Curtain for any shipping damage.

Once the application has been determined, check the daylight opening of the frame being used. The opening dimensions should be 47 ³/₄" wide x 16 ¹/₄" high.

The electric should be installed from the breaker box (Load Center) to the Air Curtain opening before the installation.

Window Air Unit

1. Remove the Outside cover from the unit.
2. Position the unit as shown in Figure #2. Note the position of the unit. The inside surface should be flush with the window

From the Outside

3. Secure the unit to the window with the 6 – self-tapping screws. (Provided)
4. Secure the unit to the building with the 4 - #12 x 3" long screws. (Provided)

NOTE: Clearance holes are not provided due to different building constructions.

Electrical Installation

All power must be connected and wired by a **qualified electrician** and must be in compliance with all state and local codes.

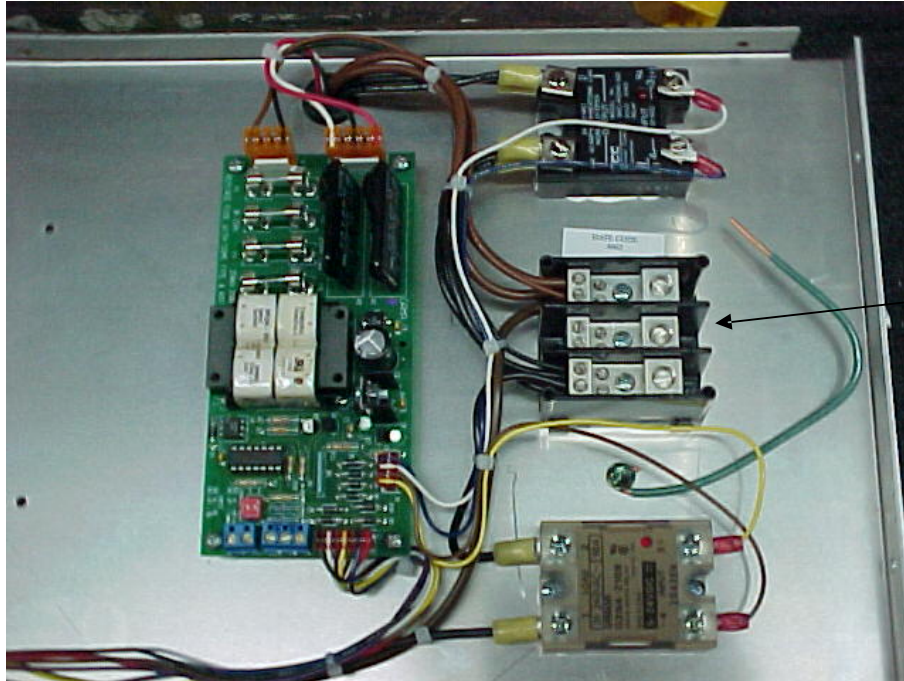

Terminal Block
AC Input
Match wires
Color for Color

The incoming AC power line must be connected to the terminal block located in tray. (Per Standard electrical code.) The green “grounding” wire is to be attached to the frame of the unit.

WARNING: Use only 208/240 VAC – 60Hz / Single Phase source with a dedicated 40 Amp circuit.

WARNING: This must be a dedicated circuit. Other electrical equipment must not share the same line from the 40Amp circuit breaker.

WARNING: Turning off the front panel rocker switches does not remove the 208/240 volts of electrical power from the unit

WARNING: To disconnect the power completely from this unit, turn OFF the mechanical switch near the unit (Installed by an Electrician) or the electrical entry service panel/circuit breaker panel (Load Center) for this unit.

OSHA LOCK OUT – TAG OUT procedures are to be observed to prevent power from being switched on accidentally.

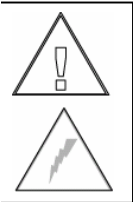

Initial Window Operation

Control Identification and Operation



Switch Identification	Function
Winter / Summer (Main)	Switches between the three modes of operation.
Outside Heat	Enables the “Outside Heater” for Winter operation
Inside Heat	Enables the “Inside Heater” for Winter operation.

Modes of Operation

The AA300 has three modes of operation. Shutdown, Summer and Winter.

Shut Down:

All switches are in the “OFF” position.

The unit has no operations.

Summer

The Main switch is in the “Summer” position.

The unit functions as a “Fly Fan”.

Winter

The Main switch is in the “Winter” position.

The unit functions as a “Fly Fan”.

Turn on the “Inside” or “Outside” heater switch to the desired setting.

Provides a heated Air Curtain to inside and/or the outside of the window.

If the AA300 does not operate correctly, go to the troubleshooting guide in this manual.

If the AA300 still do not operate properly, then call Ready Access at

1-800-621-5045

Each operator must read the operations manual before operating the unit.

Maintenance

Maintenance Schedule

Scheduled maintenance should be performed on a regular basis. This is to assure proper operation and performance of the AA300 Air Curtain.

DAILY

Check the air vents and ducts for foreign materials. (Anything that might cause restricted air flow or damage to the air curtain.)

MONTHLY

Follow safety procedures before opening the unit.

Check the interior of the unit for any build up of any foreign materials using a dry cloth.

NOTE: KEEP ANY LIQUIDS OFF THE INTERIOR COMPONENTS.

Clean moving parts and lubricate with silicone or Teflon spray.

NOTE: Do **NOT** use Grease or Oils. Do **NOT** lubricate the motor clutch assembly.

Semi Annual (6 Months)

Check all electrical and mechanical parts for proper operations

YEARLY

Have a service technician come in and perform a maintenance check on the unit.

IF NEEDED, CONTACT YOUR READY ACCESS SERVICE AGENT FOR SERVICE.

SERVICE

Issue	Probable Cause	Resolution
Both Heaters Inoperable. Switches do not illuminate.	No power to the unit.	Check / Reset the main circuit breaker or switch.
	Fuse 1 and/or 2 is blown.	Replace the blown fuse/s.
	Defective power supply.	Replace the power supply.
	Power supply output is shorted.	Find and correct short.
Outside Heat Inoperable. Fan does not run. Switches Illuminate Normally.	If Relay #2 LED is "ON". Blown Blower Fuse or Defective Blower.	Replace the blown fuse/s. Replace the blower.
	If Relay #2 LED is "OFF". Defective timer 1, Relay #2 or #3 Unit went into thermo Overload.	Replace the defective component.
Outside Heat Inoperable. Outside Fan Running.	Defective Relay #3.	Replace relay #3.
	Defective Heating Element.	Replace the heating element.
Inside Heat Inoperable. Fan does not run. Switches Illuminate Normally.	Defective relay #1.	Replace relay #1.
Inside Heat Inoperable. Inside fan runs. Switches Illuminate Normally.	Defective Quartz Heater.	Replace the quartz heater.
Fan does not run in the Summer position.	Window is CLOSED.	Open the window.
	Window switch is not wired correctly.	Check the schematic and correct wiring
	If Relay #2 LED is "ON". Blown Blower Fuse or Defective Blower.	Replace the blown fuse/s. Replace the blower.
Outside Fan does NOT shut off in the Summer position.	Window switch is not wired correctly.	Check the schematic and correct wiring
	Timer #1 is defective	Replace Timer #1
	Defective Relay #2	Replace Relay #2
Outside Fan runs when the door/s are closed and shuts off when the door/s are open.	Window switch is not wired correctly.	Check the schematic and correct wiring

Parts Lists

Complete Parts List (Description/Part Number)

Description	Current Part Number	Previous Part Number	Status	Note
Bit - Square Drive - Security	20010006	N/A	Current	
Blower Assembly (New Style) - Dual Speed	85028000	39927801,200 10015	Current	
Blower Assy - Kit (Old Style AA300)	85127800	39927800	Current	
Cover - Outside - Bronze	30100201	N/A	Current	
Cover - Outside - Champagne	30100203	N/A	Current	
Cover - Outside - Clear	30100202	N/A	Current	
Fan - Kit - Muffin	85127900	39927900	Current	
Fuse, .250 AMP (2 per unit)	20110524	N/A	Current	
Fuse, 1.0 AMP (1 per unit)	20110523	N/A	Current	
Harness Assy Kit - Brz	85129001	39929001	Current	
Harness Assy Kit -Clr	85129002	39929002	Current	
Heater Assy - Kit - L-R (For Dual Speed Blower)	85028120	N/A	Current	
Heater Assy - Kit - L-R (Heating element)	85127720	39927720	Current	
Heater Assy - Kit - R-L (For Dual Speed Blower)	85028110	N/A	Current	
Heater Assy - Kit - R-L (Heating element)	85127710	39927710	Current	
Panel Air Shield L/R	30227520	N/A	Current	
Panel Air Shield R/L	30227510	N/A	Current	
PCB CONTROLLER - AA300 (New Style)	85003000	N/A	Current	
Quartz Lamp - Kit	85129100	39929100	Current	
Relay - 40 Amp	20110513	N/A	Current	
Relay - Omron - 10 Amp - 2 pet unit.	20110528	N/A	Current	
Rivet	10180009	N/A	Current	
Switch Kit - Summer - Air Shield	85129200	39929200	Current	
Thermostat - Selco Kisco	20110017	N/A	Current	
Timer Board Kit	85129300	39929300	Current	
Torx Bit - T25 Security	20010001	N/A	Current	

Drawings

Exploded Views

Page	Part Number If Applicable	Description
12	N/A	Unit – Exploded View

Schematics

Page	Part Number If Applicable	Description
13	50010161-D	Wiring Diagram (New Version)
14	N/A	Wiring Diagram

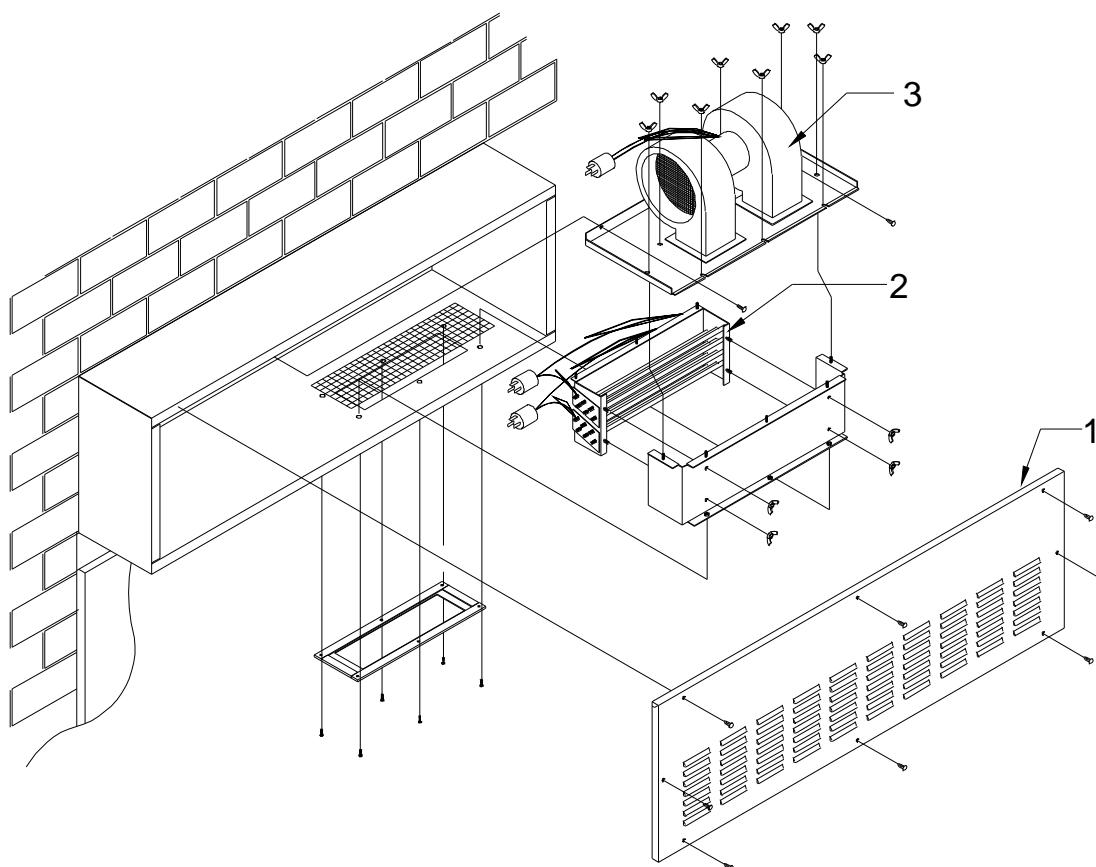

REF ID #	PART NUMBER	DESCRIPTION	REF ID #	PART NUMBER	DESCRIPTION
1	30100201	Cover – Outside – BR	2	See Parts List	Heater Assy Kit R/L
1	30100202	Cover – Outside – CL	2	See Parts List	Heater Assy Kit L/R
1	30100203	Cover – Outside - Champ	3	See Parts List	Blower Assembly Kit

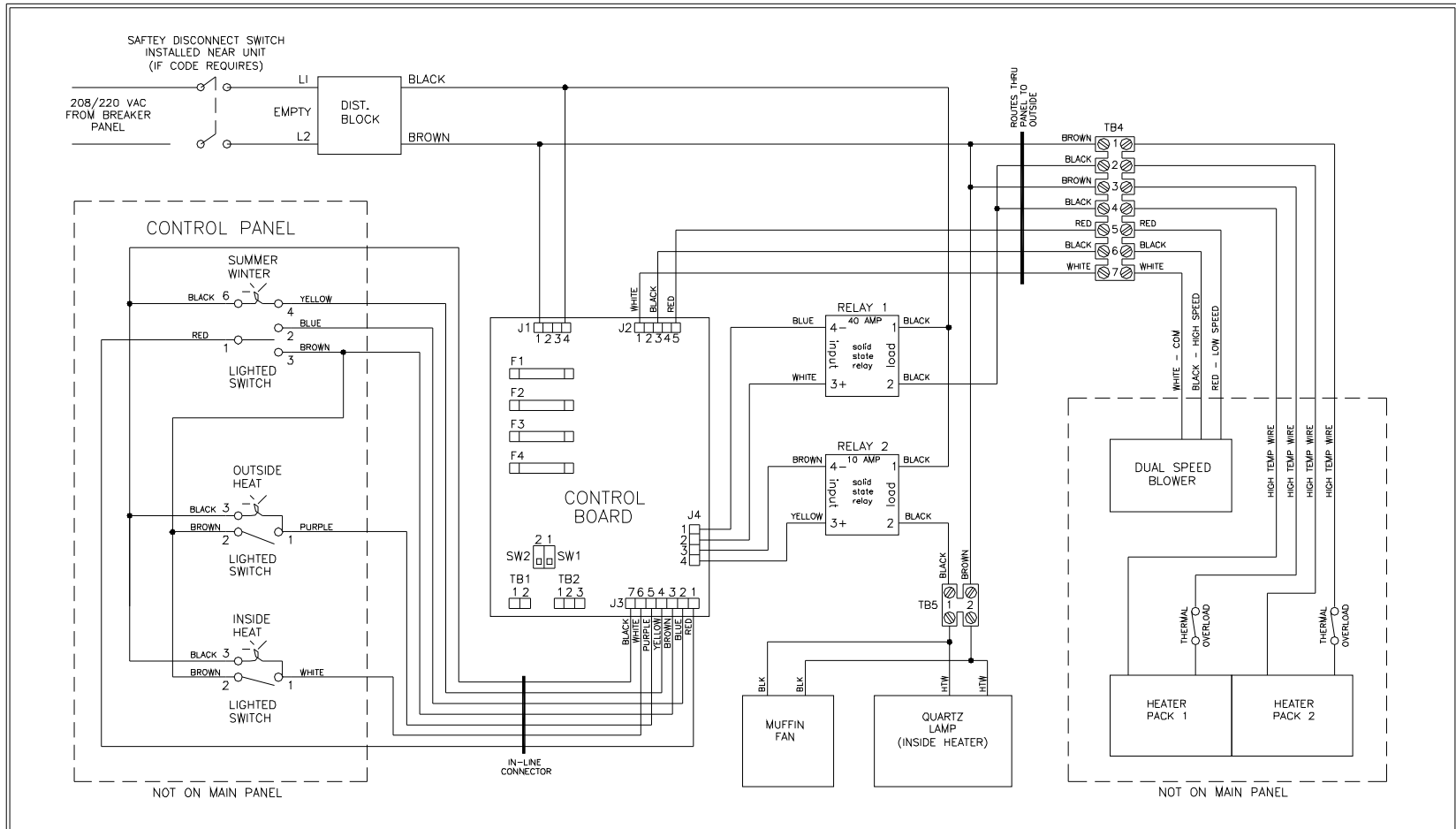

<p>FUSE INFORMATION:</p> <p>F1 = FUSE 1 - 3A 250V (BLOWER & CONTROL CIRCUIT)</p> <p>F2 = FUSE 2 - 3A 250V (BLOWER & CONTROL CIRCUIT)</p> <p>F3 = FUSE 3 - 250mA 250V (CONTROL BOARD)</p> <p>F4 = FUSE 4 - 250mA 250V (CONTROL BOARD)</p>	<p>TERMINAL BLOCK 1 (TB1):</p> <p>USED FOR CONNECTING AA300 TO READY ACCESS FULLY-AUTOMATIC WINDOW UNIT CONTROL BOARD.</p> <p>PIN 1 = RED (+)</p> <p>PIN 2 = BLACK (-)</p> <p>FULLY-AUTOMATIC CONNECTION:</p> <p>MCS CONNECTOR ON WINDOW CONTROLLER.</p> <p>PIN 1 = BLACK (-)</p> <p>PIN 2 = (NOT USED)</p> <p>PIN 3 = RED (+)</p> <p>M.O.E.R CONNECTION:</p> <p>J2 CONNECTOR ON M.O.E.R. UNIT. (SAME AS MCS CONNECTOR)</p>	<p>TERMINAL BLOCK 2 (TB2):</p> <p>USED FOR CONNECTING AA300 TO READY ACCESS MANUAL WINDOW UNIT MICRO-SWITCH OR PROXIMITY SWITCH.</p> <p>MICRO SWITCH:</p> <p>PIN 1 = (NOT USED)</p> <p>PIN 2 = BLACK - N.O.</p> <p>PIN 3 = RED - COM</p> <p>PROXIMITY SWITCH:</p> <p>PIN 1 = BROWN - 12VDC</p> <p>PIN 2 = BLACK - OUTPUT</p> <p>PIN 3 = BLUE - GROUND</p>	<p>SWITCH 1 (SW1):</p> <p>WINTER MODE SELECT:</p> <p>"ON" = OUTSIDE HEAT ALWAYS ON REGARDLESS OF WINDOW INPUTS.</p> <p>"OFF" = OUTSIDE HEAT STAYS ON FOR 15 MINS. AFTER WINDOW CLOSES. (REQUIRES TB1 OR TB2 CONNECTION)</p> <p>SWITCH 2 (SW2):</p> <p>WINDOW INPUT SELECTOR:</p> <p>"ON" = AUTOMATIC OR M.O.E.R. WINDOW</p> <p>"OFF" = MICRO SWITCH OR PROXIMITY SWITCH.</p> <p>NOTE: IF NO WINDOW IS CONNECTED, SET SWITCH TO "OFF" POSITION.</p>
---	--	--	---



1815 Arthur Drive ■ West Chicago, Illinois 60185
 800-621-5045 ■ 630.876.7766 ■ Fax. 630-876-7767

AA300 DUAL SPEED WIRE DIAGRAM

50010161. REV. D

Appendix "A"

Replacement Procedures to Follow When Replacing the Heater Assembly

WARNING! To reduce the risk of fire, electric shock or injury to persons, observe the following:

1. Before servicing unit, switch power off at the mechanical switch near the unit (installed by electrician) or electrical entry service panel / circuit breaker. **OSHA Lock Out-Tag Out** procedures are to be observed to prevent power from being switched on accidentally.
2. Any installation and/or electric work must be done by **Qualified persons** in accordance with all applicable codes / standards and manufactures recommendations.

Tools Needed: T25 Torx Tamper Proof Bit (for removing covers)
¼" Driver (For removing blower assembly from panel)
Pliers (Aid in removing tight wing nuts from blower assembly)
Wire cutters/strippers
Electrician Tape

1. Remove the outside cover from the unit. (12 screws) (Item No.1)
2. Unplug all electrical twist and lock plugs to the heater assembly and blower from the panel. (Items No.12 & 13)
3. Remove the wire mesh cover. (6 Torx screws) (Item No.4)
4. Remove the blower assembly (Item No.9) by unscrewing the (8) wing nuts (Item No.7) and the (2) ¼" Hex head screws (Item No.10) from the panel. Remove the blower assembly from the unit and place aside in a safe place. Do not allow the blower to get wet.
5. Remove the Heater Assembly Cover (Item No.6) by unscrewing the (4) wing nuts. (Item No.7)
6. Turn the heater assembly so the back of the assembly is facing up exposing the blue wires to the thermostat shutoff. (Item No.11) Cut the 2 wires leaving enough to splice together to close the circuit. (NOTE: Don't worry there are new thermostat shutoffs on the new heater assembly.)
7. Remove the heater assembly from the unit. (Item No.8)
8. Remove the replacement heater assembly from the carton.
9. Assemble the heater cover (Item No.6) to the heater assembly (Item No.8) with the (4) wing nuts. (NOTE: The position of the threaded studs is up.)
10. Check the position of the screen. (Item No.5) Make sure the clearance holes line up with the holes located around the vent opening.
11. Position the heater assembly such that the heater cover is facing out away and thermostats are in back. Line up the heater assembly with the holes around the unit vent.
12. Position the wire mesh cover (Item No.4) over the opening and secure with the (6) torx screws (Item No.3).
13. Position the blower assembly (Item No.9) over the heater assembly (Item No.8). Secure with the (8) wing nuts to the heater assembly and the (2) ¼" hex head screws into the panel.
14. Reinsert the new twist lock plug (Item No.13) from the heater assembly to the (2) 20 amp receptacles.
15. Reinsert the twist lock plug (Item No.12) from the blower assembly (Item No.9) to the 15-amp receptacle.
16. Make sure all plugs are securely in place. Twist to lock in place.
17. Replace the outside cover (Item No.1) with (12) torx screws.
18. Turn power on, and follow the operating instructions.

If you need further assistance, call Ready Access Inc service representative at 800-621-5045.

NOTES



Ready Access, 1815 Arthur Drive, West Chicago, Illinois 60185, Tel: 630-876-7766, Tel: 800-621-5045
Fax: 630-876-7767, Email: ready@ready-access.com, Website: www.ready-access.com