

Item no.	Part no	Reference	Description
1		►1	Control panel
2		►2	Electrical installation
3		►3	Clima Plus
4		►4	Steam generator, Bypass
5		►5	Hot air heating
6		►6	Motor and fan wheel
7		►7	Interior cabinet
8		►8	Door
9		►9	Water supply, quenching box
10		►10	Hand shower
12		►12	Gas parts
13		►13	Exterior cabinet
14		►14	Miscellaneous

1	Control panel	3
1.A	Control panel.....	4
2	Electrical installation	5
2.A	Contactor assembly UL.....	6
3	Clima Plus.....	7
4	Steam generator, Bypass	8
4.A	Pump connection spout cpl.	10
4.B	Venting valve for steam generator	11
5	Hot air heating	12
5.A	Burner hot air	13
6	Motor and fan wheel	14
7	Interior cabinet	15
7.A	Interior cabinet welded	16
7.B	Gasket frame w. glass a. gaskets	17
7.C	Air baffle.....	18
7.C	Air baffle.....	19
8	Door	20
8.A	Door	22
8.C	Door catch.....	23
9	Water supply, quenching box.....	24
10	Hand shower.....	25
12	Gas parts	26
12.A	Gas valve cpl. ND 055 RG148	28
12.B	Gas valve cpl. WND 055 RG130.....	29
13	Exterior cabinet.....	30
13.A	Exterior cabinet	31
14	Miscellaneous	32

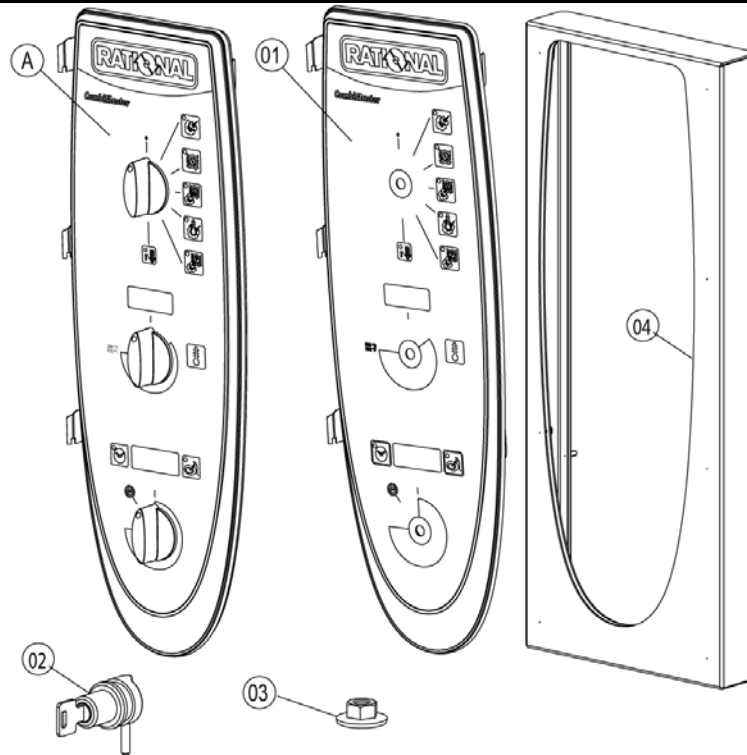

Item no.	Part no	Reference	Description
A		►1.A	Control panel
1	87.00.003		Control panel insert with overlay

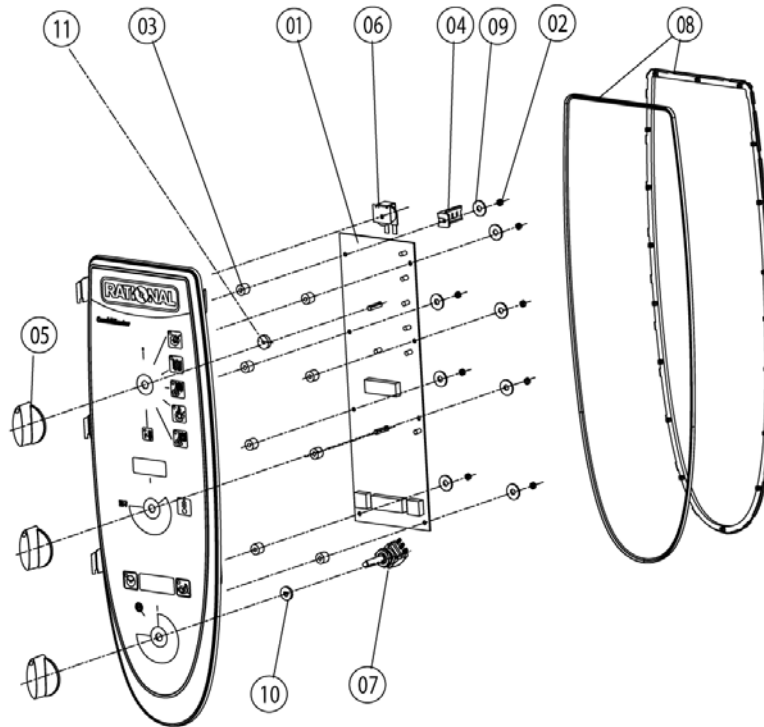

Item no.	Part no	Reference	Description
1	42.00.047		Control pcb Index "MF"
2	1103.0122		Hex nut M3 self-locking
2	1104.0121		Hex nut M4 self locking
3	10.00.355		Spacer black
4	2020.0400		Fixing device for cable harness
5	16.00.282		Dial
6	40.02.087		Buzzer
7	40.00.464		Potentiometer CT
8	16.00.387		Mounting device f.sealing + sealing lip
9	1306.0218		Washer A4,3
10	5110.1029		Gasket mode switch
11	5110.1027		Distance plate for front panel

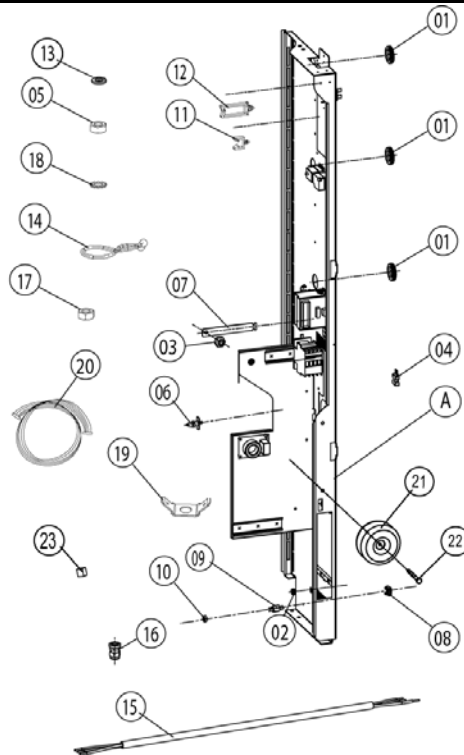

Item no.	Part no	Reference	Description
A		►2.A	Contacteur assembly UL
1	4007.0620		Membrane DGC 29
2	10.00.510		Grommet 10/12/16-2
3	1106.0224		Hex nut M6 self locking
4	42.00.007		External memory
6	40.01.579		Fixing clip f. pcb
7	40.01.132		Center fixation f. contactor assembly
8	1104.0801		Cage nut M4
9	10.00.243		Spacer M4x8
10	1104.0120		Hex nut M4
11	10.00.112		Cable clip short
12	10.00.111		Cable clip long
14	10.00.471		Cable clip d10-12mm
15	40.01.597		Power supply cable 3xAWG14
16	40.00.320		Cable connection M20x1.5
17	1106.0160		Hex nut M6
18	1206.0120		Tooth lock washer A6,4
19	4002.0110		Cable connector, junction
20	40.01.091		Bus cable 0.4m
20	40.00.471		Bus cable 0.8m
21	40.00.281		Power transformer
22	10.00.445		Hex screw M8x80
23	40.01.600		Insulating screw joint 2pol.

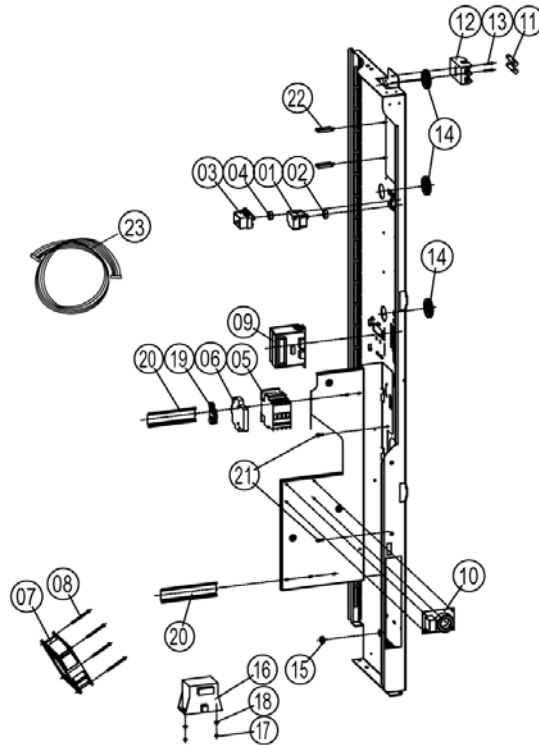

Item no.	Part no	Reference	Description
1	3014.0328		Dry up protector 275°F/135°C
2	3014.0302		Hex nut M10 for dry-up protector
3	40.01.482		Safety temperature limiter 365°C
4	3014.0327		Hex nut M10x1,0
5	40.00.451		Contacteur MC1A 310 AH6
7	40.00.474		Cooling fan D.C.
8	10.00.238		Screw Torx 4x50
9	40.00.277		Control transformer
10	40.01.483		Electronic noise filter
12	40.01.487		Fuse holder 2pol
13	10.00.364		Pan head screw Torx M3x12
14	4007.0620		Membrane DGC 29
15	10.00.510		Grommet 10/12/16-2
16	40.00.592		Transformer f. cooling fan
17	1105.0120		Hex nut M5
18	1305.0160		Washer A5,3x10mm
19	4001.1203		End plate for mounting rail
20	2620.370233		Installation rail for Contactor 100mm
20	2816.1307		Installation rail for Contactor 140mm
21	10.00.061		Pan head screw Torx T20 M4x12
22	10.00.111		Cable clip long
23	40.01.485		Cable burner blower
23	40.00.221		Cable burner blower
23	40.00.218		Cable control harness
23	40.00.230		Cable gas valve
23	40.00.249		Cable harness isolating transformer
23	40.01.542		Cable level electrode
23	40.00.219		Cable SC pump
23	40.00.220		Cable solenoid valve
23	40.00.237		Ground wire

Attention! Individual parts shown might not be used in this component group!

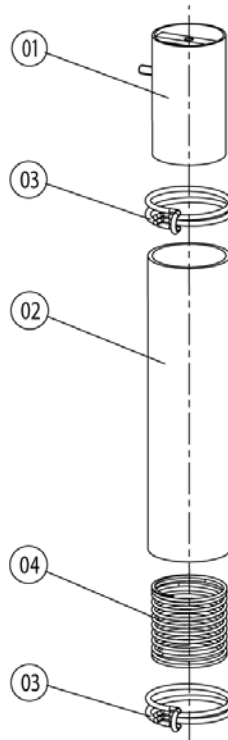

Item no.	Part no	Reference	Description
1	22.00.324		Safety valve
2	22.00.214		Hose d50x202
3	2066.0531		Hose clamp ø56
4	2001.0124		Compression spring

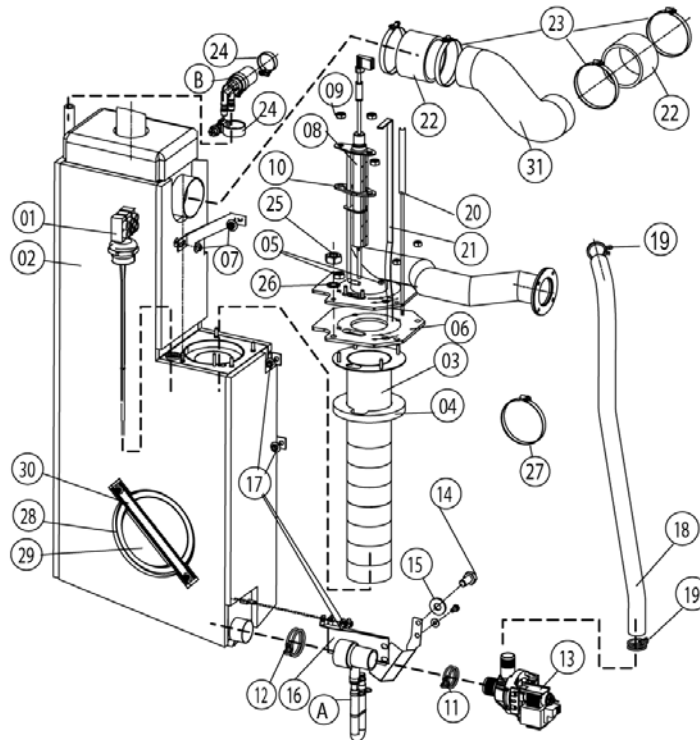

Item no.	Part no	Reference	Description
A	8354.1320	►4.A	Pump connection spout cpl.
B	8354.1304	►4.B	Venting valve for steam generator
1	44.00.287		Filling level electrode 135mm
2	44.00.187		Steam generator insolated
3	72.00.011		Burner steam gen.
4	72.00.048		Insulation f. burner steam gen.
5	1104.0122		Hex combination nut M4 galv
6	72.00.020		Gasket f. burner carrier
7	1105.0121		Hex combination nut M5 galv
8	44.00.249		Ignition electrode steam generator
9	1104.0120		Hex nut M4
10	44.00.250		Gasket f. ignition electrode
11	2066.0519		Hose clamp 35,6mm
12	2066.0526		Hose clamp ø46mm
13	44.00.207		Emptying pump
14	1006.0762		Hex screw M6x10
15	1306.0222		Washer A6,4x15x1,5
16	44.00.226		Fixing device f. pump steam generator
17	1106.0803		Hex combination nut M6 galv
18	44.00.238		Drain hose steam generator
19	2066.0518		Hose clamp 30mm
20	40.01.095		Thermocouple steam gen. (B5)
20	40.00.291		Thermocouple steam generator
21	44.00.517		Fixing plate steam generator thermostat
22	44.00.362		Steam hose 70x5
23	2066.0505		Hose clamp 70-90mm
24	2066.0506		Hose clamp 20-32mm
25	1105.0120		Hex nut M5
26	1205.0120		Tooth lock washer A5,3
27	2066.0300		Hose clamp 50-70 mm



CM 202G

Valid as of G22MF0602 up to G22MF....

Gas unit

▶ 4 Steam generator, Bypass

4

4 Steam generator, Bypass Voltage 1 NAC 120V 60Hz

Item no.	Part no	Reference	Description
28	5012.0566		Gasket quenching chamber O-ring
29	44.00.263		Panel for revision hole steam generator
30	44.00.264		Clamping bar for panel revision hole
31	44.00.361		Steam pipe

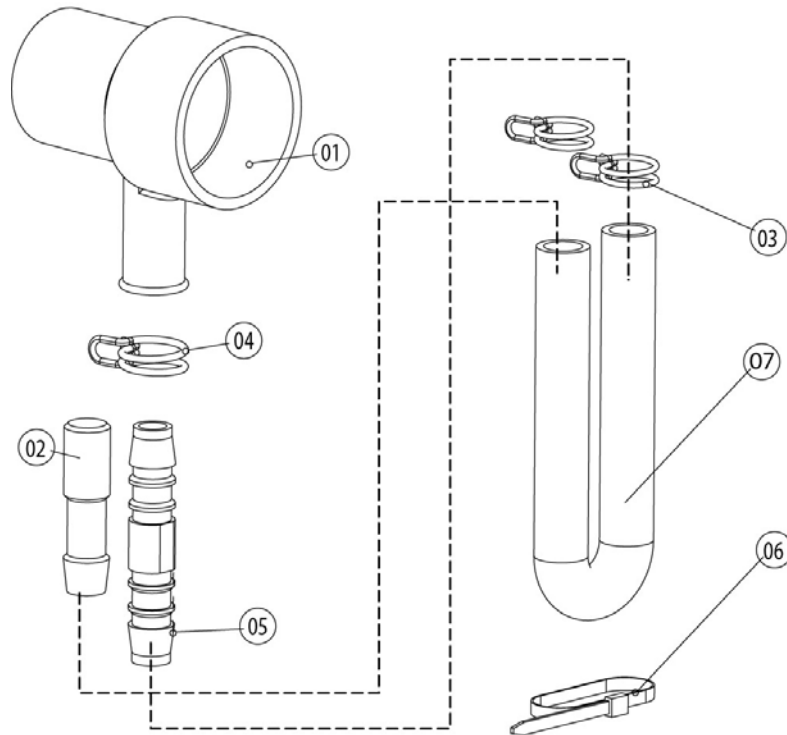

Item no.	Part no	Reference	Description
1	2118.1000		Pump connection spout
2	2120.1259		Stop plug 10mm
3	2066.0527		Hose clamp ø14mm
4	2066.0530		Hose clamp ø16.4mm
5	2062.0331		Junction pressure hose GS 10
6	4005.0101		Tie rap 145 mm

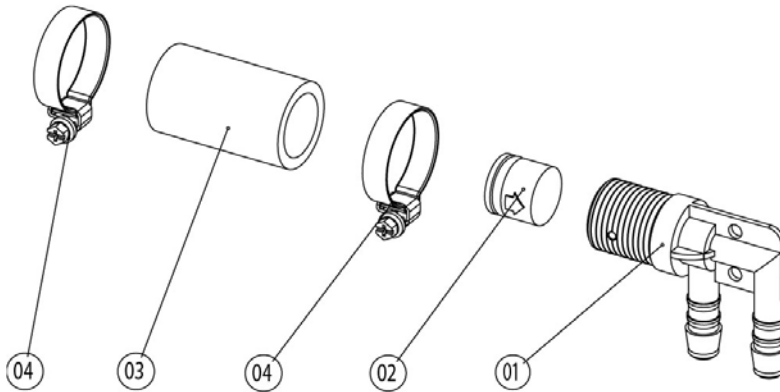

Item no.	Part no	Reference	Description
1	2062.0332		Receptacle for ventilation valve SG
2	2069.0108		Ventilation valve
3	2112.1310		Form hose for ventilation of steam generator
4	2066.0506		Hose clamp 20-32mm

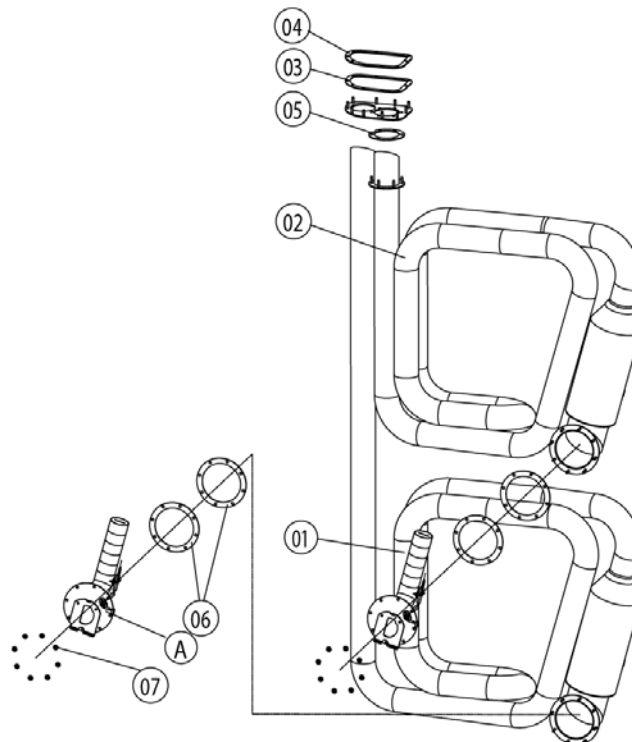

Item no.	Part no	Reference	Description
A	74.00.243	►5.A	Burner hot air
1	74.00.180		Hot air heat exchanger below
2	74.00.183		Hot air heat exchanger top
3	74.00.234		Gasket hot air heat exchanger/interior cabinet
4	74.00.313		Mating flange heat exchanger
5	74.00.318		Gasket f. heat exchanger top
6	74.00.296		Gasket f. heat exchanger below
7	1105.0122		Hex combination nut M5 V2A

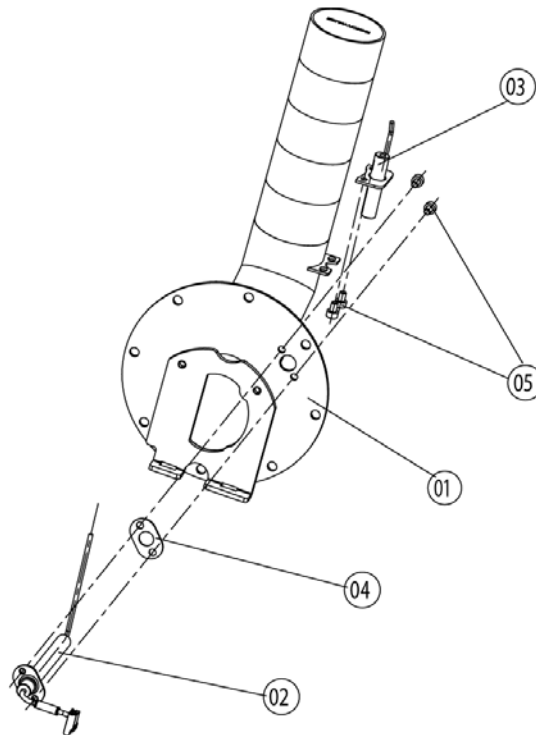

Item no.	Part no	Reference	Description
1	74.00.343		Burner welded hot air
2	74.00.230		Ignitionelectrode1 f. hot air
3	74.00.235		Ignitionelectrode2 f. hot air
4	74.00.290		Gasket electrode hot air
5	10.00.696		Allen screw M4x6 w. Precoat 85
5	10.00.060		Pan head screw Torx M4x6

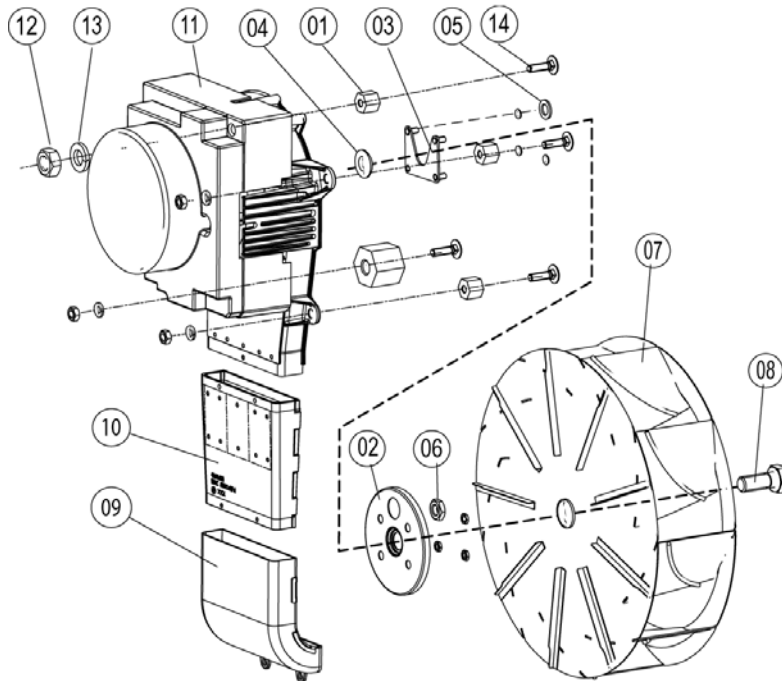

Item no.	Part no	Reference	Description
1	2120.1306		Spacer SW19x17
2	22.00.123		Flange f. motor shaft gasket
3	22.00.120		Mounting support f. gasket flange
4	22.00.083		Motor shaft gasket
5	1315.0101		Copper washer 6x10
6	1106.0220		Hex nut M6 flat
7	22.00.192		Fan weel d340x135
8	1008.0763		Hex screw M8x20
8	10.00.565		Hex screw M8x20
11	40.00.274		Fan motor
12	1108.0260		Hex nut M8
12	10.00.071		Hex nut M8
12	10.00.710		Hex nut M8 w. locking
13	1208.0260		Spring washer B8
14	1008.1005		Square necked mushroom head bolt 8x40

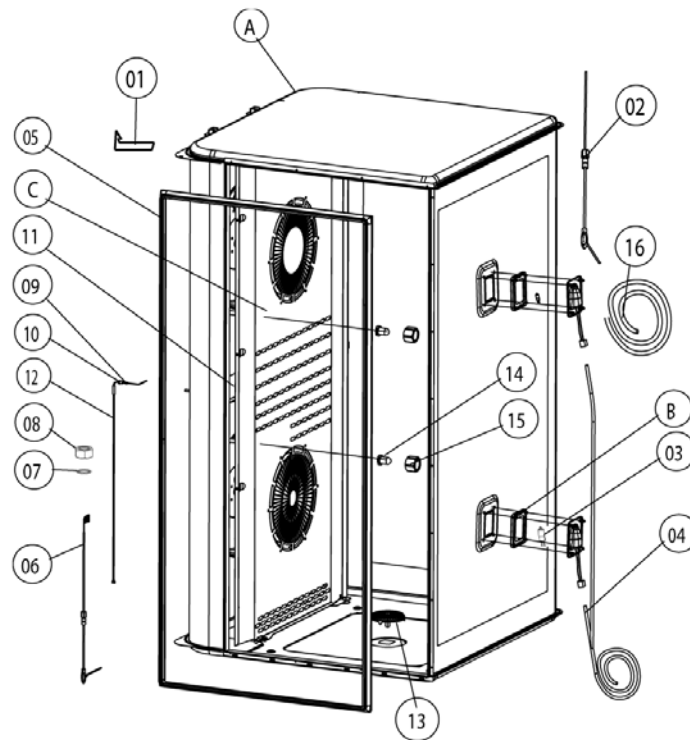

Item no.	Part no	Reference	Description
A		►7.A	Interior cabinet welded
B	40.00.091	►7.B	Gasket frame w. glass a. gaskets
C	22.00.299	►7.C	Air baffle
C	22.00.298	►7.C	Air baffle
3	3024.0201		Halogen bulb for interior cabinet 300°C
4	40.00.229		Wiring interior light
5	20.00.399		Door gasket
6	40.00.298		Meat probe sensor
6	40.01.943		Meat probe sensor
6	40.02.103		Meat probe sensor
7	1315.0104		Copper washer 16x20x1,5
8	10.00.422		Hex nut M16
9	3014.0162		Sealing cone for thermocouple
10	3014.0163		Gasket sleeve with nipple
11	22.00.429		Air baffle support
11	22.00.222		Air baffle support
12	40.01.099		Thermocouple interior cabinet (B1)
13	2005.0308		Outlet sieve

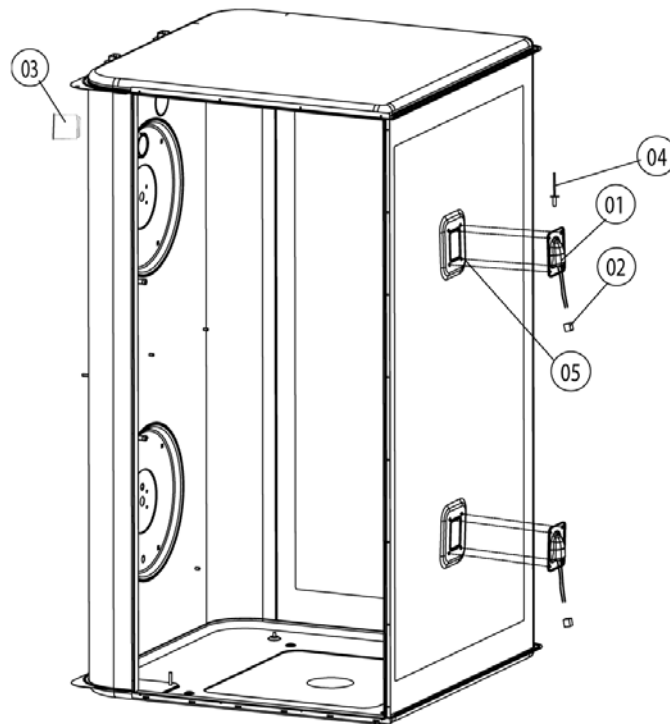

Item no.	Part no	Reference	Description
1	40.00.098		Reflector f. interior light
2	4001.1248		Porcelain connector 2-pin interior light
3	2120.1277		Base for sensor connection
4	1603.0167		Tubular rivet 3,2x0.25x10
5	10.00.041		Rivet nut M5 hexagon closed

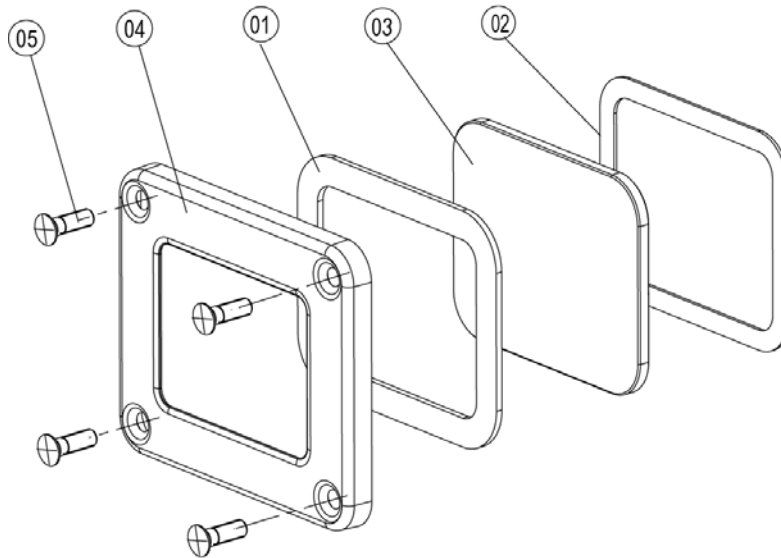

Item no.	Part no	Reference	Description
1	40.00.093		Outer gasket f. interior light
2	40.00.094		Inner gasket f. interior light
3	40.00.095		Glass pane f. interior light
4	40.00.096		Gasket frame f. interior light
5	10.00.682		Phillips countersunk-head screw M5x16

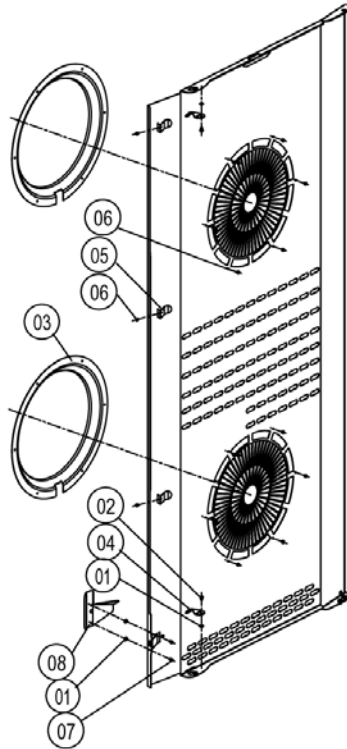

Item no.	Part no	Reference	Description
1	1304.0160		Washer A4,3
2	1604.0167		Rivet 4x10
3	22.00.332		Air sucking ring f. air baffle
4	2760.1370		Latch hook for air baffle
5	40.01.289		Fixing clip core temp. cable
6	10.00.515		Rivet 3,2x5 A4
7	1603.0168		Rivet 3,2x8 A4
8	22.00.440		Guard plate f. core sensor

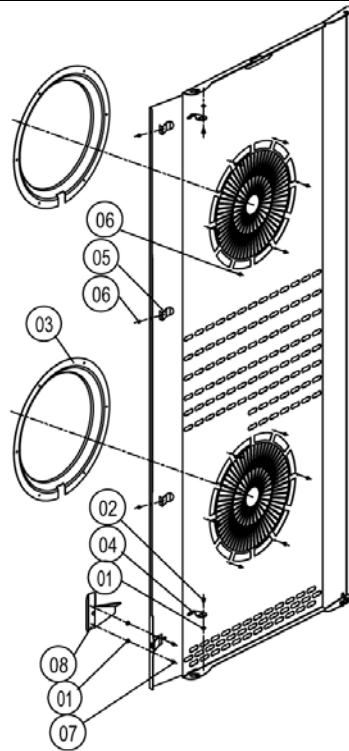

Item no.	Part no	Reference	Description
1	1304.0160		Washer A4,3
2	1604.0167		Rivet 4x10
3	22.00.332		Air sucking ring f. air baffle
4	2760.1370		Latch hook for air baffle
5	40.01.289		Fixing clip core temp. cable
6	10.00.515		Rivet 3,2x5 A4
6	1603.0166		Rivet 3,2x7,9 CNS closed
7	1603.0168		Rivet 3,2x8 A4
8	22.00.440		Guard plate f. core sensor

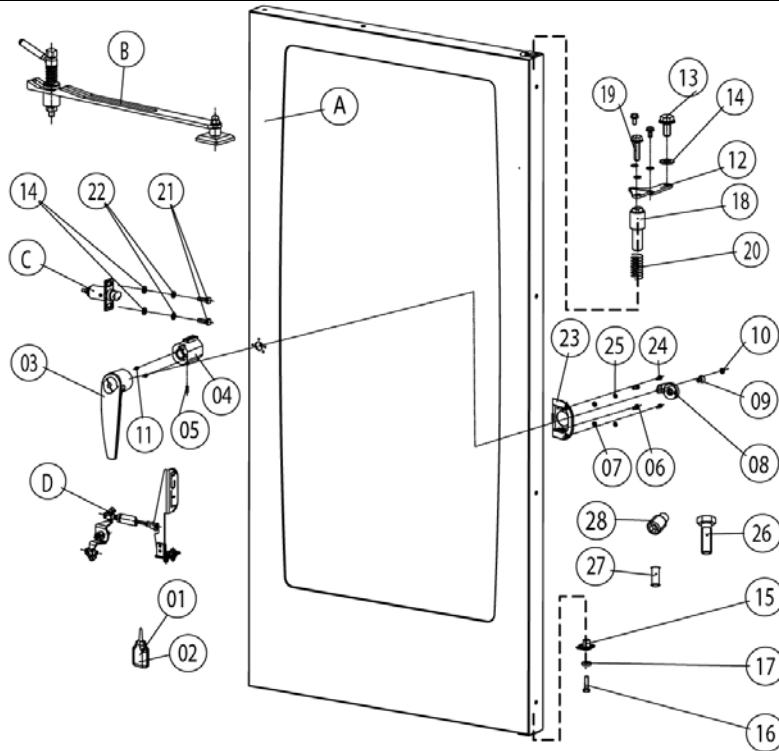

Item no.	Part no	Reference	Description
A	24.00.126	▶8.A	Door
C	8514.1307	▶8.C	Door catch
1	2001.0042		Loctite 243 10 ml
2	2001.0046		Loctite 272
3	24.00.136		Door handle
4	8474.1410		Door lock
5	1005.1901		Straight pin ø5,6x16
6	1006.0761		Hex screw M6x12
6	10.00.698		Hex screw M6x12 w. precoat 85
7	1206.0261		Spring washer B6
8	2940.1305		Door bolt
9	1008.1963		Hex socket countersunk head screw M8x16
10	2039.0309		Cover cap for door
11	1004.0665		Allen screw M4x6
11	10.00.696		Allen screw M4x6 w. Precoat 85
12	24.00.133		Door mounting support top
13	1008.0768		Ornamental screw M8x16
14	1308.0160		Washer A8,4
15	24.00.145		Door bolt
16	1008.0766		Hex screw M8x30
17	1308.0162		Washer A8,4
18	24.00.048		Door bolt
19	1008.0769		Ornamental screw M8x30
20	2001.0109		Compression spring
21	1008.0761		Hex screw M8x25
22	1208.0260		Spring washer B8
23	24.00.216		Mounting bracket f. door lock
24	1008.0752		Hex screw M5x10
24	10.00.697		Hex screw M5x10 w. precoat 85
25	1305.0160		Washer A5,3x10mm



CM 202G

Valid as of G22MF0602 up to G22MF....

Gas unit

▶ 8 Door

8

8 Door

Voltage 1 NAC 120V 60Hz

Item no.	Part no	Reference	Description
26	10.00.099		Hex screw M8x12
27	1005.1903		Straight pin ø5,6x12
28	1004.0906		Hex socket set screw M4x8

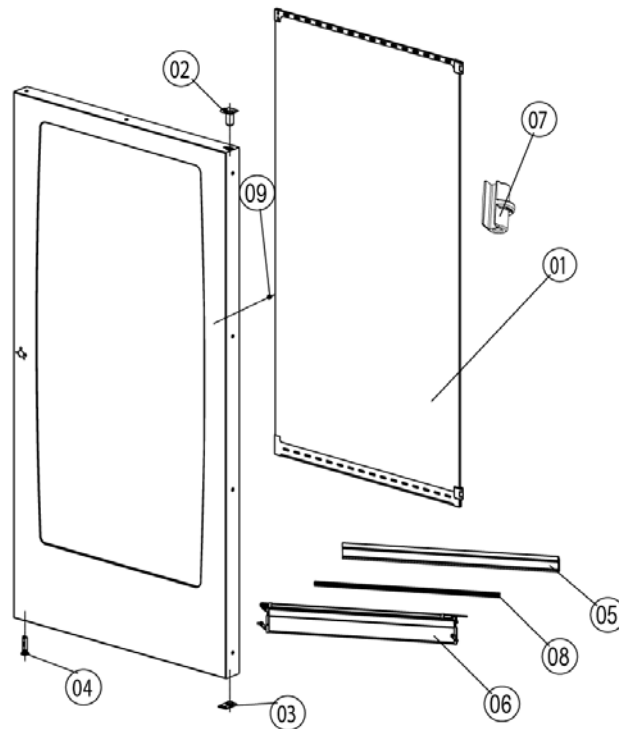

Item no.	Part no	Reference	Description
1	24.00.212		Inner glass pane
2	24.00.147		Sleeve for door bolt top
3	24.00.159		Door setting bolt
4	24.00.503		Fixing device f. magnet with magnet
5	24.00.194		Gasket glass pane/trolley
6	24.00.178		Pre heat mechanism f. door cpl.
7	24.00.507		Fixing device middle f.inter. glass pane
8	24.00.701		Additional gasket f. trolley
9	24.01.259		Plastic buffer 8,1mm

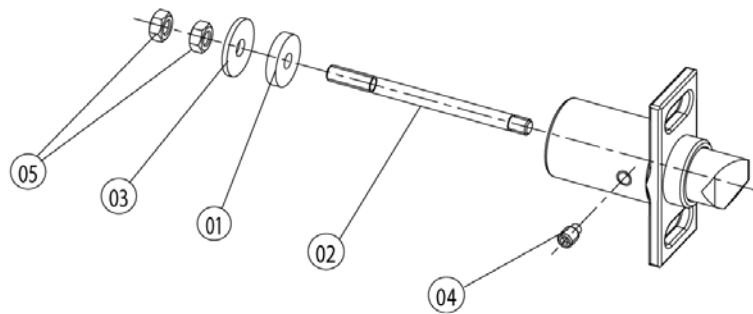

Item no.	Part no	Reference	Description
1	5012.0711		Silicone plate for door
2	1006.1000		Stud bolt M6x75
3	1306.0550		Washer A6,6
4	1004.0904		Hex socket set screw M6x10
5	1106.0160		Hex nut M6
6	2001.0119		Compression spring f. door catch
7	1006.0625		Allen screw M6x70

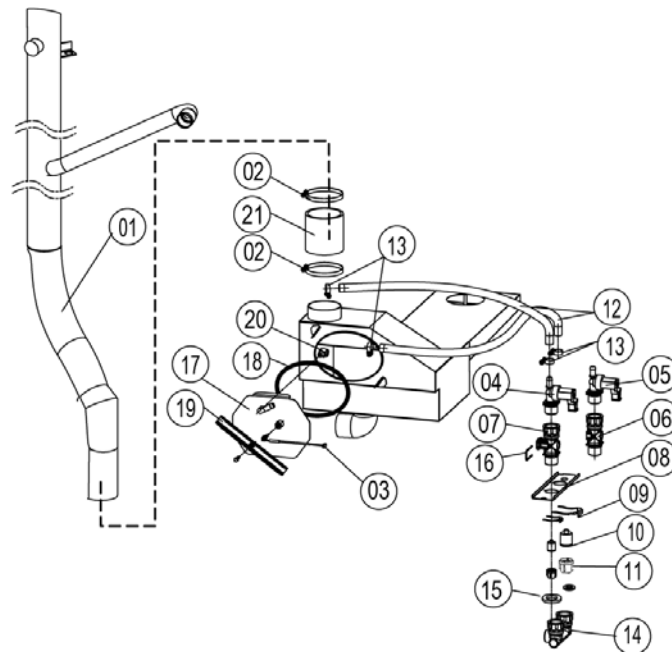

Item no.	Part no	Reference	Description
1	54.00.210		Exhaust pipe
2	2066.0516		Hose clamp 60-80 mm
3	40.00.398		Thermocouple quenching
4	50.00.316		Single solenoid valve
5	50.00.139		Single solenoid valve
6	50.00.073		Water distribution vert w/o roll guide con.
7	50.00.072		Water distribution vert roll guide con.
8	50.00.277		Mounting device f. water distribution
9	50.00.086		Locking plate f. water distribution
10	50.00.078		Non return valve DW16/DN12
11	1900.0202		Water filter
12	2067.0050		Pressure hose d10mm
13	2066.0205		Hose clamp 8-16x9 mm SW 7mm
14	8664.1301		T-fitting water connection
15	5110.1024		Gasket for G3/4" threaded joint
16	50.00.085		Plug-in spring f. hand shower roll guide
17	54.00.237		Inspection lid f. quenching chamber
19	54.00.225		Clamping bar
20	2016.0943		Quenching nozzle
21	2112.1307		Hose 70x5mm

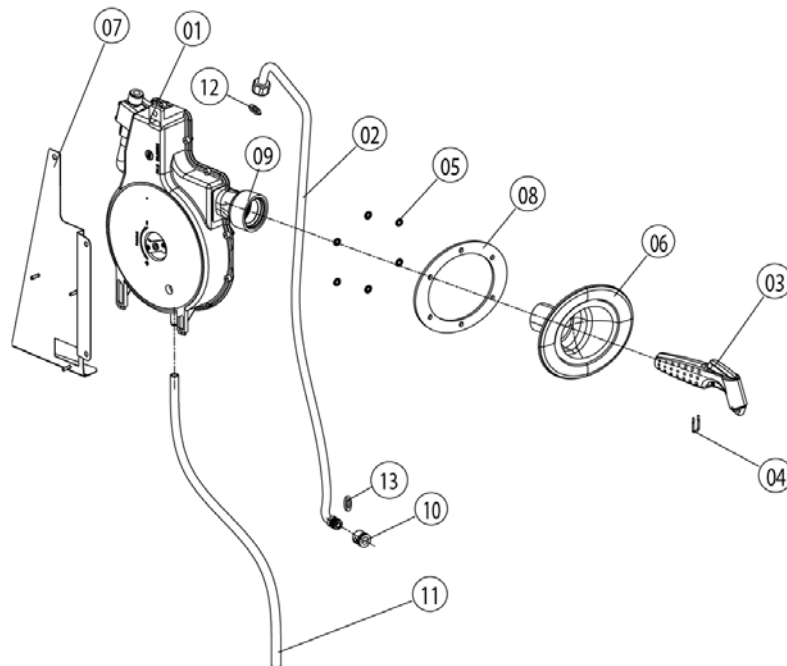

Item no.	Part no	Reference	Description
1	50.00.176		Hand shower roll guide
2	50.00.230		Connect. pipe f. hand shower roll guide
3	50.00.130		Hand shower
4	50.00.156		Clamp f. hand shower roll guide
5	1107.0100		Star lock $\varnothing 4$
6	50.00.135		Tulip for handshower
7	50.00.544		Mounting device f. hand sh. roll guide
8	50.00.290		Gasket f. tulip
9	50.00.297		Gasket f. tulip
11	50.00.548		Hose $\varnothing 10 \times 2 \times 500$ f. hand shower
12	50.00.537		Gasket f. connect.pipe hand shower roll guide
13	50.00.538		O-ring f. connect. pipe f. hand shower roll guide

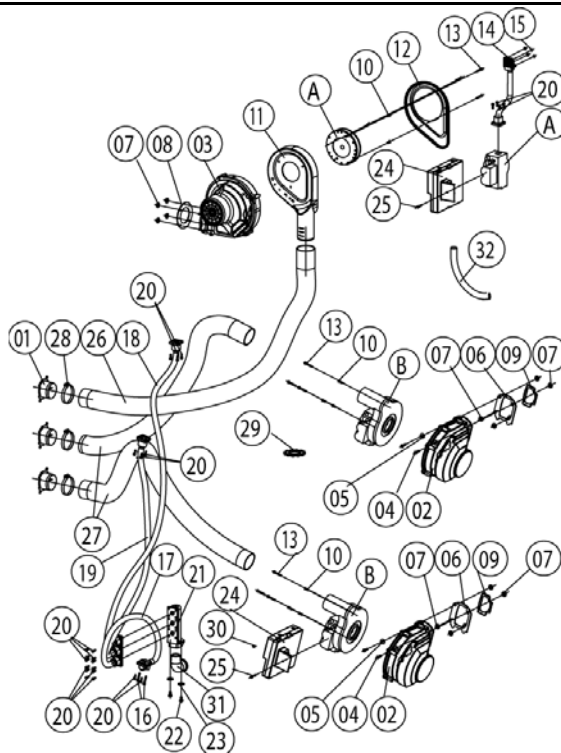

Item no.	Part no	Reference	Description
A	70.00.068	►12.A	Gas valve cpl. ND 055 RG148
B	70.00.029	►12.B	Gas valve cpl. WND 055 RG130
1	70.00.222		Air hose fixing device 50mm
2	70.00.028		Blower for burner RG130
3	70.00.067		Blower for burner RG148
4	1008.0750		Hex screw M5x16
5	1305.0160		Washer A5,3x10mm
6	74.00.310		Flange f. burner blower RG130
7	1105.0122		Hex combination nut M5 V2A
8	70.00.242		Gasket f. steam gen blower RG148
9	74.00.301		Gasket f. blower burner
10	10.00.065		Countersunk screw Torx T20 M4x12
11	70.00.239		Premix chamber gas f. RG148
12	70.00.238		Premix chamber cover gas f. RG148
13	10.00.063		Pan head screw Torx T20 M4x25
14	70.00.246		Pipe gas valve-premix chamber
15	1104.0121		Hex nut M4 self locking
16	10.00.064		Pan head screw Torx T20 M4x30
17	70.00.152		Corrugated hose 160mm
18	70.00.149		Corrugated hose 1100mm
19	70.00.196		Corrugated hose 780mm
20	10.00.061		Pan head screw Torx T20 M4x12
21	74.00.309		Gas connection manifold 3x3/4"
22	1006.0762		Hex screw M6x10
23	1306.0222		Washer A6,4x15x1,5
24	74.00.221		Automatic ignition controller
25	10.00.062		Pan head screw Torx T20 M4x20
26	70.00.147		Air hose D50x1550mm
27	70.00.135		Air hose D50x1100mm
28	2066.0504		Hose clamp 40-60mm



CM 202G

Valid as of G22MF0602 up to G22MF....

Gas unit

▶ 12 Gas parts

12

12 Gas parts

Voltage 1 NAC 120V 60Hz

Item no.	Part no	Reference	Description
29	1204.0120		Tooth lock washer A4,3
30	40.01.581		Jumper
31	70.00.188		Hose fitting 3/4"-3/4"
32	70.00.280		Silicone hose ø4x1,5

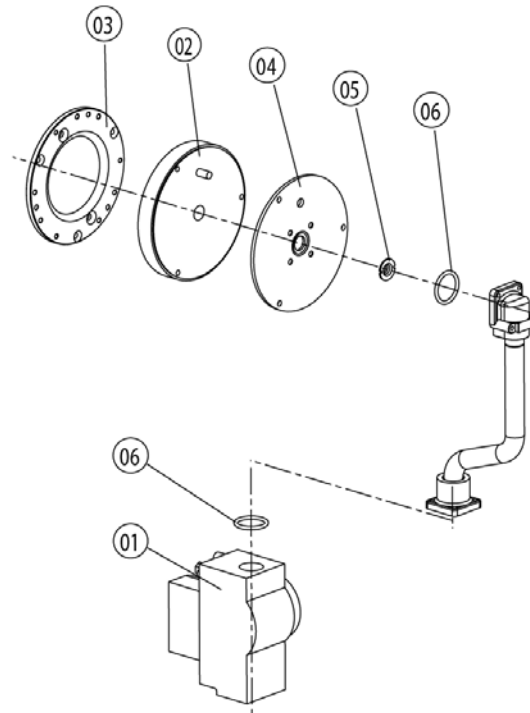

Item no.	Part no	Reference	Description
1	70.00.220		Gas valve GB 055 ND (straight)
2	70.00.106		Premix disc gas
3	70.00.208		Disc premix chamber-blower RG148
4	70.00.108		Disc gas valve-premix chamber
5	70.00.260		Gas nozzle 7mm
6	70.00.261		O-ring 17x1.5

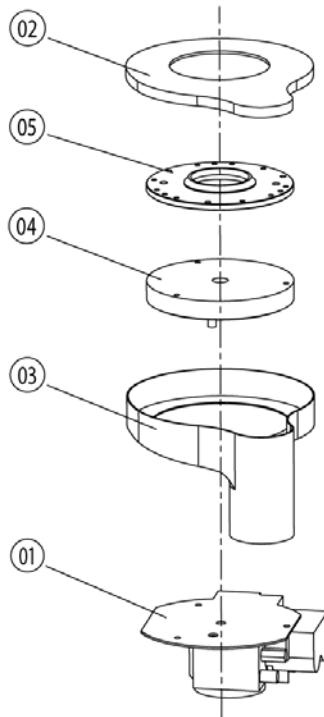

Item no.	Part no	Reference	Description
1	70.00.031		Gas valve GB 055 WND (lateral)
2	70.00.255		Premix chamber cover gas f. RG130
3	70.00.030		Premix chamber gas f. RG130
4	70.00.106		Premix disc gas
5	70.00.256		Disc premix chamber-blower RG130

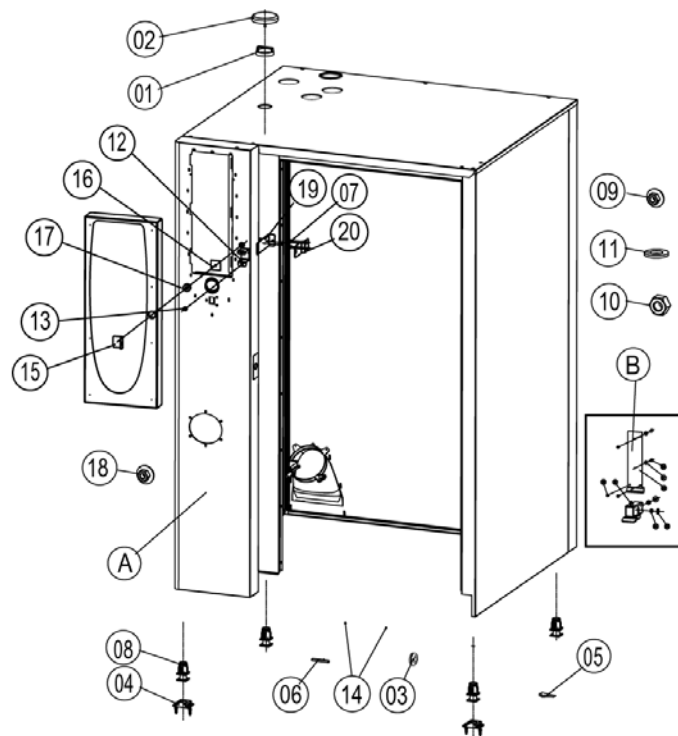

Item no.	Part no	Reference	Description
A		►13.A	Exterior cabinet
1	8450.1310		Spacer ring
1	22.00.354		Spacer ring
2	8455.1209		Vent cover
2	22.00.353		Vent cover
3	2022.0101		Grommet 18 mm
4	8700.0317		Floor fixing for units
5	5006.0213		Glue for floor fixing brackets
6	5013.0100		Edge protection profile
8	2039.0111		Foot adjustable, metal, 40 x 40

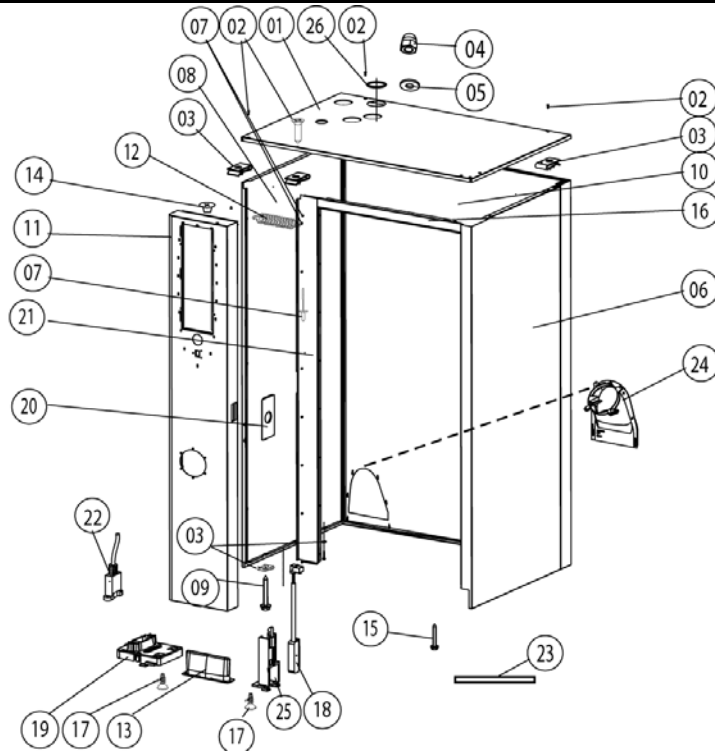

Item no.	Part no	Reference	Description
1	16.00.333		Top cover
2	1003.2265		Countersunk self tapping screw 4,2x16
3	1104.0820		Snap nut 4,2mm
4	1105.0260		Cap nut M5, high shape
5	1305.0160		Washer A5,3x10mm
6	16.00.158		Side panel right
7	1603.0166		Rivet 3,2x7,9 CNS closed
8	16.00.139		Side panel left
9	10.00.102		Hex self tapping screw B4,2x32
10	16.00.383		Back panel
11	16.00.296		Front panel
12	2002.0107		Tension spring for front panel
13	16.00.673		Air inlet filter
14	2039.0331		Cap for service door
15	1004.2160		Hex self tapping screw 4,2x16
16	16.00.331		Crossbar top
17	10.00.103		EJOT PT-screw KA 3.5x10
18	40.00.454		Door switch 1.65m
19	16.00.360		Cover f. RS232 interface
20	16.00.115		Rosette
21	16.00.358		Crossbar front panel
23	16.00.338		Edge protection profile
24	40.00.476		Exhaust channel
25	16.00.384		Bracket for door contact switch
26	5105.1028		Gasket f. breather tube d=74mm

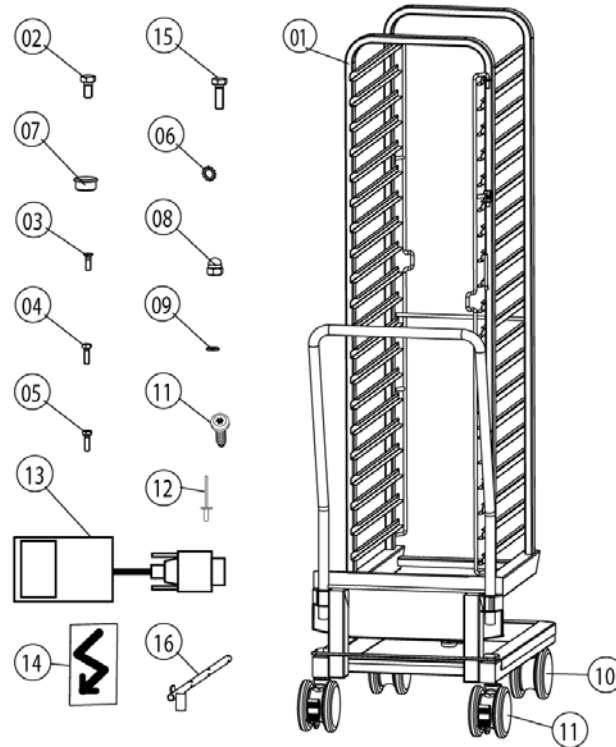

Item no.	Part no	Reference	Description
2	1008.0760		Hex screw M8x16
3	10.00.448		Phillips countersunk-head screw M5x16
4	1006.0760		Hex screw M6x16
6	1208.0160		Tooth lock washer A8,4
7	10.00.357		Rubber plug black
8	1106.0360		Cap nut M6, high shape
9	1306.0120		Washer A6,4
10	60.60.101		Castor without brake \varnothing 125mm
11	60.60.100		Castor with brake \varnothing 125mm
12	1603.0162		Rivet 3,2x9
13	42.00.030		Memory-Stick
14	4019.0008		Sticker Electric/Danger
16	60.60.574		Positioning support f. core sensor