



CM 61E

Valid as of E61ME0404 up to
E61ME0601

Electrical unit

► CM 61E

Voltage 3 AC 200V 50-60Hz

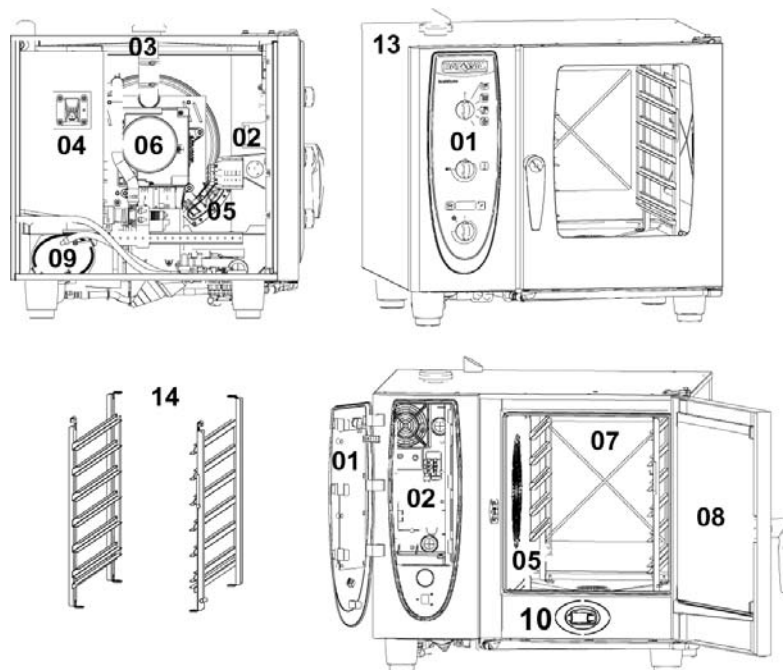

Item no.	Part no	Reference	Description
1		►1	Control panel
2		►2	Electrical installation
3		►3	Clima Plus
4		►4	Steam generator, Bypass
5		►5	Hot air heating
6		►6	Motor and fan wheel
7		►7	Interior cabinet
8		►8	Door
9		►9	Water supply, quenching box
13		►13	Exterior cabinet
14		►14	Miscellaneous

1	Control panel	3
1.A	Control panel.....	4
2	Electrical installation	5
2.A	Contact assembly	6
2.B	Cable entry.....	7
3	Clima Plus.....	8
4	Steam generator, Bypass	9
4.A	Pump connection spout cpl.	10
4.B	Venting valve for steam generator	11
5	Hot air heating	12
6	Motor and fan wheel	13
7	Interior cabinet	14
7.A	Interior cabinet	15
7.B	Gasket frame w. glass a. gaskets	16
7.C	Air baffle.....	17
8	Door	18
8.A	Door	19
9	Water supply, quenching box.....	20
13	Exterior cabinet	21
13.A	Exterior cabinet	22
14	Miscellaneous	23

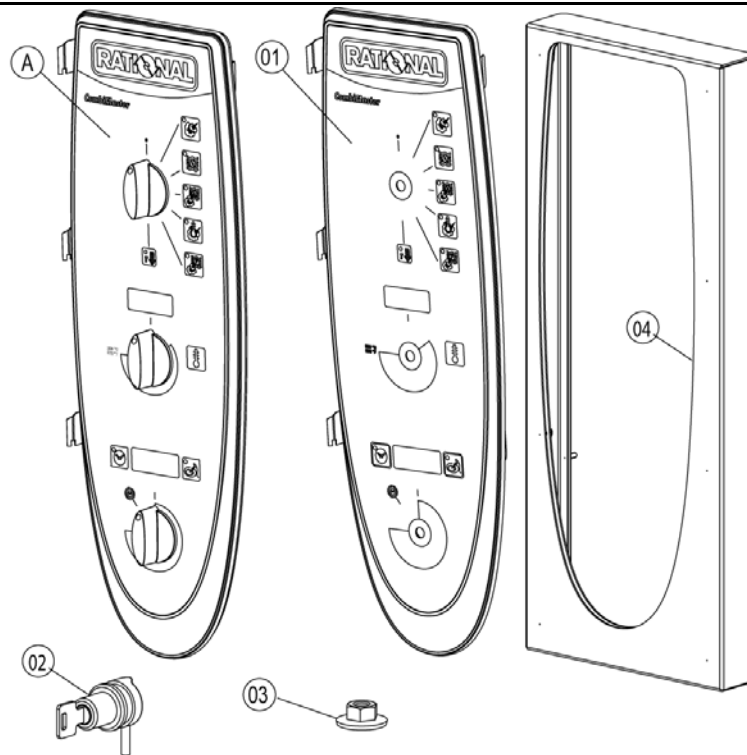

Item no.	Part no	Reference	Description
A		►1.A	Control panel
1	87.00.001		Control panel insert with overlay

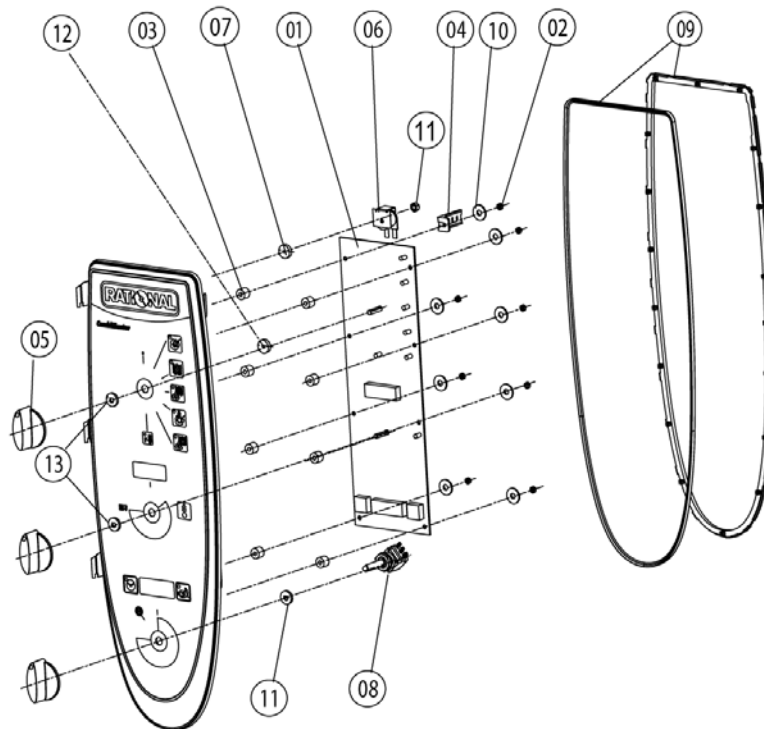

Item no.	Part no	Reference	Description
1	42.00.004		Control pcb Index "ME"
2	1104.0121		Hex nut M4 self locking
3	10.00.355		Spacer black
4	2020.0400		Fixing device for cable harness
5	16.00.282		Dial
6	40.02.087		Buzzer
6	3006.0107		Buzzer
7	5110.1028		Gasket poti hot air, core temperature
8	40.00.464		Potentiometer CT
9	16.00.387		Mounting device f.sealing + sealing lip
10	1306.0218		Washer A4,3
11	1103.0122		Hex nut M3 self-locking
12	5110.1029		Gasket mode switch
13	5110.1027		Distance plate for front panel

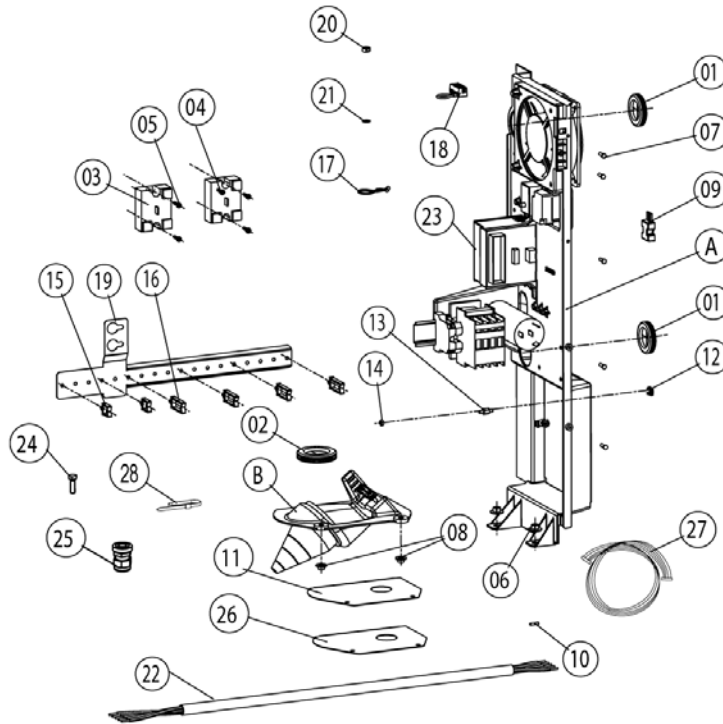

Item no.	Part no	Reference	Description
A		►2.A	Contacteur assembly
B	40.00.306	►2.B	Cable entry
1	4007.0620		Membrane DGC 29
2	4007.0621		Membrane DGC 36
3	40.01.589		Solid state relais
4	10.00.507		Pan head screw Torx 5/16" T20
5	10.00.444		Raised countersunk head screw Torx M4x8
6	1106.0803		Hex combination nut M6 galv
7	10.00.239		EJOT PT-Screw Torx 4x10
8	1105.0121		Hex combination nut M5 galv
9	42.00.007		External memory
12	1104.0801		Cage nut M4
13	10.00.243		Spacer M4x8
14	1104.0120		Hex nut M4
15	10.00.112		Cable clip short
16	10.00.111		Cable clip long
17	10.00.471		Cable clip d10-12mm
18	40.00.338		Sicotronic-terminal *screw typ*
19	40.01.090		Fixing device f. cable guide
20	1106.0160		Hex nut M6
21	1206.0120		Tooth lock washer A6,4
22	40.01.067		Power supply cable 4x4mm ²
27	40.00.471		Bus cable 0.8m
27	40.00.472		Bus cable 1.3m
28	10.00.414		Cable strap black 120°

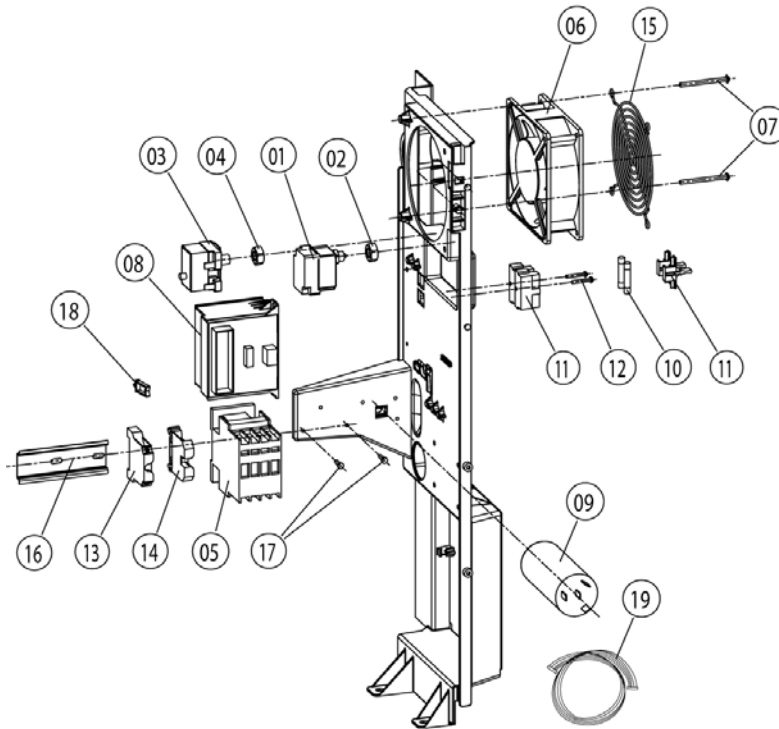

Item no.	Part no	Reference	Description
1	40.01.329		Dry up protector 160°
2	3014.0302		Hex nut M10 for dry-up protector
3	40.01.482		Safety temperature limiter 365°C
4	3014.0327		Hex nut M10x1,0
5	40.00.805		Contactor CL 25
6	3101.1008		Cooling fan
7	10.00.238		Screw Torx 4x50
8	40.00.278		Halogen transformer
9	10.00.239		EJOT PT-Screw Torx 4x10
10	4001.0224		Fuse 6.35x32mm
11	4001.1295		Fuse holder e 1003Si/1DS
12	10.00.240		Screw Torx 3x20
13	4001.1210		Earth terminal 16mm ² yellow/green
15	2005.0106		Protective grid for cooling fan
16	40.00.518		Installation rail for Contactor 95mm
17	40.00.465		Electronic noise filter
18	10.00.111		Cable clip long
19	40.00.212		Cable buzzer
19	40.00.232		Cable contactor-SSR
19	40.01.930		Cable contactor-SSR
19	40.01.279		Cable control harness
19	40.00.201		Cable control SSR
19	40.00.205		Cable level electrode
19	40.00.219		Cable SC pump
19	40.00.236		Cable solenoid valve

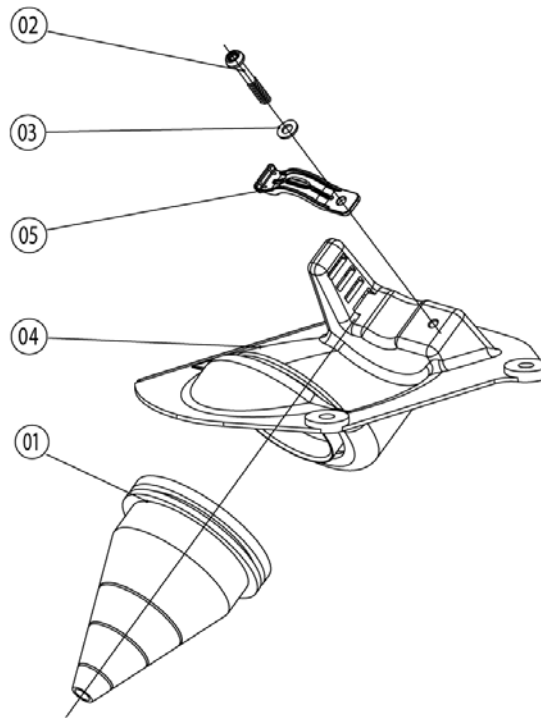

Item no.	Part no	Reference	Description
1	40.00.391		Cable bushing f. cable entry
2	10.00.115		Allen screw M5x30
3	1305.0160		Washer A5,3x10mm
4	40.00.307		Cable entry
5	40.00.312		Clamp strap f. cable entry

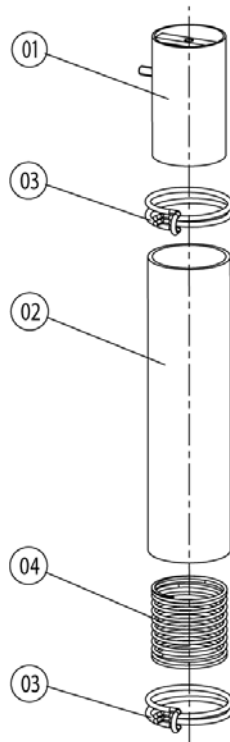

Item no.	Part no	Reference	Description
1	22.00.324		Safety valve
2	22.00.174		Hose d50x83
3	2066.0531		Hose clamp ø56

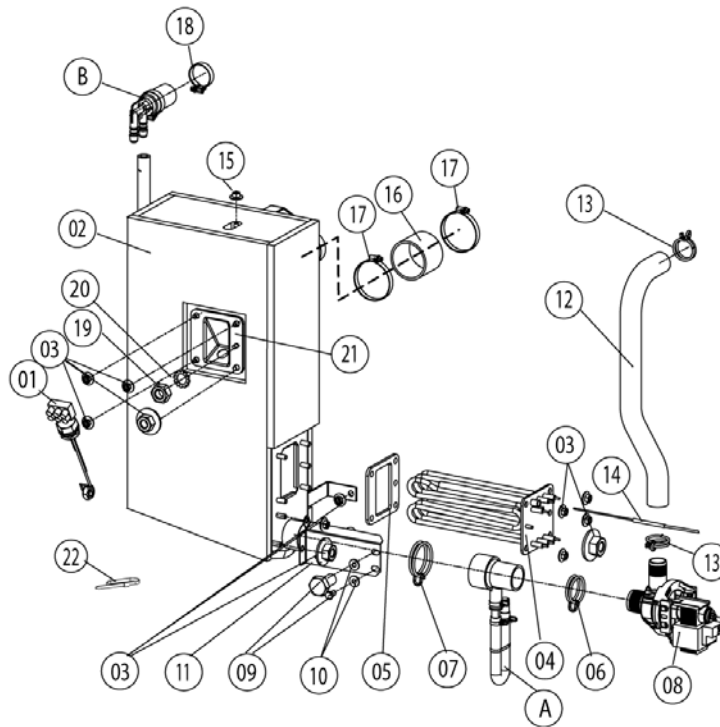

Item no.	Part no	Reference	Description
A	8354.1320	►4.A	Pump connection spout cpl.
B	8354.1304	►4.B	Venting valve for steam generator
1	3002.0402		Filling level electrode 90 mm
2	44.00.170		Steam generator insulated
3	1106.0803		Hex combination nut M6 galv
4	44.00.291		Heating element
5	44.00.280		Gasket f. heating element+Level elektrode insert
6	2066.0519		Hose clamp 35,6mm
7	2066.0526		Hose clamp \varnothing 46mm
8	44.00.207		Emptying pump
9	1006.0762		Hex screw M6x10
10	1306.0222		Washer A6,4x15x1,5
11	44.00.232		Fixing device f. pump steam generator
12	44.00.210		Drain hose steam generator
13	2066.0518		Hose clamp 30mm
14	40.00.291		Thermocouple steam generator
15	1104.0122		Hex combination nut M4 galv
16	2112.1006		Steam hose 50x7mm
17	2066.0504		Hose clamp 40-60mm
18	2066.0506		Hose clamp 20-32mm
19	1105.0120		Hex nut M5
20	1205.0120		Tooth lock washer A5,3
21	2920.1300		Level elektrode insert
22	10.00.414		Cable strap black 120°

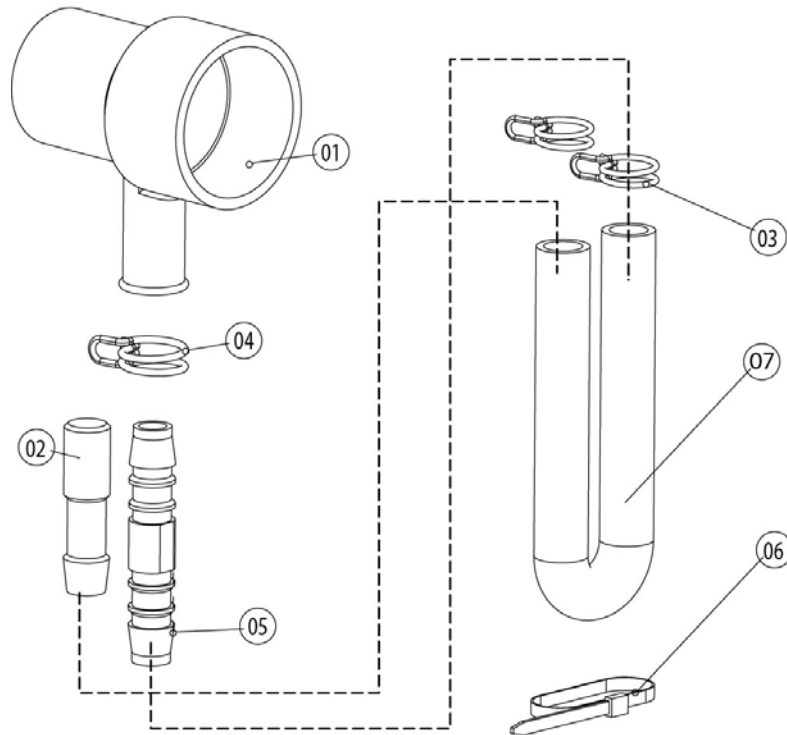

Item no.	Part no	Reference	Description
1	2118.1000		Pump connection spout
2	2120.1259		Stop plug 10mm
3	2066.0527		Hose clamp ø14mm
4	2066.0530		Hose clamp ø16.4mm
5	2062.0331		Junction pressure hose GS 10
6	4005.0101		Tie rap 145 mm

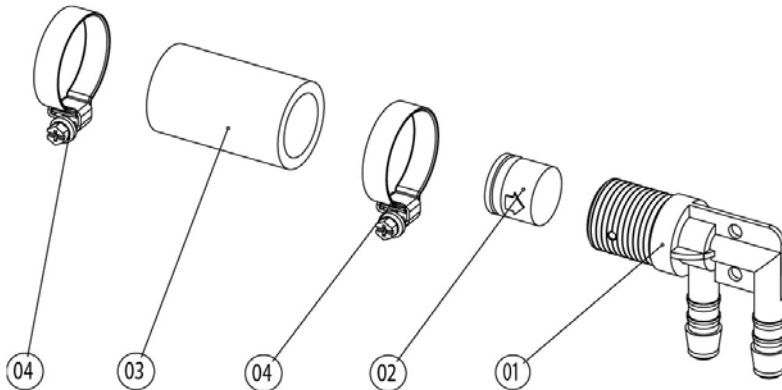

Item no.	Part no	Reference	Description
1	2062.0332		Receptacle for ventilation valve SG
2	2069.0108		Ventilation valve
3	2112.1310		Form hose for ventilation of steam generator
4	2066.0506		Hose clamp 20-32mm

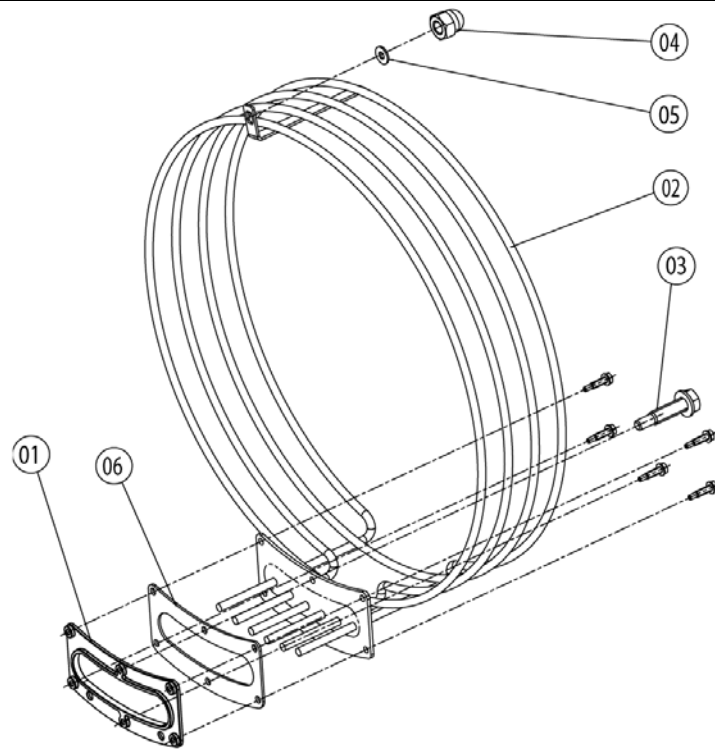

Item no.	Part no	Reference	Description
1	40.00.305		Mating flange f. heating assembly
2	40.00.251		Heating assembly
3	10.00.109		Hex screw M5x23
4	1106.0360		Cap nut M6, high shape
5	1306.0222		Washer A6,4x15x1,5
6	40.00.332		Gasket f. heating assembly

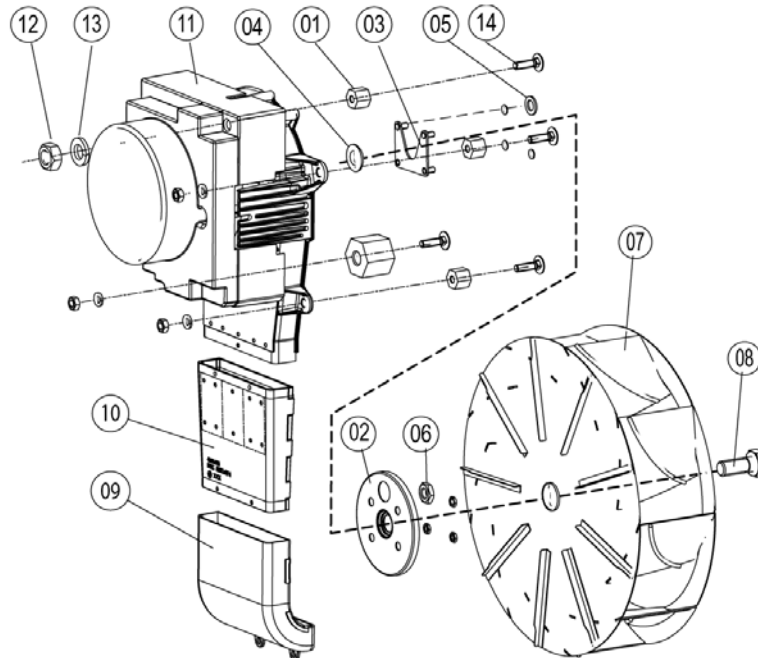

Item no.	Part no	Reference	Description
1	2120.1306		Spacer SW19x17
2	22.00.123		Flange f. motor shaft gasket
3	22.00.120		Mounting support f. gasket flange
4	22.00.083		Motor shaft gasket
5	1315.0101		Copper washer 6x10
6	1106.0220		Hex nut M6 flat
7	22.00.188		Fan wheel d340x110
8	1008.0763		Hex screw M8x20
8	10.00.565		Hex screw M8x20
9	40.00.310		Exhaust pipe below
11	40.00.274		Fan motor
12	10.00.071		Hex nut M8
12	1108.0260		Hex nut M8
12	10.00.710		Hex nut M8 w. locking
13	1208.0260		Spring washer B8
14	1008.1005		Square necked mushroom head bolt 8x40

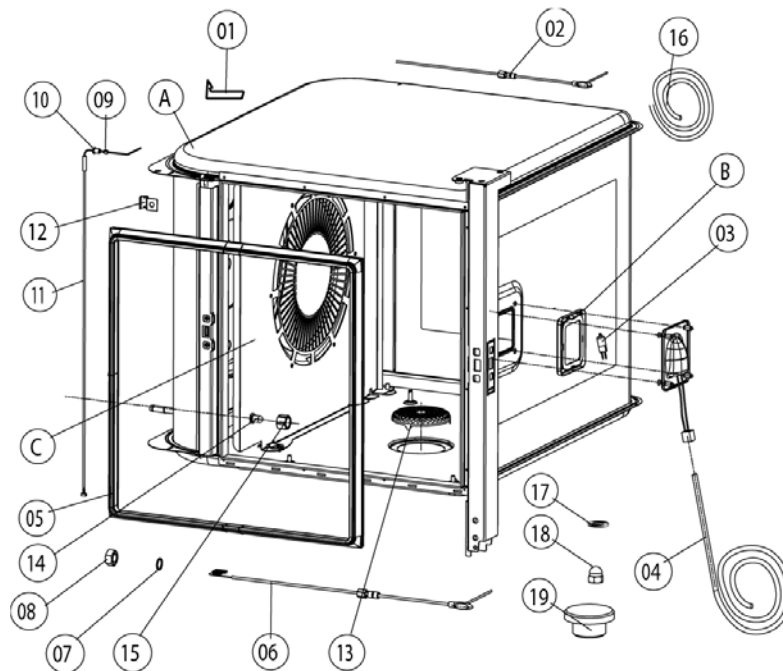

Item no.	Part no	Reference	Description
A		▶7.A	Interior cabinet
B	40.00.091	▶7.B	Gasket frame w. glass a. gaskets
C	22.00.293	▶7.C	Air baffle
1	40.00.520		Screen interior cabinet sensor
3	3024.0201		Halogen bulb for interior cabinet 300°C
4	40.00.222		Wiring interior light
5	20.00.394		Door gasket
6	40.00.296		Meat probe sensor
7	1315.0104		Copper washer 16x20x1,5
8	10.00.422		Hex nut M16
9	3014.0162		Sealing cone for thermocouple
10	3014.0163		Gasket sleeve with nipple
11	40.00.395		Thermocouple interior cabinet
12	2760.1089		Guide bush for core temperatur sensor
13	2005.0308		Outlet sieve

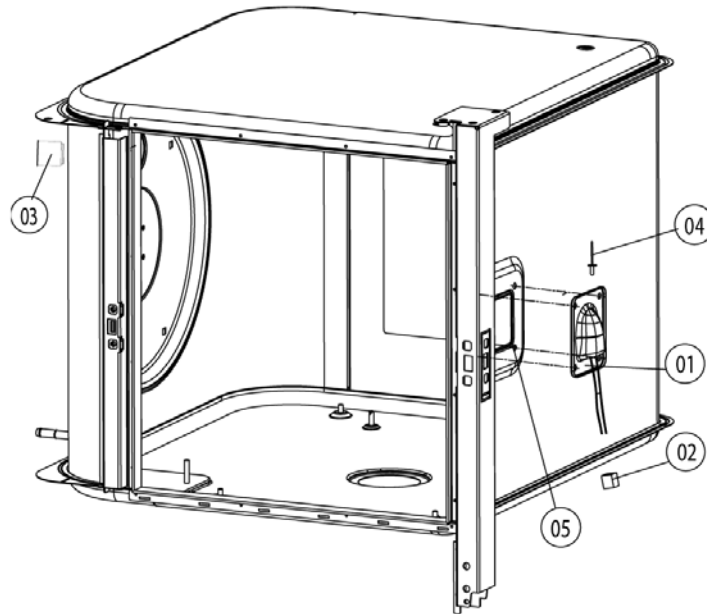

Item no.	Part no	Reference	Description
1	40.00.098		Reflector f. interior light
2	4001.1248		Porcelain connector 2-pin interior light
3	2120.1277		Base for sensor connection
4	1603.0167		Tubular rivet 3,2x0.25x10
5	10.00.041		Rivet nut M5 hexagon closed

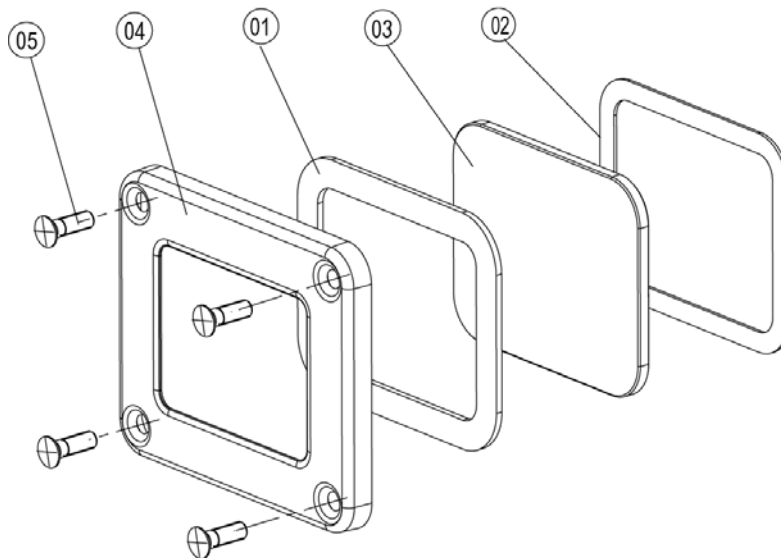

Item no.	Part no	Reference	Description
1	40.00.093		Outer gasket f. interior light
2	40.00.094		Inner gasket f. interior light
3	40.00.095		Glass pane f. interior light
4	40.00.096		Gasket frame f. interior light
5	10.00.682		Phillips countersunk-head screw M5x16

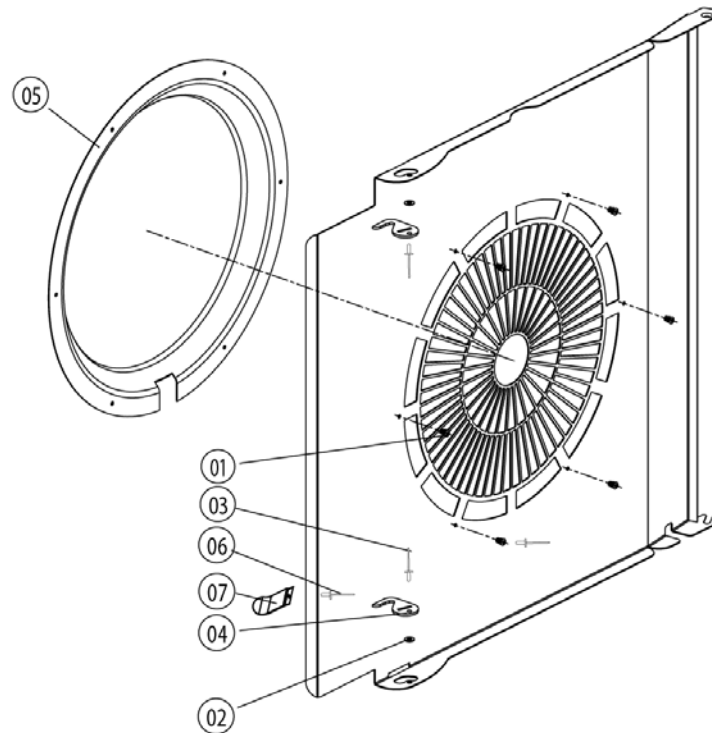

Item no.	Part no	Reference	Description
1	1603.0168		Rivet 3,2x8 A4
2	1304.0160		Washer A4,3
3	1604.0167		Rivet 4x10
4	2760.1370		Latch hook for air baffle
5	22.00.332		Air sucking ring f. air baffle
6	10.00.515		Rivet 3,2x5 A4
7	22.00.484		Swing protection for core probe

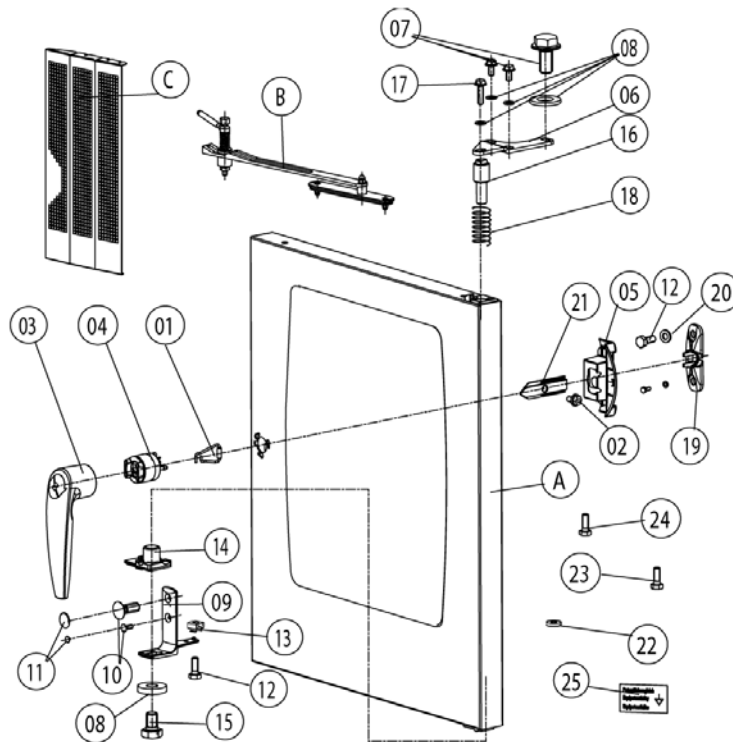

Item no.	Part no	Reference	Description
A	24.00.088	►8.A	Door
1	24.01.100		Spring clip f. door lock
2	1005.2000		Interlocking tooth screw M5x8
3	24.00.152		Door handle
4	24.00.176		Door lock
5	24.00.504		Lock cover
6	24.00.133		Door mounting support top
7	1008.0768		Ornamental screw M8x16
8	1308.0162		Washer A8,4
9	24.00.223		Door mounting support bottom
10	1006.1962		Countersunk screw Torx M6x16
11	10.00.090		Cap f. Torx T30
12	1006.0760		Hex screw M6x16
13	1106.0802		Cage nut M6
14	24.00.137		Door bolt
15	10.00.099		Hex screw M8x12
16	24.00.048		Door bolt
17	1008.0769		Ornamental screw M8x30
18	2001.0109		Compression spring
19	24.00.141		Holding bracket f. door catch
20	1306.0120		Washer A6,4
21	24.00.142		Door catch
22	1308.0160		Washer A8,4
23	24.01.200		Pan head screw Torx M4x12 T20
24	24.01.199		Slotted pan head screw M6x45 *WDS*

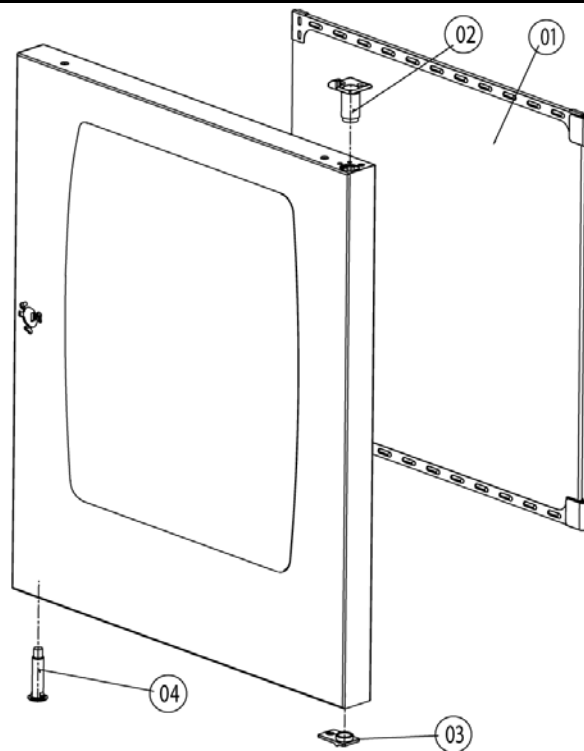

Item no.	Part no	Reference	Description
1	24.00.163		Inner door pane
2	24.00.147		Sleeve for door bolt top
3	24.00.146		Door setting bolt
4	24.00.502		Fixing device f. magnet with magnet

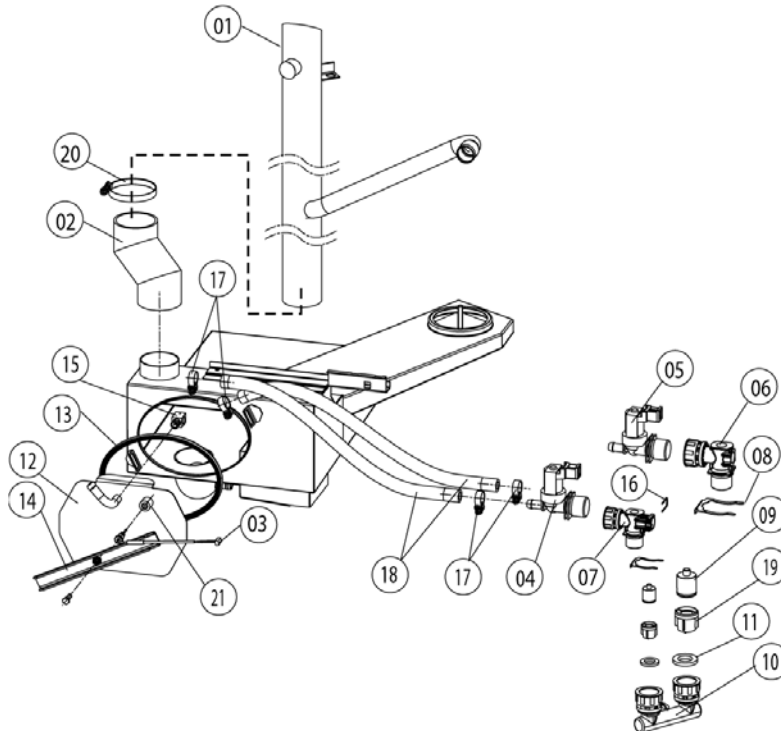

Item no.	Part no	Reference	Description
2	54.00.086		Rubber form piece venting pipe
3	40.00.287		Thermocouple quenching
4	50.00.316		Single solenoid valve
5	50.00.139		Single solenoid valve
6	50.00.071		Water distribution hor. w/o roll guide con.
8	50.00.086		Locking plate f. water distribution
9	50.00.078		Non return valve DW16/DN12
10	8664.1301		T-fitting water connection
11	5110.1024		Gasket for G3/4" threaded joint
12	54.00.228		Inspection lid f. quenching chamber
13	5012.0566		Gasket quenching chamber O-ring
14	54.00.225		Clamping bar
15	2016.0915		Quenching nozzle top
17	2066.0205		Hose clamp 8-16x9 mm SW 7mm
18	2067.0050		Pressure hose d10mm
19	1900.0202		Water filter
21	2120.1277		Base for sensor connection

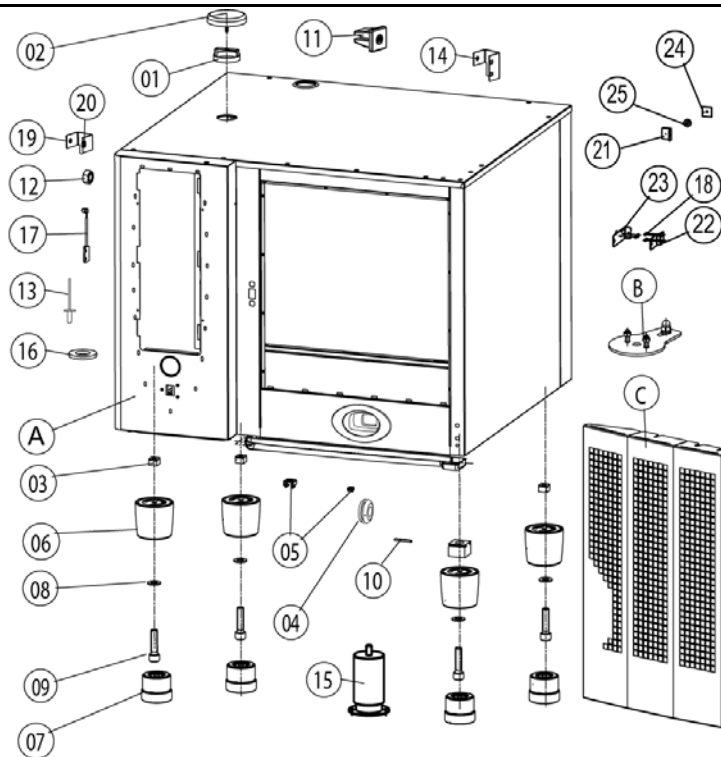

Item no.	Part no	Reference	Description
A		►13.A	Exterior cabinet
1	22.00.354		Spacer ring
1	8450.1310		Spacer ring
2	22.00.353		Vent cover
2	8455.1209		Vent cover
3	1110.0800		Cage nut M10
4	2022.0101		Grommet 18 mm
5	1106.0802		Cage nut M6
6	12.00.205		Upper part of pedestal
7	12.00.206		Lower part of pedestal
8	1328.0102		Safety washer A10,2
9	10.00.107		Allen screw M10x30
14	16.01.146		Bracket for door contact switch
17	40.00.335		Door switch

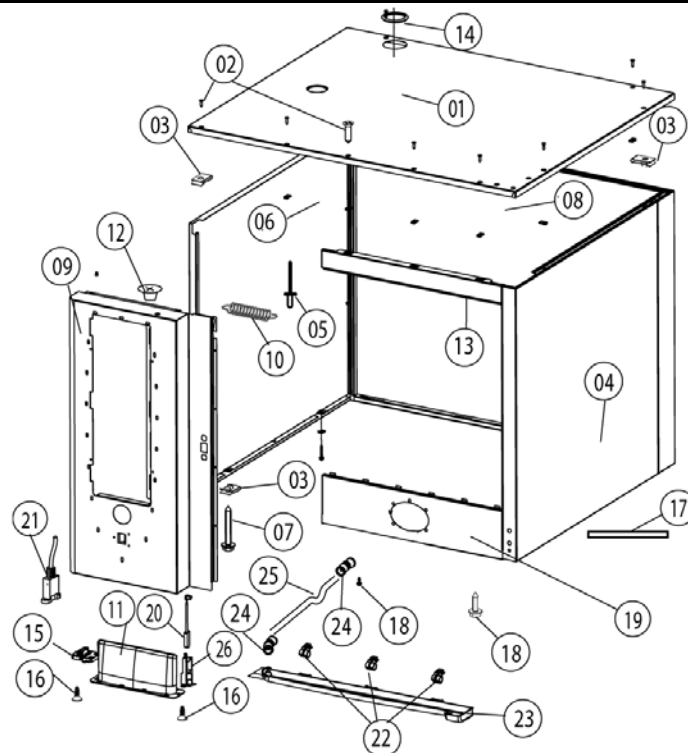

Item no.	Part no	Reference	Description
1	16.00.163		Top cover
2	1003.2265		Countersunk self tapping screw 4,2x16
3	1104.0820		Snap nut 4,2mm
4	16.00.135		Side panel right
5	1603.0166		Rivet 3,2x7,9 CNS closed
6	16.00.136		Side panel left
7	10.00.102		Hex self tapping screw B4,2x32
8	16.00.187		Back panel
9	16.00.294		Front panel
10	2002.0107		Tension spring for front panel
11	16.00.673		Air inlet filter
12	2039.0331		Cap for service door
13	16.00.180		Crossbar top
14	5105.1027		Gasket f. exhaust pipe d=54mm
15	16.00.360		Cover f. RS232 interface
16	10.00.103		EJOT PT-screw KA 3.5x10
17	16.00.338		Edge protection profile
18	1004.2160		Hex self tapping screw 4,2x16
19	16.00.181		Crossbar below
20	40.00.454		Door switch 1.65m
22	50.00.296		Clip f. drip collector
23	50.00.286		Drip collector
24	50.00.303		Bushing drip collector
25	50.00.556		Drain drip collector
25	50.00.299		Drain drip collector
26	16.00.384		Bracket for door contact switch

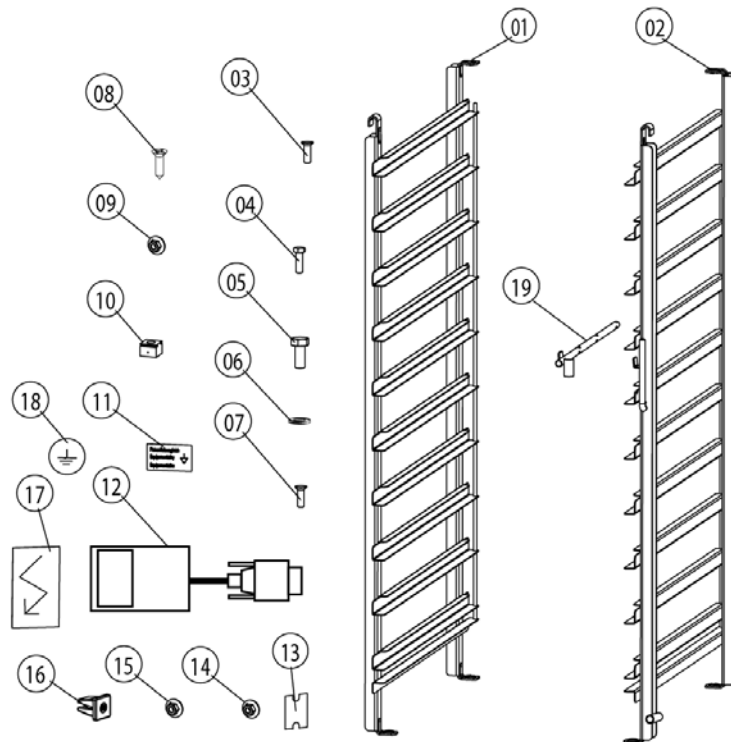

Item no.	Part no	Reference	Description
1	60.61.016		Hinging rack left
2	60.61.017		Hinging rack right
3	10.00.448		Phillips countersunk-head screw M5x16
4	1008.0750		Hex screw M5x16
5	10.00.565		Hex screw M8x20
6	1208.0160		Tooth lock washer A8,4
12	42.00.030		Memory-Stick
15	1105.0123		Hex combination nut M4
17	4019.0008		Sticker Electric/Danger
19	60.60.574		Positioning support f. core sensor