



IMPORTANT FOR FUTURE REFERENCE

Please complete this information and retain this manual for the life of the equipment:

Model #: _____

Serial #: _____

Date Purchased: _____

ENGLISH

Installation and Operation Manual Covering Models P90K

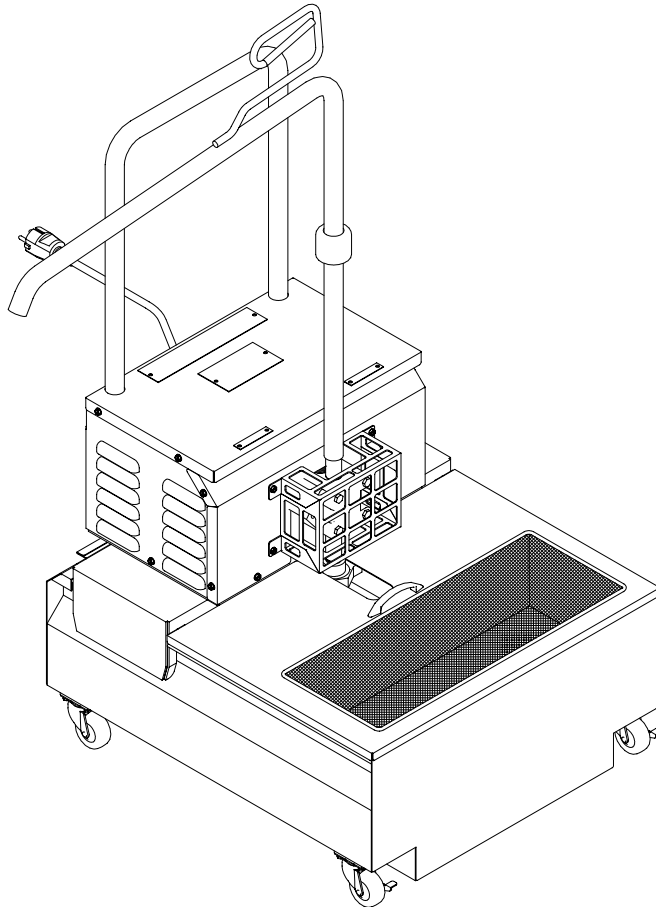

THIS MANUAL MUST BE RETAINED FOR FUTURE REFERENCE

WARNING

When working with HOT oil, protective clothing should be used. This should include, but not be limited to, insulated rubber gloves, eye protection or face mask and long sleeves.

WARNING

This machine is designed to operate on a specific voltage. This information can be found on the data plate located on the rear of the machine.

WARNING

This machine is designed for use by professional, trained personnel in the commercial cooking industry and, as such, should only be used in commercial applications by trained personnel.

WARNING

These appliances are not Jet Stream approved and therefore are not allowed to be splashed with water.

ATTENTION!

Do not operate the filter pump for more than three filter cycles at one time to prevent overheating of the pump motor.

ATTENTION

The power cord shall only be replaced by the Authorized Service Agent because special tools are required.

TABLE OF CONTENTS

ASSEMBLY.....	3
OPERATION	3
CLEANING.....	3
TROUBLESHOOTING	4
SCHEMATICS.....	4

ASSEMBLY

Place the Paper Support Rack inside the filter envelope so that the threaded coupling fits into the hole cut in the top of the paper. Fold the open end of the filter envelope over two times and push the Clip over folded end of filter envelope. Thread the Pick Up Tube onto the threaded coupling and hand tighten. Insert filter envelope assembly into filter pan and connect the Pick Up Tube Union to the Pump assembly.

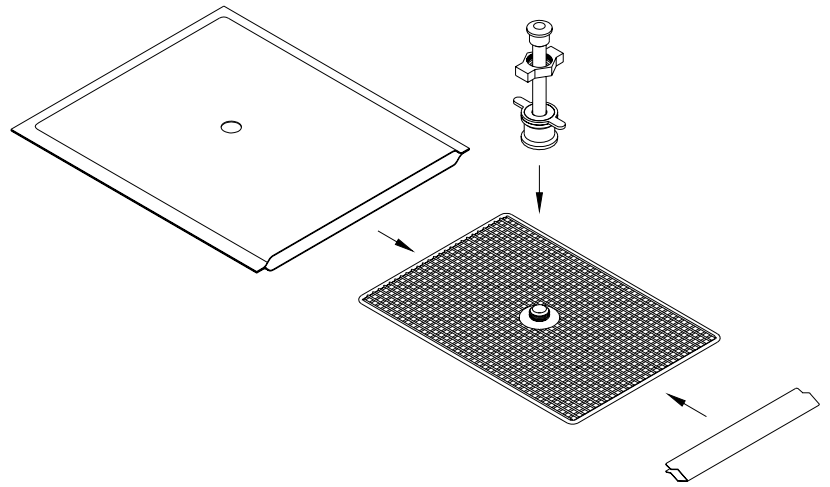

Sprinkle filter powder over filter envelope assembly, if desired.

Install Filter Pan Cover onto Filter Pan and Filter Crumb Catch into Filter Pan Cover.

OPERATION

Push the filter unit up to the fryer to be filtered and plug in the power cord into the electrical supply. Screw the draining adapter into the fryer drain valve so that the oil can be drained into the filter. Adjust location of filter pan so drain adapter will drain into Filter Crumb Catch. Turn fryer off. Carefully open the drain valve and drain the oil into the filter pan.

Position Refill Tube outlet over the fry pot of the fryer. Press the power switch to the On position and allow the oil to return to the fry pot. The returning oil will wash any remaining debris from the bottom of the fry pot. When the fry pot is clear close drain valve and return all of the oil.

After all the oil has been returned to the fry tank the filter will begin to pump air, this will be evident by a significantly reduced flow from the Refill Tube. Allow filter to pump air for about 15 seconds, press the power switch to the OFF position. The filtering process is now complete.

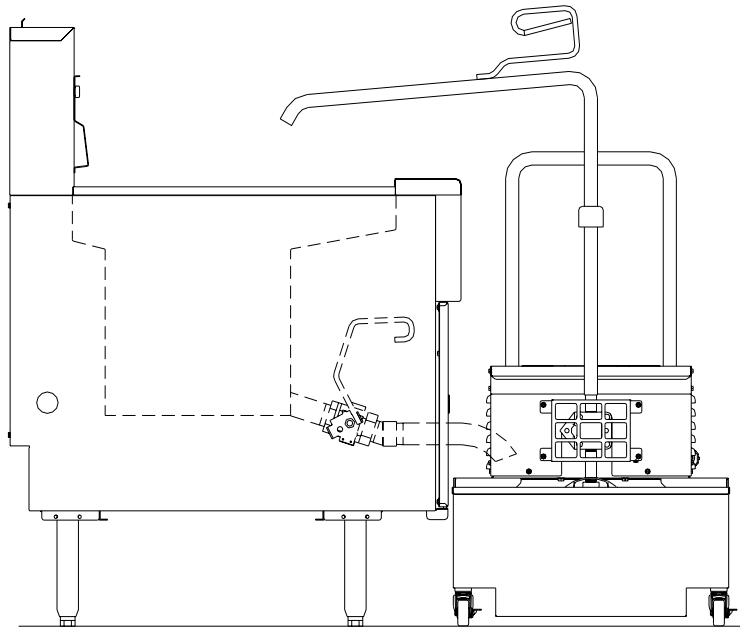

To allow oil to drain from refill tube, wait 15 seconds after filtering is completed to move filter.

CLEANING

Disassemble filter pan and remove Filter Pump assembly from filter pan. Clean with a general degreasing detergent, rinse with fresh water and dry thoroughly. All components that can be removed from the filter unit may be cleaned in a dish washer. This is generally a good time to install a fresh filter paper in preparation for the next filtering.

TROUBLESHOOTING

Pump does not run	Check circuit breaker
Pump does not run, power is present at the machine, circuit breaker is NOT tripped	Check the motor overheat trip switch located on the end of the motor
Pump is running, but oil is not being pumped	Check for blockages in piping and return hose
Air bubbles are present when oil is being pumped	There is an air leak on the suction side of the pump, check filter connections

SCHEMATICS

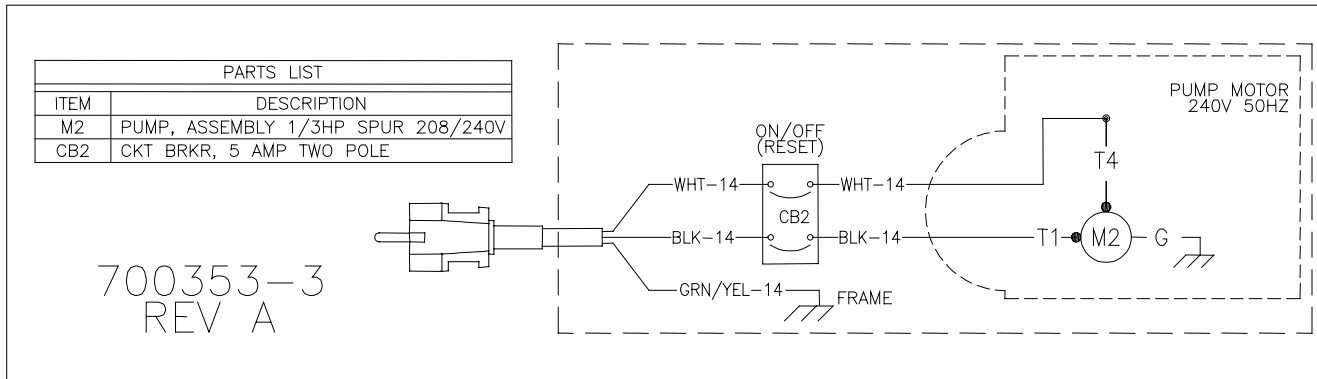
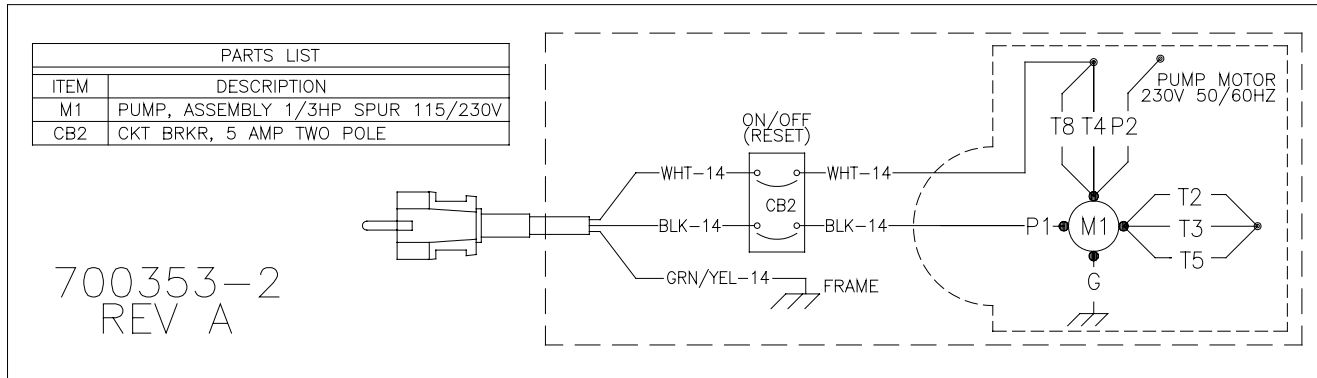

In the event of problems with or questions about your order, please contact the Pitco Frialator factory at:
(800) 258-3708 US and Canada only or
(603) 225-6684 World Wide

In the event of problems with or questions about your equipment please contact the Pitco Frialator Authorized Service and Parts Representative (ASAP) covering your area or contact Pitco at the numbers listed to the left.

MAILING ADDRESS – P.O. BOX 501, CONCORD, NH 03302-0501
SHIPPING ADDRESS – 10 FERRY ST., CONCORD, NH 03301