



NU-VU® Model:

SUB-123P

Oven / Proofer

A Quality Product Made in the U.S.A.

Manufactured exclusively for:



by:

NU-VU® Food Service Systems

5600 13th STREET

MENOMINEE, MICHIGAN 49858-1029

(906) 863-4401 FAX (906) 863-5889

Revised:
07 May 2009

(This page is intentionally left blank)

Dear Customer:

Thank you for buying NU-VU® equipment. We think you have purchased one of the best units on the market today.

Every piece of NU-VU® equipment is put through a full electrical test. In addition, NU-VU® ovens are randomly selected for test baking to ensure you are receiving the best product possible. The interior of the oven may darken slightly during this testing process. This coloration is normal and occurs in any oven that has been operated for a few hours. It will not affect the operation, durability or warranty of your NU-VU® equipment.

This OWNER'S MANUAL has been put together to give you a good general knowledge of your equipment. It is not a detailed technical manual; such a book is unnecessary for the daily care and operation of your unit. However, this Manual *does* contain some basic trouble-shooting and service information. If this OWNER'S MANUAL does not answer your questions or solve your problems please call us at (906) 863-4401. You can also fax your question or comment to our Service Department at (906) 863-6322. You can even e-mail us at service@nu-vu.com. One of our service technicians will be glad to assist you. Please remember to supply the model number, serial number and the manufacturing date code of your NU-VU® equipment when you contact us.

Each page carries information to help you use this OWNER'S MANUAL. The header at the top of each page contains the title of the section you are currently in. The footer at the bottom of each page carries the page number, our telephone number, and our Sales and Service fax numbers.

All sections begin at the top of a page and start like this:

SECTION HEADING

All sub-section headings are on the left side of each page and look like this:

SUB-SECTION HEADING:

SUB-SECTION HEADING - -

Pointing hands are located in the left margin throughout this OWNER'S MANUAL, and point toward shaded boxes containing important warning and/or safety information:



IMPORTANT: THESE SHADED BOXES WILL CONTAIN IMPORTANT WARNING, OPERATING AND/OR SAFETY INFORMATION!

The illustrations used throughout this OWNER'S MANUAL are titled in their lower left-hand corners. A complete list of these illustrations, along with their respective page numbers, can be found on page *iv* of this manual. A REPLACEMENT PARTS LIST can be found at the end of this manual. Replacement parts are listed by Reference Number. The part Reference Numbers are circled ○ in the illustrations and bracketed [] in the text. Please note that some of the parts listed are not replaceable except as part of another assembly, but are listed for reference and identification only.

Electrical schematics are also included at the end of this OWNER'S MANUAL for use as reference aids only. Please contact our Service Department for specific electrical information.

(This page is intentionally left blank)

TABLE OF CONTENTS

ABOUT YOUR SUB-123P	1
SUB-123P Specifications	2
RECEIPT, INSTALLATION AND START-UP	
Receipt	3
Installation	4
Connection of Electrical Supply	4
Connection of Water Supply	5
Start-Up	
Oven	6
Standard AUTOMIST Proofer	7
OPERATING INSTRUCTIONS	
Proofer	
For the Standard AUTOMIST Proofer	8
Oven	9
PROGRAMMABLE CONTROLLER	10
MAINTENANCE AND CLEANING GUIDE	
Maintenance	19
AUTOMIST Proofer Dry-Out Procedure	19
Oven Dry-Out Procedure	19
Cleaning	20
SERVICE AND REPLACEMENT GUIDE	21
Door Latch, How to Adjust	22
Door Test Procedure	22
Door Gasket, How to Replace	23
Replacing the Oven Door Gasket	23
Replacing the Proofer Door Gasket	24
NU-VU® EQUIPMENT WARRANTY	
Parts	25
Labor	25
Warranty Limitations	26
Parts Return Procedure and Conditions	27
REPLACEMENT PARTS LIST	
Electrical Components	28
Door Components	28
Oven Interior Components	29
Proofer Interior Components (AUTOMIST).....	29
General Exterior Components	29
ELECTRICAL SCHEMATICS	30

*** * * NOTICE * * ***

Record the Model Number and Serial Number from the nameplate on the side of your unit on page 27 in the WARRANTY section for future reference. Please be ready to give these numbers to our Service Department when ordering replacement parts or requesting service.

**LIST OF
ILLUSTRATIONS AND SCHEMATICS**

Fig. #1	Installation	3
Fig. #2	Power Supply Connections	5
Fig. #3	Oven & Proofer Controls	8
Fig. #4.....	Door Latch Assembly	22
Fig. #5	Door Gasket	23
Electrical Schematics		30

(This page is intentionally left blank)

ABOUT YOUR SUB-123P

The NU-VU® SUB-123P is an electrically powered and operated commercial baking/cooking appliance. It does not require exterior venting under normal circumstances; however, hood and venting requirements vary from country to country, state to state, and even from locality to locality. For this reason, NU-VU® cannot give specific detailed information regarding your individual application. Your local building inspector, licensed contractor, or installer is best qualified to determine your specific needs.

The oven section of the SUB-123P features our patented V-AIR® air movement system. A top-mounted blower moves the air down through the side walls to be heated, then out through specially designed hole patterns to provide even heat distribution throughout the oven. Your product is baked evenly from top to bottom, side to side, front to back without turning pans. You can load the oven completely with pans having the same product, bake, and remove the entire load at the same time. The bake is uniform because each shelf now receives essentially the same air pattern.

The oven compartment can hold up to three (3) full size 18"x26" sheet pans, or six (6) half-size 13"x18" sheet pans on the included chrome-plated wire shelves.

The proofer compartment can hold up to nine (9) full size 18"x26" sheet pans, or eighteen (18) 13"x18" half-size sheet pans on the included chrome-plated wire shelves. A total of twelve (12) chrome plated wire shelves are included for use in the oven and proofer.

Measuring 77¾" high, 36½" wide and 28 5/8" deep, the entire unit takes up less than 7½ square feet of floor space. It is constructed of stainless steel both inside and out. The front and back frames are cut from single sheets of stainless steel. These frames then are welded to the stainless base and top headers to form a unit with superior durability and rigidity. Components such as temperature and humidity controls, timers, switches, motors, heating elements, and others are thoroughly tested before shipment. Ongoing research and development projects are used to introduce the latest and most dependable components.

The NU-VU® SUB-123P is designed for:

- Automatic pan positioning
- Rapid and even baking
- Easy cleaning
- Simple operation
- Dependability
- Low energy consumption
- Low maintenance
- Rapid servicing

The *AUTOMIST* option eliminates the manually filled water pan in the proofer, but requires connection to a pressurized potable water supply. An adjustable water mist is injected into the blower wheel in the bottom of the proofer. The blower wheel then distributes this water mist evenly throughout the proofer compartment to provide the controlled humidity necessary for proper proofing action.

RECEIPT, INSTALLATION AND START-UP

RECEIPT:

It is essential to inspect the unit immediately when it arrives. NU-VU® has placed instructions on the packaging to help avoid damage in transit. However, negligent handling can produce hidden damage.

These steps should be followed:

- A. Inspect the entire perimeter of the package for damage or punctures to the packing material. This may indicate damage to the unit inside. Call any and all packing damage to the attention of the delivery person.
- B. If any package damage is found uncrate the unit immediately *in the presence of the delivery person* to determine if the unit is damaged. Pay special attention to the top of the unit. Make sure it is not bent or otherwise damaged, which may occur if the top of the unit has struck a door frame or the top of a trailer. If any damage is found indicate the type and amount of damage on the shipping documents and notify NU-VU® at (906) 863-4401 immediately after filing a freight claim.
- C. Uncrate the unit carefully and check the entire unit (top, front, back, and both sides) for any visible or hidden damage.
- D. Remove the unit from the shipping pallet and inspect the bottom (including the Casters) for any damage. Check the Casters and the Proofer Motor/Cover under the unit.
- E. If any damage is noted after the driver leaves immediately contact the freight company and NU-VU® Food Service Systems.
- F. Check the Oven and Proofer Doors. Make sure both Doors close completely, and that the Door Gaskets seal firmly (refer to the *DOOR TEST PROCEDURE* in the *SERVICE AND REPLACEMENT GUIDE*). If they do not close or seal properly please contact the NU-VU® Service Department for instructions and assistance in any required adjustments.
- G. Count the number of Shelves included. There should be a total of twelve (12) Shelves (nine for the Proofer, three for the Oven). Contact NU-VU® immediately concerning any shortage.

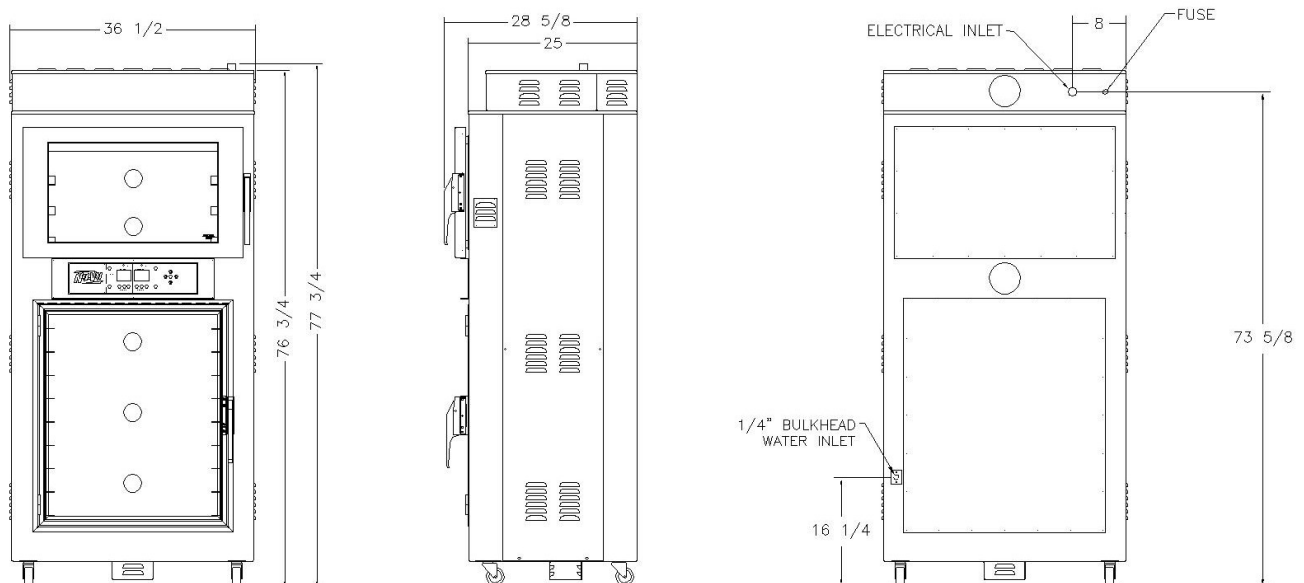

Fig. #1 - Installation

INSTALLATION:

Record the Model Number and complete Serial Number of your unit in the spaces provided on page 27 of this manual. You will need these numbers if you should ever need to contact our Service Department concerning adjustments, replacement parts or other service needs.

Roll the unit into the exact position where it is to be operated. Make sure there will be enough clearance on each side of the unit for proper cooling during operation, and for ease of access during maintenance or service. NU-VU® recommends a minimum clearance of 4" at the back and both sides of the unit. Mark the locations of the electrical and optional water connections on the wall.

Check the swing of both the Oven and Proofer Doors, making sure they have enough room to open completely without hitting anything or obstructing the work area.

Move the unit out from its operating position and proceed with the service connections.

Connection of Electrical Supply - -

Check to determine that the power source is the same voltage and phase as that indicated on the label on the side of the unit. If the voltage or phase *is not* the same, please call NU-VU® service department at (906) 863-4401.

IMPORTANT: DO NOT CONNECT THIS UNIT IF YOUR POWER SOURCE DOES NOT MATCH THE REQUIREMENTS AS LISTED ON THE UNIT LABEL!

This equipment must be installed and connected in accordance with all applicable federal, state, province, and/or local electrical codes having jurisdiction. All electrical connections must be made with COPPER WIRE ONLY in the correct gauge for the application. The unit may be connected either through a plug and receptacle-type connection or direct wiring. Allow enough slack in the wiring to allow for equipment to be moved during installation or any required maintenance and servicing.

WARNING: ALL POWER MUST BE TURNED OFF AT THE ELECTRICAL SUPPLY WHILE THIS UNIT IS BEING CONNECTED!

The electrician should remove the Outside Top [71] to expose the power supply connections at the Power Terminal Block [1] on top of the oven compartment. A wiring schematic is attached to the wiring near the power terminal connections.

Proper electrical connections will vary depending on the voltage, phase and frequency requirements of the unit and available power supply. The following instructions are for the most common 120/208 volt or 120/240 volt configurations (refer to *Fig. #2* on page 5), and may be modified to fit your installation.

- A. The electrician must install a cable clamping device or cord restraint in the rear access hole. This cable clamping device must be firmly attached to the unit, and appropriately sized for the power supply wire or cord being used.
- B. Take note of the labeling on the Oven terminal connections (Line 1, Line 2, Line 3, and Neutral) at the Power Terminal Block [1].
- C. Carefully identify the power source connections and attach them to the appropriate terminals. Make sure all connections are clean and tight.

IMPORTANT: IN A THREE PHASE SYSTEM ANY WILD LEG (MORE THAN 120 VOLTS TO NEUTRAL) MUST ALWAYS BE CONNECTED TO L-2!

- D. Be sure the unit is properly grounded BEFORE use by attaching a grounding wire to the Ground Lug [2] next to the Power Terminal Block.

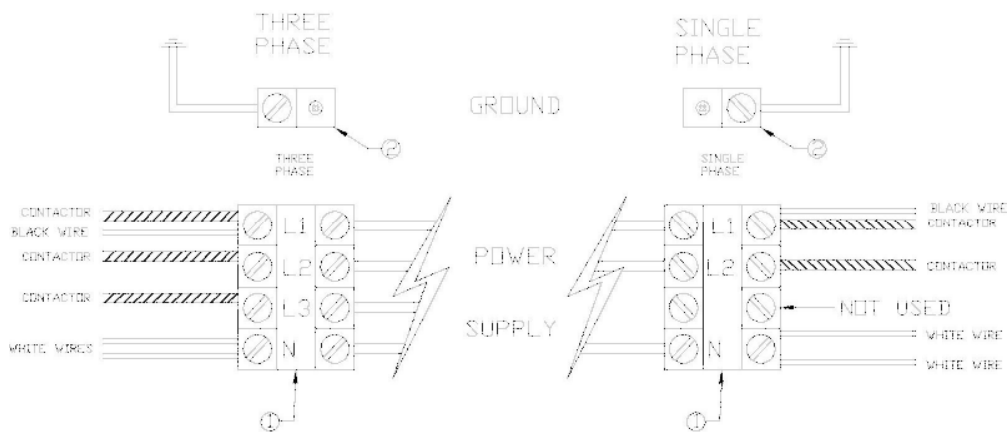

Fig. #2 – Power Supply Connections

- E. Engage the main power supply.
- F. Check the voltage at the terminals on the Power Terminal Block with a voltmeter and compare the readings with the label listings on the side of the unit. If the readings match, the unit is ready for its initial START-UP. If the readings **DO NOT** coincide you must call the NU-VU[®] Service Department.
- G. Install any required or desired drain plumbing to the drain fitting in the base of the unit directly under the proofer compartment.
- H. Replace the Outside Top. Be careful not to pull or pinch any wires while installing the Panel.
- I. Install nine of the supplied Shelves [65] in the Proofer. The other Shelves are used in the Oven.
- J. Push the unit back into place and set the brakes on the front Casters.
- K. The Proofer compartment of the NU-VU[®] SUB-123P is equipped with a bottom drain centered directly under the Proofer Door. Please install the included Drain Pan [77] in the brackets under the Proofer *if you have not already installed drain plumbing*. This drain prevents the build-up of excessive water that may damage the Proofer Motor, Heating Element, or a Sensor.

Connection of Water Supply - -

This equipment must be installed in accordance with all applicable federal, state, province, and/or local plumbing codes having jurisdiction.

NU-VU[®] strongly recommends that **SOFT WATER ONLY** be used in any unit requiring a water supply. Also, a good quality water filter must be installed in-line between the unit connection and the water supply to guard against clogging and mineral build-up in the components. This is extremely important in areas having hard water. The water filter may be installed at the water source, adjacent to the water inlet on the unit, or anywhere in between, whichever is more convenient for you.

- A. Run 1/4" OD tubing from the water supply line to the unit location. Allow some slack in the tubing for final unit positioning and any future service requirements. Avoid any kinks or strains on the tubing, and position the tubing where it will not be damaged in any way.
- B. The tubing end that attaches to the back of the unit must not be damaged or deformed in any way. The cut end should be cut straight and clean with no deforming of the tubing. All burrs and sharp or rough edges should be removed to ensure a proper and leak-free connection.
- C. Position the tubing so that it runs straight into the intake Water Fitting [76] on the rear of the unit. Be careful not to kink the tubing if you bend it, and do not bend the tubing within two (2) inches of the cut end.
- D. The two-part compression fitting (tapered collar and nut) is placed approximately 1" onto the end of the tubing so that the collar is inside of the nut and the threaded opening of the nut is toward the intake Water Fitting.

- E. Push the end of the tubing all the way into the intake Water Fitting (approximately 1/4") and hold it there while you thread the compression nut onto the intake Fitting. Tighten the compression nut with an open-end wrench, *but do not over-tighten the fitting!* If the joint leaks when tested, and further gently tightening does not stop the leakage, the compression fitting must be replaced.

Careful attention to these simple procedures will help to ensure an installation without leaks. If you have any questions or problems, please call the NU-VU® Service Department at (906) 863-4401.

IMPORTANT: Please be sure to install any desired or required drain plumbing at this time. Any required plumbing must be installed before attempting an INITIAL START-UP.

NOTE: Your SUB-123P is equipped with a Drain in the floor of the Proofer compartment. This Drain prevents the accumulation of excess water that may damage the Proofer Motor, Heating Element or a Control Sensor. Please slide the included Drain Pan [77] into the bracket under the Proofer Door to catch any draining water, OR position the Proofer Drain directly over a floor drain, OR attach a length of tubing or light hose to the Drain where it comes through the base of the unit and run it to a floor drain in the immediate area.

**YOUR NU-VU® SUB-123P SHOULD NOW BE
READY FOR ITS INITIAL START-UP!**

IMPORTANT: IMPROPER INSTALLATION, MISUSE, OR OTHER FAILURE TO FOLLOW THESE INSTRUCTIONS MAY CAUSE SEVERE EQUIPMENT DAMAGE OR PERSONAL INJURY. AND MAY ALSO VOID ALL OR PART OF YOUR NU-VU® WARRANTY!

*** * * Notice * * ***

National Sanitation Foundation (NSF) guidelines require that all interior parts be removable without the use of tools. This equipment has been factory assembled to safely accommodate rough handling through shipment, delivery and original installation. After any maintenance, cleaning or required service work the interior sheet metal parts should be reassembled and fastened hand-tight only, but still be tight enough to prevent any rattle or movement of parts.

START-UP:

Oven - -

(refer to Fig. #3 on page 9)

- A. Unscrew the glass Light Lenses [20] in the rear of the Oven. Install the included Appliance Bulbs (if they are not already installed) and replace the Lenses. Close the Oven Door [41] securely.
- B. Engage the main electrical and water supplies.
- C. Press the Oven On / Off Button to turn on the Oven portion of the controls. Upon powering up the Oven portion of the control, you will have the option of selecting the language you would like to be displayed by pressing the enter button. After approximately 3 seconds Recipe 1 will be automatically started. The controller is preprogrammed with Subway recommended baking time and temperature settings. Recipe 1 is for bread and Recipe 2 is for cookies. You may need to modify these settings for your location The interior of the Oven should illuminate and the Oven Blower Wheel [7] should begin to rotate.
- D. Open the Oven Door [41]. The Motor/Blower Wheel should come to a stop as the Door opens and the Micro Switch [15] in the Door Jamb is released.
- E. Place a reliable oven thermometer on a baking pan in the center of the Oven.
- F. Close the Oven Door securely. The Motor/Blower Wheel should restart.

- G. The Oven will begin heating to the Oven temperature set point. You may continue with the Oven Start-Up and even begin the Proofer Start-Up while the Oven heats.
- H. Press the Oven Start / Stop Button to begin the countdown timer. When the Oven time display reaches zero the Alarm [16] will sound. Before pressing the Oven Start / Stop button to silence the Alarm [16], you may want to adjust the volume baffle on the front of the alarm to the desired volume.
- I. Check the thermometer reading against the Oven Actual Display when the Oven Ready light comes on. The Alarm will sound to alert when the oven has reached the set point. If the readings differ by more than 10° the Temperature Control may need a simple adjustment. Please call the NU-VU® Service Department **BEFORE** attempting calibration or adjustment of the control.

***NOTE:** Please allow the Temperature Control to cycle two or three times to allow the Oven temperature to stabilize **BEFORE** comparing the readings.*

- J. Press the Oven On / Off Button to turn off the oven portion of the controller.

Standard AUTOMIST Proofer - -

(refer to *Fig. #3* on page 9)

- A. Unscrew the glass Light Lenses [20] in the rear of the Proofer. Install the included Appliance Bulbs (if they are not already installed) and replace the Lenses. Close the Proofer Door [42] securely.
- B. Press the Proofer On / Off Button to turn on the Proofer portion of the controls. Upon powering up the Proofer portion of the control, Recipe 1 will be automatically started. The controller is preprogrammed with Subway recommended Proofing time, temperature, and humidity settings. You may need to modify these settings for your location. The Proofer interior should illuminate and the Blower Wheel [11] should begin to rotate.
- C. A light water mist will be sprayed from the Injection Nozzle [67] into the Blower Wheel [11]. The spray should stop after one second. After a short pause (approximately 20 seconds) the Humidity Control and Injection Nozzle will cycle again. Set the Humidity Control to **OFF**.
- D. The Proofer will begin heating when a recipe is loaded.
- E. Place a reliable oven thermometer on a Proofer Shelf [65] in the center of the Proofer.
- F. When the Proofer Temperature set point is reached the Alarm [16] will sound. Check the thermometer reading against the Proofer Actual Temperature on the controller (refer to the Programmable Controller section of this manual if you are unsure of how to do this). If the readings differ by more than 5° the Temperature Control may need a simple adjustment. Please call the NU-VU® Service Department **BEFORE** attempting calibration or adjustment of the control.

***NOTE:** Please allow the Temperature Control to cycle two or three times to allow the Proofer temperature to stabilize **BEFORE** comparing the readings.*

- G. Press the Proofer On / Off Button to turn off the Proofer portion of the controller.

Your AUTOMIST SUB-123P is now ready to operate!

OPERATING INSTRUCTIONS

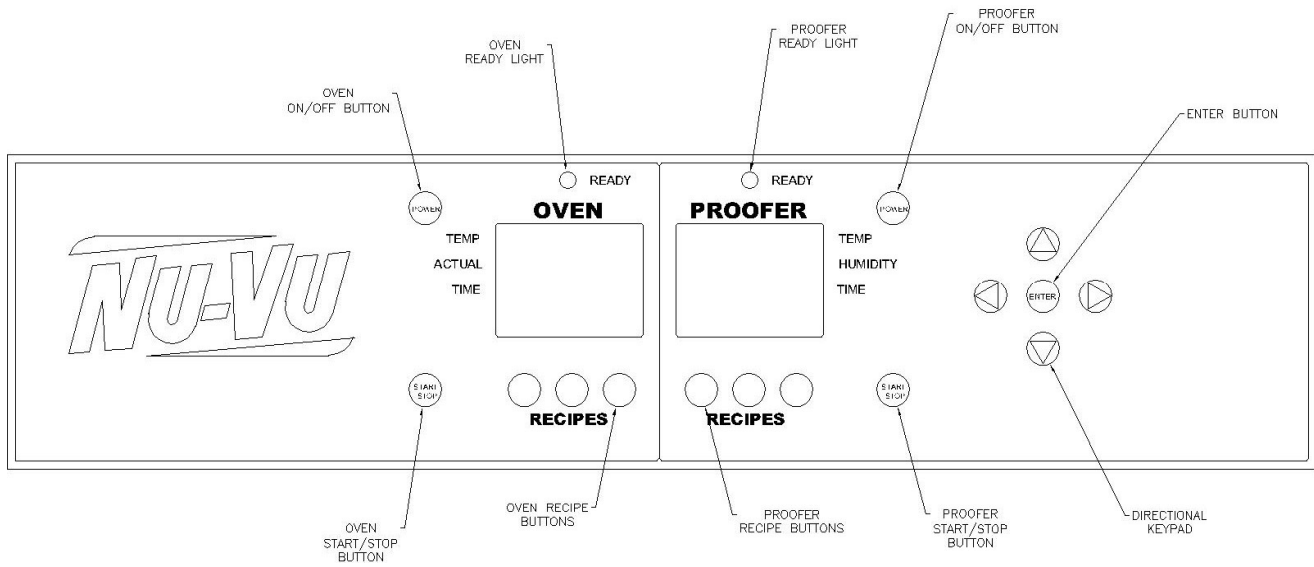

Fig. #3 –Oven & Proofer Controls

PROOFER:

For the Standard AUTOMIST Proofer - -

Begin to pre-heat the Proofer section of the SUB-123P about 20 to 30 minutes before its scheduled use.

- A. Set out the desired product for thawing. Be sure to allow sufficient time in your schedule for both the product and your equipment to reach the correct conditions.
- B. Prepare the Proofer:
 1. Press the Proofer On / Off Button to turn on the Proofer portion of the controls. Upon powering up the Proofer portion of the control, Recipe 1 will be automatically started. The controller is preprogrammed with Subway recommended Proofing time, temperature, and humidity settings. You may need to modify these settings for your location.
 2. Make sure water is being supplied to the Proofer. An AUTOMIST unit injects water directly into the air in the Proofer, raising the internal humidity level almost immediately.
 3. The Proofer is ready for use when the Proofer Ready Light comes on and a light to moderate fogging appears on the Proofer Door [42].

IMPORTANT: ALWAYS REDUCE THE HUMIDITY SETTING TO OFF WHEN OPERATING THE PROOFER FOR EXTENDED PERIODS WITHOUT ANY PRODUCT INSIDE!

- C. Load the product. The pans should be pushed all the way back and centered from side to side as much as possible on each Proofer Shelf to allow for proper air circulation over and around your product. If you are loading a single pan, center it on the Shelf from side to side and front to back.
- D. Press the Proofer Start / Stop to begin the countdown timer as a reminder to check your proof.
- F. Monitor the proofing process. Your Proofer is functioning properly if there is a light to moderate fogging on the Proofer Door. No fogging means your Proofer may be running too hot, too dry, or both. Excessive fogging (with water running down the glass) means your Proofer may be running too cold, too wet, or both. Check the product and adjust the Proofer Temperature and Humidity Controls as necessary.

***TIP:** If water accumulates on the floor in front of your Proofer from drippings out of the Proofer Door you are probably proofing with too much humidity. Decrease the Humidity Control setting. If water on the floor is a constant problem for you please call the NU-VU® Service Department at (906) 863-4401.*

- G. Load the Oven when your product is fully proofed. Yeast products should be 65% to 75% of the desired finished size at the end of the proof cycle. Generally speaking, properly proofed bread should have a soft, silky smooth feel to it when touched. It should never be anything more than slightly tacky. If the dough sticks to your finger and does not pull off cleanly, the dough is too wet.

OVEN:

Since your Oven requires time to reach the proper temperature, you must plan ahead so your Oven and product are ready at the same time. When the desired temperature is reached (about 15-20 minutes after start-up), the Oven Ready Light will come on.

 **WARNING: WE TRY TO "BURN OFF" ANY MANUFACTURING OILS INSIDE OF YOUR OVEN BEFORE SHIPMENT. HOWEVER, SOME OILS MAY REMAIN, CAUSING YOUR OVEN TO SMOKE DURING INITIAL OPERATION. SIMPLY ALLOW THE OVEN TO RUN AT 350°F FOR AN HOUR OR TWO TO COMPLETE THE BURN-OFF AND THE SMOKING SHOULD STOP. WE APOLOGIZE FOR ANY INCONVENIENCE THIS MAY CAUSE.**

To operate the Oven section:

- A. Press the Oven On / Off Button to turn on the Oven portion of the controls. Upon powering up the Oven portion of the control, you will have the option of selecting the language you would like to be displayed by pressing the enter button, after approximately 3 seconds Recipe 1 will be automatically started. The controller is preprogrammed with Subway recommended baking time and temperature settings. Recipe 1 is for bread and Recipe 2 is for cookies. You may need to modify these settings for your location. When the Oven Ready Light comes on the Oven is ready for baking.
- B. Load the Oven from the top down, placing a single full size pan or two half-size pans on each Shelf. Push the pans all the way to the rear, and center them from side to side. Single pans should be centered from side to side and front to back. If the top shelf is too high to be reached safely and easily, empty pans should be placed on the shelf to guide the air flow over and around your product for the best possible results.
- C. Close the Oven Door [41] securely. It is important to keep the Oven Door closed unless loading or removing product to maintain Oven temperature, reduce baking time, and minimize energy usage.

***NOTE:** It is helpful to slowly push the Oven Door closed until the Oven Motor restarts. Hold it about 1" from the closed position for only 1 or 2 seconds before latching it securely. This short delay prevents the build-up of internal air pressure that may suddenly "pop" the Oven Door open.*

- D. Press the Oven Start / Stop Button to start the count-down timer. The alarm will sound when the timer has reached zero.
- E. As soon as the product is finished baking, open the Oven Door and remove the product quickly. You can load more product into the Oven immediately, or close the Oven Door and allow the Oven to recover to the set baking temperature. Allowing the Oven a few minutes of recovery time results in a quicker and better bake.

 **CAUTION: STAND AWAY FROM THE FRONT OF THE OVEN WHEN OPENING THE OVEN DOOR AFTER A BAKING CYCLE TO AVOID EXPOSURE TO HEAT AND STEAM!**

- F. When all baking is done for the day, set both the Temperature Control and the Power Switch to **OFF** and complete the daily *DRY-OUT PROCEDURE* outlined in the *MAINTENANCE AND CLEANING GUIDE*.

PROGRAMMABLE CONTROLLER

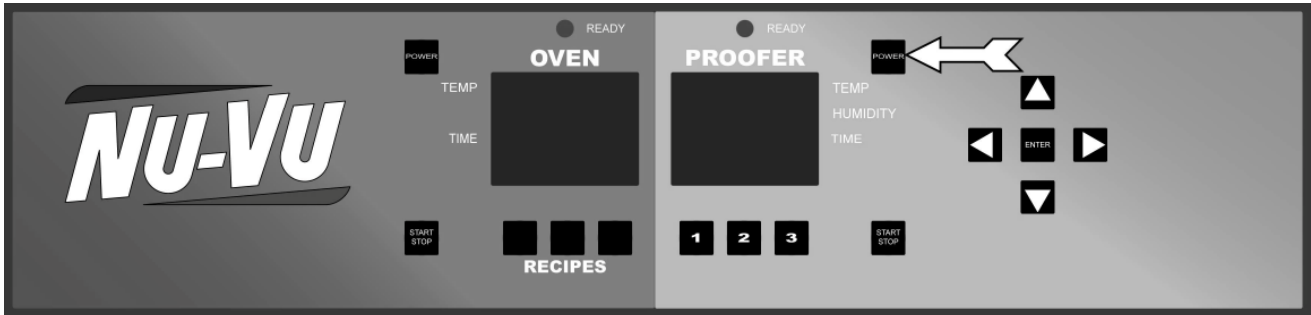

To turn on the controller, simply press either of the power buttons. The arrow points to the proofer power button.

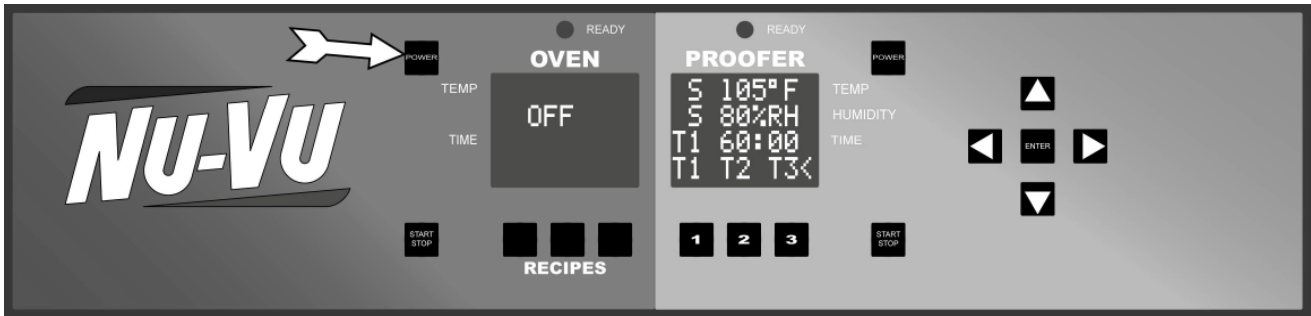

To turn on the oven portion of the controller, press the oven power button. The arrow points to the oven power button. The oven and proofer portions of the controller can be turned on and off independently. Upon turning on the oven portion of the controller, you will have the option of selecting the language you would like to be displayed by pressing the enter button. After approximately 3 seconds of not pressing any buttons, the oven portion will turn on.

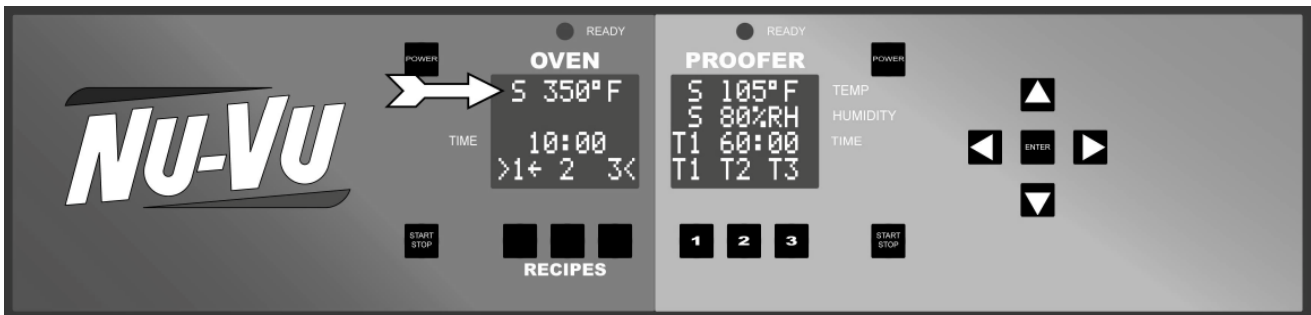

When the controller is turned on it will begin heating to the current set points (oven temp, proofer temp & proofer humidity).



When the actual oven temperature reaches the oven temperature set point the ready indicator light will remain on and an alarm will sound briefly; signifying that the oven is now ready to be loaded with product.



After the product is loaded into the oven, the operator presses the start/stop button to start the countdown timer.



When the oven timer has reached zero, an audible alarm will sound to alert the operator that the baking cycle has finished. The operator presses the start/stop button to stop the alarm and reset the countdown timer.



All of the set points can be adjusted using the buttons on the right hand side of the controller (up, down, left, right & enter).



Using the arrow buttons the operator can scroll to any of the set points.



The actual proofer temperature can be viewed by scrolling to the temp line on the proofer side of the display and the display line will toggle between the actual temp and the temp set point.



The humidity set point is displayed in % relative humidity.



The actual relative humidity can be viewed by scrolling to the humidity display line. The display line will toggle between set point and actual humidity. A separate hygrometer is not necessary to ensure that the proper humidity level is achieved. The controller uses an RH sensor to control the proofer temp and humidity level.



When the proofer temp and humidity set points are reached, the proofer ready indicator will remain on and an alarm will sound briefly; signifying that the proofer is now ready to be loaded with product.



The buttons labeled 1, 2 & 3 will allow the operator to toggle between the three timers (T1, T2 & T3).



When T1 is displayed next to the time on the proofer side of the control, pressing the start / stop button will start Timer #1.

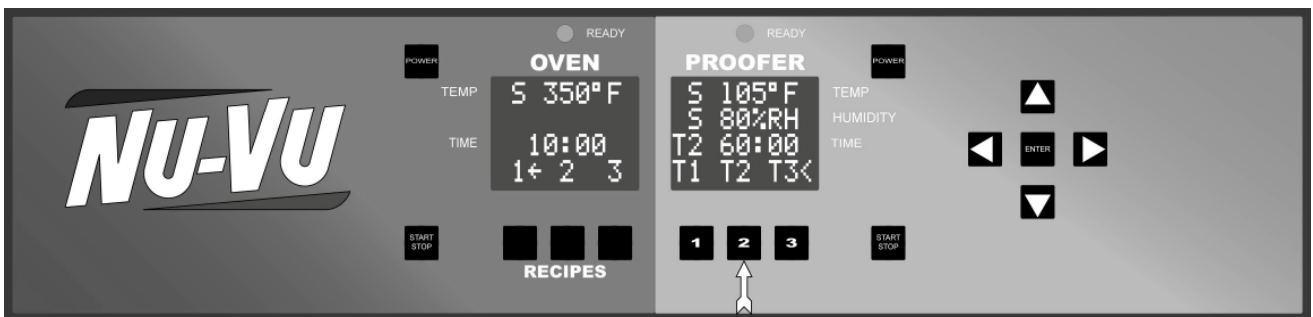

Pressing button #2 will bring up timer #2 on the display.



When T2 is displayed next to the time on the proofer side of the control, pressing the start / stop button will start Timer #2.

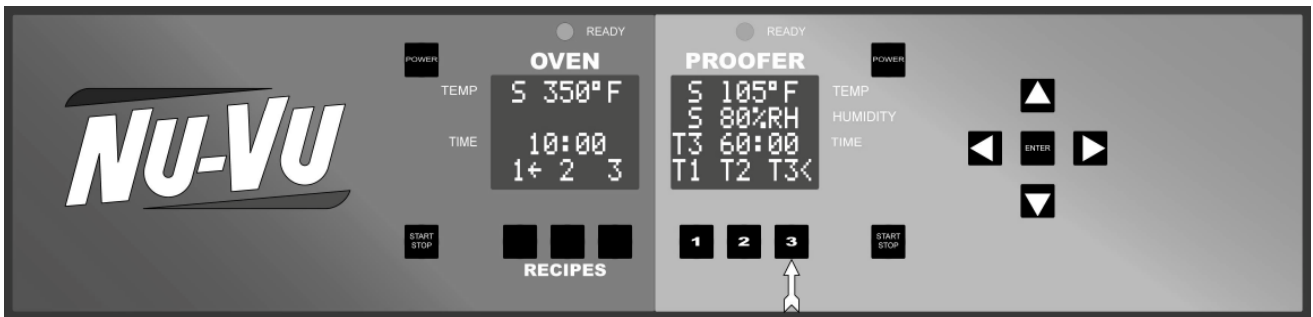

Pressing button #3 will bring up timer #3 on the display.



When T3 is displayed next to the time on the proofer side of the control, pressing the start / stop button will start Timer #3.



The operator can select a different recipe by moving the cursors to the bottom line on the proofer side of the display.



Pressing the pressing the enter button will bring up recipes 1, 2 & 3.



Pressing the pressing the enter button again will bring up recipes 4, 5 & 6.



To edit the timer set point the operator would move the cursor to line three and press the enter button.



Now that the time set point is activated, the user can change the value using the directional button.



The controller uses one-touch recipe recall using the buttons located below the oven and proofer displays. A recipe can also be saved using these buttons. To save the current settings to a recipe slot the operator would hold the button (beneath the display number) for five seconds, a beep will sound when the recipe has been saved. The save function can be locked to prevent tampering. *Note: The proofer display must show the recipe number in order to save the settings.*



An arrow will appear next to the number (on the display) of the currently loaded recipe.



The arrow buttons are used to edit all of the set points. The left and right arrows will shift the cursors between the oven and proofer sides of the display.

MAINTENANCE AND CLEANING GUIDE

MAINTENANCE:

NU-VU® equipment is designed to last for years of useful service. Careful consideration is given in selecting components for durability, performance and ease of maintenance. For example, both the Oven Motor and Proofer Motor have sealed bearings and never need to be lubricated.

While NU-VU® equipment is designed for minimum care and maintenance; certain steps are required by the user for maximum equipment life and effectiveness:

- Proper installation of the equipment.
- Correct application and usage of the equipment.
- Dry-out Procedures performed daily.
- Thorough cleaning on a regular basis.

AUTOMIST Proofer Dry-Out Procedure - -

- A. The Programmable Controller [4] has a proofer dry-function incorporated for your convenience. Upon pressing the proofer power button to turn off the proofer, you will be prompted as to weather or not to run the dry-out procedure. At this point the elements and proofer fan will be off. Pressing the proofer power button again will cancel the dry-out procedure, although it is recommended that the dry-out procedure be performed any time the proofer will be off for more than a few hours.

Use caution when wiping near the Heating Elements [9] as they may still be warm.

- B. Wipe out any standing water in the bottom of the Proofer. You will need to remove the Element Cover [60] to do this. This is also a good time to remove and clean the Humidity Nozzle [67a].
- C. Press the Enter button on the control, doing so will run the Controller's dry-out function. The proofer elements will turn on for 20 minutes to dry-out any remaining moisture, during this time the Proofer Door [42] should be left open 1 to 2 inches.
- D. Empty, clean, and replace the Drain Pan [77] beneath the Proofer.
- E. After the 20 minutes, the proofer portion of the control will automatically turn off. Re-install the Humidity Nozzle [67a] and Element Cover [60] if you have not done so already.

Oven Dry-Out Procedure - -

- A. Turn off the Oven portion of the Programmable Controller [4].
- B. Leave the Oven Door [41] open about 1 to 2 inches. The residual baking heat will dry out any moisture that may be trapped in the insulation or other components of the Oven.
- C. Leave the Oven Door slightly open (about 1 to 2 inches) while the Oven is not in use.
- D. The Cooling Fan [19] will continue to run for approximately 5 minutes after both the Oven and Proofer portions of the Programmable Controller [4] are turned off.



IMPORTANT: THESE DRY-OUT PROCEDURES MUST BE CARRIED OUT DAILY TO HELP MAINTAIN YOUR EQUIPMENT IN THE BEST POSSIBLE CONDITION. THE REMOVAL OF RESIDUAL MOISTURE HELPS PREVENT DETERIORATION OF THE INSULATION, DAMAGE TO THE PROOFER ELEMENTS, SENSORS, MOTOR AND OTHER ELECTRICAL COMPONENTS, AND EXTENDS THE USEFUL LIFETIME OF YOUR NU-VU® EQUIPMENT!

CLEANING:

Your SUB-123P should be cleaned daily and as soon as possible after a spill has occurred. It is essential to maintain a clean unit, especially if the public views the unit in your place of business. The following should be used for cleaning:

- A. The stainless steel exterior may be cleaned with any good stainless steel cleaner or polish, or with hot soapy water followed by a clear rinse if it is very soiled.
- B. The Doors can be removed for ease of cleaning by opening each Door until it is perpendicular to the face of the unit and then lifting the Door straight up. All glass should be cleaned with a glass-cleaning formula. Baked-on or excessive soiling can be removed with soap and hot water followed by a thorough rinse with fresh clean water. Severe deposits may be loosened and removed by soaking in a stronger soap and water solution.
- C. The Oven and Proofer interiors (including the Door Jamb) should be cleaned on a regular basis with mild soap and hot water followed by a thorough rinse with fresh clean water.

***WARNING:** Do not use oven cleaners in the Oven! Once in the side walls these cleaners are very difficult to remove, and may cause your oven to smoke or emit noxious fumes until they are rinsed out or burned away. You will need to completely disassemble the oven interior in order to flush out any remaining oven cleaner*

- D. The Proofer Element Cover should be removed on a regular basis when cleaning the interior of the Proofer. Clean the Element Cover with mild soap and hot water, rinse with clean fresh water, and wipe dry to prevent spotting.
- E. Proofers equipped with the AUTOMIST option should have the Water Injection Nozzle inspected and cleaned at regular intervals as determined by usage and water hardness. To clean the Water Injection Nozzle:
 - 1. Remove the Proofer Element Cover to expose the bottom of the Proofer compartment.
 - 2. Remove the nozzle by turning one quarter turn counter-clockwise after which the Nozzle can be pulled out.
 - 3. Soak all parts for 30 to 60 minutes in a small container of Lime-Away or other mild commercial mineral remover. Carefully brush and rinse all three parts.
 - 4. Install the Nozzle by aligning the flats on the Nozzle and Base, pushing the Nozzle until fully seated in the Base and turning one quarter turn clockwise.
 - 5. Replace the Element Cover.

***** CAUTION *****

NU-VU® DOES NOT RECOMMEND the use of any strong commercial or caustic product on this equipment. **DO NOT** allow any type of caustic cleaner to come into contact with any aluminum parts (such as Door Frames), the silicon rubber Door Gaskets, or any of the sealing compound in the Oven and Proofer seams and joints. These compounds may cause discoloration and degradation of these parts resulting in permanent damage. **DO NOT** use bleach or bleach compounds on any chromed parts; bleach will damage chrome plating.

NOTE:

NU-VU® has had very good results with a product called JIFFY CLEANER. For standard cleaning simply spray JIFFY on and wipe off. Heavily soiled areas may require a short period of soaking. This cleaner is available through NU-VU® (Part #51-0002) or through your local Rochester/Midland distributor or representative.

SERVICE AND REPLACEMENT GUIDE

Your SUB-123P has been designed to be serviced quickly and easily. In fact, any individual who has average mechanical ability can do the work. Our Service Department is also available to you Monday through Friday from 7:00 a.m. to 5:00 p.m. (Central Standard Time) should you find yourself with a situation or problem other than what is outlined here. Call NU-VU® at (906) 863-4401 and ask for our Service Department to order replacement parts, ask questions, or offer comments.

This *SERVICE AND REPLACEMENT GUIDE* has been prepared to cover normal service problems. If this "trouble-shooting" information does not provide a solution for your particular problem we ask that you call us for direct assistance. Calling our Service Department before calling in a repair technician can usually save you both time and unnecessary expense. We want to do everything we can to minimize your "down-time".

You may need to remove an Access Panel for servicing. **DO NOT** allow any Access Panels to drop. When work on the component is finished replace the Panel with care, making sure that all wires are properly placed and not pulled or pinched. If more than one component is being worked on try to remove only one component at a time.

The Illustrations used throughout this OWNER'S MANUAL are numbered in their lower left-hand corners. A complete listing of these Illustrations along with their page numbers can be found at the beginning of this manual on page v.

A REPLACEMENT PARTS LIST can be found starting on page 28. These parts are listed by Reference Number. The part Reference Numbers are circled ○ in the illustrations and bracketed [] in the text. Please note that some of the parts listed are not replaceable except as part of another assembly, but are listed for reference and identification only.

Wiring schematics are included at the end of this OWNER'S MANUAL for reference only. Please contact our Service Department at (906) 863-4401, for more detailed and current information.

*** NOTICE ***

NATIONAL SANITATION FOUNDATION (NSF) GUIDELINES REQUIRE THAT ALL INTERIOR PARTS BE REMOVABLE WITHOUT THE USE OF TOOLS. THIS EQUIPMENT HAS BEEN FACTORY ASSEMBLED TO SAFELY ACCOMMODATE ROUGH HANDLING THROUGH SHIPMENT AND ORIGINAL INSTALLATION. AFTER ANY MAINTENANCE, CLEANING OR REQUIRED SERVICE WORK THE INTERIOR SHEET-METAL PARTS SHOULD BE REASSEMBLED AND FASTENED HAND-TIGHT ONLY, BUT STILL REMAIN TIGHT ENOUGH TO PREVENT ANY RATTLE OR MOVEMENT OF PARTS.

DOOR LATCH, How To Adjust:

Determine if the Oven Door [41] or Proofer Door [42] is fitting too loose (it will leak moisture and heated air past the Gasket) or too tight (it will not close properly, or will "pop" open unexpectedly). If it is too loose the Door Latch [44] must be adjusted OUT (away from the unit); if it is too tight the Door Latch must be adjusted IN (towards the unit). Please proceed as follows:

- A. Loosen the two acorn nuts inside the Latch Cover [45] with a 3/8" box wrench. Pull the Latch Cover straight out from the Door to remove it, and then remove the acorn nuts.
- B. Open the Door and take careful notice of the adjustment plate position against the body of the Door Latch.
- C. Hold the adjustment plate against the body of the Door Latch with one hand while you loosen the three mounting screws with the other hand. Back the screws out approximately three full turns.
- D. CAREFULLY move the Door Latch body IN or OUT under the adjustment plate *one notch at a time*. Make sure the Door Latch stays straight up and down, and tighten the mounting screws. Test the Door for proper closing and sealing (refer to the *DOOR TEST PROCEDURE*).
- E. Repeat steps "C" and "D" if you are not satisfied with the Door adjustment. If the Door tests as satisfactory make sure the three mounting screws are tightened securely.
- F. Install the acorn nuts on the ends of the top and bottom Door Latch screws. Turn the nuts on all the way until they just contact the back side of the latch bracket, then loosen them by 1½ to 2 full turns. Install the Latch Cover and tighten the acorn nuts lightly to hold the Latch Cover in place.

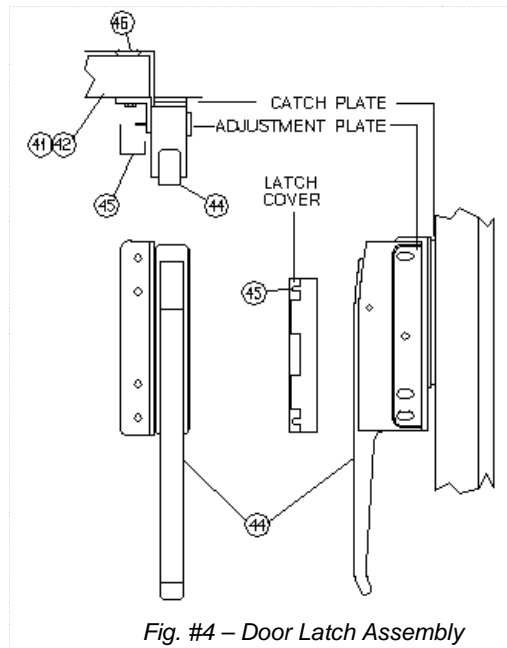

Fig. #4 - Door Latch Assembly

DOOR TEST PROCEDURE:

- A. Cut one or two strips of paper approximately 1" wide and 8" to 10" long.
- B. Open the Door slightly, insert a strip of paper between the Gasket [46] and Door Jamb and close the Door.
- C. Slowly pull the paper strip out. You should feel some resistance as you pull the strip from between the Gasket and Door Jamb of a properly adjusted Door. Test the fit at regular 2" to 3" intervals around the entire Door.
 1. If you feel NO resistance at a particular spot the Door is too loose, you have found a weak or damaged spot in the Door Gasket or the Door Jamb has been bent in.
 2. If you feel HEAVY resistance at a particular spot the Door is too tight or the Door Jamb has been bent out.

DOOR GASKET, How To Replace:

Follow these instructions to correctly and easily replace your Door Gasket with minimal problems. If you have any problems or questions please call the NU-VU® Service Department at (906) 863-4401 Monday through Friday from 7:00 a.m. until 5:00 p.m. for assistance.

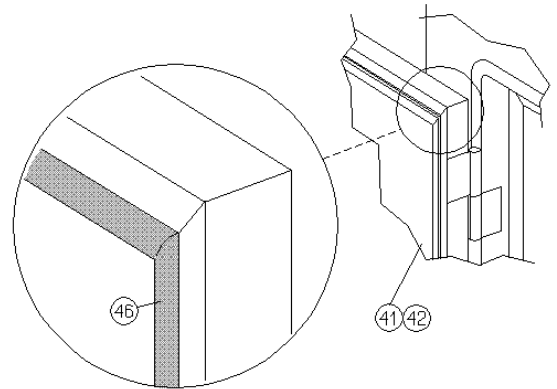

Fig. #5 – Door Gasket

Replacing the Oven Door Gasket - -

- A. Remove all pieces of the old Gasket. Thoroughly clean the Door frame in the area of the new gasket installation. Remove any old sealant and any baked-on deposits.
- B. Replacement Gasket for the Oven Door is supplied to you as a single length of high-temperature material. This Gasket must be cut to lengths that slightly overlap the sides of the Door frame.
- C. Put a small amount of soap water into and around the slot that the new Gasket will fit into (a small trigger spray bottle works well). This step is optional but will help in the installation.
- D. Position the new Gasket over the slot, allowing the ends to extend past the end of the slot. Press the mounting flange down into the slot on the Door frame. Use a roller tool to force the mounting flange into the slot by working the tool back and forth along the Gasket. Make sure the Gasket mounting flange is completely fitted into the slot and that the Gasket is free to slide back and forth in the slot.

IMPORTANT: DO NOT STRETCH OR PULL ON THE GASKET DURING THE INSTALLATION PROCESS. THIS WILL LATER CAUSE THE TRIMMED CORNERS TO SEPARATE AND PULL APART!

- E. Use a sharp knife or a single-edged razor blade to cut the ends of the Gasket at a 45° angle (you can use the mitered corner joint on the Door as an angle guide). Cut the Gasket about 1/4" longer than the required length and work the excess back into the slot. This extra Gasket will help to create a nice tight corner joint, and allows for any follow-up trimming that may be necessary.
- F. Work your way around the entire Door (or the section of the Door having the Gasket replaced). Make sure the Gasket is just tight into the corners. A bulging joint or pucker along the Gasket indicates a Gasket section that is cut too long. Joints that pull apart indicate that one or more gasket sections are cut too short.

IMPORTANT: MAKE SURE THAT THE GASKET AND DOOR FRAME ARE BOTH COMPLETELY CLEAN AND DRY BEFORE APPLYING ANY SEALANT!

- G. Seal the corner joints after the entire Gasket is properly fitted. Pull the joints apart only enough to put sealant on all of the *cut edges only*. Allow the Gasket joint to come together. Smooth out any excess sealant to form a smooth surface on the face of the Gasket. Add more sealant to any spots as necessary and smooth them down.

- H. A quality sealant will be dry to the touch and tack-free in one to two hours after application. However, it will not be completely cured until six to eight hours later. We recommend that you wait until after your sealant is completely cured before using your Oven.



WARNING: SOME SEALANTS GIVE OFF ACIDIC FUMES AS THEY CURE. THESE FUMES MAY CAUSE IRRITATION TO THE EYES AND/OR NASAL PASSAGES. USE CAUTION WHEN OPENING YOUR UNIT AFTER WAITING FOR ANY FRESH SEALANT TO SET UP AND CURE!

Replacing the Proofer Door Gasket - -

- A. Remove all pieces of the old Gasket. Thoroughly clean the Door frame in preparation for the new installation. Remove any old sealant, bits of Gasket and baked-on deposits.
- B. The replacement Proofer Door Gasket is supplied as a single formed piece of low-temperature material. This material is not suited for use in a high-temperature application, and should never be used on an Oven Door.
- C. Place the formed Gasket over the slot in the face of the Door frame and press it firmly into place. A small roller tool will aid in fully seating the Gasket in the mounting slot.
- D. The replacement Gasket requires nothing further. You may begin using your Proofer as soon as the Gasket has been installed.

NU-VU[®] EQUIPMENT WARRANTY

NU-VU[®] products are warranted against defects in workmanship and materials from the original date of shipment only. NU-VU[®] does not warrant against any damage that may occur during shipment or storage of the equipment. Any claim for such damage must be filed against the carrier or storage company. No other express warranty, written or oral, applies. No person is authorized to give any other warranty or assume any other liability on behalf of NU-VU[®], except by written statement from an officer of NU-VU[®].

Your NU-VU[®] equipment warranty is limited to the following time periods for the original owner only:

	<u>PARTS</u>	<u>LABOR</u>
Inside the United States	24 Months	12 Months
All areas outside the United States	12 Months	12 Months

These time limits will apply in all cases unless prior arrangements have been made and agreed to in writing.

The NU-VU[®] equipment warranty is composed of the following:

PARTS:

This limited warranty covers certain electrical, electronic and mechanical parts for the time periods shown above with the exception of those items detailed under Warranty Limitations. Customers who maintain an open account may purchase against their account. MasterCard, Visa and American Express credit cards are also accepted.

The return of defective parts is required. The return of a defective part or component must be made prior to the issuance of a credit on an open account. If a part that is returned tests satisfactory in the NU-VU[®] factory or at an authorized NU-VU[®] dealer or service agency, NU-VU[®] may withhold issuing credit. Replacement parts will be warranted for a period of *ninety (90) days* provided they are installed and used in a manner authorized by NU-VU[®].

LABOR:

We require that you call our NU-VU[®] Service Department at (906) 863-4401 for service authorization BEFORE you call any service agency if you wish to claim a labor expense under this warranty. We may be able to solve your problem over the telephone, or we will schedule a warranty service call by a reliable service agency in your area.

This warranty covers the replacement and installation of parts and components which are included under **PARTS** for the time period listed above. This coverage is limited to the normal mileage allowance for a maximum travel radius of up to fifty (50) miles, and the normal labor rate times the allowable hours for performing the work as set forth in the following listing:

STANDARD TIME ALLOWANCES FOR WARRANTY REPLACEMENTS

<u>Change performed</u>	<u>Change time</u>	<u>Test time</u>	<u>Total time</u>
Oven Heating Element	1 hr.	½ hr.	1½ hr.
Oven Motor/Rebalance Fan	1 hr.	½ hr.	1½ hr.
Programmable Controller	½ hr.	½ hr.	1 hr.
Control Sensor	½ hr.	½ hr.	1 hr.
Proofer Heating Element	½ hr.	½ hr.	1 hr.
Contactors	½ hr.	5 min.	½ hr.
Proofer Motor	½ hr.	5 min.	½ hr.

These times are based on servicing a unit that has been installed with allowance made for Access Panels on the unit. If the unit is built into a wall that makes servicing very difficult or impossible without removing part of the counter, wall, trim, etc., the extra time for gaining access shall be charged to the owner of the unit. NU-VU® has determined that the listed times, which are based on the period necessary for a trained service person to perform the work noted, are fair and reasonable. If a problem is not diagnosed within a half-hour, the service person must contact the NU-VU® Service Department via telephone. Additional time for problem solving will not be allowed unless this procedure is followed. An appointment for servicing a unit should be set up since time will not be allowed for waiting to service a unit. Unless the service person justifies extra time for performing the work noted, charges for work performed by the service person in excess of the allowed time shall either be billed to the owner of the equipment or denied.



IMPORTANT: NU-VU WILL NOT PAY FOR ANY SERVICE CALLS AS WARRANTY WORK IF A NU-VU® AUTHORIZED SERVICE AGENCY DETERMINES THAT YOUR EQUIPMENT IS SET UP AND OPERATING PROPERLY!

WARRANTY LIMITATIONS:

NU-VU® will pay for parts and labor under warranty if there is a defective component, but not for:

- Normal operational wear and tear on the following parts -
 - ┌ Light bulbs
 - ┌ Door gaskets
 - ┌ Door handles and catches
 - ┌ Fuses
- Damage attributable to customer abuse, including -
 - ┌ Proofer water pan allowed to run dry and burn.
 - ┌ Proofer fan motor damaged from not following outlined Dry-Out Procedure.
 - ┌ Lack of regular cleaning or maintenance.
- Power supply problems, including -
 - ┌ Insufficient or incorrect voltage.
 - ┌ Damage to electrical components caused by a power surge or spike.
 - ┌ Incorrect installation (i.e., equipment not supplied with separate neutral or ground as required, or incorrect location of high-voltage power leg for 240-volt 3-phase units).
 - ┌ Damage to electrical components resulting from use of an incorrect power supply cord or circuit breaker.
- Operational problems resulting from customer’s failure to follow established procedures outlined in the Owner’s Manual.
- A service call if nothing is found to be wrong (any returned parts work as per spec when tested).
- Recalibration of temperature and humidity controls (all controls are carefully calibrated and tested at our facility before shipment).
- Any equipment moved from the place of original installation unless NU-VU® agrees in writing to continue the warranty after the relocation.
- Ongoing operational adjustments due to changing environmental conditions or normal wear and tear.
- Any overtime charges. NU-VU® will pay straight time only for any work performed on NU-VU® equipment.

Products must be installed and maintained in accordance with NU-VU[®] instructions. Users are responsible for the suitability of the products to their application. There is no warranty against damage resulting from accident, abuse, alteration, misapplication, inadequate storage prior to installation, or improper specification or other operating conditions beyond our immediate control. Claims against carrier damage in transit must be filed by the buyer; therefore, the buyer **must inspect** the product immediately upon receipt.

***THIS WARRANTY DOES NOT COVER ADJUSTMENTS
DUE TO NORMAL ON-GOING USE OF THE UNIT!!!***

PARTS RETURN PROCEDURE AND CONDITIONS:

The following procedure shall be followed for the return of parts to the factory for credit consideration:

- All parts received by NU-VU[®] must have a completed RETURN AUTHORIZATION FORM as supplied by NU-VU[®] with the replacement part.
- Package all return parts securely so that in-transit damage cannot occur.
- Prepay shipment. Any parts returned collect will be refused by our receiving department. Credit will be considered on proper returns only.
- As soon as parts are tested and confirmed to be defective credit will be issued against them.
- If the engineering test shows the component is not defective and is in good working condition it may be returned to you along with your request for payment.

Please use this space to record the Model Number and complete 12-digit Serial Number from the nameplate on the side of your NU-VU[®] equipment. You will need both of these numbers if you ever need to contact our Service Department concerning adjustments, replacement parts or other service.

Model Number: S U B - 1 2 3 P

Serial Number: _____

REPLACEMENT PARTS LIST

(SUB-123P)

Reference #	Description	Replacement Part #
ELECTRICAL COMPONENTS - -		
1	Power Terminal Block	50-0237
2	Ground Lug	50-1329
3	Contactor:	
	120-volt coil, 40-amp (US).....	66-2013
4	Programmable Controller Assembly	112-9153
5	Oven Temperature Sensor	252-3001
6	Oven Heating Element:	
	208-volt, 2000-watt	251-1005
	240-volt, 2000-watt	251-1002
7	Oven Motor Assembly.....	250-1002
8	Proofer Sensor	66-1146
9	Proofer Heat Element:	
	120-volt 600-watt (Automist)	60-0001-1-B
11	Proofer Motor Assembly:	
	Automist.	250-2010
12	Control Transformer (24 VAC output)	66-9505
15	Oven Door Micro Switch	252-2004
16	Alarm	252-1022
17	Thermal Overload Safety (425°F).....	66-1114
18	Manual Reset Fuse (20 Amp).....	66-1097
19	Cooling Fan.....	250-3001
20	Light Fixture:	
	Socket	50-1020
	Bulb:	
	120-volt, 40-watt (US)	50-0695
	Light fixture kit Oven (Socket, Globe, and Gasket)	252-7004
	Light fixture kit Proofer (Socket, Globe, and Gasket)	252-7006
21	Water Solenoid Valve (Automist only).....	50-0308-1
DOOR COMPONENTS - -		
41	Oven Door (without Latch):	
	Hinged Left	112-9159
	Hinged Right	112-9151
42	Proofer Door (without hardware).....	21-1950
43	Proofer Door Hinge:	
	Left side	254-3011
	Right side	254-3012
44	Latch/Catch Assembly:	
	Proofer.....	254-2025
	Oven	254-2026
46	Gasket:	
	Oven Door.....	254-1001
	Proofer Door	70-0358-A

OVEN INTERIOR COMPONENTS - -

50	Oven Wall Assembly (Right).....	112-9067
51	Oven Wall Assembly (Left).....	112-9066
52	Oven Element / Fan Cover.....	112-0013-B
53	Wire Fan Guard.....	112-0275

PROOFER INTERIOR COMPONENTS - -

60	Proofer Element / Fan Cover Automist	112-9027
61	Proofer Wall Assembly (Right)	112-9023
62	Proofer Wall Assembly (Left)	112-9024
65	Wire Shelf	112-0059-B
67a	Quick-change Humidity Injection Nozzle	31-0454
67b	Quick-change Humidity Injection Nozzle Base	31-0453

GENERAL EXTERIOR COMPONENTS - -

71	Outside Top	112-0075-B
75	Caster	50-0058
76	Water Inlet Bulkhead (Automist only)	31-0058
77	Drain Pan	50-0547
78	Side Panel	112-0066-1-A
79	Water Filter Housing (Automist only).....	50-1401
80	Water filter Cartridge (Automist only).....	50-1402

AMP/TYCO ELECTRONICS
 P/N 1-480710-0
 Universal MATE-N-LOK

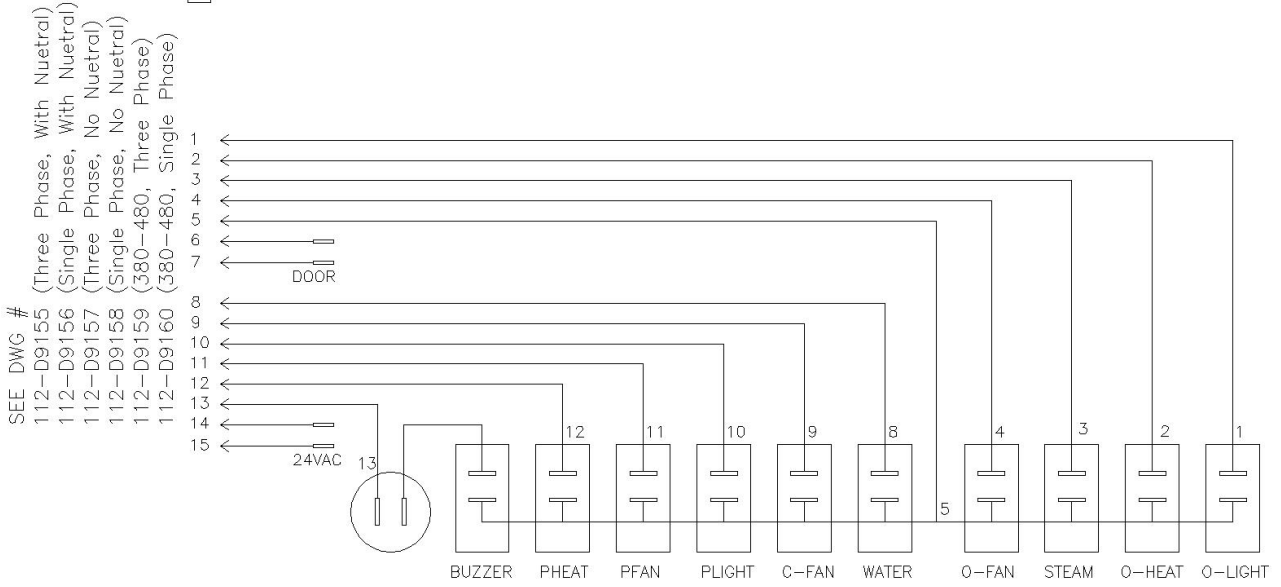

NUVU	NU-VU Food Service Systems 5600 13th STREET MENOMINEE, MICHIGAN 49856	REV. A.4	DESCRIPTION	CHANGED BY	DRAWN BY: KM	VOLTAGE: ALL	MODEL #: SUB-123P / SUB-123PI
			ADDED ADDITIONAL	KM	CHECKED:	PHASE: SINGLE or THREE	CUSTOMER
			REFERENCE NOTES	DATE	DATE: 01-31-2008	WATTAGE:	
				9-3-08	BOM FILE #	CONTROLS: PROGRAMABLE	DWG. NO. 112-D9154

