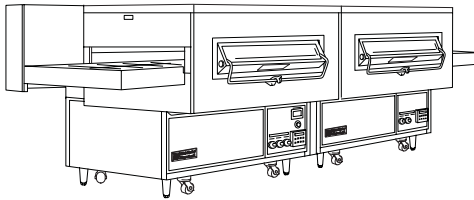
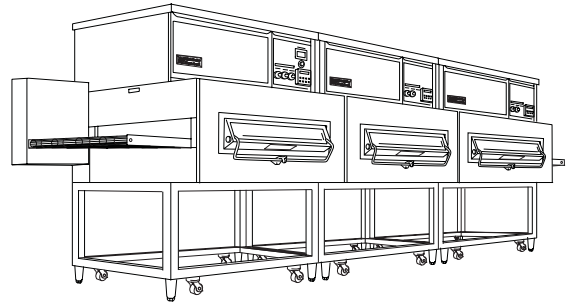


# *owner's operating & installation manual*

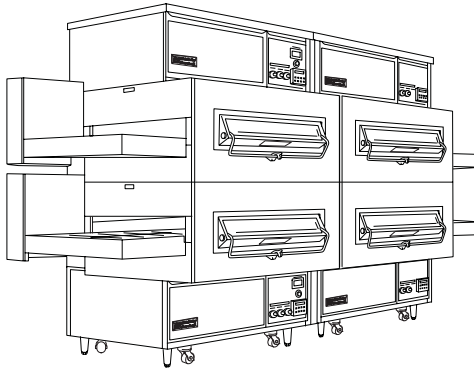
## **SERIES PS360/PS360WB TANDEM GAS OVEN MODELS**



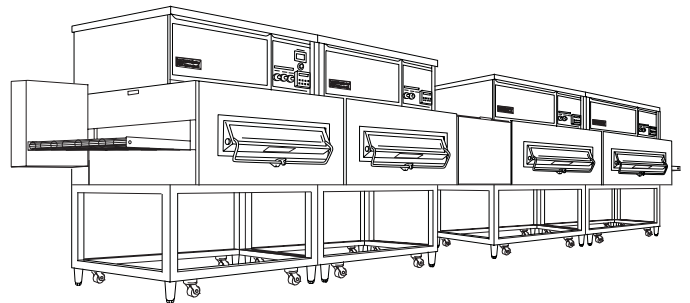
PS360/PS360WB Tandem Oven



PS360/PS360WB Tri Tandem Oven



PS360/PS360WB Double Tandem Oven



PS360/PS360WB Quad Tandem Oven

**NOTICE:**

**This Operating and Installation Manual should be given to the user. The operator of the oven should be familiar with the functions and operation of the oven.**

**This manual must be kept in a prominent, easily reachable location near the oven.**

**The oven has a combustion system suitable for use with all natural gases and can be converted by a qualified service agent for use with liquified gas.**

**It is suggested to obtain a service contract with a manufacturer's certified service agent.**

**WARNING**

**POST, IN A PROMINENT LOCATION, THE EMERGENCY TELEPHONE NUMBER OF YOUR LOCAL GAS SUPPLIER AND INSTRUCTIONS TO BE FOLLOWED IN THE EVENT YOU SMELL GAS.**

Instructions to be followed in the event the user smells gas shall be obtained by consulting the local gas supplier. If the smell of gas is detected, immediately call the emergency phone number of your local Gas Company. They will have personnel and provisions available to correct the problem.

**FOR YOUR SAFETY**

**Do not store or use gasoline or other flammable vapors or liquids in the vicinity of this or any other appliance.**

**WARNING:**

**Improper installation, adjustment, alteration, service or maintenance can cause property damage, injury or death. Read the installation, operating and maintenance instructions thoroughly before installing or servicing this equipment.**

**NOTICE**

**CONTACT YOUR LOCAL SERVICE COMPANY TO PERFORM MAINTENANCE AND REPAIRS. A SERVICE AGENT DIRECTORY IS SUPPLIED IN YOUR INSTALLATION KIT.**

**NOTICE**

Using any parts other than genuine Middleby Marshall factory manufactured parts relieves the manufacturer of all warranty and liability.

**NOTICE**

Middleby Marshall (Manufacturer) reserves the right to change specifications at any time.

**NOTICE**

The equipment warranty is not valid unless the oven is installed, started and demonstrated under the supervision of a factory certified installer.

**Retain This Manual For Future Reference**

---

Middleby Marshall Inc. • 1400 Toastmaster Drive • Elgin, IL 60120 • USA • (847) 741-3300 • FAX (847) 741-4406

***Middleby Corporation Service Hotline 1-800-238-8444***

***www.middleby.com***

**MIDDLEBY MARSHALL INC.  
NO QUIBBLE LIMITED WARRANTY  
(U.S.A. ONLY)**

MIDDLEBY MARSHALL, HEREINAFTER REFERRED TO AS THE SELLER, WARRANTS EQUIPMENT MANUFACTURED BY IT TO BE FREE FROM DEFECTS IN MATERIAL AND WORKMANSHIP FOR WHICH IT IS RESPONSIBLE. THE SELLER'S OBLIGATION UNDER THIS WARRANTY SHALL BE LIMITED TO REPLACING OR REPAIRING AT SELLER'S OPTION, WITHOUT CHARGE, ANY PART FOUND TO BE DEFECTIVE AND ANY LABOR AND MATERIAL EXPENSE INCURRED BY SELLER IN REPAIRING OR REPLACING SUCH PART, SUCH WARRANTY SHALL BE LIMITED TO THE ORIGINAL PURCHASER ONLY AND SHALL BE EFFECTIVE FOR A PERIOD OF ONE YEAR FROM DATE OF ORIGINAL INSTALLATION, OR 18 MONTHS FROM DATE OF SHIPMENT, WHICHEVER IS EARLIER; PROVIDED THAT TERMS OF PAYMENT HAVE BEEN FULLY MET.

This warranty is valid only if the equipment is installed, started and demonstrated under the supervision of a factory certified installer.

Normal maintenance functions, including lubrication, cleaning or customer abuse are not covered by this no quibble warranty.

Seller shall be responsible only for repairs or replacements of defective parts performed by Seller's authorized service personnel. Authorized service agencies are located in principal cities throughout the contiguous United States, Alaska and Hawaii. This warranty is valid in the 50 United States and is void elsewhere unless the product is purchased through Middleby International with warranty included.

**The foregoing warranty is exclusive and in lieu of all other warranties, expressed or implied. There are no implied warranties of merchantability or of fitness for a particular purpose.**

The foregoing warranty shall be Seller's sole and exclusive obligation and Buyer's sole and exclusive remedy for any action including breach of contract or negligence. In no event shall Seller be liable for a sum in excess of the purchase price of the item. Seller shall not be liable for any prospective or lost profits of Buyer.

**MIDDLEBY MARSHALL INC.  
OVEN LIMITED WARRANTY  
(Non U.S.A.)**

The seller warrants equipment manufactured by it to be free from defects in material and workmanship for which it is responsible. The Seller's obligation under this warranty shall be limited to replacing or repairing at Seller's option, without charge, F.O.B. Seller's factory, any part found to be defective and any labor and material expense incurred by Seller in repairing or replacing such part, such warranty to be limited to a period of one year from date of original installation or 15 months from date of shipment from Seller's factory, whichever is earlier, provided that terms of payment have been fully met. All labor shall be performed during regular working hours. Overtime premium will be charged to the Buyer.

**This warranty is not valid unless equipment is installed, started, and demonstrated under the supervision of a factory certified installer.**

Normal maintenance functions, including lubrication, adjustment of airflow, thermostats, door mechanisms, microswitches, burners and pilot burners and replacement of light bulbs, fuses and indicating lights, are not covered by warranty.

Any repairs or replacements of defective parts shall be performed by Seller's authorized service personnel. Seller shall not be responsible for any costs incurred if the work is performed by other than Seller's authorized service personnel.

When returning any part under warranty, the part must be intact and complete, without evidence of misuse or abuse, freight prepaid.

Seller shall not be liable for consequential damages of any kind which occur during the course of installation of equipment, or which result from the use or misuse by Buyer, its employees or others of the equipment supplied hereunder, and Buyer's sole and exclusive remedy against Seller for any breach of the foregoing warranty or otherwise shall be for the repair or replacement of the equipment or parts thereof affected by such breach.

The foregoing warranty shall be valid and binding upon Seller if and only if Buyer loads, operates and maintains the equipment supplied hereunder in accordance with the instruction manual provided to Buyer. Seller does not guarantee the process of manufacture by Buyer or the quality of product to be produced by the equipment supplied hereunder and Seller shall not be liable for any prospective or lost profits of Buyer.

**THE FOREGOING WARRANTY IS EXCLUSIVE AND IN LIEU OF ALL OTHER EXPRESS AND IMPLIED WARRANTIES WHATSOEVER. SPECIFICALLY THERE ARE NO IMPLIED WARRANTIES OF MERCHANTABILITY OR OF FITNESS FOR A PARTICULAR PURPOSE.**

The foregoing shall be Seller's sole and exclusive obligation and Buyer's sole and exclusive remedy for any action, whether in breach of contract or negligence. In no event shall seller be liable for a sum in excess of the purchase price of the item.

# TABLE OF CONTENTS

	<i>page</i>		<i>page</i>
<b>SECTION1-DESCRIPTION .....</b>	<b>1-1</b>	<b>SECTION3-OPERATION .....</b>	<b>3-1</b>
I. OVEN SPECIFICATIONS .....	1-1	I. LOCATION AND DESCRIPTION OF CONTROLS .....	3-1
A. Physical Specifications .....	1-1	A. BLOWER Switch .....	3-1
B. General Specifications .....	1-1	B. HEAT Switch .....	3-1
C. Electrical Specifications .....	1-1	C. CONVEYOR Switch .....	3-1
D. Gas Orifice and Pressure Specifications .....	1-1	D. Digital Temperature Controller .....	3-1
II. OVEN USES .....	1-2	E. Conveyor Speed Display .....	3-1
III. OVEN COMPONENTS .....	1-2	F. Conveyor Speed Adjustment Knob .....	3-1
A. Conveyor Drive Motor .....	1-2	G. Conveyor Speed Controller .....	3-1
B. Air Fingers .....	1-2	H. Machinery Cpt. Access Panel Safety Switch ..	3-1
C. Conveyor .....	1-2	II. NORMAL OPERATION, STEP-BY-STEP .....	3-2
D. Window .....	1-2	A. Daily Startup Procedures .....	3-2
E. Oven Data Plate .....	1-2	B. Daily Shutdown Procedures .....	3-2
F. Crumb Pans .....	1-2	III. QUICK REFERENCE: BAKE TIME .....	3-3
G. Control Panel .....	1-2	IV. QUICK REFERENCE: DIGITAL TEMP CONTROL .....	3-3
H. Machinery Compartment Access Panel .....	1-2	V. QUICK REFERENCE: TROUBLESHOOTING .....	3-4
I. End Panels .....	1-2		
J. Conveyor End Stop .....	1-2	<b>SECTION4-MAINTENANCE .....</b>	<b>4-1</b>
K. Conveyor Extension Covers .....	1-2	I. MAINTENANCE - DAILY .....	4-2
L. Gas Burner .....	1-2	II. MAINTENANCE - MONTHLY .....	4-3
M. Blowers .....	1-2	III. MAINTENANCE - EVERY 3 MONTHS .....	4-4
N. Cooling Fans .....	1-2	IV. MAINTENANCE - EVERY 6 MONTHS .....	4-4
<b>SECTION2-INSTALLATION .....</b>	<b>2-1</b>	<b>SECTION5-ELECTRICAL SCHEMATICS .....</b>	<b>4-1</b>
I. INSTALLATION KIT .....	2-2	I. WIRING DIAGRAM, PS360/PS360WB	
II. TRANSITION CHAMBER COMPONENTS .....	2-2	Tandem & Double Tandem Ovens .....	4-1
III. VENTILATION SYSTEM .....	2-3	II. WIRING DIAGRAM, PS360/PS360WB	
A. Requirements .....	2-3	Tri Tandem & Quad Tandem Ovens .....	4-2
B. Recommendations .....	2-3		
C. Other Ventilation Concerns .....	2-3		
IV. THERMOCOUPLE INSTALLATION .....	2-4		
V. ASSEMBLY .....	2-5		
A. Oven Stand .....	2-5		
B. Joining the Oven Bodies .....	2-5		
C. Installing the Center Transition .....	2-7		
D. Installing the Conveyor Frame and Belt .....	2-9		
VI. ELECTRICAL SUPPLY .....	2-12		
VII. GAS SUPPLY .....	2-13		
A. Connection .....	2-13		
B. Gas Conversion .....	2-14		

# SECTION 1 DESCRIPTION

## I. OVEN SPECIFICATIONS

### A. PHYSICAL SPECIFICATIONS

	<i>Tandem</i>		<i>Double Tandem</i>		<i>Tri Tandem</i>		<i>Quad Tandem</i>	
	<i>PS360</i>	<i>PS360WB</i>	<i>PS360</i>	<i>PS360WB</i>	<i>PS360</i>	<i>PS360WB</i>	<i>PS360</i>	<i>PS360WB</i>
<b>Dimensions:</b>								
Overall Height (inc. top)	45-1/2" 1156mm	45-1/2" 1156mm	81-1/2" 2070mm	81-1/2" 2070mm	64-1/2" 1638mm	64-1/2" 1638mm	64-1/2" 1638mm	64-1/2" 1638mm
Overall Depth (inc. motor shroud and window)	52" 1321mm	60" 1524mm	52" 1321mm	60" 1524mm	52" 1321mm	60" 1524mm	52" 1321mm	60" 1524mm
Overall Depth (inc. motor shroud - no window)	49" 1245mm	57" 1448mm	49" 1245mm	57" 1448mm	49" 1245mm	57" 1448mm	49" 1245mm	57" 1448mm
Overall Length	144-1/2" 3670mm	144-1/2" 3670mm	144-1/2" 3670mm	144-1/2" 3670mm	199" 5055mm	199" 5055mm	273-1/2" 6947mm	273-1/2" 6947mm
Conveyor Width	32" 813mm	40" 1016mm	32" 813mm	40" 1016mm	32" 813mm	40" 1016mm	32" 813mm	40" 1016mm

### Recommended Minimum

#### Clearances:

Rear of Oven (inc. motor shroud) to Wall	1" 25mm	1" 25mm	1" 25mm	1" 25mm	1" 25mm	1" 25mm	1" 25mm	1" 25mm
Conveyor Extension to Wall (both ends)	0" 0mm	0" 0mm	0" 0mm	0" 0mm	0" 0mm	0" 0mm	0" 0mm	0" 0mm

### B. GENERAL SPECIFICATIONS (per oven section)

	<i>PS360</i>	<i>PS360WB</i>
Weight	1350 lbs. (612kg)	1400 lbs. (634kg)
Shipping Weight	1675 lbs. (760 kg)	1750 lbs. (780kg)
Shipping Cube	Approx. 104.5 ft <sup>3</sup> (3.0 m <sup>3</sup> )	Approx. 122 ft. <sup>3</sup> (3.5m <sup>3</sup> )
Rated Heat Input	135,000 BTU (34,020 kcal, 40 kW/hr)	170,000 BTU (42,840 kcal, 50 kW/hr)
Maximum Operating Temperature	550°F (288°C)	
Air Blowers	Two blowers at 1550 ft. <sup>3</sup> /min. (43.9m <sup>3</sup> /min.) at 1700 rpm 0.88" (2.2cm) Water Static Pressure	
Average Air Jet Velocity	2600 ft./min. (1320cm/sec.)	
Warmup Time	15 min.	
Flue Vent	1.08" (27mm) D x 3" (76mm) W	
Exhaust Flow	80 ft. <sup>3</sup> /min. (2.1 m <sup>3</sup> /min.)	

### C. ELECTRICAL SPECIFICATIONS (per oven section)

<i>Main Blower Voltage</i>	<i>Control Circuit Voltage</i>	<i>Phase</i>	<i>Freq</i>	<i>Current Draw</i>	<i>Poles</i>	<i>Wires</i>
208-240V	120V	1 Ph	50/60Hz	8A	3 Pole	4 Wire (2 hot, 1 neut, 1 gd)
190/200/208/220/380V (export)	110V (transformer)	1 Ph	50Hz	8A	2 Pole	3 Wire (2 hot, 1 gd)

### D. GAS ORIFICE AND PRESSURE SPECIFICATIONS (per oven section)

<i>Gas Type</i>	<i>Main Orifice I.D. (PS360)</i>	<i>Main Orifice I.D. (PS360WB)</i>	<i>Pilot Orifice I.D.</i>	<i>Bypass Orifice I.D.</i>	<i>Supply (Inlet) Pressure</i>	<i>Orifice (Manifold) Pressure</i>
Natural	0.219" (5.56mm)	0.250" (6.35mm)	0.028" (0.71mm)	0.065"/#53 drill (1.65mm)	6-12" W.C. (14.9-29.9mbar)	3.5" W.C. (8.7mbar)
Propane	0.134" (3.40mm)	0.152" (3.86mm)	0.018" (0.46mm)	0.034"/#62 drill (0.86mm)	11-14" W.C. (27.4-34.9mbar)	10" W.C. (24.9mbar)

## SECTION 1 DESCRIPTION

### II. OVEN USES

PS360/PS360WB Tandem Ovens can be used to bake and/or cook a wide variety of food products, such as pizza, pizza-type products, cookies, sandwiches and others.

### III. OVEN COMPONENTS

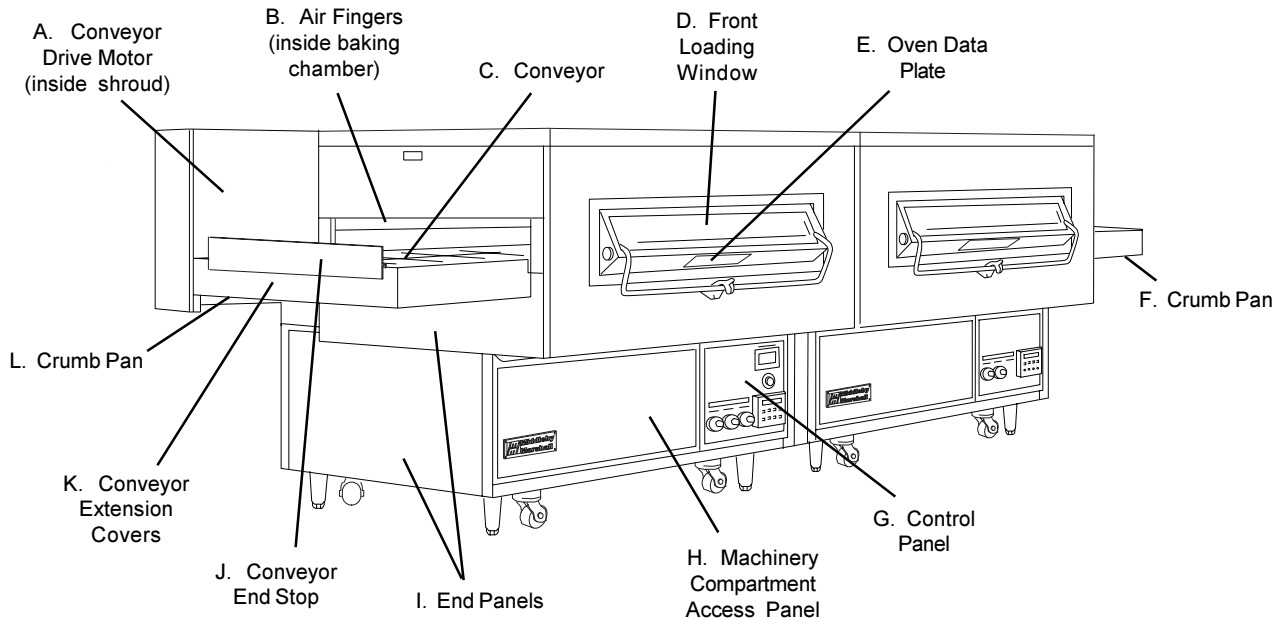


Figure 1-1 - Oven Components

- A. Conveyor Drive Motor:** Moves the conveyor.
  - B. Air Fingers:** Project streams of hot air onto the food product.
  - C. Conveyor:** Moves the food product through the oven.
  - D. Window (on ovens so equipped):** Allows the user to see and access food products inside the baking chamber.
  - E. Oven Data Plate:** Provides specifications for the oven that affect installation and operation. Refer to Section 2, Installation, for details.
  - F. Crumb Pans:** Catch crumbs and other material that drop through the conveyor belt. One crumb pan is located at each end of the conveyor.
  - G. Control Panel:** Location of the operating controls for the oven. Refer to Section 3, Operation, for details.
  - H. Machinery Compartment Access Panel:** Allows access to the oven's interior components. No user-servicable parts are located in the machinery compartment.
  - I. End Panels:** Allow access to the oven's interior components. No user-servicable parts are located inside the end panels.
  - J. Conveyor End Stop (not present on ovens with heavy-duty conveyor):** Prevents food products from falling off the end of the moving conveyor.
  - K. Conveyor Extension Covers (not present on ovens with heavy-duty conveyor):** Cover the ends of the conveyor frame. One cover is located at each end of the conveyor.
- Not Shown:*
- L. Gas Burner:** Heats air, which is then projected to the air fingers by the blowers. The burner is turned on and off according to the settings on the Digital Temperature Controller (located on the Control Panel).
  - M. Blowers:** Fans that project hot air from the burner to the air fingers.
  - N. Cooling Fans:** Cool the interior of the oven to protect the components.

## SECTION 2 INSTALLATION

### WARNING

Do not obstruct the flow of combustion and ventilation air to and from your oven. There must be no obstructions around or underneath the oven.

### CAUTION

For additional installation information, refer to the *PS360 Pre-Installation Procedures Manual* (Middleby Marshall P/N 88210-0024) or contact your local Authorized Service Agent.

### NOTE

There must be adequate clearance between the oven and combustible construction. Clearance must also be provided for servicing and for operation.

### NOTE

Wiring diagrams are contained in this manual (Section 5, "Electrical Schematics") and are also located inside the Machinery Compartment Access Panel.

### NOTE

*All aspects of the oven installation, including placement, utility connections, and ventilation requirements, must conform with any applicable local and national codes. These codes supercede the requirements and guidelines provided in this manual.*

### NOTE

*In U.S.A., the oven installation must conform with local codes, or in the absence of local codes, with the National Fuel Gas Code, ANSI Z223.1. The oven, when installed, must be electrically grounded in accordance with local codes, or in the absence of local codes, with the National Electrical Code (NEC), or ANSI/NFPA70.*

### NOTE

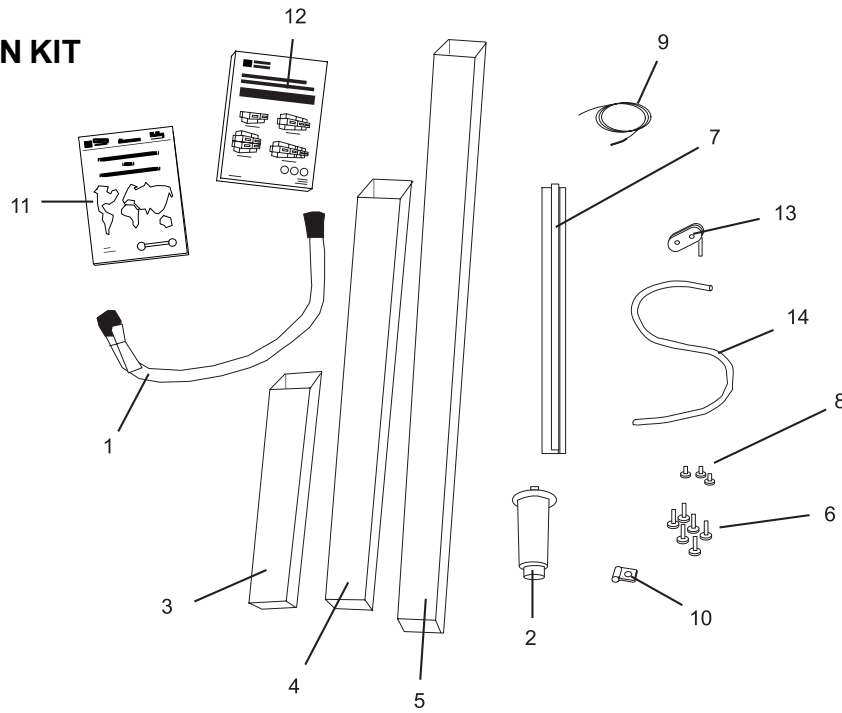
*In Canada, the oven installation must conform with local codes, or in the absence of local codes, with the Natural Gas Installation Code, CAN/CGA-B149.1, or the Propane Gas Installation Code, CAN/CGA-B149.2, as applicable. The oven, when installed, must be electrically grounded in accordance with local codes, or in the absence of local codes, with the Canadian Electrical Code CSA, C22.2, as applicable.*

### NOTE

*For Australian installation, the oven installation must conform with AGA Code, AG601, and with any requirements of the appropriate statutory authority.*

**SECTION 2  
INSTALLATION**

**I. INSTALLATION KIT**



**Fig. 2-1 - Installation Kit**

Item	Part #	Description	Tandem	Double Tandem	Tri Tandem	Quad Tandem
1	22361-0001	Flexible Gas Hose	2	4	3	4
2	22450-0028	Adjustable Legs	8	8	12	16
3	30773	Flue Vent, 14"Lg.	2	-	-	-
4	30759	Flue Vent, 29-1/2"Lg.	-	2	3	4
5	30758	Flue Vent, 50" Lg.	-	2	-	-
6	21256-0008	Screw, 10-32 x 3/8	A/R	A/R	A/R	A/R
7	35000-1103 35000-1899	Conveyor End Stop - PS360 Conveyor End Stop - PS360WB	1	2	-	-
8	21292-0001	Scr, #2PT 10-16 x 3/4 Hx Wsh	A/R	A/R	A/R	A/R
9	33984	Thermocouple	2	4	3	4
10	27276-0001	Cable Clamp	2	4	3	4
11	1002040	Warranty, Parts & Serv. Dist.List	1	1	1	1
12	39223	Owners Operating and Installation Manual (English)	1	1	1	1
13	27126-0238	11 Piece Hex Key Set	1	1	1	1
14	31389	Silicone Tubing, 36" (914mm) L x 5/16" (8mm) ID x 7/16" (11mm) OD	2	4	3	4
-	35000-1454	Machinery Compartment Trim Strip	1	2	2	2
-	35000-1456	Front Gasket Spacer	2	4	4	4
-	35000-1457	Rear Gasket Spacer	2	4	4	4
-	37200-0013 32483	Baking Chamber Gasket and Frame - PS360 Baking Chamber Gasket and Frame - PS360WB	1	2	2	2

**II. TRANSITION CHAMBER COMPONENTS (Quad Tandem Ovens Only)**

Qty.	Part #	Description
1	48009-0025	Side Wall
1	35000-1748	Rear Support
2	35000-1749	Front Support
2	37000-0697 32455	Top Support Channel - PS360 Top Support Channel - PS360WB

Qty.	Part #	Description
1	37000-0696 32457	Floor Panel - PS360 Floor Panel - PS360WB
1	48009-0024 32456	Top Panel - PS360 Top Panel - PS360WB

III. VENTILATION SYSTEM

**IMPORTANT**

**Where national or local codes require the installation of fire suppression equipment or other supplementary equipment, DO NOT mount the equipment directly to the oven.**

**MOUNTING SUCH EQUIPMENT ON THE OVEN MAY:**

- **VOID AGENCY CERTIFICATIONS**
- **RESTRICT SERVICE ACCESS**
- **LEAD TO INCREASED SERVICE EXPENSES FOR THE OWNER**

**A. REQUIREMENTS**

A mechanically driven ventilation system is required for the oven.

**PROPER VENTILATION OF THE OVEN IS THE RESPONSIBILITY OF THE OWNER.**

**B. RECOMMENDATIONS**

NOTE THAT THE HOOD DIMENSIONS SHOWN IN FIGURE 2-2 ARE RECOMMENDATIONS ONLY. LOCAL AND NATIONAL CODES WILL VARY, AND MUST BE FOLLOWED WHEN INSTALLING THE VENTILATION SYSTEM. ANY APPLICABLE LOCAL AND NATIONAL CODES SUPERSEDE THE RECOMMENDATIONS SHOWN IN THIS MANUAL.

The rate of air flow exhausted through the ventilation system may vary depending on the oven configuration and hood design. Consult the hood manufacturer or ventilation engineer for these specifications.

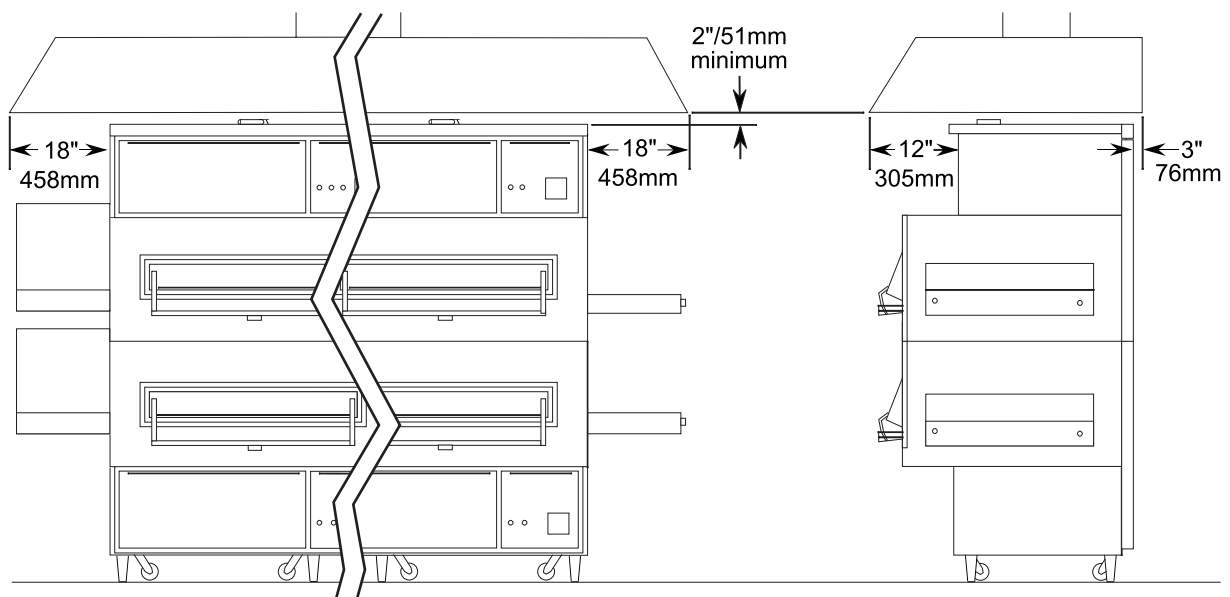
To avoid a negative pressure condition in the kitchen area, return air must be brought back to replenish the air that was exhausted. A negative pressure in the kitchen can cause heat-related problems to the oven components as if there were no ventilation at all. The best method of supplying return air is through the heating, ventilation and air conditioning (HVAC) system. Through the HVAC system, the air can be temperature-controlled for summer and winter. Return air can also be brought in directly from outside the building, but detrimental effects can result from extreme seasonal hot and cold temperatures from the outdoors.

**NOTE:** Return air from the mechanically driven system must not blow at the opening of the baking chamber. Poor oven baking performance will result.

**C. OTHER VENTILATION CONCERNS**

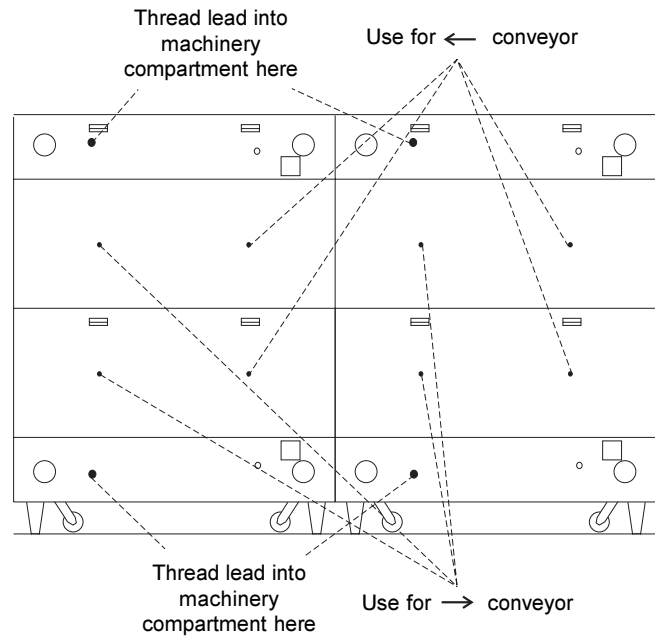
- Special locations, conditions, or problems may require the services of a ventilation engineer or specialist.
- Inadequate ventilation can inhibit oven performance.
- It is recommended that the ventilation system and ductwork be checked at prevailing intervals as specified by the hood manufacturer and/or HVAC engineer or specialist.

**Fig. 2-2 - Ventilation System**



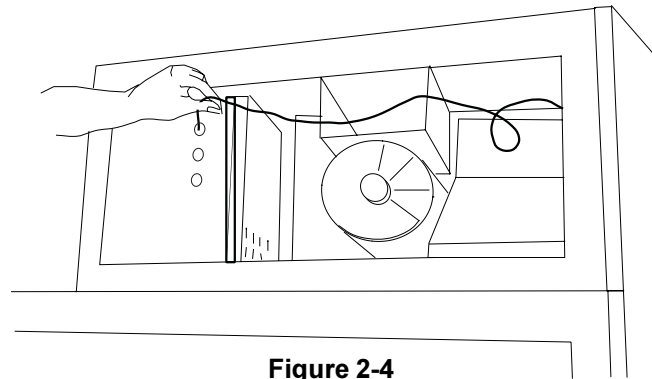
## IV. THERMOCOUPLE INSTALLATION

1. Install the thermocouple sensing bulb into the correct hole in the rear of the oven, as shown in Figure 2-3.



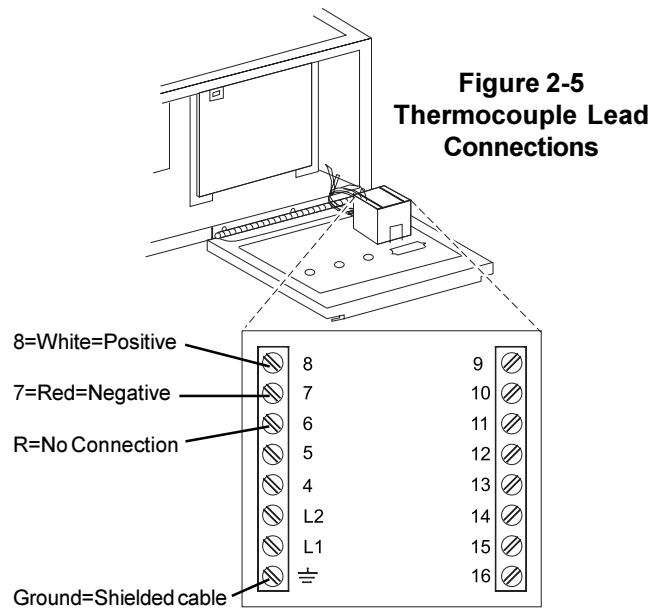
**Figure 2-3**  
**Thermocouple Installation Locations**

2. Thread the thermocouple lead through the grommet and into the machinery compartment.
3. Remove the right-side access panel of the machinery compartment.
4. Thread the thermocouple lead through the side of the machinery compartment as shown in Figure 2-4, and into the electrical box (at the right-front of the machinery compartment).



**Figure 2-4**  
**Placing the Thermocouple Leads**

5. Connect the thermocouple leads to the temperature controller as shown in Figure 2-5.
6. Repeat Steps 1-5 for each of the other oven sections in the installation.

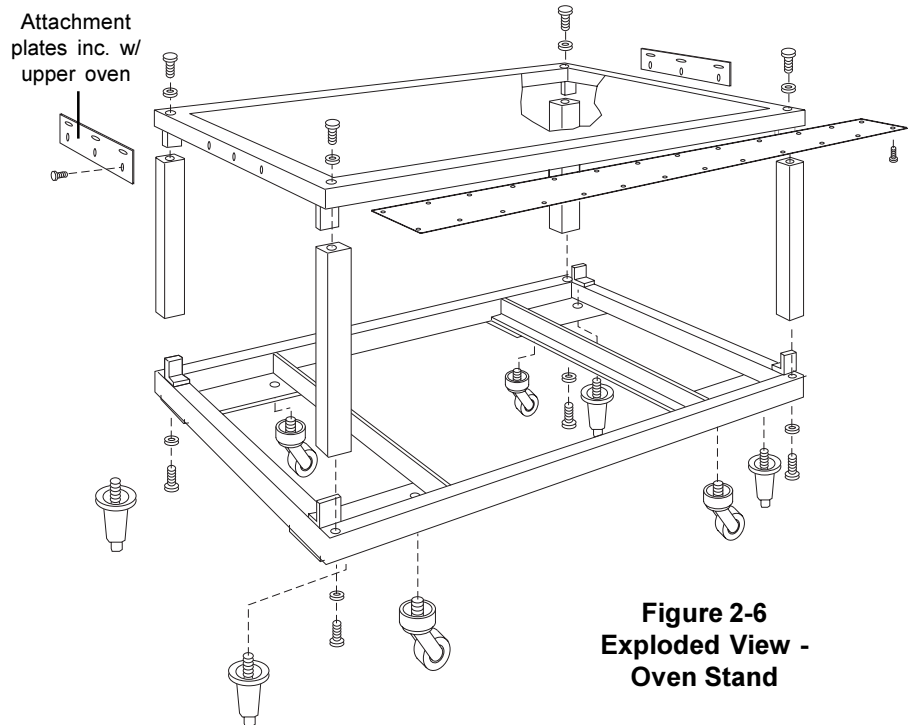


## V. ASSEMBLY

### A. OVENSTAND

If the installation includes upper ovens mounted atop lower ovens, the ovens must be stacked before joining the tandem ovens together.

If the installation includes ovens that are to be mounted on stands, assemble the ovens to the stands before joining the ovens together. An exploded view of the stand is shown in Figure 2-6.



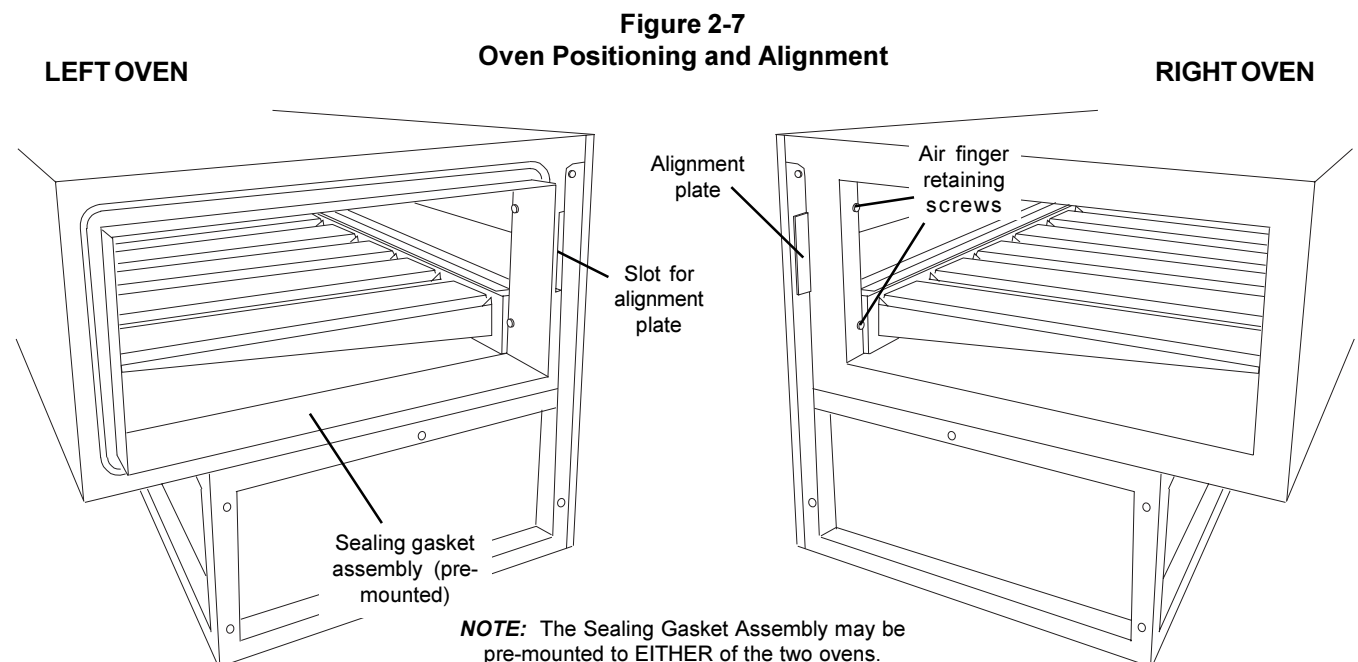
### B. JOINING THE OVEN BODIES

For TANDEM and DOUBLE TANDEM installations, perform Steps 1-8 in this section to join the ovens.

For TRI TANDEM installations, perform Steps 1-8 to join two of the ovens together, and ensure that they are level; then, repeat Steps 1-8 to join the third oven to the two that have already been assembled.

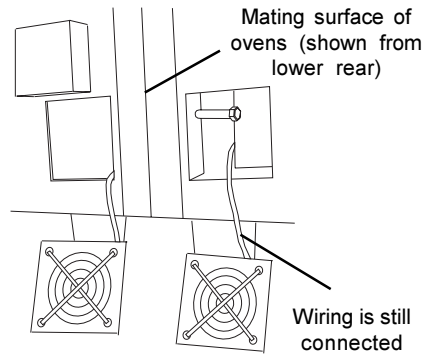
For QUAD TANDEM installations, perform Steps 1-8 for EACH PAIR of ovens, producing two sets of two joined ovens. Do not assemble the center bridge section at this time.

1. Determine the proper position of the ovens by referring to Figure 2-7. Then, move the ovens to their approximate final locations.
2. Check that the top and bottom air finger retaining screws are present on *all mating ends* of the oven sections. See Figure 2-7. The screws prevent the air fingers from sliding in between the oven sections.



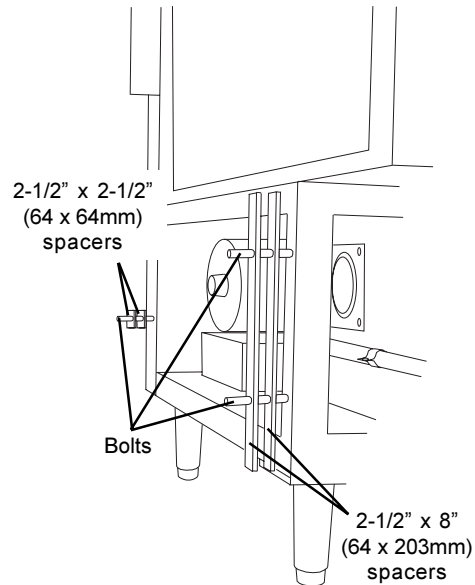
## SECTION 2 INSTALLATION

3. Remove the rear axial cooling fans that are adjacent to the mating sides of the ovens. The fans may either be completely disconnected, or left attached by their wiring as shown in Figure 2-8.



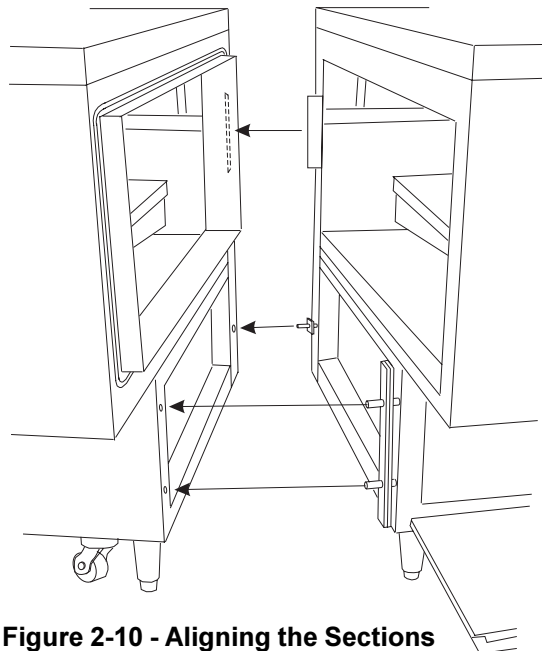
**Figure 2-8 - Cooling Fan Removal**

4. Insert three of the supplied  $1/2 \times 5$ " bolts through the holes in the frame of the right oven, pointing outward as shown in Figure 2-9. Then, slide the spacers into place on the bolts.



**Figure 2-9 - Bolts and Spacers**

5. Push the ovens together. Check that the mounting bolts, alignment plate, and sealing gasket are all properly aligned. See Figure 2-10.
6. Tighten all of the attaching bolts. Check that the mating edges of the ovens align properly. If gaps appear between the tops of the ovens, it will be necessary to loosen the connecting bolts and realign the ovens.



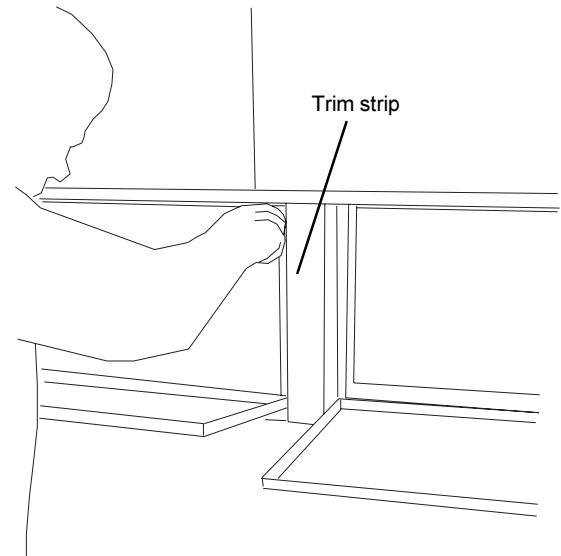
**Figure 2-10 - Aligning the Sections**

7. Attach the front trim strip between the two ovens, as shown in Figure 2-11.
8. Replace the rear axial cooling fans. See Figure 2-8.
9. Perform one of the following, as appropriate:
  - For PS360/360WB Tandem and Double Tandem installations, skip ahead to Part D, INSTALLING THE CONVEYOR FRAME AND BELT (Page 2-9).
  - For PS360/360WB Tri Tandem installations, perform Steps 1-8 again to attach the third oven to the two that have just been assembled. Then, skip ahead to Part D, INSTALLING THE CONVEYOR FRAME AND BELT (Page 2-9).
  - For PS360/360WB Quad Tandem installations, perform Steps 1-8 again to attach the two remaining ovens to each other. Then, continue on to Part C, INSTALLING THE CENTER TRANSITION.

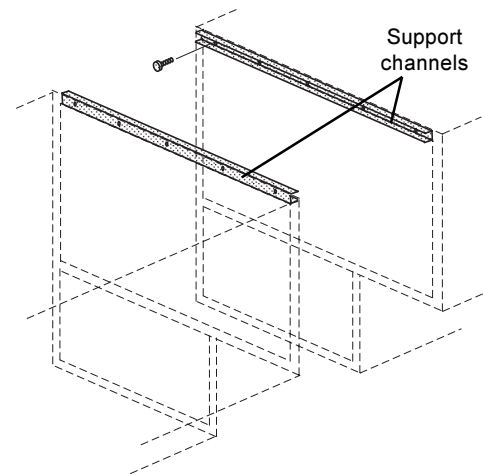
**C. INSTALLING THE CENTER TRANSITION**

1. Install the upper support channels to the two center ovens as shown in Figures 2-12 and 2-13.

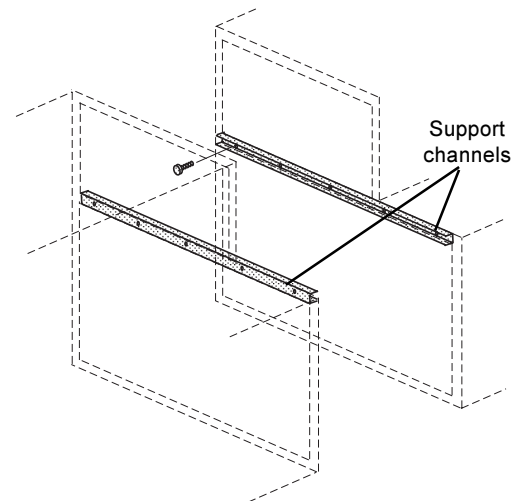
**Figure 2-11 - Trim Strip Installation**



**Figure 2-12  
Support Channel Installation - Lower Oven**



**Figure 2-13  
Support Channel Installation - Upper Oven**

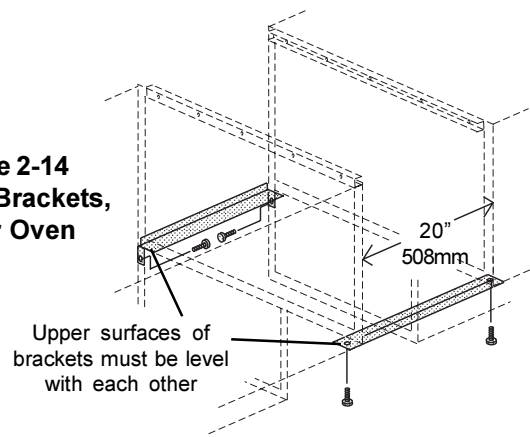


## SECTION 2 INSTALLATION

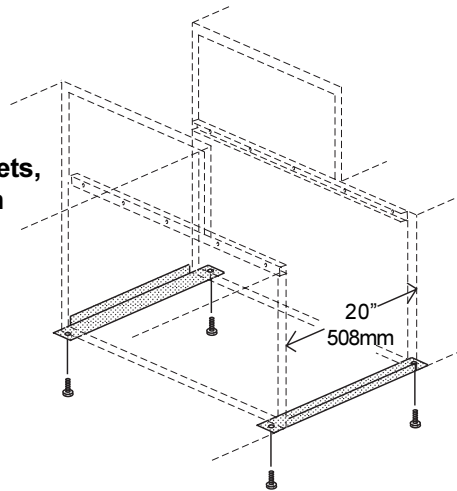
- Align the two center ovens so that they are level and 20" (508mm) apart. Then, attach the two angled support brackets between the two center ovens, as shown in Figures 2-14 and 2-15.

Note that a LOWER OVEN uses different support brackets for the front and rear, while an UPPER OVEN uses identical brackets on the front and rear.

**Figure 2-14**  
**Support Brackets,**  
**Lower Oven**

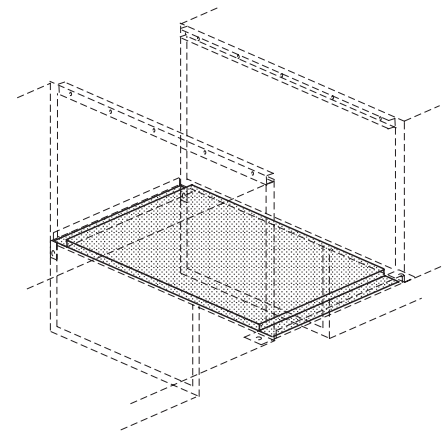


**Figure 2-15**  
**Support Brackets,**  
**Upper Oven**



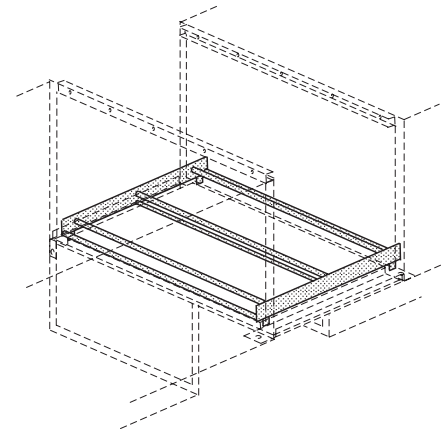
- Place the transition floor panel into place atop the support brackets. See Figure 2-16.

**Figure 2-16**  
**Floor Panel**  
**Installation**



- Install the transition (center) conveyor section, as shown in Figure 2-17. Align the conveyor section so that it extends the same distance into the two oven chambers.

**Figure 2-17**  
**Installing**  
**the Frame**

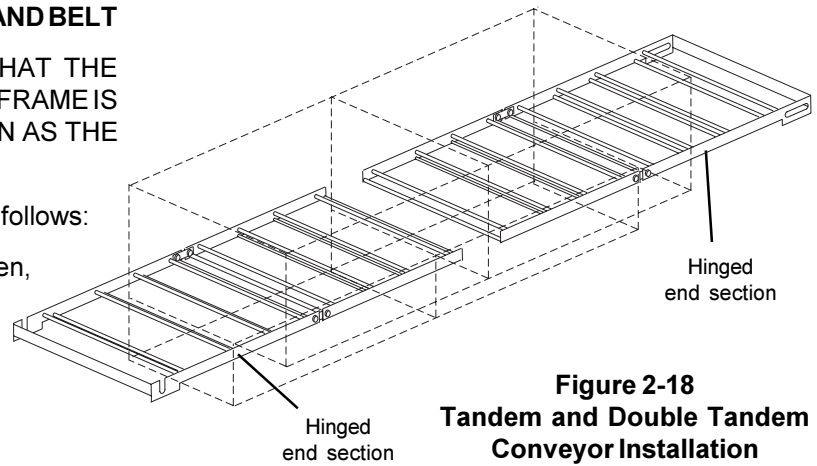


**D. INSTALLING THE CONVEYOR FRAME AND BELT**

FOR ALL TYPES OF OVENS, ENSURE THAT THE DRIVE SECTION/END OF THE CONVEYOR FRAME IS PLACED ON THE SAME END OF THE OVEN AS THE CONVEYOR DRIVE MOTOR.

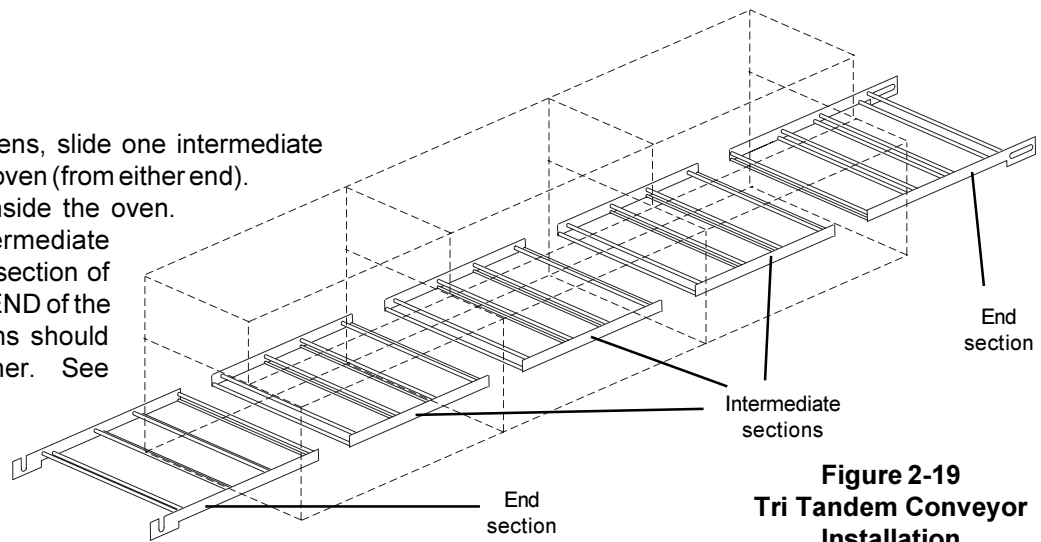
1. Insert the conveyor frame into the oven as follows:

For a TANDEM or DOUBLE TANDEM oven, slide one hinged conveyor frame section into each end of the oven. The two sections butt against each other at the gap between the two oven sections. See Figure 2-18.



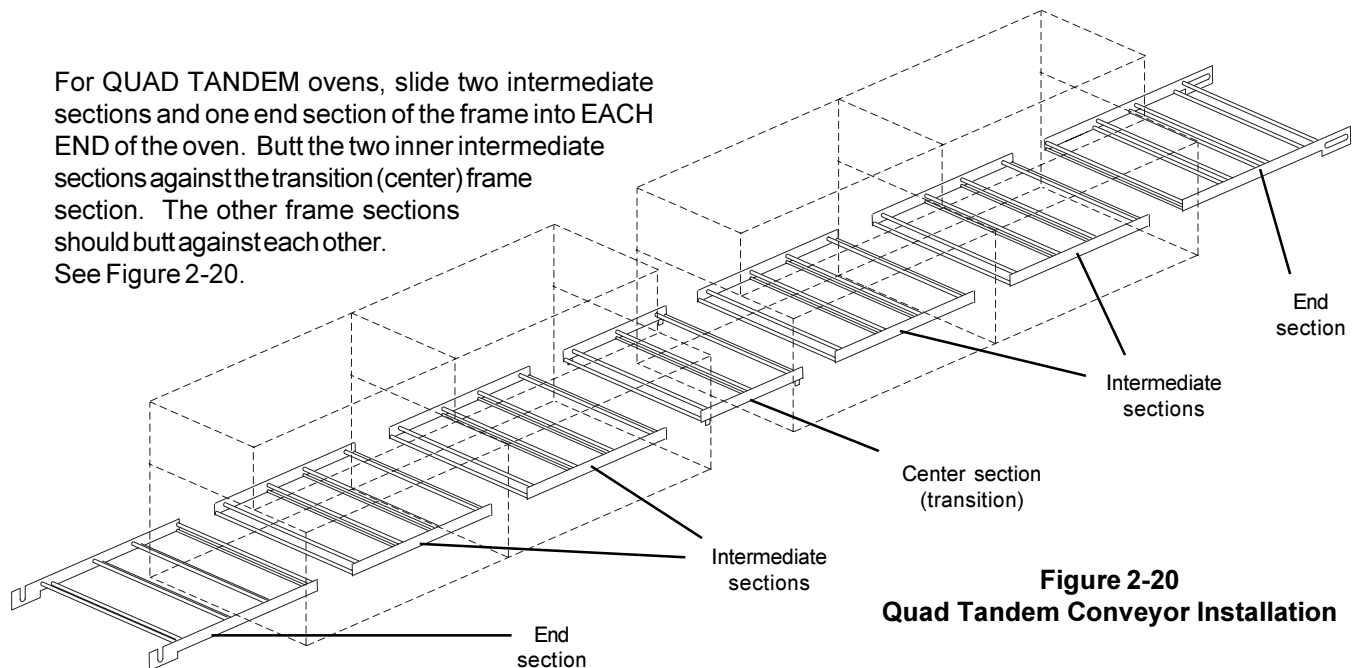
**Figure 2-18  
Tandem and Double Tandem  
Conveyor Installation**

For TRI TANDEM ovens, slide one intermediate frame section into the oven (from either end). Center this section inside the oven. Then, slide one intermediate section and one end section of the frame into EACH END of the oven. All five sections should butt against each other. See Figure 2-19.



**Figure 2-19  
Tri Tandem Conveyor  
Installation**

For QUAD TANDEM ovens, slide two intermediate sections and one end section of the frame into EACH END of the oven. Butt the two inner intermediate sections against the transition (center) frame section. The other frame sections should butt against each other. See Figure 2-20.



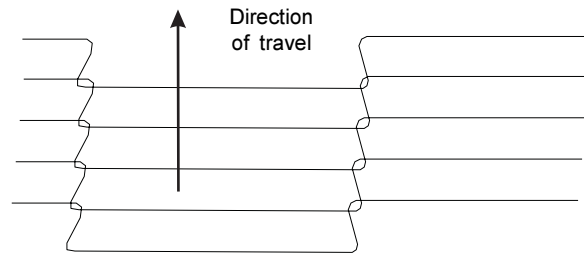
**Figure 2-20  
Quad Tandem Conveyor Installation**

## SECTION 2 INSTALLATION

- Slide the conveyor belt through the support rods underneath the frame, and thread it through the oven. Then, reach through the oven window and pull the free end of the belt through the oven so that it lies atop the conveyor frame.

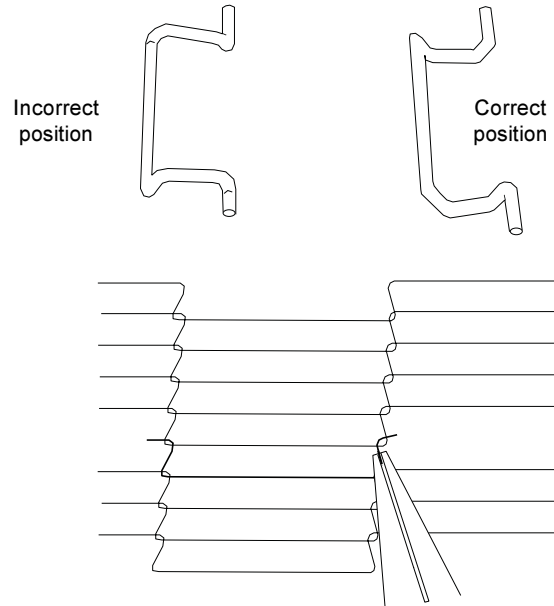
After the belt has been pulled through the oven, check the following:

- The conveyor belt links must be oriented as shown in Figure 2-21.
- The smooth side of the conveyor belt must face UP.



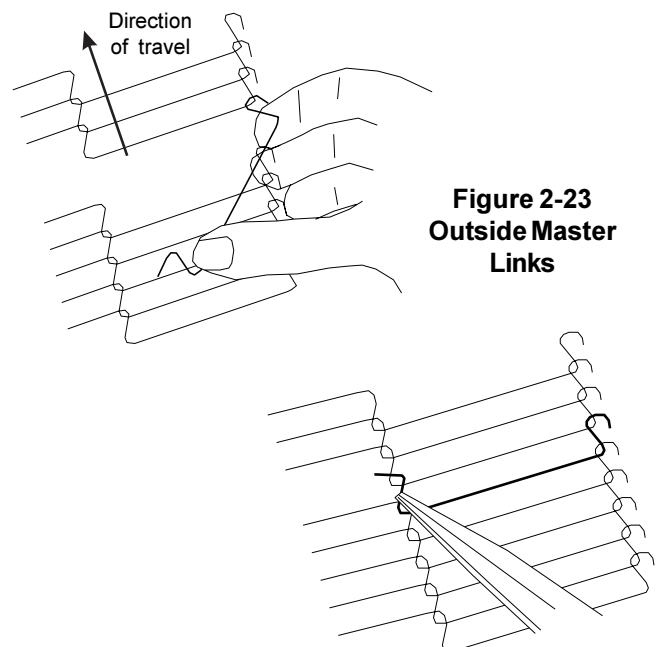
**Figure 2-21 - Conveyor Link Orientation**

- Connect the inside master links. Check that the links are oriented as shown in Figure 2-22.



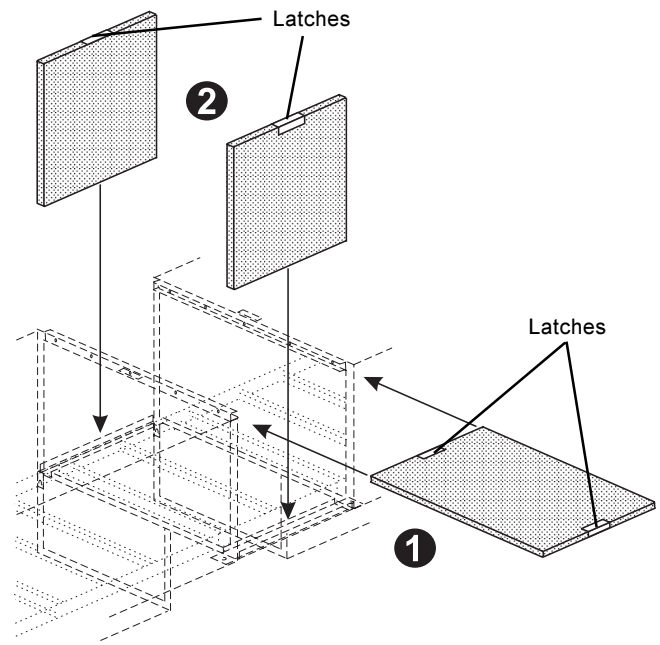
**Figure 2-22 - Inside Master Links**

- Connect the outside master links. Note that the outside master links have right and left sides. The right-side master link has an open hook facing you, as shown in Figure 2-23.



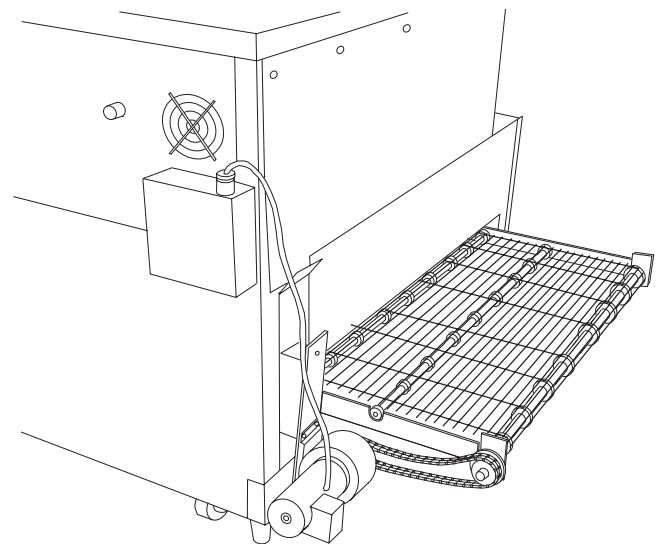
**Figure 2-23  
Outside Master Links**

5. For a TANDEM, DOUBLE TANDEM, or TRI TANDEM oven installation, skip ahead to Step 9. For a QUAD TANDEM oven installation, continue on to Step 6.
6. Slide the top transition panel into place. Then, slide the two transition side panels into place. See Figure 2-24.
7. If the four latches are not already attached to the side and top transition panels, attach them in place as shown in Figure 2-24.
8. Fasten the latches on the side and top panels to hold the panels in place.



**Figure 2-24 - Transition Section Final Assembly**

9. LOOSELY attach the conveyor drive motor to the end wall of the oven, as shown in Figure 2-25.
10. Assemble the conveyor drive chain in place on the motor and conveyor drive sprockets.
11. Position the motor to adjust the tension of the drive chain. The deflection of the chain should be 3/4" (19mm). **DO NOT OVERTIGHTEN THE DRIVE CHAIN.** Then, tighten the motor in place.
12. Assemble the end plugs and motor housing onto the oven.
13. **TANDEM AND DOUBLE TANDEM OVENS ONLY:** Assemble the end stops, conveyor crumb trays, and conveyor extension covers onto the oven. These components are illustrated in Figure 1-1 (Page 1-2).



**Figure 2-25  
Conveyor Motor and Drive Chain Assembly**

SECTION 2  
INSTALLATION

VI. ELECTRICAL SUPPLY

**WARNING**

Authorized supplier personnel normally accomplish the connections for the ventilation system, electric supply, and gas supply, as arranged by the customer. Following these connections, the factory-authorized installer can perform the initial startup of the oven.

**NOTE:** *The electric supply installation must satisfy the requirements of the appropriate statutory authority, such as the National Electrical Code (NEC), ANSI/NFPA70, (U.S.A.); the Canadian Electrical Code, CSA C22.2; the Australian Code AG601; or other applicable regulations.*

**NOTE:** *The electric supply connection must meet all national and local electrical code requirements.*

Check the oven data plate before making any electric supply connections. Electric supply connections must agree with data on the oven data plate. See Figure 2-26.

A fused disconnect switch or a main circuit breaker (customer furnished) **MUST** be installed in the electric supply line for each oven. It is recommended that this switch/circuit breaker have lockout/tagout capability.

The supply conductors must be of the size (#14 AWG, copper) recommended. Refer to the wiring diagrams in Section 5 of this manual.

All gas oven electric supply connections are made via the electrical junction box on the rear of the oven, shown in Figure 2-27. The power lines then connect to the oven circuits through the Machinery Compartment Access Panel Safety Switch. This switch interrupts electric power to the oven when the Machinery Compartment Access Panel is opened.

**CAUTION**

Before connecting incoming power to the oven, measure the voltage of each input leg to neutral. The expected voltage is approximately 120V. ANY voltage reading exceeding 130V indicates that the supply has a "high" leg. **CONNECTING A "HIGH" LEG TO THE OVEN VOIDS ALL OVEN WARRANTIES.** Connecting a "high" leg to the black lead of the oven can severely damage the oven's electrical and electronic components.

**CAUTION**

**DO NOT CONNECT BLACK WIRE TO HIGH LEG. VOLTAGE OF THE BLACK AND WHITE WIRES MUST BE NO HIGHER THAN 130 VAC**

FOR DOMESTIC OVENS (WITHOUT EXTERNAL TRANSFORMERS):


In the junction box on the rear of the oven, connect one 208 - 240V supply line to the black wire and the other 208 - 240V supply line to the red wire. Connect the electric supply ground wire to the oven ground screw located in the junction box. If necessary, have the electrician supply the ground wire. *Do NOT use the wiring conduit or other piping for ground connections!*

FOR EXPORT OVENS (WITH EXTERNAL TRANSFORMERS):

First, position the transformer on the LEFT REAR wall of the oven (as space permits), and fasten it in place using the supplied mounting hardware.

Then, refer to the appropriate wiring diagram in Section 5 of this manual to determine the correct transformer connections for the supply lines. Connect the electric supply ground wire to the oven ground screw located in the junction box. If necessary, have the electrician supply the ground wire. *Do NOT use the wiring conduit or other piping for ground connections!*

**Figure 2-26  
Oven Data Plate**

	<p>SUITABLE FOR INSTALLATION ON COMBUSTIBLE FLOORS ADJACENT TO COMBUSTIBLE AND NONCOMBUSTIBLE WALLS WITH THE FOLLOWING MINIMUM CLEARANCES: ZERO INCHES TO THE SIDE WALLS, ONE INCH TO THE BACK WALL.</p> <p><b>*INTENDED FOR OTHER THAN HOUSEHOLD USE*</b> FOR INSTALLATION UNDER VENTILATING HOOD ONLY</p>
<p>MODEL NO. <input type="text"/> SERIAL NO. <input type="text"/></p> <p>ID NO. <input type="text"/> TYPE OF GAS <input type="text"/></p> <p>M J / h <input type="text"/> GAS RATE <input type="text"/></p> <p>MAN. PRESS. <input type="text"/> K P A <input type="checkbox"/> WIRE WITH GROUND <input type="checkbox"/></p> <p><input type="text"/> VAC <input type="text"/> AMPS <input type="text"/> PHASE <input type="text"/> HZ.</p>	<p>ELGIN, ILLINOIS, 60120, U.S.A.</p>

VII. GAS SUPPLY

**CAUTION**  
DURING PRESSURE TESTING NOTE ONE OF THE FOLLOWING:

1. The oven and its individual shutoff valve must be disconnected from the gas supply piping system during any pressure testing of that system at test pressure in excess of 1/2 psi (3.45 kPa).
2. The oven must be isolated from the gas supply piping system by closing its individual manual shutoff valve during any pressure testing of the gas supply piping system at test pressure equal to or less than 1/2 psi (3.45 kPa).
3. If incoming pressure is over 14" W.C. (35mbar), a separate regulator MUST be installed in the line BEFORE the individual shutoff valve for the oven.

**WARNING:** To prevent damage to the control valve regulator during initial turn-on of gas, it is very important to open the manual shutoff valve very slowly.

After the initial gas turn-on, the manual shutoff valve must remain open except during pressure testing as outlined in the above steps or when necessary during service maintenance.

**A. CONNECTION**

Check the oven's gas supply requirements before making the gas utility connection. Gas supply requirements are listed on the oven's data plate (Figure 2-26) and in the Oven Specifications table (Page 1-1 of this manual).

Check the oven data plate (see Figure 2-26) to determine the type of gas (Propane or Natural) to be used with the oven.

Refer to the instructions in the gas hose package (included in the Base Pad Kit) before connecting the gas line. One gas line connection method is shown in Figure 2-28; however, compliance with the applicable standards and regulations is mandatory.

Inlet, regulated, and pilot gas pressure readings can be taken using a "U" tube manometer at the tap locations shown in Figure 2-29.

One 90° elbow equals a 4' (1.22m) length of pipe. The recommended pipe sizes are larger than usually required to eliminate any operation problems. It is much less expensive to make the initial installment large enough to do the job rather than redoing the job later.

**NOTE**

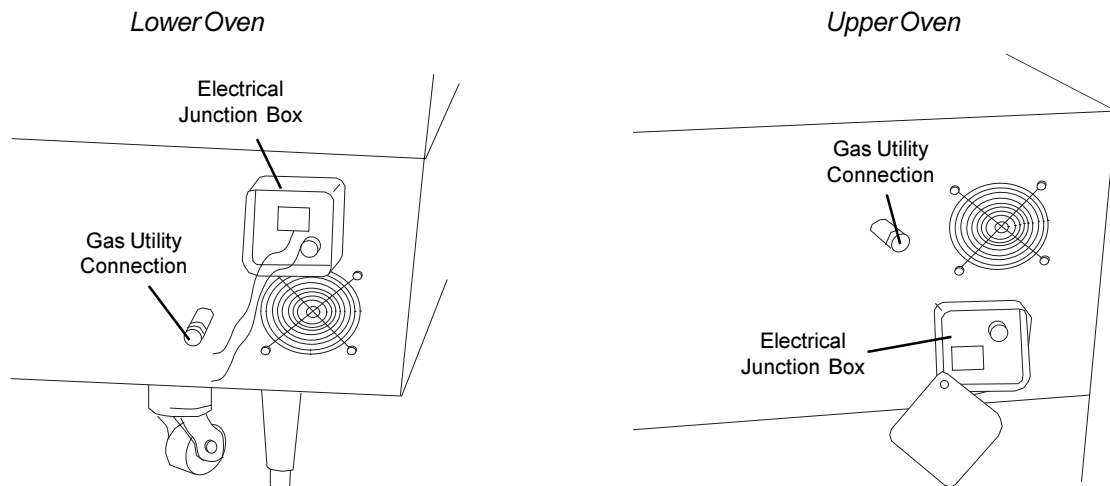
*The installation must conform with local codes or in the absence of local codes, with the National Fuel Gas Code, ANSI Z223.1-latest edition.*

*In Australia, the installation must conform with AGA Code AG601 and with any requirements of the appropriate statutory authority.*

**CANADIAN:**

*CAN/CGA-B 149.1 Natural Gas Installation Code  
CAN/CGA-B 149.2 Propane Installation Code*

**Figure 2-27  
Utility Connection Locations**



## SECTION 2 INSTALLATION

Certain safety code requirements exist for the installation of gas ovens; refer to the beginning of Section 2 for a list of the installation standards. In addition, because the oven is equipped with casters, the gas line connection shall be made with a connector that complies with the Standard for Connectors for Movable Gas Appliances, ANSI Z21.69 (in U.S.A.), or, if applicable, Connectors for Movable Gas Appliances, CAN/CGA-6.16 (in Canada), as well as a quick-disconnect device that complies with the Standard for Quick-Disconnect Devices for Use With Gas Fuel, ANSI Z21.41 (in U.S.A.), or, if applicable, Quick-Disconnect Devices for Use With Gas Fuel, CAN1-6.9 (in Canada).

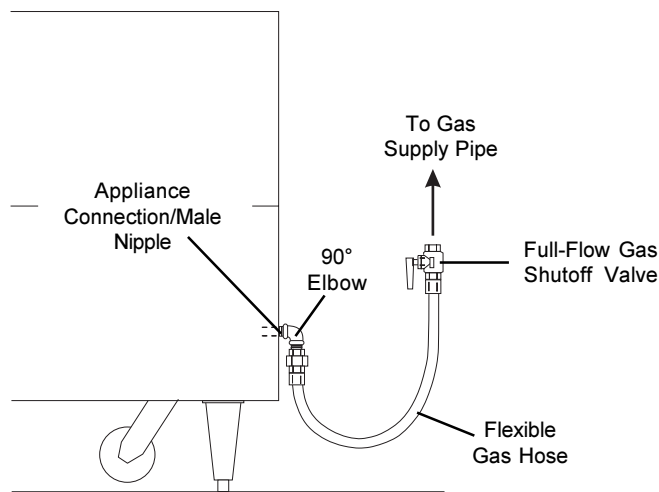
### B. GAS CONVERSION

It is possible to convert ovens from natural to propane gas, or from propane to natural gas, by changing the main and pilot orifices.

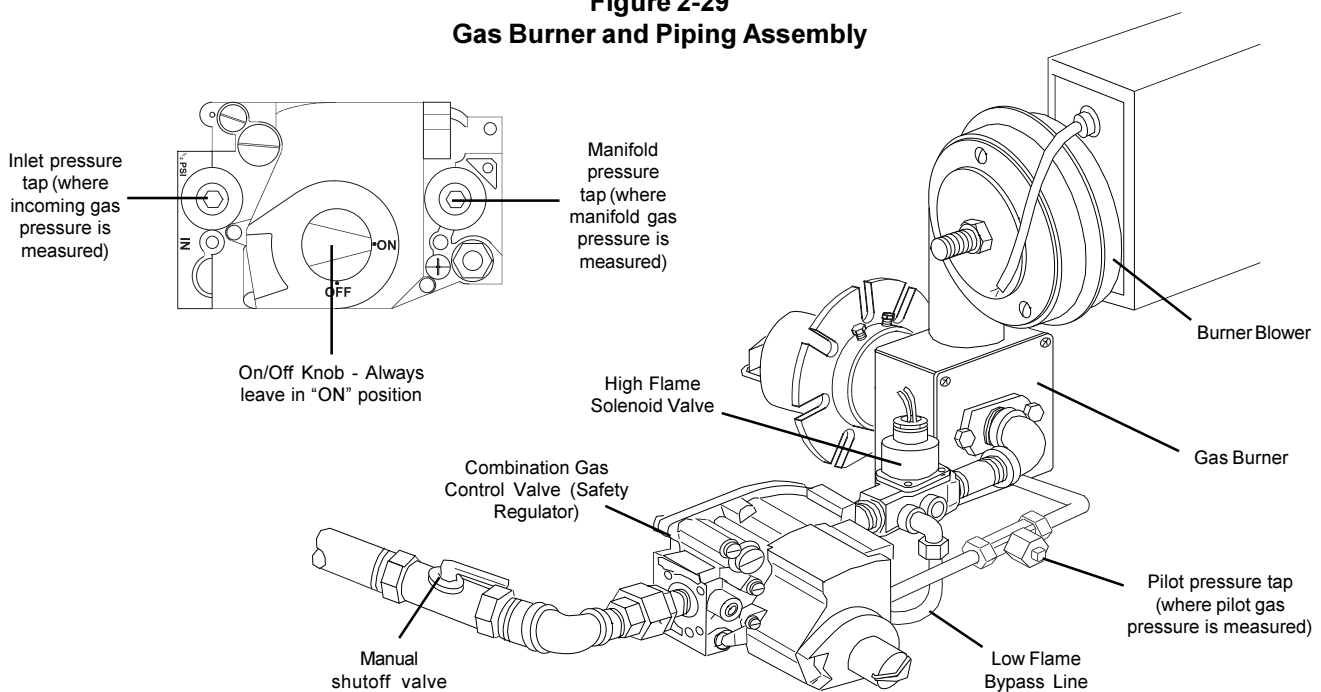
**WARNING:** All installations, conversions and service work must be performed by an authorized service agent.

**NOTE:** In Canada, to conform with the CAN/CGA-B149.2 propane installation code, the oven must be ordered propane. It may not be converted in the field.

**Figure 2-28**  
**Flexible Gas Hose Installation**



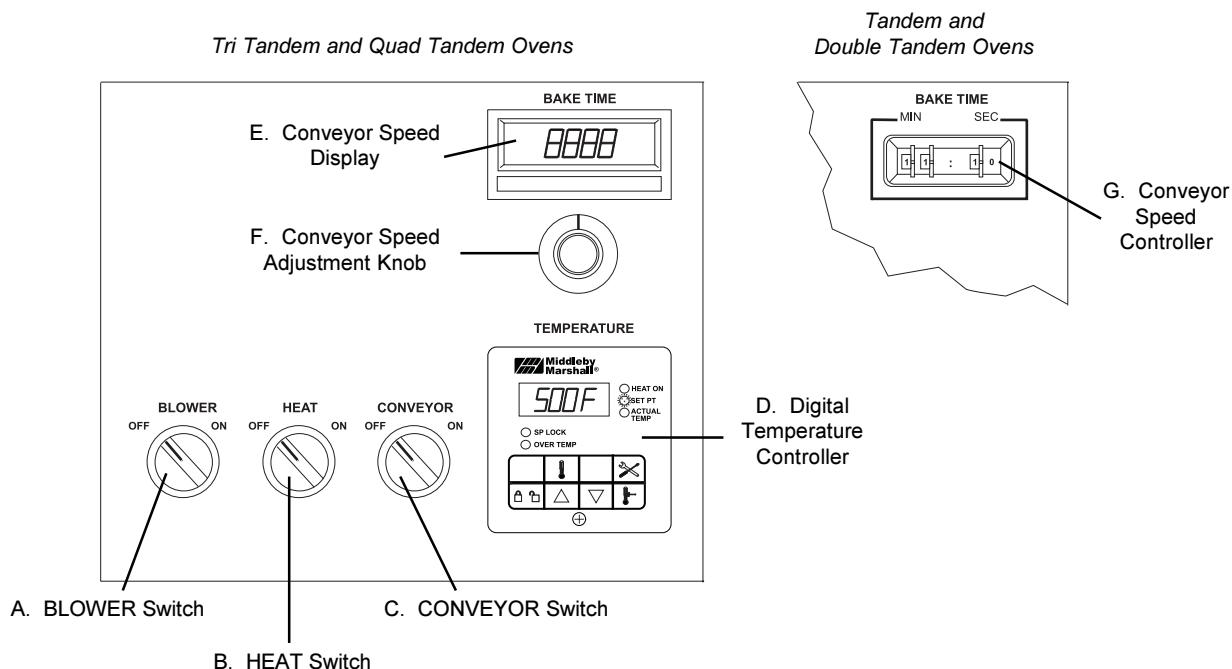
**Figure 2-29**  
**Gas Burner and Piping Assembly**



# SECTION 3 OPERATION

**IMPORTANT**  
**THESE OVENS ARE INTENDED FOR PROFESSIONAL USE ONLY.**  
**THE OVENS MAY ONLY BE OPERATED BY QUALIFIED PERSONNEL.**

## I. LOCATION AND DESCRIPTION OF CONTROLS



**Fig. 3-1 - Control Panel**

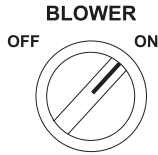
- A. BLOWER Switch:** Turns the blowers and cooling fans on and off. The HEAT Switch has no effect unless the BLOWER Switch is in the "ON" position.
  - B. HEAT Switch:** Allows the gas burner to light. Activation of the gas burner is determined by the settings on the Digital Temperature Controller.
  - C. CONVEYOR Switch:** Turns the conveyor drive motor on and off. This switch is only present on oven sections that have a conveyor drive motor.
  - D. DIGITAL TEMPERATURE CONTROLLER:** A solid-state, on-off type controller that continuously monitors the oven temperature. Settings on the Digital Temperature Controller control the activation of the gas burner.
  - E. CONVEYOR SPEED DISPLAY (Tri Tandem and Quad Tandem ovens only):** Displays a DC voltage value that corresponds to the speed of the conveyor drive motor. Higher voltages produce a faster conveyor speed, shortening the bake time. The display is only present on oven sections that have a conveyor drive motor.
  - F. CONVEYOR SPEED ADJUSTMENT KNOB (Tri Tandem and Quad Tandem ovens only):** Adjusts the speed of the conveyor drive motor. The knob is only present on oven sections that have a conveyor drive motor.
  - G. CONVEYOR SPEED CONTROLLER (Tandem and Double Tandem ovens only):** Adjusts and displays the bake time. This control is only present on oven sections that have a conveyor drive motor.
- NOT SHOWN:**
- H. MACHINERY COMPARTMENT ACCESS PANEL SAFETY SWITCH:** Disconnects electrical power to the controls and the blowers when the machinery compartment access panel is opened. This panel should only be opened by authorized service personnel.

SECTION 3  
OPERATION

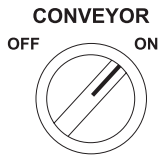
II. NORMAL OPERATION - STEP-BY-STEP

A. DAILY STARTUP PROCEDURE

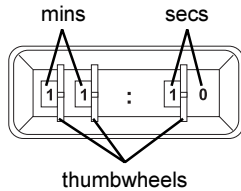
1. Check that the circuit breaker/fused disconnect is in the on position. If the oven is equipped with a window, check that the window is closed.
2. Turn the BLOWER switch to the "ON" position.



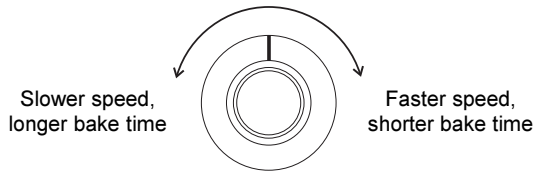
3. Turn the CONVEYOR switch to the "ON" position.



4. Adjust the conveyor speed setting, if necessary.
  - For TANDEM and DOUBLE TANDEM ovens, turn the three thumbwheels to change the displayed bake time.

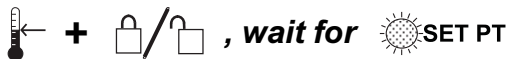


- For TRI TANDEM and QUAD TANDEM ovens, turn the knob to change the conveyor speed.

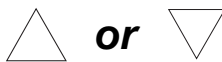


5. Adjust the temperature controller to a desired set temperature, if necessary.

- Press the Set Point and Unlock keys at the same time. Wait for the SET PT light to turn on.



- Press the Up Arrow and Down Arrow Keys as necessary to adjust the setpoint.



6. Turn the HEAT switch to the ON position, and wait for the HEAT ON light to turn on.



7. Wait for the oven to heat to the setpoint temperature. Higher setpoint temperatures will require a longer wait. The oven can reach a temperature of 500°F (232°C) in approximately 5 minutes.

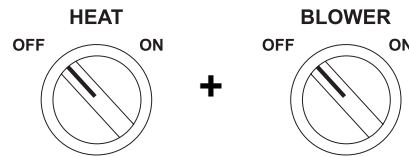
8. (Optional) Press the Temperature Key once to show the Actual Temperature in the display, and wait for the ACTUAL TEMP light to turn on. This allows you to monitor the oven temperature as it rises to the setpoint.



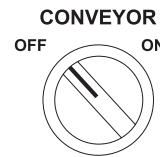
9. Allow the oven to preheat for 10 minutes after it has reached the set point temperature.

B. DAILY SHUTDOWN PROCEDURE

1. Turn the HEAT and BLOWER switches to OFF. Note that the blowers will remain in operation until the oven has cooled to below 200°F (93°C).



2. Make certain that there are no products left on the conveyor inside the oven. Turn the CONVEYOR switch to OFF.



3. If the oven is equipped with a window, open the window to allow the oven to cool faster.

4. After the oven has cooled and the blowers have turned off, switch the circuit breaker/fused disconnect to the off position.

**CAUTION**

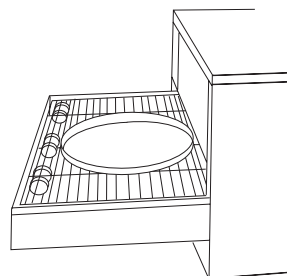
In case of power failure, turn all switches to the "OFF" position, open the oven window, and remove the product. After the power has been restored, perform the normal startup procedure.

**The burner will not operate and gas will not flow through the burner without electric power. No attempt should be made to operate the oven during power failure.**

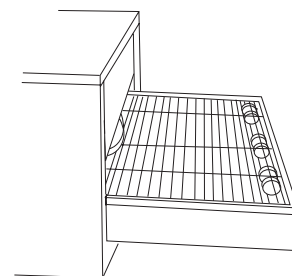
### III. QUICK REFERENCE: CALCULATING THE BAKE TIME

Tandem and Double Tandem ovens display the bake time in minutes and seconds. Tri Tandem and Quad Tandem ovens, however, show a DC voltage value that corresponds to the speed of the conveyor drive motor. To calculate the bake time in minutes and seconds, perform the following procedure.

- With the conveyor running, place a product at the entrance end of the conveyor, as shown in Figure 3-2. Begin timing with a stopwatch.
- When the leading edge of the product exits the bake chamber (as shown in Figure 3-3), end timing.
- The time on the stopwatch is the bake time of the oven. The time can be adjusted as described in Part II of this chapter (NORMAL OPERATION - STEP-BY-STEP).

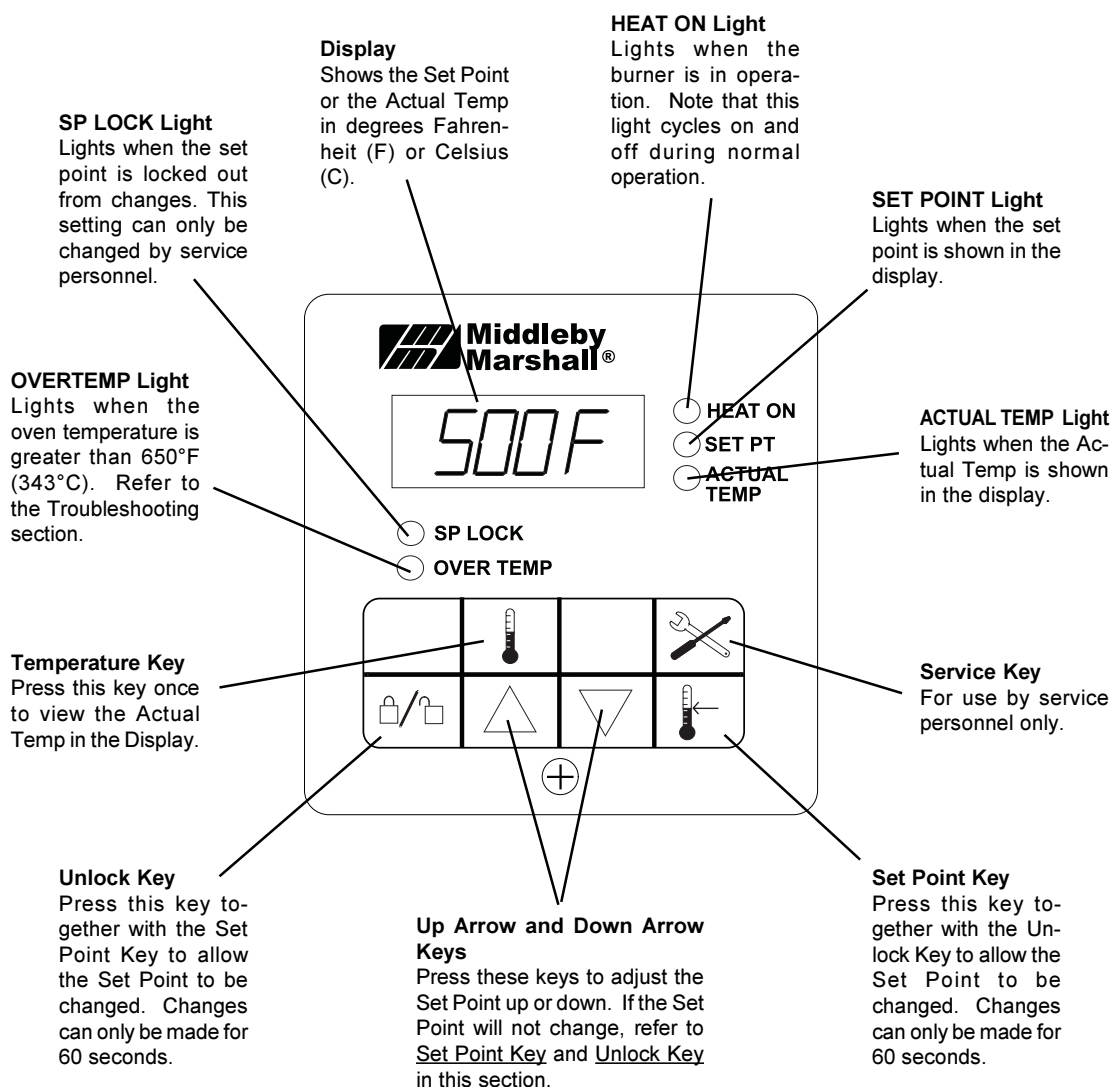


**Fig. 3-2**  
Begin timing





**Fig. 3-3**  
End timing

### IV. QUICK REFERENCE: DIGITAL TEMPERATURE CONTROLLER



SECTION 3  
OPERATION

V. QUICK REFERENCE: TROUBLESHOOTING

SYMPTOM	PROBLEM	SOLUTION
 <p><b>OVERTEMP</b> <i>light is lit, food product is undercooked</i></p>	<p>The oven temperature exceeded 650°F (343°C), and the burner was automatically shut down.</p>	<ul style="list-style-type: none"> <li>Follow the procedures under DAILY SHUTDOWN PROCEDURES to shut down the oven. Contact your Middleby Marshall Authorized Service Agent to determine and correct the cause of the condition to prevent damage to the oven.</li> </ul>
<p><i>Oven will not turn on at all</i></p>	<p>Electrical power may not be reaching the oven, or the controls may be set incorrectly.</p>	<ul style="list-style-type: none"> <li>Check that the circuit breaker/fused disconnect is turned on.</li> <li>Check that the BLOWER Switch is in the “ON” position. The burner cannot engage until the blowers are in operation.</li> </ul>
<p><i>Oven shuts down shortly after it is turned on</i></p>	<p>The gas burner did not light within 90 seconds of turning the HEAT Switch to the “ON” position. This automatically engages a safety lockout mode.</p>	<ul style="list-style-type: none"> <li>Turn the HEAT switch to the “OFF” position.</li> <li>Wait for 60 seconds.</li> <li>Repeat the Daily Startup procedure.</li> </ul>
 <p><i>appears in display, oven is not heating</i></p>	<p>The oven did not reach 200°F (93°C) within 15 minutes of startup, and the oven has stopped heating.</p>	<ul style="list-style-type: none"> <li>Turn the BLOWER Switch to the “OFF” position.</li> <li>Wait for 30 seconds.</li> <li>Repeat the Daily Startup procedure.</li> </ul>
<p><i>Oven will not heat</i></p>	<p>Controls may be set incorrectly.</p>	<ul style="list-style-type: none"> <li>Check that both the BLOWER and HEAT Switches are in the “ON” position.</li> <li>If the oven still will not heat, turn the BLOWER Switch to the “OFF” position.</li> <li>Wait for 30 seconds.</li> <li>Repeat the Daily Startup procedure. Check that the Set Point is above 200°F (93°C).</li> </ul>
<p><i>Oven is operating, but little or no air is blowing from air fingers</i></p>	<p>Airfingers may have been reassembled incorrectly after cleaning.</p>	<ul style="list-style-type: none"> <li>Turn the oven off, and allow it to cool. Disconnect electrical power to the oven.</li> <li>Refer to Section 4, Maintenance, for instructions on reassembling the air fingers.</li> </ul>
<p><i>Conveyor moves with a jerky motion, or will not move at all</i></p>	<p>Conveyor may be jammed on an object in the oven, or conveyor belt or drive chain tension may be incorrect.</p>	<ul style="list-style-type: none"> <li>Turn the oven off, and allow it to cool. Disconnect electrical power to the oven.</li> <li>Check if the conveyor is blocked by an object inside the oven.</li> <li>Refer to Section 4, Maintenance, for instructions on checking the conveyor and drive chain tension.</li> </ul>
<p><i>Food products are overcooked or undercooked.</i></p>	<p>Controls may be set incorrectly.</p>	<ul style="list-style-type: none"> <li>Check that the set temperature and bake time settings are correct.</li> </ul>

**IF THESE STEPS FAIL TO RESOLVE THE PROBLEM, CONTACT YOUR LOCAL MIDDLEBY MARSHALL AUTHORIZED SERVICE AGENT.**

## SECTION 4 MAINTENANCE

### WARNING

Before ANY cleaning or servicing of the oven, perform the following procedure:

1. Switch off the oven and allow it to cool. Do NOT service the oven while it is warm.
2. Turn off the electric supply circuit breaker(s) and disconnect the electric supply to the oven.
3. If it is necessary to move the oven for cleaning or servicing, disconnect the gas supply connection before moving the oven.

When all cleaning and servicing is complete:

1. If the oven was moved for servicing, return the oven to its original location. Adjust the legs so that they are seated properly on the floor.
2. Reconnect the gas supply.
3. Reconnect the electrical supply.
4. Turn on the full-flow gas safety valve. Test the gas line connections for leaks using approved leak test substances or thick soap suds.
5. Turn on the electric supply circuit breaker(s).
6. Perform the normal startup procedure.

### WARNING

Possibility of injury from moving parts and electrical shock exists in this oven. Switch off and lockout/tagout the electric supply BEFORE beginning to disassemble, clean, or service any oven. Never disassemble or clean an oven with the BLOWER switch or any other circuit of the oven switched on.

### CAUTION

NEVER use a water hose or pressurized steam-cleaning equipment when cleaning this oven. DO NOT use excessive amounts of water, to avoid saturating the oven insulation. DO NOT use a caustic oven cleaner, which can damage the aluminized bake chamber surfaces.

### NOTE

ANY replacement parts that require access to the interior of the oven may ONLY be replaced by a Middleby Marshall Authorized Service Agent.

### NOTE

It is strongly recommended that the 3-Month Maintenance and 6-Month Maintenance procedures in this section be performed ONLY by a Middleby Marshall Authorized Service Agent.

## SECTION 4 MAINTENANCE

### I. MAINTENANCE - DAILY

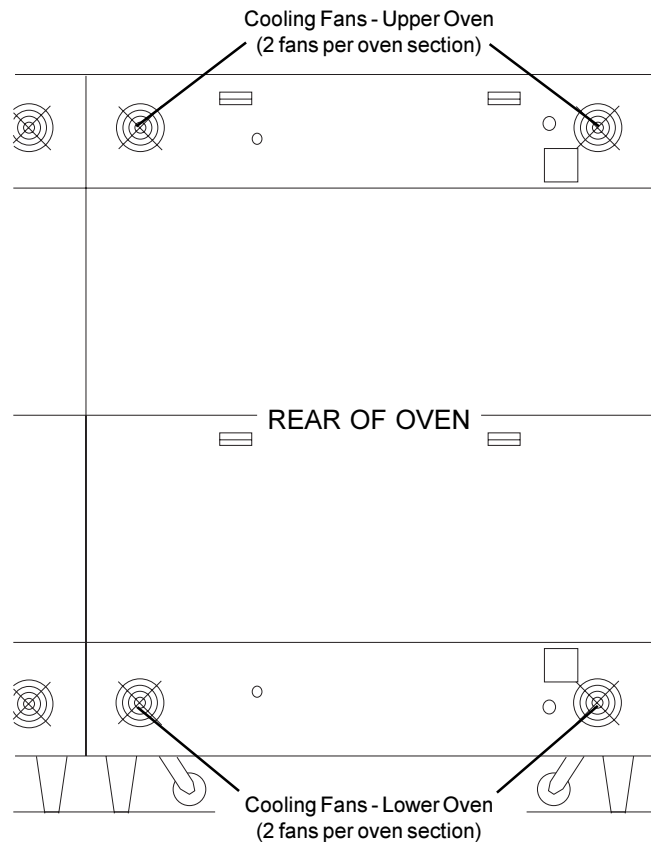
- A. Check that the oven is cool and the power is disconnected, as described in the warning on Page 4-1.
- B. Clean the outside of the oven with a soft cloth and mild detergent.
- B. Clean ALL of the cooling fan grills on the rear of the oven with a stiff nylon brush. Locations of the fans are shown in Figure 4-1.
- C. Check that ALL cooling fans are operating properly.

#### CAUTION

If a cooling fan is not operating correctly, it must be replaced IMMEDIATELY. Operating the oven without adequate cooling can seriously damage the oven's internal components.

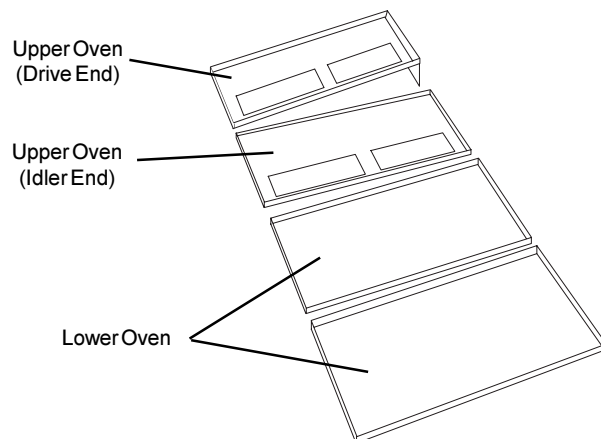
- D. Clean the conveyor belts with a stiff nylon brush. This is more easily accomplished by allowing the conveyor to run while you stand at the exit end of the conveyor. Then, brush the crumbs off the conveyor as it moves.

Figure 4-1 - Cooling Fan Locations



- E. TANDEM AND DOUBLE TANDEM OVENS ONLY: Remove and clean the crumb trays. Be sure to replace the trays in the same positions from which they were removed, because they are NOT identical. See Figure 4-2.
- F. OVENSEQUIPPED WITH WINDOWS ONLY: Clean the window in place.

Figure 4-2  
Crumb Pans



## II. MAINTENANCE - MONTHLY

- A. Check that the oven is cool and the power is disconnected, as described in the warning on Page 4-1.
- B. Remove the conveyor from the oven. (Pages 2-9 to 2-11 describe the installation of the conveyor; performing this procedure *in reverse* allows the conveyor to be removed.)
- C. Slide the air fingers and blank plates out of the oven, as shown in Figure 4-3. **AS EACH FINGER OR PLATE IS REMOVED, WRITE A "LOCATION CODE" ON IT WITH A MARKER** to make sure that it can be reinstalled correctly.

Example of markings:

(Top Row)     **T1 T2 T3 T4 T5 T6**

(Bottom Row) **B1 B2 B3 B4 B5 B6**

- D. **TRI TANDEM OVENS ONLY:** To remove the air fingers from the center section of the oven, the air finger retaining screws must be removed. See Figure 2-7 (Page 2-5).
- E. **QUAD TANDEM OVENS ONLY:** To remove the air fingers from the two center sections of the oven, the transition must be disassembled. (Pages 2-7 to 2-8, and Page 2-11, describe the assembly of the transition. Performing this procedure in reverse allows the transition to be disassembled.)
- F. Disassemble the air fingers as shown in Figure 4-4. **AS EACH FINGER IS DISASSEMBLED, WRITE THE "LOCATION CODE" FOR THE FINGER ON ALL THREE OF ITS PIECES.** This will help you in correctly reassembling the air fingers.

### CAUTION

Incorrect reassembly of the air fingers will change the baking properties of the oven.

- G. Clean the air finger components and the interior of the baking chamber using a vacuum cleaner and a damp cloth. Refer to the boxed warnings on Page 4-1 for cleaning precautions.
- H. Reassemble the air fingers. Then, replace them in the oven, using the "location code" as a guide.
- I. Reassemble the conveyor into the oven, and reattach the drive chain. Once again, refer to Pages 2-9 to 2-11 if necessary.
- J. Check the tension of the conveyor belt as shown in Figure 4-5. The belt should lift between 3-4" (75-100mm). **DO NOT OVERTIGHTEN THE CONVEYOR BELT.**

The belt tension can be adjusted by turning the conveyor adjustment screws, located at the idler end of the conveyor.

Figure 4-3 - Removing Fingers and Plates

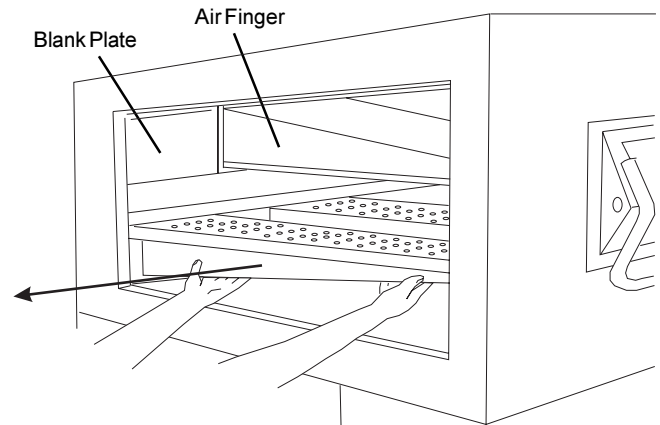


Figure 4-4 - Disassembling the Air Fingers

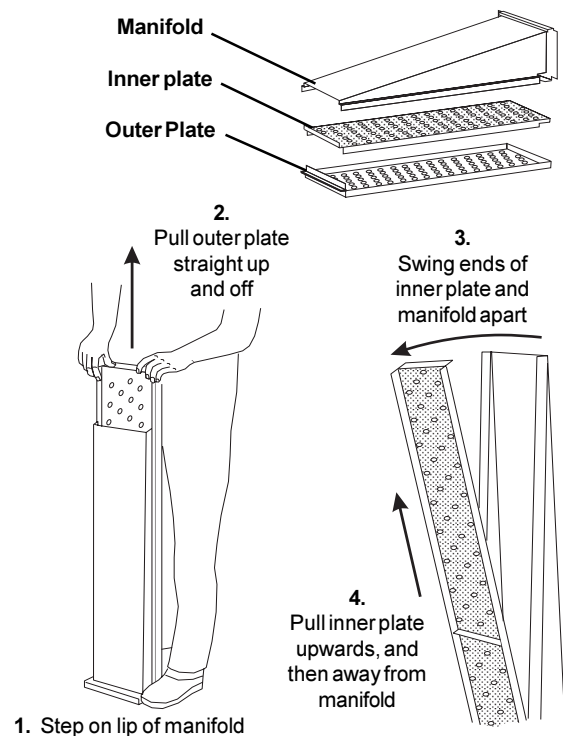
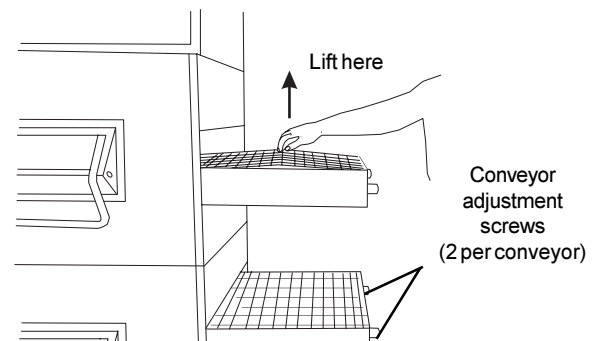


Figure 4-5 - Checking the Conveyor Belt Tension



SECTION 4  
MAINTENANCE

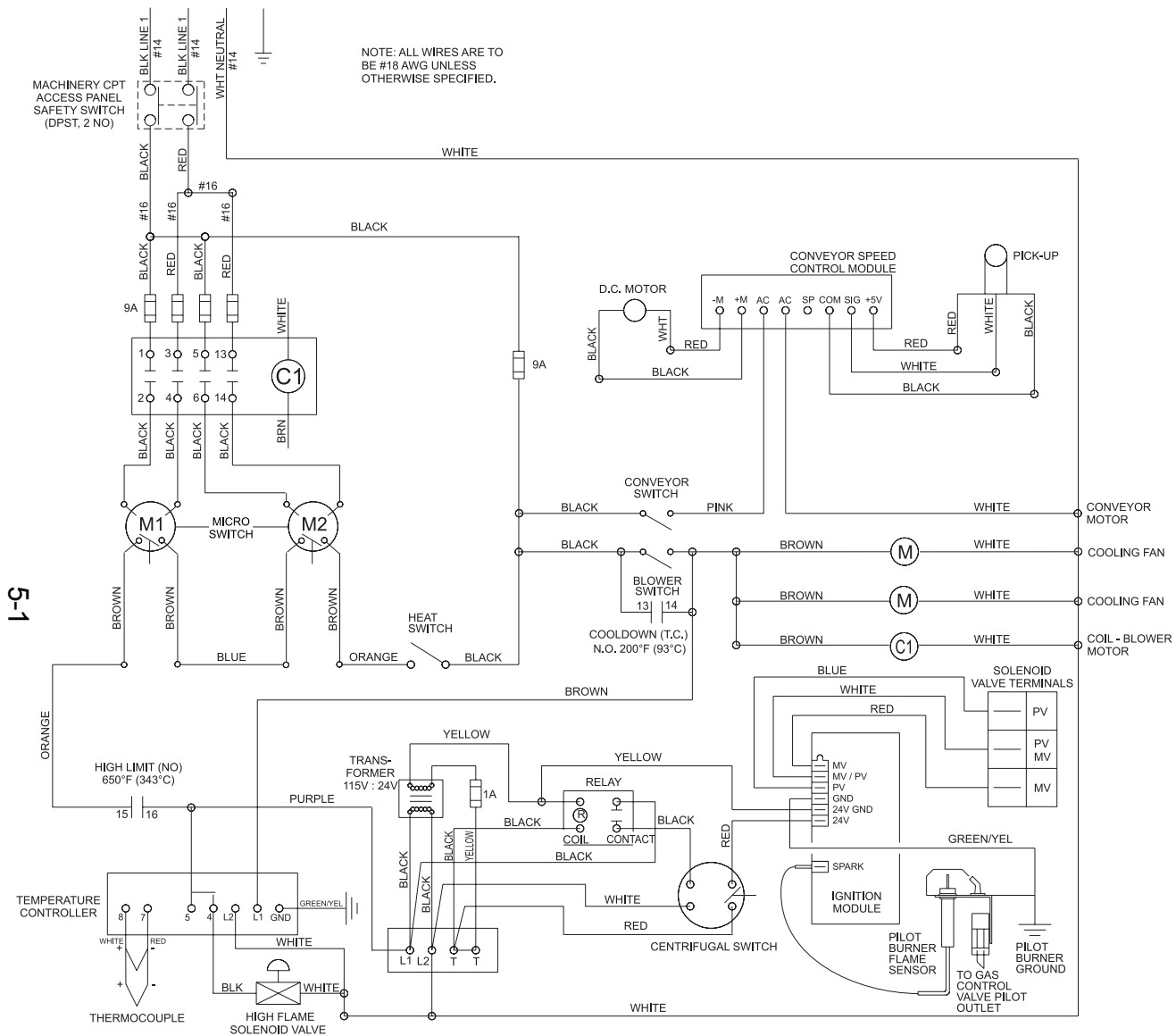
**III. MAINTENANCE - EVERY 3 MONTHS**

- A. Check that the oven is cool and the power is disconnected, as described in the warning on Page 4-1.
- B. Vacuum both of the blower motors, and their surrounding compartments, using a shop vacuum.
- C. Tighten all electrical control terminal screws.

**IV. MAINTENANCE - EVERY 6 MONTHS**

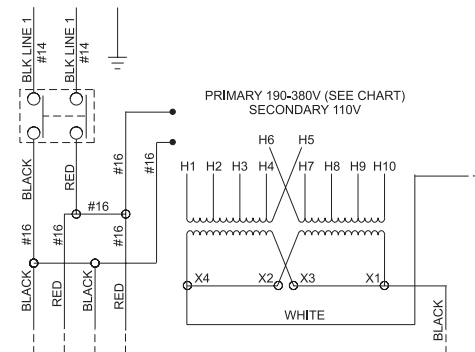
- A. Check that the oven is cool and the power is disconnected, as described in the warning on Page 4-1.
- B. Check for excessive wear on the conveyor drive motor brushes. The brushes should be replaced if they have worn to less than 1/4" (6.4mm) in length.
- C. Clean and inspect the burner nozzle and electrode assembly.
- D. Check (and clean, if necessary) the oven venting system, including the flue.
- E. TANDEM AND DOUBLE TANDEM OVENS ONLY: Check the conveyor drive shaft bushings and spacers. Replace the components if they are worn.
- F. TRI TANDEM AND QUAD TANDEM OVENS ONLY: Check the conveyor shaft bushings for wear. If necessary, lubricate the bearings.

**NOTES:**



5-1

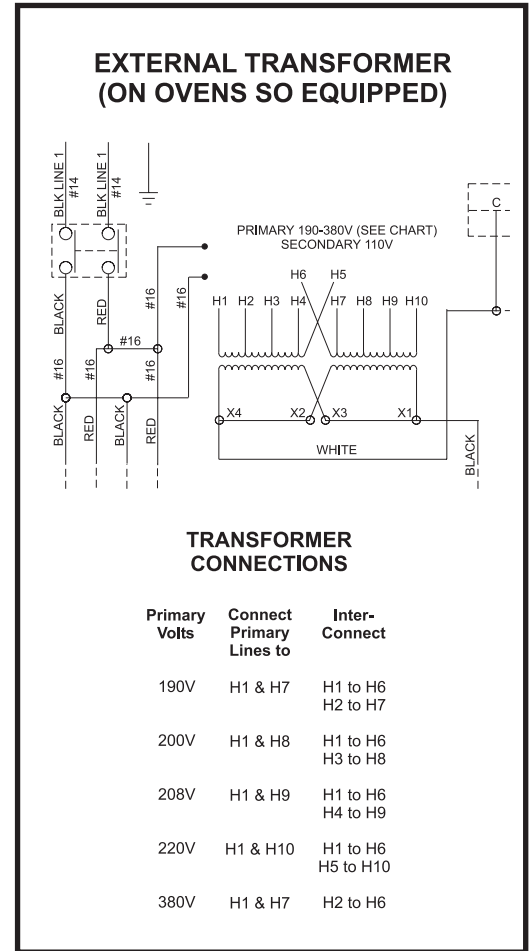
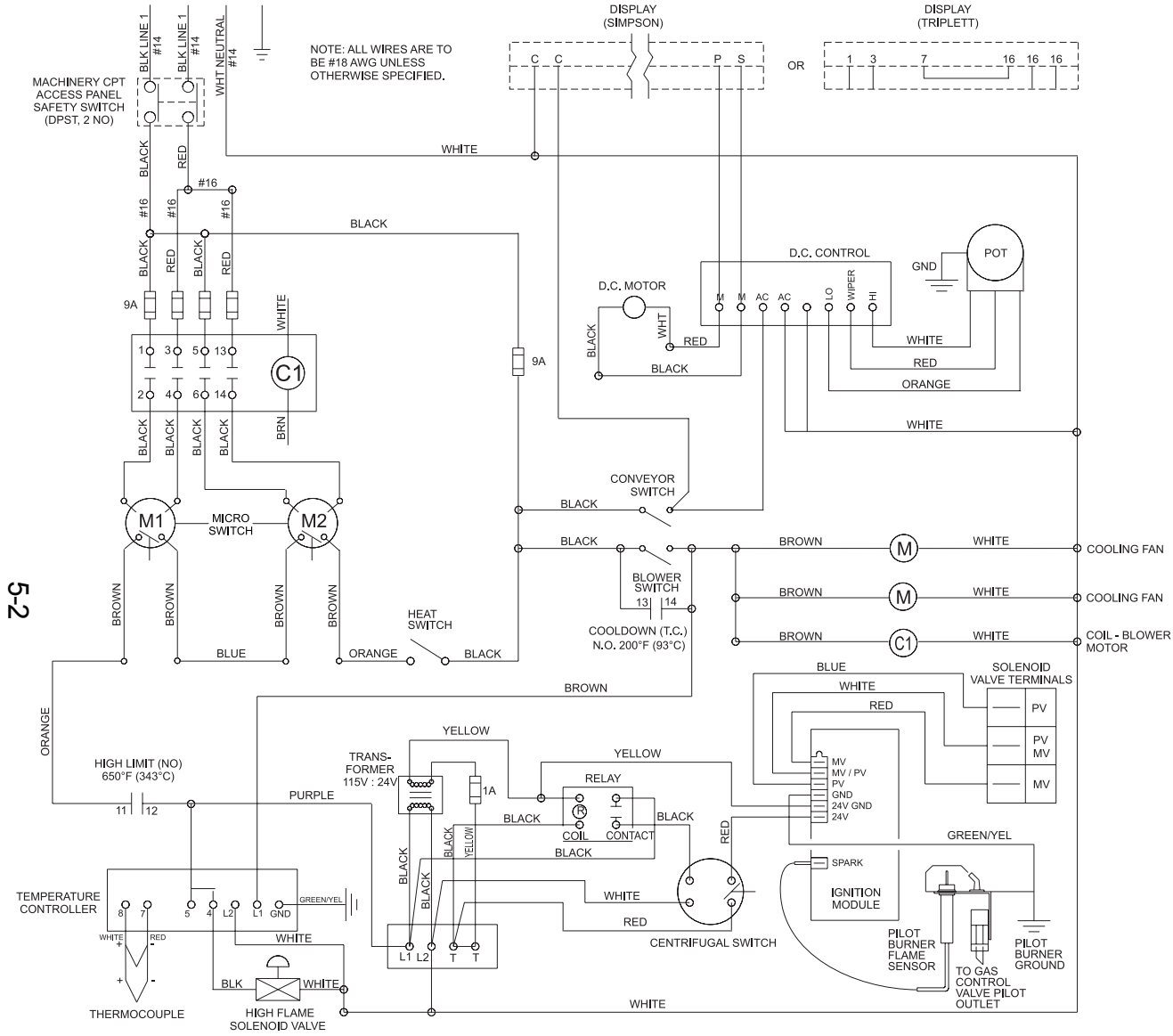
**EXTERNAL TRANSFORMER (ON OVENS SO EQUIPPED)**



**TRANSFORMER CONNECTIONS**

Primary Volts	Connect Primary Lines to	Inter-Connect
190V	H1 & H7	H1 to H6 H2 to H7
200V	H1 & H8	H1 to H6 H3 to H8
208V	H1 & H9	H1 to H6 H4 to H9
220V	H1 & H10	H1 to H6 H5 to H10
380V	H1 & H7	H2 to H6

**I. ELECTRICAL WIRING DIAGRAM PS360/PS360WB TANDEM AND DOUBLE TANDEM OVENS**



**II. ELECTRICAL WIRING DIAGRAM  
PS360/PS360WB TRI TANDEM AND QUAD TANDEM OVENS**

**NOTES:**



Middleby Cooking Systems Group • 1400 Toastmaster Drive • Elgin, IL 60120 • USA • (847)741-3300 • FAX (847)741-4406

***Middleby Corp 24-Hour Service Hotline 1-800-238-8444***

***[www.middleby.com](http://www.middleby.com)***