



**Middleby
Marshall**

A MIDDLEBY COMPANY

Red Lobster *operating & installation manual*

**MIDDLEBY™ SERIES
PS200-R68 OVENS**

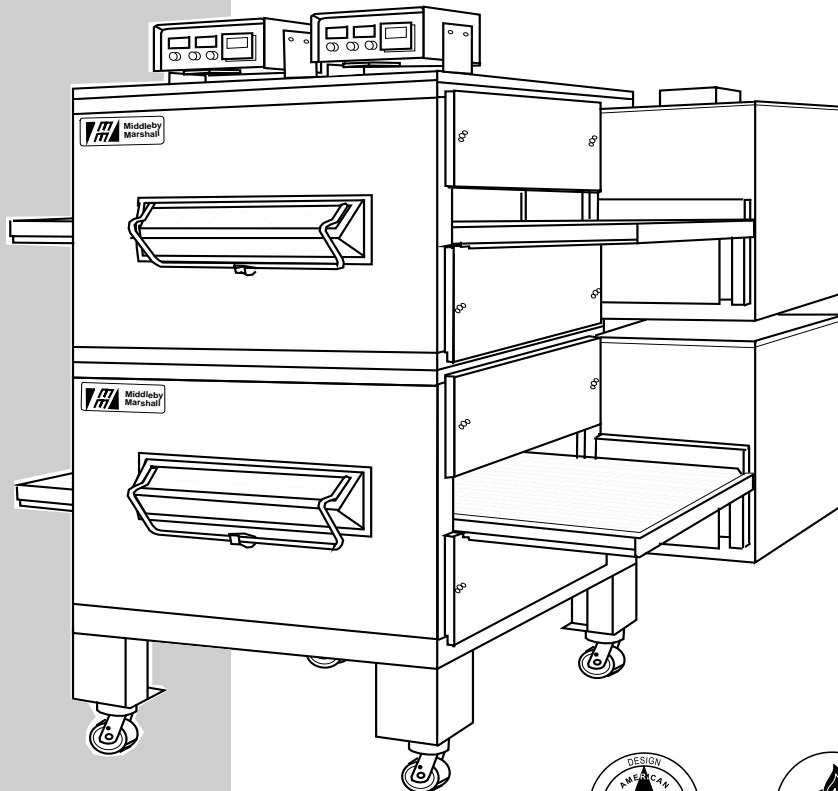

**MIDDLEBY MARSHALL INC.
NO QUIBBLE LIMITED WARRANTY
(U.S.A. ONLY)**

MIDDLEBY MARSHALL, HEREINAFTER REFERRED TO AS THE SELLER, WARRANTS EQUIPMENT MANUFACTURED BY IT TO BE FREE FROM DEFECTS IN MATERIAL AND WORKMANSHIP FOR WHICH IT IS RESPONSIBLE. THE SELLER'S OBLIGATION UNDER THIS WARRANTY SHALL BE LIMITED TO REPLACING OR REPAIRING AT SELLER'S OPTION, WITHOUT CHARGE, ANY PART FOUND TO BE DEFECTIVE AND ANY LABOR AND MATERIAL EXPENSE INCURRED BY SELLER IN REPAIRING OR REPLACING SUCH PART, SUCH WARRANTY SHALL BE LIMITED TO THE ORIGINAL PURCHASER ONLY AND SHALL BE EFFECTIVE FOR A PERIOD OF TWO YEARS FROM DATE OF ORIGINAL INSTALLATION, OR 30 MONTHS FROM DATE OF SHIPMENT, WHICHEVER IS EARLIER; PROVIDED THAT TERMS OF PAYMENT HAVE BEEN FULLY MET.

This warranty is valid only if the equipment is installed, started and demonstrated under the supervision of a factory certified installer.

Normal maintenance functions, including lubrication, cleaning or customer abuse are not covered by this no quibble warranty.

Seller shall be responsible only for repairs or replacements of defective parts performed by Seller's authorized service personnel. Authorized service agencies are located in principal cities throughout the contiguous United States, Alaska and Hawaii. This warranty is valid in the 50 United States and is void elsewhere unless the product is purchased through Middleby International with warranty included.

The foregoing warranty is exclusive and in lieu of all other warranties, expressed or implied. There are no implied warranties of merchantability or of fitness for a particular purpose.

The foregoing warranty shall be Seller's sole and exclusive obligation and Buyer's sole and exclusive remedy for any action including breach of contract or negligence. In no event shall Seller be liable for a sum in excess of the purchase price of the item. Seller shall not be liable for any prospective or lost profits of Buyer.

**This Manual Must Be Kept
For Future Reference**

WARNING

POST IN A PROMINENT LOCATION, THE EMERGENCY TELEPHONE NUMBER OF YOUR LOCAL GAS SUPPLIER AND INSTRUCTIONS TO BE FOLLOWED IN THE EVENT YOU SMELL GAS.
Instructions to be followed in the event the user smells gas shall be obtained by consulting the local gas supplier. If the smell of gas is detected, immediately call the emergency phone number of your local Gas Company. They will have personnel and provisions available to correct the problem.

**FOR YOUR SAFETY
DO NOT STORE OR USE GASOLINE
OR OTHER FLAMMABLE VAPORS AND LIQUIDS IN
THE VICINITY OF THIS OR ANY OTHER APPLIANCE**

WARNING

Improper installation, adjustment, alteration, service or maintenance can cause property damage, injury or death. Read the installation, operating and maintenance instructions thoroughly before installing or servicing this equipment.

NOTICE

CONTACT YOUR LOCAL SERVICE COMPANY TO PERFORM MAINTENANCE AND REPAIRS. A SERVICE AGENT DIRECTORY IS SUPPLIED IN YOUR INSTALLATION KIT.

NOTICE

Using any parts other than genuine Middleby Marshall factory manufactured parts relieves the manufacturer of all warranty and liability.

NOTICE

Middleby Marshall (Manufacturer) reserves the right to change specifications at any time.

WARNING

The equipment warranty is not valid unless the oven is installed, started and demonstrated under the supervision of a factory certified installer.

TABLE OF CONTENTS

	Page
SECTION 1 - DESCRIPTION	
I. MODEL IDENTIFICATION	1
OVEN SPECIFICATION CHART	2
ELECTRICAL SPECIFICATION CHART	3
II. PRINCIPLE OF AIR FLOW	4
A. Heat Transfer And How It Works	4
B. Air Fingers	5
III. COMPONENT FUNCTION	7
A. Conveyor	7
B. Fan	7
C. Gas Burner(Gas Oven Only)	7
D. Electric Heaters (Electric Ovens Only)	7
E. Front Window	7
F. Cooling Fan	7
G. Air Fingers	8
SECTION 2 - INSTALLATION	
I. UNLOADING	9
INSTALLATION KITS	10-12
DIMENSION DRAWING OF OVEN	13
II. CONTROL BOX AND CABLE INSTALLATION	14
III. FLUE VENT INSTALLATION	15
IV. RESTRAINT CABLE INSTALLATION	15
GAS OVEN ROUGH-IN	16
ELECTRIC OVEN ROUGH-IN	17
V. VENTILATION GUIDELINES	18
VI. ELECTRIC SUPPLY FOR GAS HEATED OVENS	19
VII. ELECTRICAL CONNECTION INFORMATION FOR ALL OVENS	19
VIII. ELECTRIC SUPPLY FOR ELECTRICALLY HEATED OVENS	20
IX. GAS SUPPLY FOR GAS HEATED OVENS	21
X. CONVEYOR BACKSTOP AND END STOP INSTALLATION	23
SECTION 3 - OPERATION	
I. CONTROLS AND COMPONENTS	25
II. COMPONENT INFORMATION AND LOCATION	26
A. Door Safety Switch	26
B. Blower Fan	26
C. Heat (Gas ovens only)	26
D. Temperature Controller	26
E. Heat (Electrically heated ovens only)	26
F. Conveyor	27
III. OPERATION	28
A. Start Up Procedures — Gas Heated Ovens	28
B. Temperature Controller Operation Instructions	30
C. Start Up Procedures — Electric Ovens	32
D. Shut Down (Gas or Electric Ovens)	33
E. Conveyor Speed (Bake Time) And Time Of Delivery	33

TABLE OF CONTENTS

Continued

SECTION 4 - MAINTENANCE

I. MAINTENANCE - DAILY	35
A. Exterior	35
B. Cooling Fan	35
C. Crumb Pans	36
II. MAINTENANCE - WEEKLY	36
A. Removing Conveyor From Oven For Cleaning	36
B. Oven Interior Disassembly	38
C. Window Disassembly For Cleaning	39
D. Loading The Soak Bin	39
E. Cleaning Parts That Were Soaked Overnight	41
F. Cleaning Interior of Oven	43
G. Oven Reassembly	44
III. MAINTENANCE - EVERY 3 MONTHS	50
A. Cleaning Fan Motor	50
B. Electrical Terminals	50
C. Checking and/or Replacing Main Blower Fan Belt	51
D. Main Blower Fan Shaft Bearing Lubrication	52
IV. MAINTENANCE - EVERY 6 MONTHS	53

SECTION 5 - TROUBLESHOOTING

OWNERS TROUBLESHOOTING CHARTS	55
-------------------------------------	----

SECTION 6 - PARTS LIST

Oven Panels, Window and Legs Exploded Drawing	60
Air Finger Exploded Drawing	62
Control Panel Exploded Drawing	64
Blower and Shroud Exploded Drawing	66
Conveyor Exploded Drawing	68
Gas Burner and Piping Assembly Exploded Drawing	70
Machinery Compartment Exploded Drawing	72
Electric Oven Electrical Panel Drawing	74
Junction Box and Export Transformer Exploded Drawing	76

SECTION 7 - ELECTRICAL SCHEMATICS

Gas Oven Schematic, 208-240V, 50/60Hz, 1Ph, 4W	80
Oven Control Box Cables	81

NOTES

SECTION 1 DESCRIPTION

I. MODEL IDENTIFICATION

The Middleby™ Series PS200-R68 Ovens may be used singly or stacked for use as double ovens.

The Series PS200-R68 single oven is mounted on a base pad with 6" extension legs and casters. A double oven is stacked and the lower oven is on a base pad with casters.

The ovens in a double oven operate completely independent of one another. Both ovens use identical controls and components. One can be serviced while the other is operating.

The Series PS200-R68 Ovens can be ordered with the conveyor drive at either the right end or left end of the oven. Each oven is equipped with a remote control box.

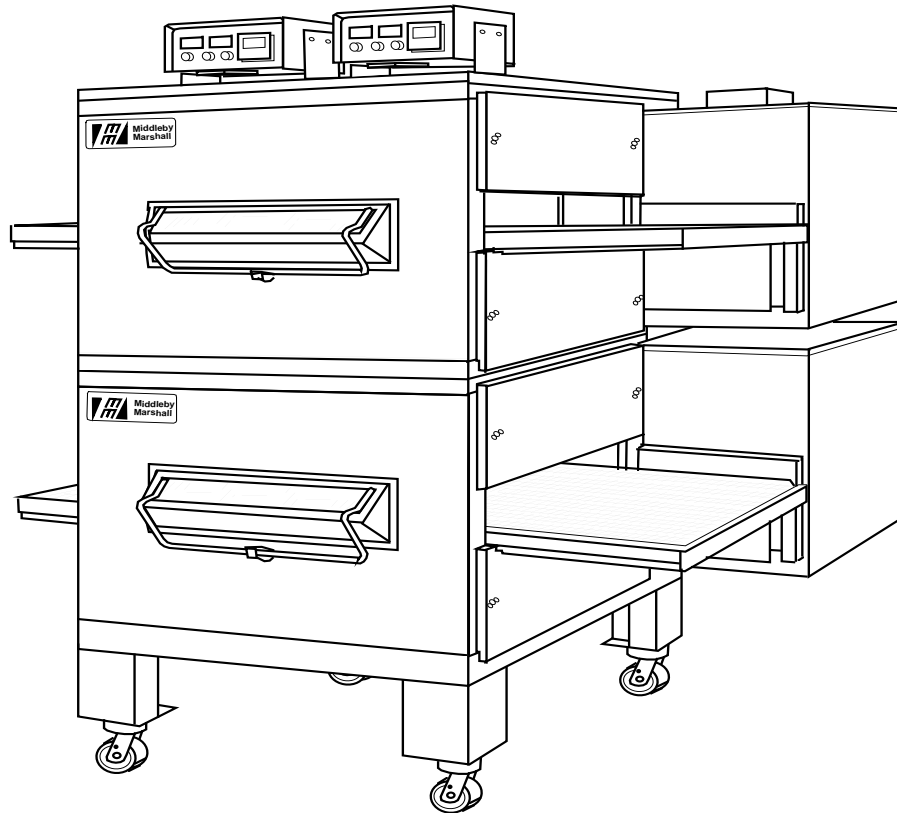

Figure 1-1. Middleby™ Series PS200-R68 Ovens

	PS200-R68 GAS	PS200-R68 ELECTRIC	PS224-R68 GAS	PS224-R68 ELECTRIC	PS220-R68 GAS	PS220-R68 ELECTRIC
Conveyor Belt Width	32"(813mm)	32"(813mm)	24"(610mm)	24"(610mm)	20"(508mm)	20"(508mm)
Heating Zone Length	40-1/2"(1028mm)	40-1/2"(1028mm)	40-1/2"(1028mm)	40-1/2"(1028mm)	40-1/2"(1028mm)	40-1/2"(1028mm)
Baking Area Square Feet	9 sq.ft.(0.84sq.m.)	9 sq.ft.(0.84sq.m.)	6.4 sq.ft.(0.59sq.m.)	6.4 sq.ft.(0.59sq.m.)	5.5 sq.ft.(0.51sq.m.)	5.5 sq.ft.(0.51sq.m.)
Overall Dimension Red Lobster Double Oven	68"(1727mm) L x 57-3/4"(1467mm) W x 76-3/4"(1949mm) H	68"(1727mm) L x 57-3/4"(1467mm) W x 76-3/4"(1949mm) H	68"(1727mm) L x 49-3/4"(1264mm) W x 76-3/4"(1949mm) H	68"(1727mm) L x 49-3/4"(1264mm) W x 76-3/4"(1949mm) H	68"(1727mm) L x 45-3/4"(1162mm) W x 76-3/4"(1949mm) H	68"(1727mm) L x 45-3/4"(1162mm) W x 76-3/4"(1949mm) H
Weight of Single Oven	925 lbs.(419kg)	925 lbs.(419kg)	825 lbs.(374kg)	825 lbs.(374kg)	750 lbs.(340kg)	750 lbs.(340kg)
Shipping Weight of Single Oven	1,100 lbs.(498.3kg)	1,100 lbs.(498.3kg)	1,000 lbs.(453kg)	1,000 lbs.(453kg)	925 lbs.(419kg)	925 lbs.(419kg)
Shipping Cube of Single Oven	Approx.132 ft³(3.74 m³)	Approx.132 ft³(3.74 m³)	Approx.132 ft³(3.74 m³)	Approx.132 ft³(3.74 m³)	Approx.132 ft³(3.74 m³)	Approx.132 ft³(3.74 m³)
Operating Range of Single Oven	120,000 BTU/HR (30,240 kcal) (35.1 kW/HR)	28kW/HR	100,000 BTU/HR (25,200 kcal) (29.3 kW/HR)	28kW/HR	100,000 BTU/HR (25,200 kcal) (29.3 kW/HR)	28kW/HR
Maximum Operating Temperature	550°F(287°C)	550°F(287°C)	550°F(287°C)	550°F(287°C)	550°F(287°C)	550°F(287°C)
Exhaust Vent Size	2" x 3"(50 x 75mm)	--	2" x 3"(50 x 75mm)	--	2" x 3"(50 x 75mm)	--
Exhaust Flow	80 C.F.M.(2.1m³m)	--	80 C.F.M.(2.1m³m)	--	80 C.F.M.(2.1m³m)	--
Warm Up Time	10 min.	15 min.	10 min.	15 min.	10 min.	15 min.
Gas Inlet Line Size	3/4"(19mm)ID for each cavity					
Minimum Gas Meter Rating	450 cu.ft./hr.(12.74m³h) for 1 to 2 cavities Add 180 cu.ft./hr.(5.1m³h)for each additional cavity					
Minimum Gas Pipe Size:	Natural	2" (51mm)ID for 1 or 2 ovens or 2.5" (64mm)ID for 3 or 4 ovens				
	Propane	1.5" (38mm)ID for 1 to 2 ovens or 2"(51mm)ID for 3 or 4 ovens - (must be dedicated line)				
Gas Pressure:	Natural	6"(152mm) to 14"(356mm) Water Column				
	Propane	11.5"(292mm) to 14"(356mm) Water Column				
Gas Valves	0.75" (19mm)ID full flow gas shut-off valve. A separate connection and valve must be provided for each cavity.					
Recirculating Air Blower	One blower at 1700 RPM					
Jet Air Velocity	3000 F.P.M.(1524cm/sec.)(Average)					
Bake Time	2 min. 40 sec. Bake Time minimum 29 min. 50 sec. Bake Time maximum					

**SERIES PS200-R68
ELECTRICAL SPECIFICATIONS**

GAS HEATED OVENS

Main Blower & Elements Voltage	Control Circuit Voltage	Phase	Frequency	Amperage Draw	Poles	Wires
208-240V	120V	1 Ph	50/60 Hz	4.1 Amp	3 Pole	4 Wire (2 hot, 1 neut, 1 grd)
208V Export	120V Transformer	1 Ph	50/60 Hz	4.1 Amp	2 Pole	3 Wire (2 hot, 1 grd)
200V Export	120V Transformer	1 Ph	50/60 Hz	4.1 Amp	2 Pole	3 Wire (2 hot, 1 grd)
220-240V Export	120V Transformer	1 Ph	50/60 Hz	4.1 Amp	2 Pole	3 Wire (2 hot, 1 grd)

ELECTRIC HEATED OVENS

Main Blower & Elements Voltage	Control Circuit Voltage	Phase	Frequency	Amperage Draw	Poles	Wires																														
208-240V	120V	3 Ph	50/60 Hz	75 Amp	4 Pole	5 Wire (3 hot, 1 neut, 1 grd)																														
HEATER AMPERAGE																																				
<table border="1"> <thead> <tr> <th>Voltage</th> <th>kW</th> <th>Amp</th> <th colspan="3">Average Amps</th> </tr> </thead> <tbody> <tr> <td>208</td> <td>27</td> <td>70</td> <td>37</td> <td>37</td> <td>37</td> </tr> <tr> <td>220</td> <td>23.5</td> <td>67</td> <td>30</td> <td>30</td> <td>30</td> </tr> <tr> <td>230</td> <td>25.7</td> <td>63</td> <td>31</td> <td>31</td> <td>31</td> </tr> <tr> <td>240</td> <td>27</td> <td>61</td> <td>33</td> <td>33</td> <td>33</td> </tr> </tbody> </table>							Voltage	kW	Amp	Average Amps			208	27	70	37	37	37	220	23.5	67	30	30	30	230	25.7	63	31	31	31	240	27	61	33	33	33
Voltage	kW	Amp	Average Amps																																	
208	27	70	37	37	37																															
220	23.5	67	30	30	30																															
230	25.7	63	31	31	31																															
240	27	61	33	33	33																															
220-240V	120V Transformer	3 Ph	50/60 Hz	75 Amp	3 Pole	4 Wire (3 hot, 1 grd)																														
HEATER AMPERAGE																																				
<table border="1"> <thead> <tr> <th>Voltage</th> <th>kW</th> <th>Amp</th> <th colspan="3">Average Amps</th> </tr> </thead> <tbody> <tr> <td>220</td> <td>23.5</td> <td>67</td> <td>30</td> <td>30</td> <td>30</td> </tr> <tr> <td>240</td> <td>27</td> <td>61</td> <td>33</td> <td>33</td> <td>33</td> </tr> </tbody> </table>							Voltage	kW	Amp	Average Amps			220	23.5	67	30	30	30	240	27	61	33	33	33												
Voltage	kW	Amp	Average Amps																																	
220	23.5	67	30	30	30																															
240	27	61	33	33	33																															
380V Export	120V Transformer	3 Ph	50/60 Hz	50 Amp	4 Pole	5 Wire (3 hot, 1 neut, 1 grd)																														
HEATER AMPERAGE																																				
<table border="1"> <thead> <tr> <th>Voltage</th> <th>kW</th> <th>Amp</th> <th colspan="3">Average Amps</th> </tr> </thead> <tbody> <tr> <td>380</td> <td>27</td> <td>38</td> <td>22</td> <td>22</td> <td>22</td> </tr> </tbody> </table>							Voltage	kW	Amp	Average Amps			380	27	38	22	22	22																		
Voltage	kW	Amp	Average Amps																																	
380	27	38	22	22	22																															
400-416V Export	120V Transformer	3 Ph	50/60 Hz	50 Amp	4 Pole	5 Wire (3 hot, 1 neut, 1 grd)																														
HEATER AMPERAGE																																				
<table border="1"> <thead> <tr> <th>Voltage</th> <th>kW</th> <th>Amp</th> <th colspan="3">Average Amps</th> </tr> </thead> <tbody> <tr> <td>415</td> <td>27</td> <td>35</td> <td>28</td> <td>28</td> <td>28</td> </tr> </tbody> </table>							Voltage	kW	Amp	Average Amps			415	27	35	28	28	28																		
Voltage	kW	Amp	Average Amps																																	
415	27	35	28	28	28																															

NOTE
Wiring Diagram is contained at the back of this Manual and is also located inside of the machinery compartment.

SECTION 1 DESCRIPTION

II. PRINCIPLE OF AIR FLOW

Air is heated and then pulled through the fan which pushes the air into the oven plenum and delivers heated air into the air fingers. The fingers contain an inner plate and outer plate which columnate the air and evenly distribute heated air across the conveyor belt on which the product rides. Air is then pulled back into the blower and the process continues.

A. Heat Transfer and How It Works

1. Heat constantly moves from a warm object to a cold object. Heat moves using three different paths which are conduction, radiation and convection.

Conduction: This path utilizes surface to surface contact. The pizza dough in contact with the pan is a good example of conduction.

Radiation: This path has to do with objects radiating heat. Dark objects absorb heat whereas light or shiny objects reflect more heat. This is the reason that the

inside of the Middleby Series PS200-R68 Oven is light in color to reflect more heat back to the product.

Convection: This path has to do with moving amounts of air. It explains why hot air will rise and cooler air replaces hot air. An industrial application of this principle is to incorporate a fan to force the hot air movement which in turn will increase the heat transfer to the product.

The Middleby Series PS200-R68 Oven has a large fan to move the hot air through the air fingers and onto the product so the most efficient bake is achieved.

2. Temperature is the intensity of heat at the point which it is sensed. As discussed above, heat flows by conduction, radiation and convection. The speed at which the heat flows is determined by the temperature difference between the oven and the food product. The larger the difference the faster the heat flows to the item that is being baked.

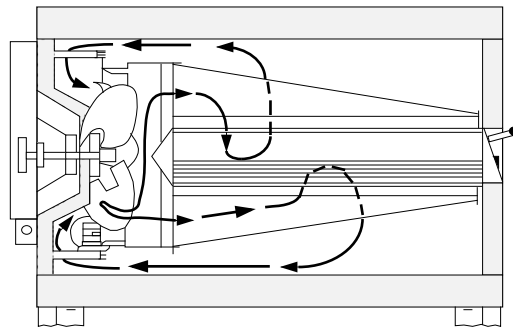

Side View

Figure 1-2
Series PS200-R68 Air Flow

II. PRINCIPLE OF AIR FLOW Continued

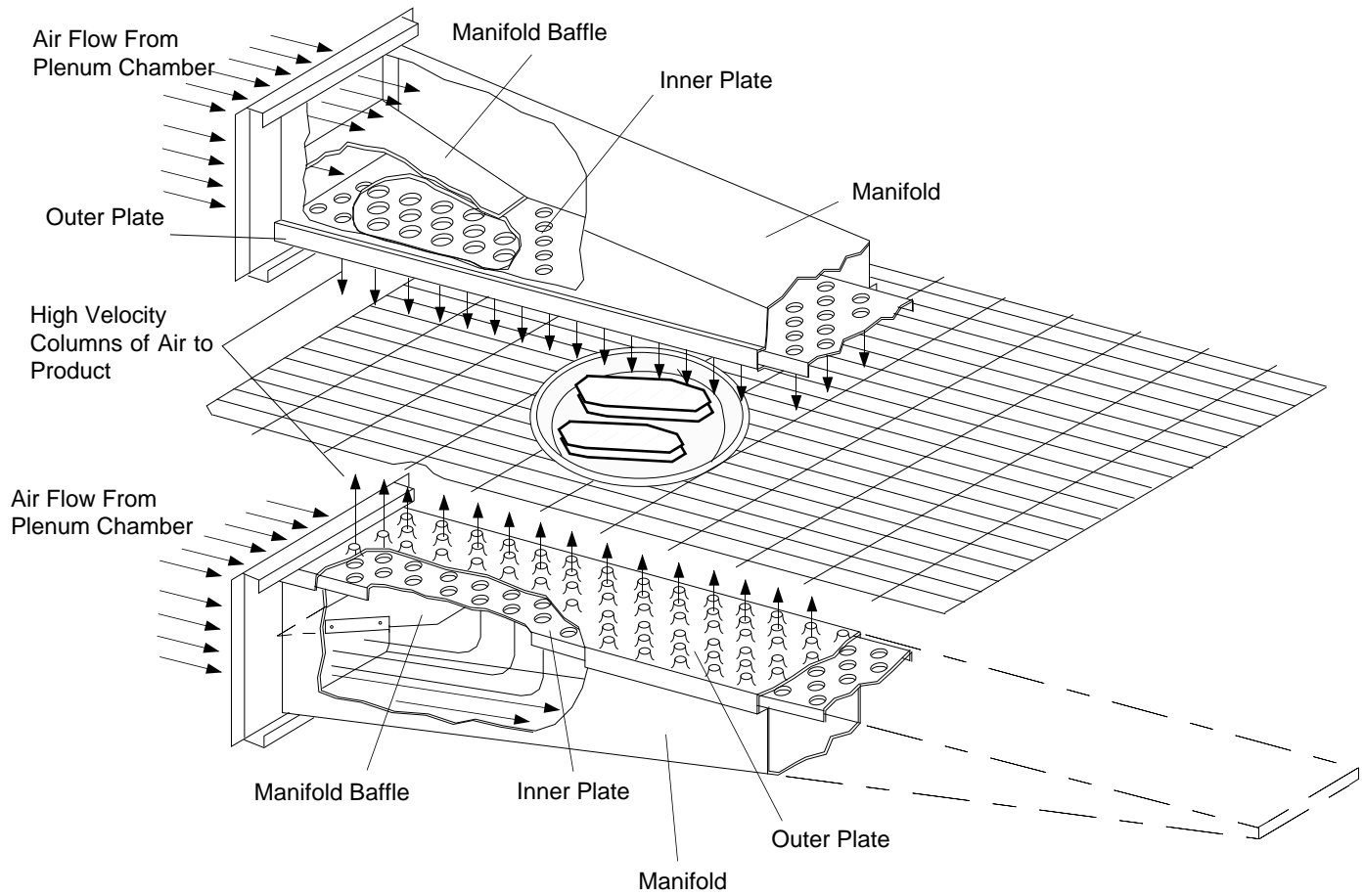

Figure 1-3. Air Fingers Showing Air Passing Through Inner Plate And Outer Plate Which Forms High Velocity Columns Of Air To The Product.

B. Air Fingers

The Middleby Series PS200-R68 Oven is a conveyerized hot air oven employing vertical air streams (Figure 1-3) to give uniform and intensive heating. The columnated vertical streams of hot air provide an exceptional heat transfer rate and generally bake faster and at lower temperatures than convection hot air or infrared heating ovens.

This is accomplished with use of hot air fingers inside the oven. The oven can accommodate up to 4 bottom air fingers and 4 top air fingers. Standard PS200-R68 Series ovens have 4 bottom fingers and 2 top fingers.

SECTION 1
DESCRIPTION

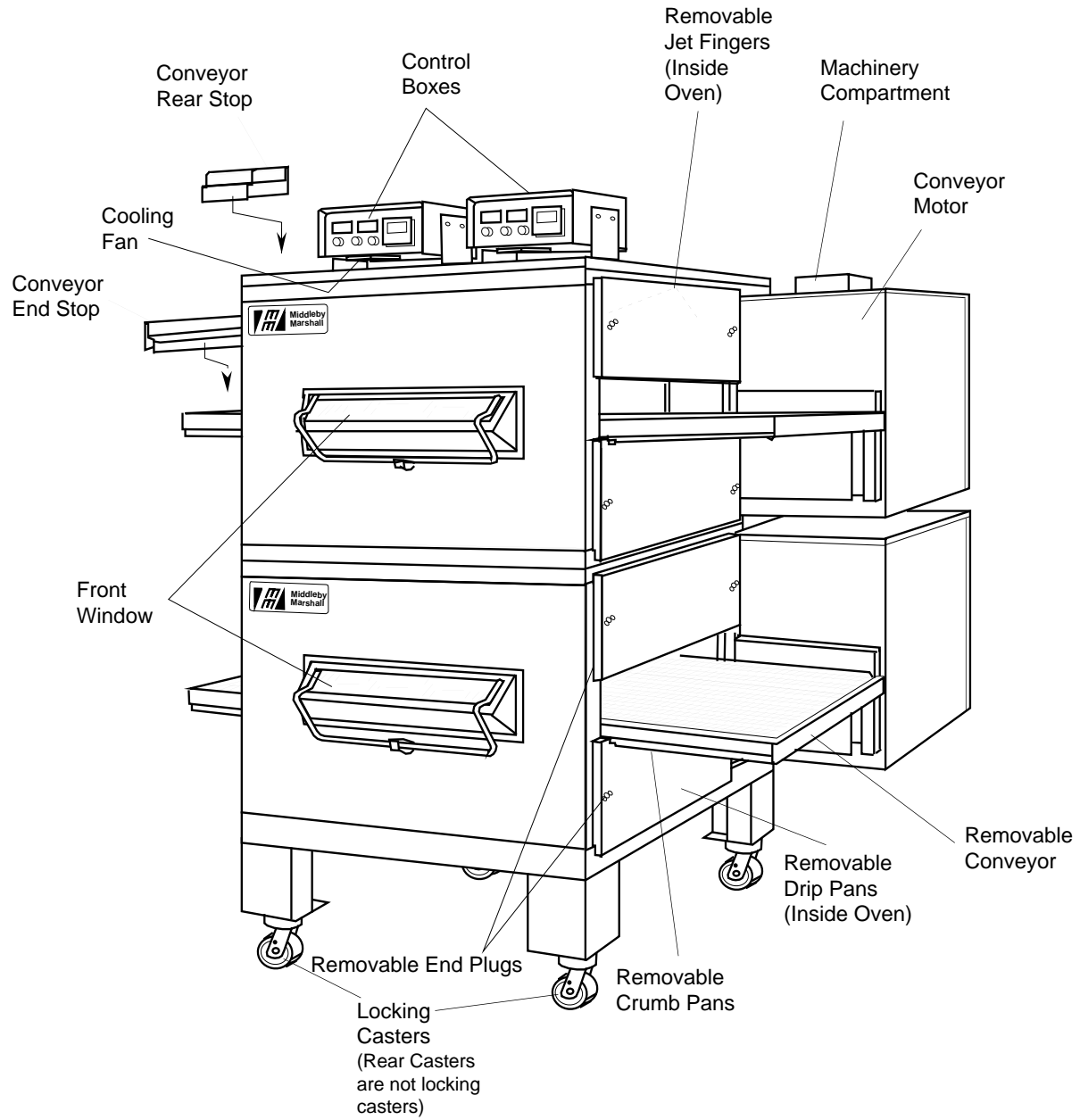

Figure 1-4. Component Location

III. COMPONENT FUNCTION

A. Conveyor

The conveyor is driven by a variable speed electric motor operating through a gear reducer (See Figure 1-5). The motor speed is controlled by a digital control. The stainless steel wire belt can travel in either direction and at variable speeds from 3 minutes to 23 minutes.

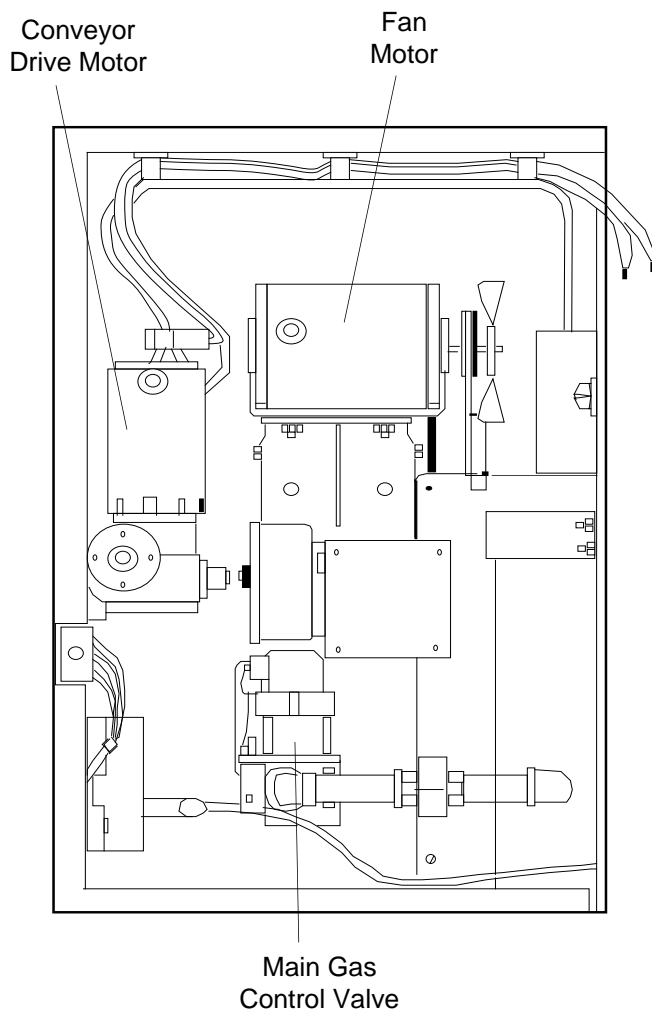

Figure 1-5. Conveyor Drive Motor

B. Fan

The fan is located at the rear of the oven. This fan forces heated air through the fingers. The fan switch has two positions and must be "on" for oven warm up and bake and for the conveyor to run.

C. Gas Burner (Gas Oven Only)

With the heat and blower switches ON the gas burner heats the air as the air enters the main blowers to maintain the set temperature. The burner flame is ignited and monitored by a solid state burner control device.

Should a flame outage occur the control will close the main gas control valve within 0.8 seconds and attempt to reignite the pilot.

D. Electric Heaters (Electric Oven Only)

There are six heater elements mounted on the inside of the rear panel. Each element is connected to a separate electrical contact which is energized by the temperature controller.

E. Front Window

The front window is used for viewing items being baked and provides access to the oven for items which do not require full bake time, such as sandwiches, cookies, small items or cheese melting processes.

F. Cooling Fan

A cooling fan is located in the back of the oven. This cooling fan blows cool air in through the machinery compartment across the fan motor and conveyor motor and control cabinet. The air is then exhausted through the side of the cabinet and also out the back of the oven compartment. Refer to Figure 1-6.

Another cooling fan is located in the bottom of each control box. Air is drawn in through the louvers in the rear of the control box and out through the fan. Refer to Figure 1-4.

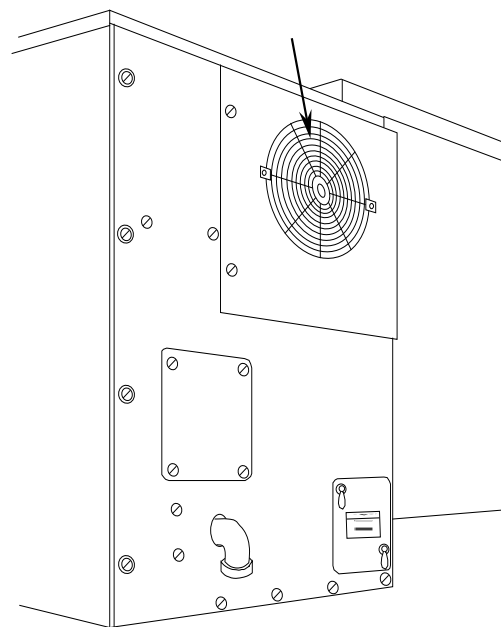

Figure 1-6. Cooling Fan

SECTION 1 DESCRIPTION

G. Air Fingers

The Air Finger Assemblies are made up of three parts as follows (See Figure 1-7):

1. **Outer Plate** - The Outer Plate is the removable cover with tapered holes, which directs the air stream onto the product to be baked.
2. **Inner Plate** - The Inner Plate is vital to forming the columnated air jets. It must be assembled onto the

manifold with its holes lined up with outer plate holes.

The inner plate is also manufactured with no rows of holes. This type of finger is a non-columnating air finger.

3. **Manifold** - The Manifold is the assembly which slides on tracks into the oven plenum.

4. **Blank Plates** - The Blank Plates are installed on the plenum where air fingers are not required.

NOTE: On a PS200-R68 Series Red Lobster oven the 2 upper fingers (M3) have 3 rows of holes in the outer plate and a non-columnating inner plate. The 4 bottom fingers (M6) have 6 rows of holes completely across the inner and outer plates.

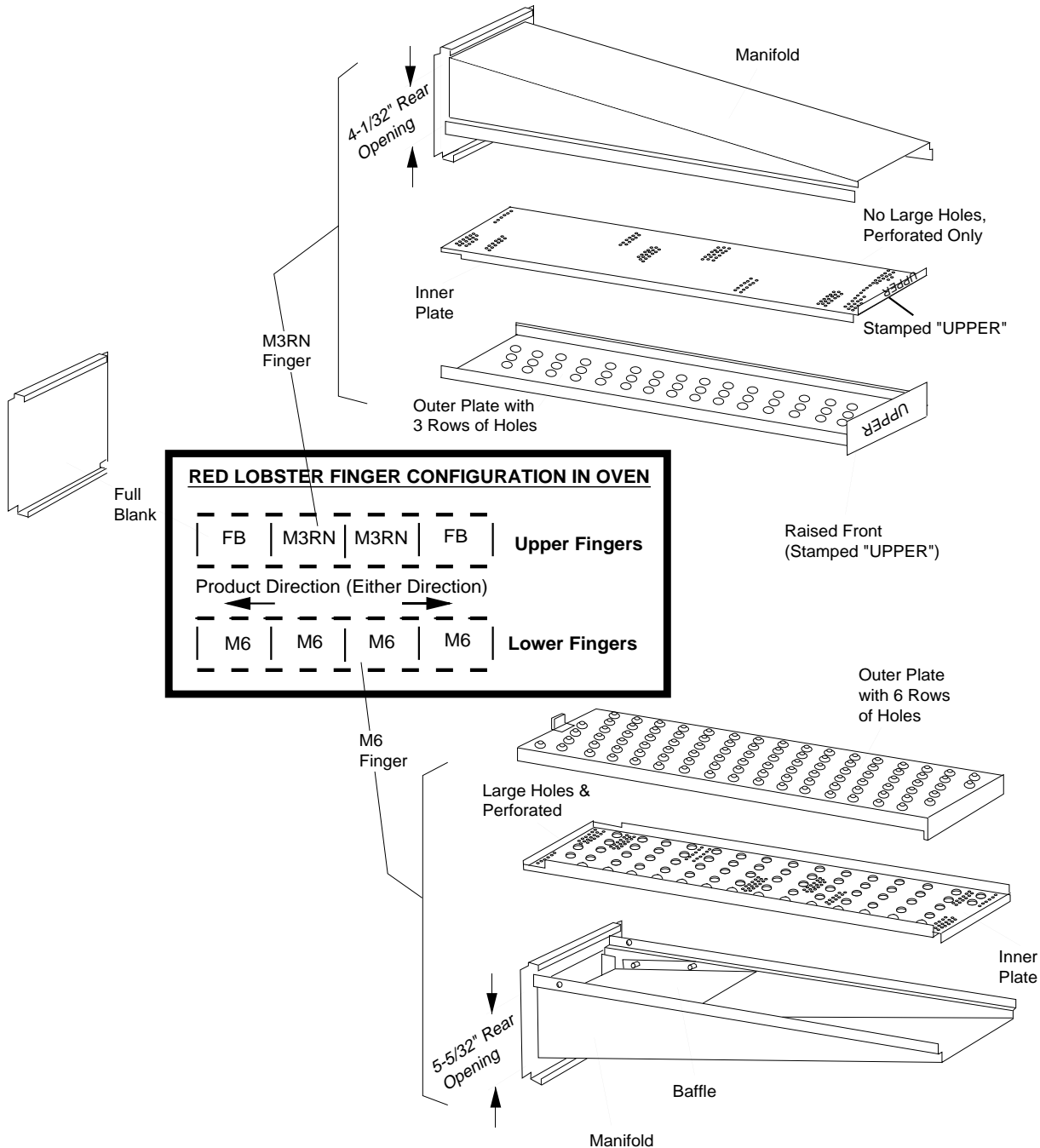

Figure 1-7. Fingers

SECTION 2 **INSTALLATION**

NOTE: For U.S. installations the installation must conform with local codes or in absence of local codes, with ANSI Z223.1-latest edition and electrical code ANSI/NFPA No. 70-latest edition.

NOTE: For Canadian Installations - The installation should be done in accordance with the CAN 1-B149.1 or .2 installation code and/or local code and the Canadian electrical code, Part 1, CGA C22.1 for the electrical features.

I. UNLOADING

Your Middleby Marshall Series PS200-R68 Oven(s) is shipped partially assembled and it will arrive in a carton.

Carton size for all Series 200-R68 Ovens is:

84" (2134mm) Long x
58" (1473mm) Wide x
44" (1118mm) High.

A Pre-installation Procedures Manual (MM P/N 88910-0009) is attached to the exterior wall of the carton. This manual contains detailed instructions on unpacking and moving the oven(s) into your facility. When your common carrier or truck line notifies you of delivery, you must have a forklift at the facility to unload the carton(s).

Instructions for stacking the ovens are contained in a separate manual issued to Middleby Marshall Certified Installers.

If you have a door wider than the carton simply move the carton into your facility and set up an appointment with your Certified Middleby Marshall Installer.

If your door is narrower than the carton, then the oven will have to be uncrated. Follow directions shown in the Pre-Installation Procedures Manual.

Each crate must be examined before signing the Bill of Lading. Report any visible damage caused by the trucker in transit, and check for the proper number of crates. If apparent damage is found, arrangements should be made to file a claim against the carrier. Interstate Commerce Regulations require that the claim must be initiated by the consignee within 10 days from the date it is received.

NOTE

There Must Be Adequate Clearance Between Oven And Combustible Construction. Clearance Must Also Be Provided For Servicing And For Operation.

CAUTION: It is required that the oven be placed under a ventilation hood for adequate air supply and ventilation.

CAUTION: A minimum clearance of 0" from non-drive end of oven to wall, 18" from drive end of oven to wall and 6" from rear wall to air openings at rear of unit must be maintained. For servicing and cleaning a minimum of 18" clearance from all walls and combustible materials is recommended.

CAUTION: Do not obstruct the flow of combustion and ventilation air to and from your oven. Do not obstruct the ventilation holes in the control panel, as these provide the combustion air for the burner.

SECTION 2
INSTALLATION

**PS200-R68 OVEN INSTALLATION
REQUIRED KITS AND EQUIPMENT**

TYPE OF INSTALLATION	KITS AND EQUIPMENT			
	PS200-R68 Gas Oven Installation Kit P/N 31350	PS200-R68 Electric Oven Installation Kit P/N 31514	PS200-R68 Single Oven Option Kit P/N 49025-0007	PS200-R68 Double Oven Option Kit P/N 31361
PS200-R68 Single Gas Oven	1		1	
PS200-R68 Single Electric Oven		1	1	
PS200-R68 Double Gas Oven	2			1
PS200-R68 Double Electric Oven		2		1

**PS220-R68 OVEN INSTALLATION
REQUIRED KITS AND EQUIPMENT**

	KITS AND EQUIPMENT			
	PS220-R68 Gas Oven Installation Kit P/N 31352	PS220-R68 Electric Oven Installation Kit P/N 31517	PS220-R68 Single Oven Option Kit P/N 30752	PS220-R68 Double Oven Option Kit P/N 31363
PS220-R68 Single Gas Oven	1		1	
PS220-R68 Single Electric Oven		1	1	
PS220-R68 Double Gas Oven	2			1
PS220-R68 Double Electric Oven		2		1

**PS224-R68 OVEN INSTALLATION
REQUIRED KITS AND EQUIPMENT**

	KITS AND EQUIPMENT			
	PS224-R68 Gas Oven Installation Kit P/N 31351	PS224-R68 Electric Oven Installation Kit P/N 31516	PS224-R68 Single Oven Option Kit P/N 49025-0016	PS224-R68 Double Oven Option Kit P/N 31362
PS224-R68 Single Gas Oven	1		1	
PS224-R68 Single Electric Oven		1	1	
PS224-R68 Double Gas Oven	2			1
PS224-R68 Double Electric Oven		2		1

**PARTS LIST FOR SERIES PS200-R68 GAS OVEN
INSTALLATION KIT
PS200-R68, P/N 31350
PS220-R68, P/N 31352
PS224-R68, P/N 31351**

(Two required for double oven)

ITEM NO.	QTY	PS200-R68 PART NO.	PS220-R68 PART NO.	PS224-R68 PART NO.	DESCRIPTION
1	1	22361-0005	22361-0005	22361-0005	FLEXIBLE GAS HOSE, 72"
2	1	23115-0010	23115-0010	23115-0010	3/4" GAS SHUTOFF VALVE
3	1	31006	30849	30851	CONVEYOR END STOP
4	1	30830	30830	30830	CONVEYOR LEFT REAR STOP
5	1	30796	30796	30796	CONVEYOR RIGHT REAR STOP
6	1	88910-0008	88910-0008	88910-0008	SERIES PS200-R68 OWNER/OPERATOR MANUAL
7	1	1002040	1002040	1002040	SERVICE STATION DIRECTORY
8	1	33900-0032	33900-0081	33900-0035	CONVEYOR WIRE BELT
9	1	42400-0089	49400-0090	49400-0197	MASTER LINK KIT
10	1	23125-0002	23125-0002	23125-0002	ELBOW 90° BLK REDUCER 1/2" X 3/4"
11	1	23153-0005	23153-0005	23153-0005	NIPPLE BLK 3/4 CLOSE
12	1	31315	31315	31315	PIPE, 31", UPPER OVEN
13	1	31238	31238	31238	NIPPLE BLK 1/2" X 4"

**PARTS LIST FOR SERIES PS200-R68 ELECTRIC OVEN
INSTALLATION KIT
PS200-R68, P/N 31514
PS220-R68, P/N 31517
PS224-R68, P/N 31516**

(Two required for double oven)

ITEM NO.	QTY	PS200-R68 PART NO.	PS220-R68 PART NO.	PS224-R68 PART NO.	DESCRIPTION
3	1	31006	30849	30851	CONVEYOR END STOP
4	1	30830	30830	30830	CONVEYOR LEFT REAR STOP
5	1	30796	30796	30796	CONVEYOR RIGHT REAR STOP
6	1	88910-0008	88910-0008	88910-0008	SERIES PS200-R68 OWNER/OPERATOR MANUAL
7	1	1002040	1002040	1002040	SERVICE STATION DIRECTORY
8	1	33900-0032	33900-0081	33900-0035	CONVEYOR WIRE BELT
9	1	42400-0089	49400-0090	49400-0197	MASTER LINK KIT

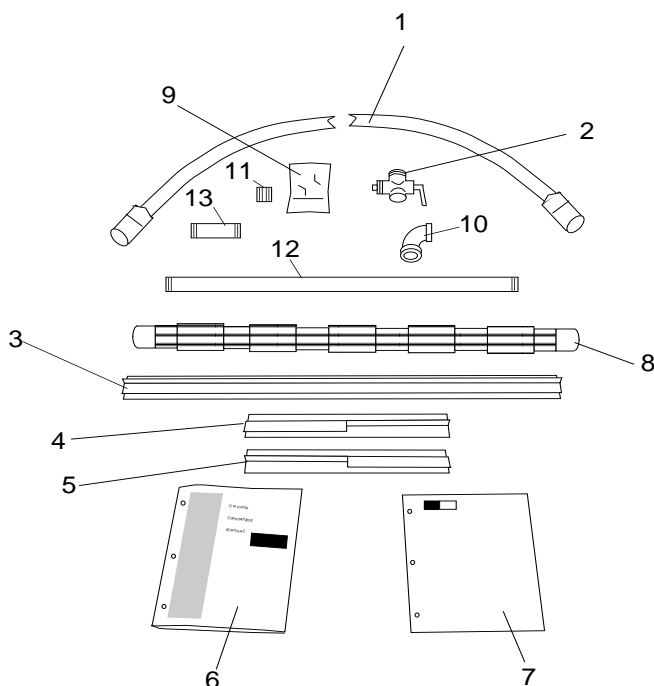

**Figure 2-1.
Series PS200-R68 Gas & Electric Oven
Installation Kits**

SECTION 2
INSTALLATION

PARTS LIST FOR SERIES PS200-R68 SINGLE OVEN OPTION KIT

PS200-R68, P/N 31360

PS220-R68, P/N 30752

PS224-R68, P/N 49025-0016

ITEM NO.	QTY	PS200-R68 PART NO.	PS220-R68 PART NO.	PS224-R68 PART NO.	DESCRIPTION
1	1	35900-0055	37900-0184	35900-0411	BASE PAD
2	4	37900-0102	37900-0102	37900-0102	LEGS
3	2	22290-0009	22290-0009	22290-0009	SWIVEL CASTER W/LOCKING BRAKE
4	2	22290-0010	22290-0010	22290-0010	SWIVEL CASTER
5	32	A11039	A11039	A11039	3/8" LOCKWASHER
6	32	21416-0001	21416-0001	21416-0001	3/8" FLAT WASHER
7	32	220373	220373	220373	3/8 - 16 SCREW HEX HD SS
8	4	21256-0008	21256-0008	21256-0008	SCREWS FOR TOP 10-32 X 3/8" RH
9	32	21296-0005	21296-0005	21296-0005	10-32 X 3/4" SCREW HEX WASHER HD SS
10	1	22450-0228	22450-0228	22450-0228	RESTRAINT CABLE ASSEMBLY
13	1	31319	31319	31319	LABEL, UPPER
14	1	31320	31320	31320	LABEL, LOWER
15	1	32116	32116	32116	WIREWAY ASSEMBLY
16	2	21516-0001	21516-0001	21516-0001	POP RIVETS
17	1	32227	32227	32227	INSTRUCTION, CONTROL BOX INSTALLATION
Not shown	1	32023	31261	30878	OVEN TOP

PARTS LIST FOR SERIES PS200-R68 DOUBLE OVEN OPTION KIT

PS200-R68, P/N 31361

PS220-R68, P/N 31363

PS224-R68, P/N 31362

ITEM NO.	QTY	PS200-R68 PART NO.	PS220-R68 PART NO.	PS224-R68 PART NO.	DESCRIPTION
1	1	35900-0055	37900-0184	35900-0411	BASE PAD
2	4	37900-0102	37900-0102	37900-0102	LEGS
3	2	22290-0009	22290-0009	22290-0009	SWIVEL CASTER W/LOCKING BRAKE
4	2	22290-0010	22290-0010	22290-0010	SWIVEL CASTER
5	32	A11039	A11039	A11039	3/8" LOCKWASHER
6	32	21416-0001	21416-0001	21416-0001	3/8" FLAT WASHER
7	32	220373	220373	220373	3/8 - 16 SCREW HEX HD SS
8	4	21256-0008	21256-0008	21256-0008	SCREWS FOR TOP 10-32 X 3/8" RH
9	32	21296-0005	21296-0005	21296-0005	10-32 X 3/4" SCREW HEX WASHER HD SS
10	1	22450-0228	22450-0228	22450-0228	RESTRAINT CABLE ASSEMBLY
11	1	30042	30042	30042	VENT EXTENSION
12	1	30039	30039	30039	OFFSET CROSSOVER VENT
13	1	31319	31319	31319	LABEL, UPPER
14	1	31320	31320	31320	LABEL, LOWER
15	1	32116	32116	32116	WIREWAY ASSEMBLY
16	2	21516-0001	21516-0001	21516-0001	POP RIVETS
17	1	32227	32227	32227	INSTRUCTION, CONTROL BOX INSTALLATION
Not Shown	1	32023	31261	30878	OVEN TOP

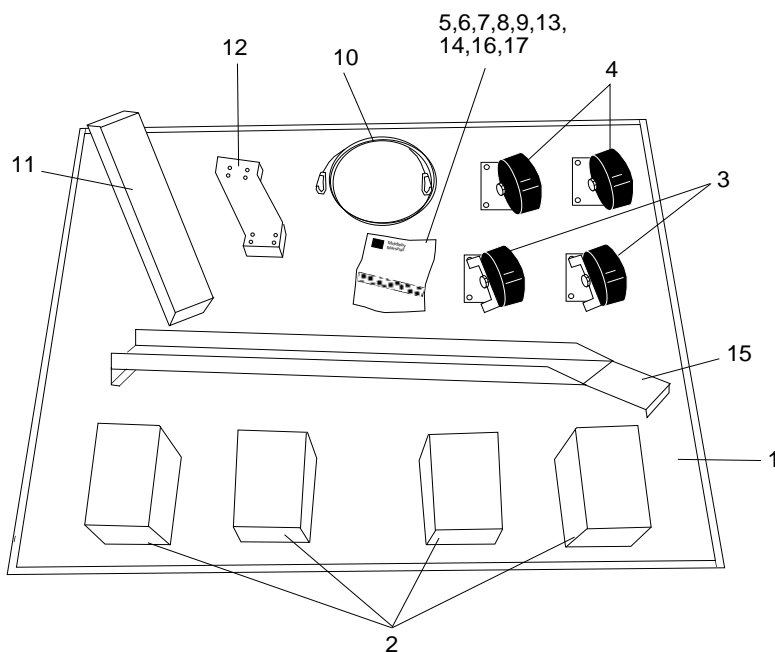

Figure 2-2. Series PS200-R68 Single and Double Oven Option Kits

SECTION 2 INSTALLATION

NOTE: The Model PS200-R68 Series ovens are manufactured with the conveyor drive at either the right or left end of the oven.

- 1 **GAS OVEN:** Gas Inlet
ELECTRIC OVEN: Conduit for Electrical Connection
- 2 **GAS OVEN:** Electrical Junction Box
- 3 **RECOMMENDED MINIMUM CLEARANCES:**
Rear of Oven to Wall - 3" (76mm)
Non-Drive End of Oven to Wall - 0"
Drive End of Oven to Wall - 18" (457mm)
- 4 **OVEN VENT - GAS OVEN ONLY**
2" x 3" (50mm x 75mm)

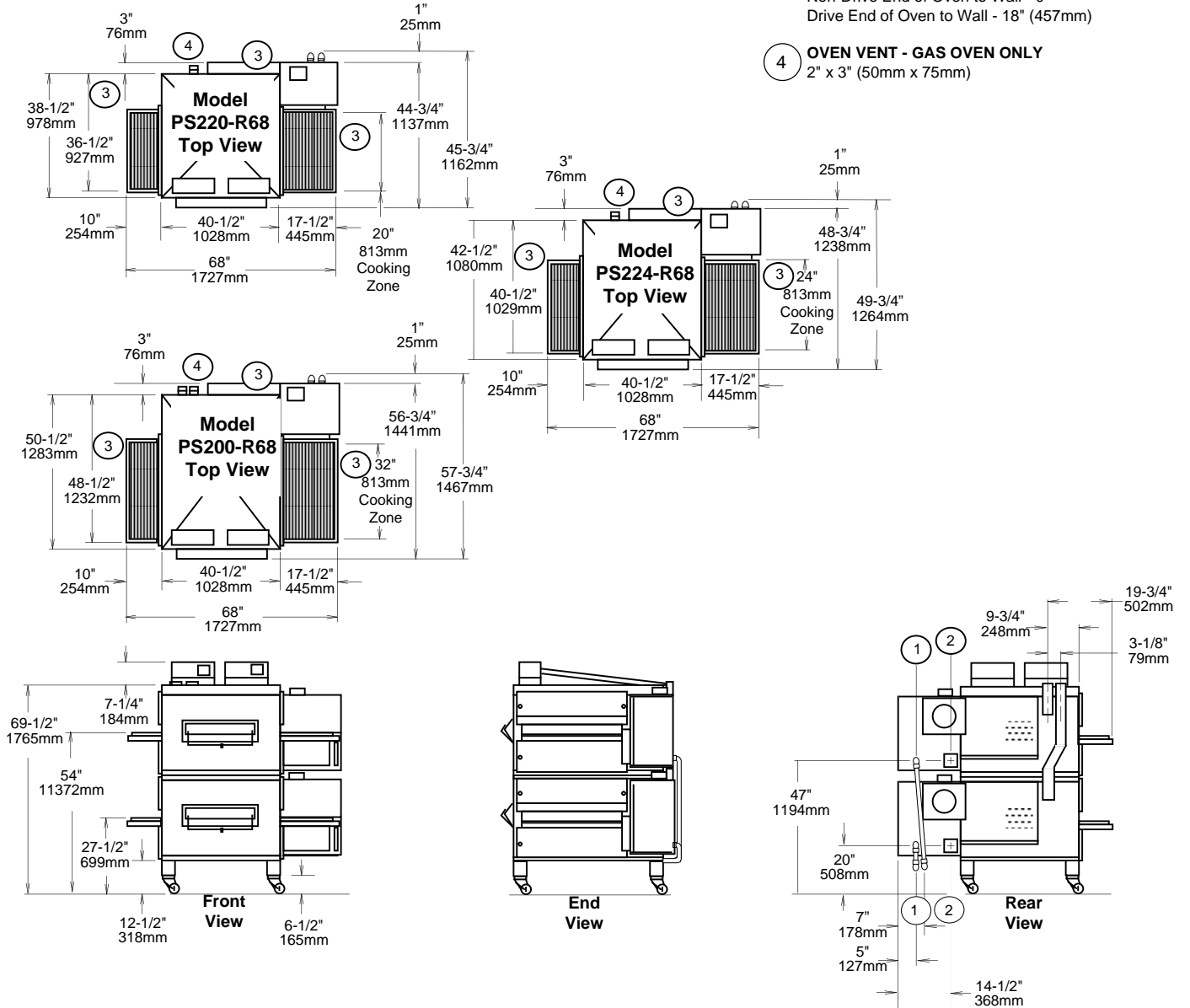

Figure 2-3. Series PS200-R68 Oven Dimensions

SECTION 2 INSTALLATION

II. CONTROL BOX AND CABLE INSTALLATION

CAUTION: When attaching cables turn the circuit breakers off.

A. Install the control boxes, wireway and cables as shown in Figure 2-5.

B. Install the "UPPER" and "LOWER" labels as shown.

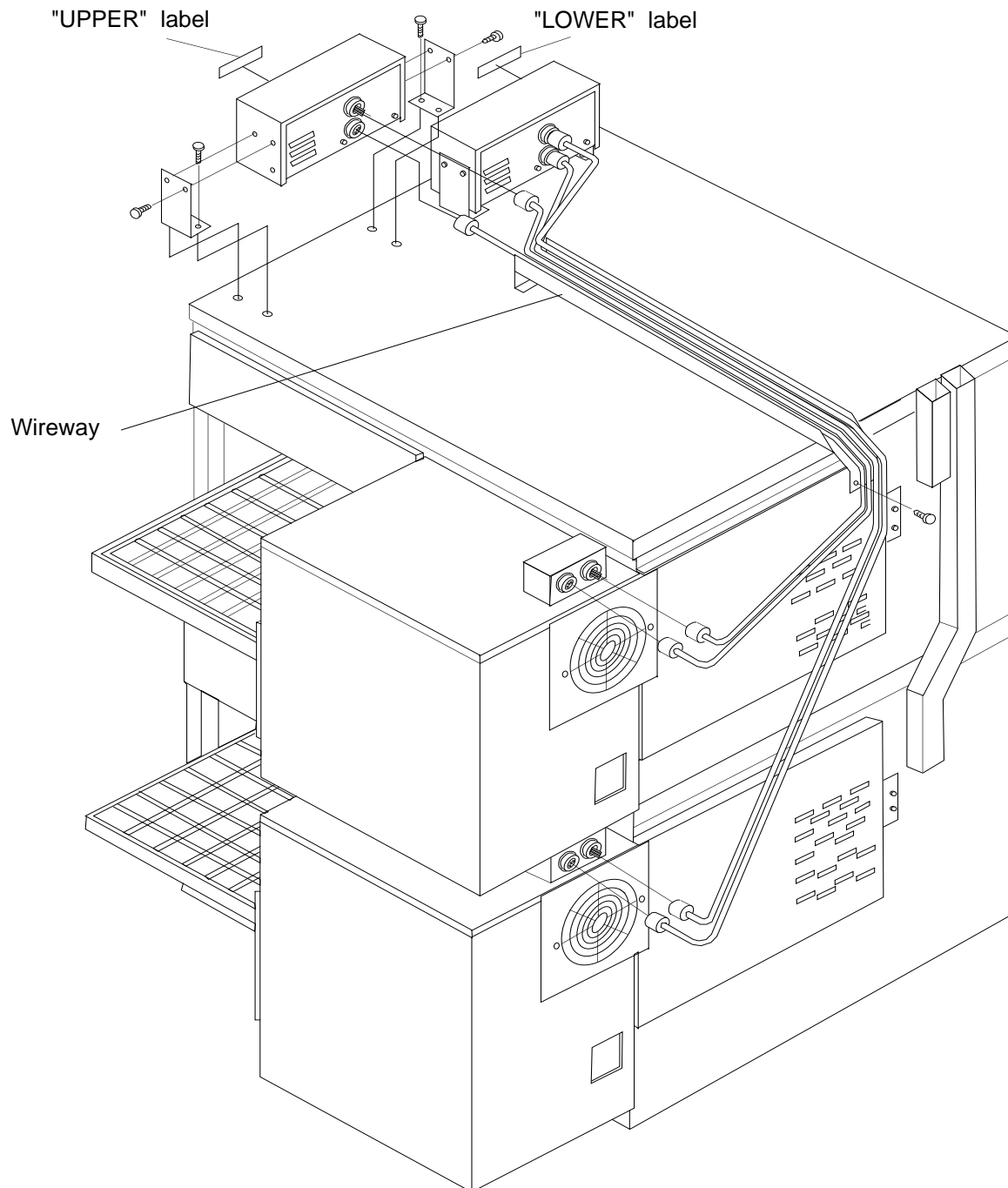

Figure 2-4. Control Box, Wireway and Cable Installation

III. FLUE VENT INSTALLATION

A. Install the flue vent: (Gas oven only)

NOTE: On a single oven the flue is factory mounted.

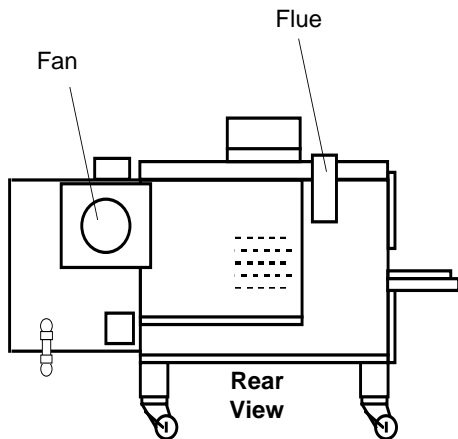

Figure 2-5. Single Oven Flue Installation

B. On a double oven install the flue extension and flue offset by sliding it down over the lower flue. Then attach both flues with the screws provided.

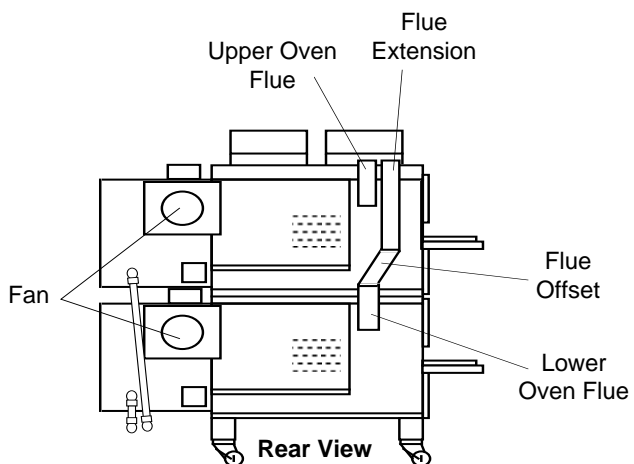

Figure 2-6. Double Oven Flue Installation

IV. RESTRAINT CABLE INSTALLATION

Install the restraint cable assembly on the oven as shown in Figure 2-7.

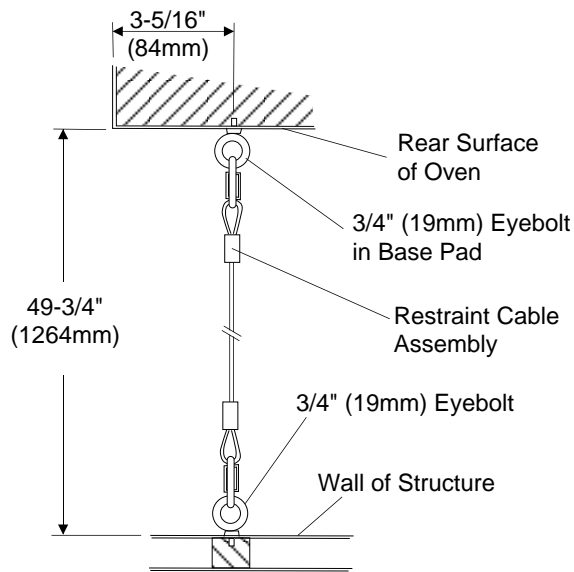
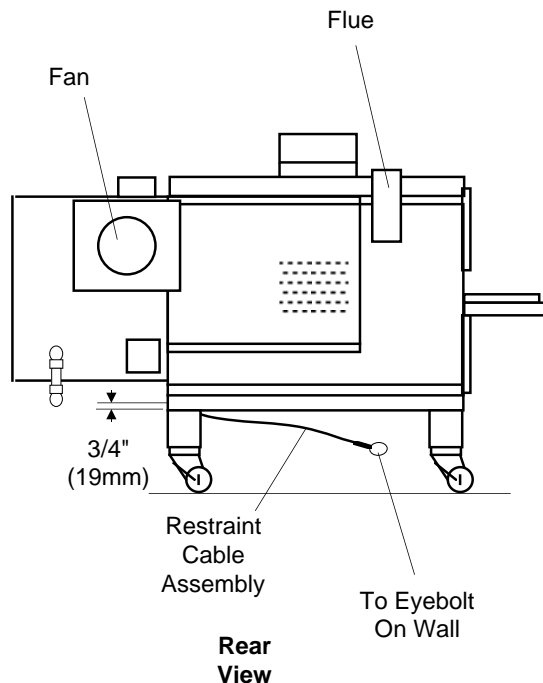

Figure 2-7. Restraint Cable Assembly Installation

GAS OVEN ROUGH-IN

UTILITY ROUGH-IN DIMENSIONS AND POSITIONING FOR PS200-R68 SERIES OVENS

CAUTION

IT IS REQUIRED THAT THE OVEN BE PLACED UNDER A VENTILATION HOOD FOR ADEQUATE AIR SUPPLY AND VENTILATION.

**GAS SUPPLY &
ELECTRICAL SUPPLY
PROVIDED BY CUSTOMER**

**DO NOT USE CONDUIT
FOR GROUND**

CIRCUIT BREAKER

15 Amp circuit breaker **with lockout/tagout electrical shutoff** for each cavity. Wire each cavity separately.

ELECTRICAL SPECIFICATIONS

DOMESTIC: 208-240V main blower motors, 1 Ph, 4.1 Amp draw, 50/60 Hz, 120V control circuit, 3 pole, 4 wire system per cavity (2 hot, 1 neut, 1 grd). Do not use conduit for ground.

or

EXPORT: 200-208V or 220-240V main blower motors, 1 Ph, 4.1 Amp draw, 50/60 Hz, 120V transformer control circuit, 2 pole, 3 wire system per cavity (2 hot, 1 grd). Do not use conduit for ground.

GAS RATING

Model PS200-R68 is 120,000 BTU/Hour (30,240 kcal), 35.1 kW/HR
Models PS224-R68 & 220-R68 are 100,000 BTU/Hour (25,200 kcal), 29.3 kW/HR

MINIMUM GAS METER RATING

450 Cu.Ft./Hour (12.74m³h) for 1 or 2 oven cavities.
Add 180 Cu.Ft./Hour (5.1m³h) for each additional cavity.
Minimum rating may not take other gas appliances into consideration. Gas consumption varies at each site. Total BTU/HR (kcal/hr) must be calculated on high flame off of each appliance to determine if meter needs to be larger.

MINIMUM GAS PIPE SIZE

Natural: 2" (51mm) ID for 1 or 2 oven cavities with runs up to 200 ft.(61m).
or
2-1/2" (64mm) ID for 3 or 4 oven cavities with runs up to 200 ft.(61m)

Must be a dedicated line.
Runs over 200 ft. consult factory

Propane: 1-1/2" (38mm) ID for 1 or 2 oven cavities with runs up to 200 ft.(61m).
or
2" (51mm) ID for 3 or 4 oven cavities with runs up to 200 ft.(61m).

Must be a dedicated line.
Runs over 200 ft. consult factory

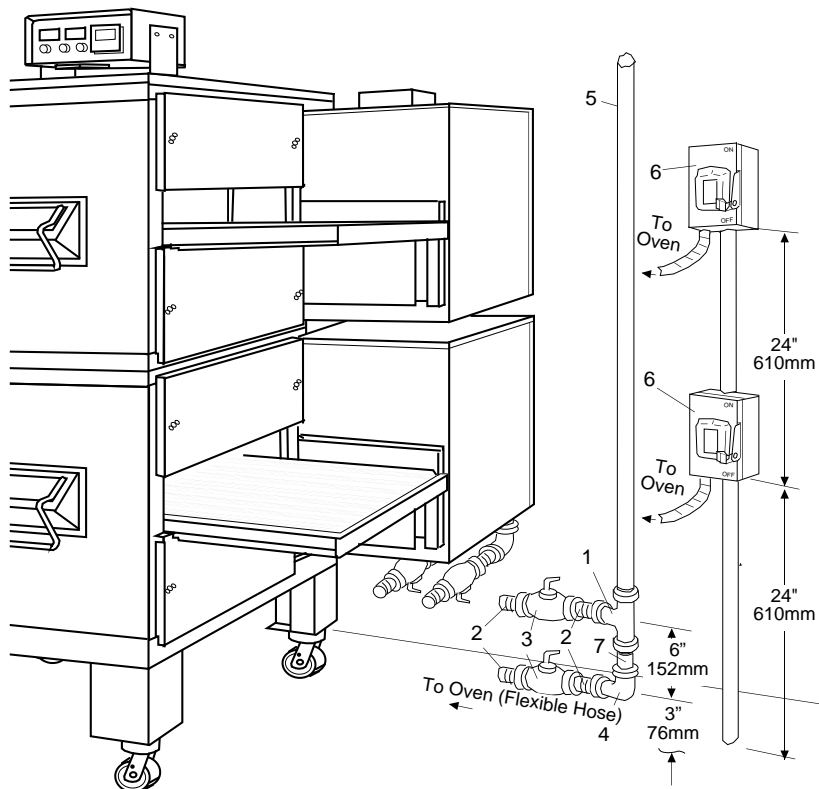

**Figure 2-8
Typical Installation**

GAS SHUTOFF VALVES

3/4" (19mm) ID **full flow** gas shut-off valve.
A separate connection and valve must be provided for each oven.

REQUIRED SUPPLY GAS PRESSURE

Natural: 6" to 14" (152 to 356mm) water column
Propane: 11.5" to 14" (290 to 356mm) water column

SUGGESTED

If space permits service should be located at the drive end of the ovens to allow access to switches and valves.

User Supplied Items:

ITEM	QTY	DESCRIPTION
1	1	2"(51mm) X 2"(51mm) X 3/4"(19mm) TEE
2	3	3/4"(19mm) X 3"(76mm) NIPPLE
3	2	3/4" (19mm) FULL FLOW GAS SHUT-OFF VALVE
4	1	2"(51mm) X 2"(51mm) 90° ELBOW
5	1	2"(51mm) ID GAS SUPPLY PIPE LINE -NATURAL GAS
6	2	15 AMP TOGGLE SWITCH - 2 POLE for GAS

ELECTRIC OVEN ROUGH-IN

UTILITY ROUGH-IN DIMENSIONS AND POSITIONING FOR PS200-R68 SERIES OVENS

<p>CAUTION</p> <p>IT IS REQUIRED THAT THE OVEN BE PLACED UNDER A VENTILATION HOOD FOR ADEQUATE AIR SUPPLY AND VENTILATION.</p>
<p>ELECTRICAL SUPPLY PROVIDED BY CUSTOMER</p>
<p>DO NOT USE CONDUIT FOR GROUND</p>

CIRCUIT BREAKER

Separate circuit breaker **with lockout/tagout electrical shutoff** for each cavity. Wire each cavity separately. 100 Amp circuit breaker for 200-240V, or 50 Amp circuit breaker for 380-480V.

ELECTRICAL SPECIFICATIONS

DOMESTIC: 208-240V main blower motors and elements, 3 Ph, 75 Amp draw, 50/60 Hz, 120V control circuit, 4 pole, 5 wire system per cavity (3 hot, 1 neut, 1 grd).

or

DOMESTIC: 220-240V main blower motors and elements, 3 Ph, 75 Amp draw, 50/60 Hz, 120V control circuit, 3 pole, 4 wire system per cavity (3 hot, 1 grd).

or

EXPORT: 380V or 400-416V main blower motors and elements, 3 Ph, 50 Amp, 50/60 Hz, 120V transformer control circuit, 4 pole, 5 wire system per cavity (3 hot, 1 neut, 1 grd).

ELECTRICAL RATING

26 kW/HR

SUGGESTED

If space permits service should be located at the drive end of the ovens to allow access to switches and valves.

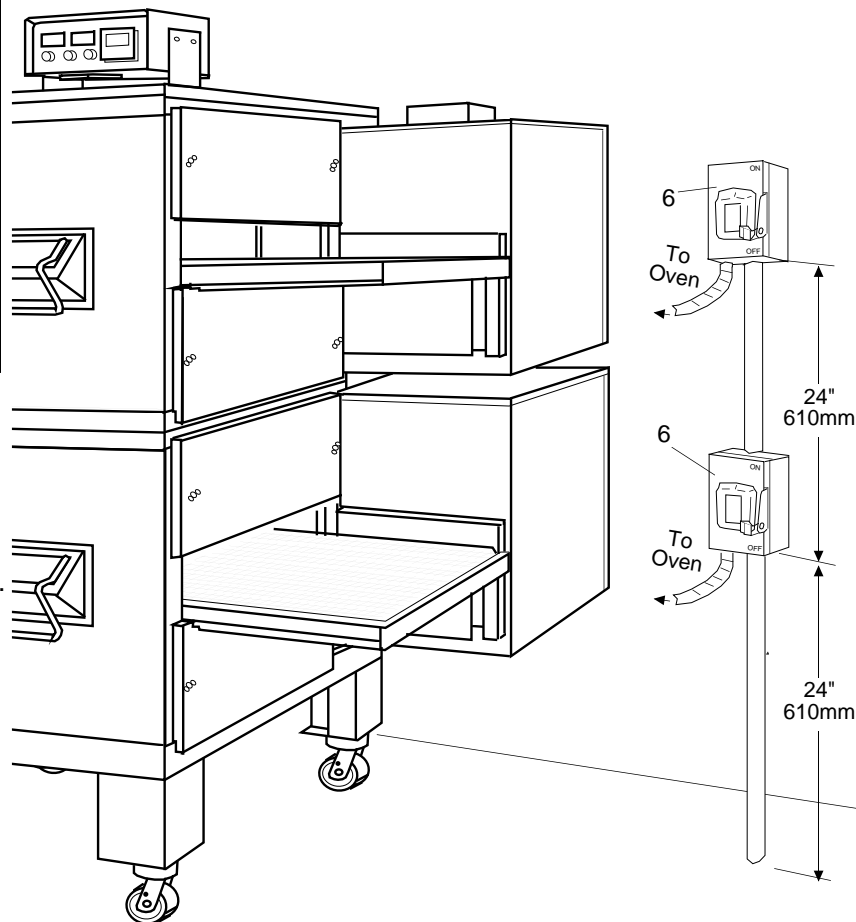

**Figure 2-9
Typical Installation**

SECTION 2 INSTALLATION

V. VENTILATION GUIDELINES

A mechanically driven ventilation system is required for the PS200-R68 Series Middleby Marshall conveyorized gas ovens. The minimum hood canopy dimensions are outlined below.

Local codes and conditions vary greatly from one area to another and must be complied with. These are the "Authority having jurisdiction" as stated by the National Fire Protection Association, Inc. in NFPA 96-latest edition. Following are the suggested requirements for good ventilation. Please remember these are general recommendations or guidelines, you may have a special condition or problem that will require the services of a ventilation engineer or specialist. Proper ventilation is the oven owner's responsibility. Improper ventilation can inhibit oven performance. It is recommended that the ventilation and duct work be checked every three months.

Grease filters in the intake of the hood may be required by local codes.

VENTILATION HOOD

The rate of air flow exhausted through the ventilation system is generally between 1400 and 2500 CFM, but may vary depending on the oven configuration and hood design. To avoid a negative pressure condition in the kitchen area, return air must be brought back to replenish the air that was exhausted. A negative pressure in the kitchen can cause heat related problems to the oven components as if there were no ventilation at all. The best method of supplying return air is through the heating, ventilation and air conditioning system (HVAC). Through the HVAC system, the air can be temperature controlled

for summer and winter. Return air can be brought in directly from outside the building, but detrimental affects can result from either extreme seasonal hot and cold temperature from the outdoors.

NOTE: Return air from fan driven system within the hood must not blow at opening of bake chamber or poor oven baking performance will result.

VENTILATION CAPTURE TEST

It is recommended that a 30 second smoke candle test be performed on your ventilation hood system. Follow the steps below to complete the ventilation smoke test.

All tests are to be done on single ovens or lower units of a double oven. We recommend you wear protective gloves when performing this test. At no time should food be present when the smoke test is being conducted. Also check that no fire suppression system will be activated by the smoke.

1. Turn ventilation system on.
2. Turn oven(s) on and allow to heat up to customers normal operating temperature, or a minimum of 480°F (248°C).
3. Turn conveyor off. Place a 30 second smoke candle in a pie or cake pan which is no higher than 3" (76mm).
4. Open the front oven window. Next, light the smoke candle in the pan and then slide the pan into the center of the bake chamber on the conveyor belt and close the window.
5. The ventilation hood should capture 90% to 100% of the smoke produced by the candle.

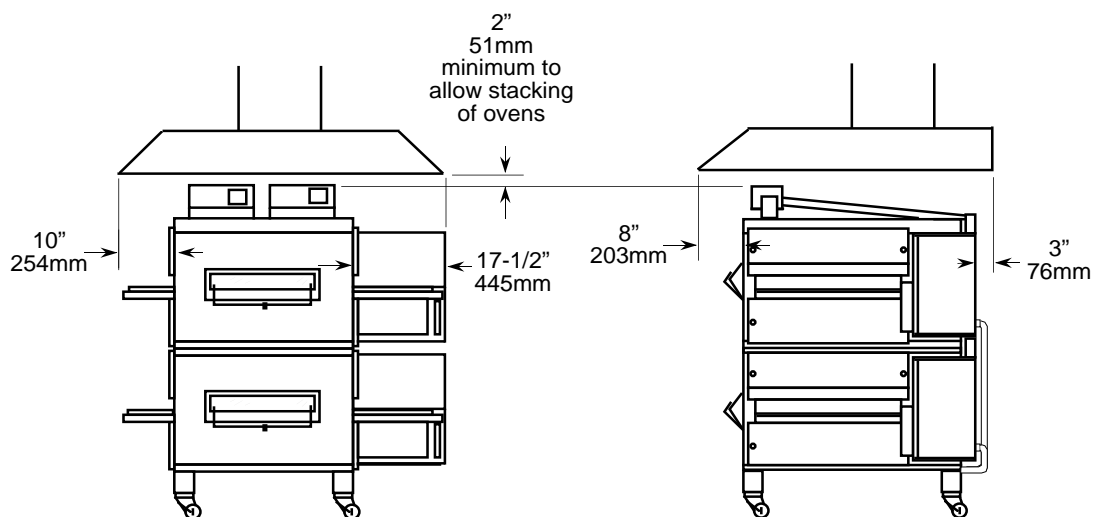

Figure 2-10
Vent Hood

VI. ELECTRIC SUPPLY FOR GAS HEATED OVENS

Electric supply for all gas heated ovens is 208-240 volts AC single phase. Each oven requires a separate 15 amp service. Connection is made as shown in Figures 2-8 & 2-12. A separate ground wire must also be supplied.

CAUTION: Before connecting incoming power to oven, a voltage reading of each leg to neutral must be made. These readings should not normally exceed 120 volts each.

If one of the incoming legs reads over 130 volts, this indicates the supply voltage has a high leg.

Export ovens are supplied with a stepdown transformer for the 110V control circuit.

Call your local electrician or electrical power supply company and have them remove the high leg from the electrical supply line for the oven.

Connecting a high leg to the black lead of the oven will severely damage many of the electrical components in the oven.

CONNECTING A HIGH LEG TO THE BLACK WIRE VOIDS ALL OVEN WARRANTIES.

Connect one 208-240V supply leg to the black wire and the other 208-240V supply leg to the red wire. The supply neutral should connect to the white oven wire and supply ground should connect to the oven ground screw located in the main junction box.

VII. ELECTRICAL CONNECTION INFORMATION FOR ALL OVENS.

Check the oven data plate before making any electrical connections. Connections must agree with data on oven data plate (Refer below to Figure 2-11).

NOTE: In Canada with C22.1, Part 1 and/or local code.

A fused disconnect switch or circuit breaker (not furnished) **MUST** be installed in the electrical supply line FOR EACH OVEN. A lockout/tagout electrical shutoff must be installed for each oven, refer to Figure 2-9. The service connection must meet all national and local electrical code requirements. All connections are made at one common connection at the back of each control box.

NOTE:
When the oven is installed it must be electrically grounded in accordance with local codes, or in the absence of local codes. ANSI/NFPA - Latest edition.

WARNING
OVEN MUST BE KEPT CLEAR OF COMBUSTIBLES AT ALL TIMES.

CAUTION
IT IS REQUIRED THAT THE OVEN BE PLACED UNDER A VENTILATION HOOD FOR ADEQUATE AIR SUPPLY AND VENTILATION

CAUTION:
The power burner will not operate and gas will not flow through the burner without electric power. No attempt should be made to operate the oven during power failure. This oven is to be operated only on the type of gas as shown on the specification data plate.





Middleby Marshall
A MIDDLEBY COMPANY

MODEL NO. SERIAL NO.
 ID NO. TYPE OF GAS
 INPUT BTU PER HOUR MAXIMUM
 MAN. PRESS. IN.W.C. WIRE WITH GROUND
 VAC AMPS AMPS HZ

SUITABLE FOR INSTALLATION ON COMBUSTIBLE FLOORS ADJACENT TO COMBUSTIBLE AND NONCOMBUSTIBLE WALLS WITH THE FOLLOWING MINIMUM CLEARANCES: ZERO INCHES TO LEFT SIDE WALL, EIGHTEEN INCHES TO RIGHT SIDE WALL, SIX INCHES TO BACK WALL.

"INTENDED FOR OTHER THAN HOUSEHOLD USE"
FOR INSTALLATION UNDER VENTILATING HOOD ONLY

ACCEPTED FOR USE
INTERNATIONAL
DEPARTMENT OF BUILDINGS
NEW YORK

MANUFACTURED UNDER U.S. PATENT NUMBERS 3,844,213 AND 4,154,861
 ELGIN, ILLINOIS, 60120, U.S.A. COMMERCIAL OVEN ANS Z 83.12 -

DATA PLATE FOR OVENS WITH THE MACHINERY/DRIVE COMPARTMENT LOCATED AT THE RIGHT END OF OVEN





Middleby Marshall
A MIDDLEBY COMPANY

MODEL NO. SERIAL NO.
 ID NO. TYPE OF GAS
 INPUT BTU PER HOUR MAXIMUM
 MAN. PRESS. IN.W.C. WIRE WITH GROUND
 VAC AMPS AMPS HZ

SUITABLE FOR INSTALLATION ON COMBUSTIBLE FLOORS ADJACENT TO COMBUSTIBLE AND NONCOMBUSTIBLE WALLS WITH THE FOLLOWING MINIMUM CLEARANCES: ZERO INCHES TO RIGHT SIDE WALL, EIGHTEEN INCHES TO LEFT SIDE WALL, SIX INCHES TO BACK WALL.

"INTENDED FOR OTHER THAN HOUSEHOLD USE"
FOR INSTALLATION UNDER VENTILATING HOOD ONLY

ACCEPTED FOR USE
INTERNATIONAL
DEPARTMENT OF BUILDINGS
NEW YORK

MANUFACTURED UNDER U.S. PATENT NUMBERS 3,844,213 AND 4,154,861
 ELGIN, ILLINOIS, 60120, U.S.A. COMMERCIAL OVEN ANS Z 83.12 -

DATA PLATE FOR OVENS WITH THE MACHINERY/DRIVE COMPARTMENT LOCATED AT THE LEFT END OF OVEN

Figure 2-11.
Oven Specification Data Plate Reference

SECTION 2 INSTALLATION

VIII. ELECTRIC SUPPLY FOR ELECTRICALLY HEATED OVENS

Electrically heated ovens are available in 208 or 240 volts, 5 wire, 3 phase only. They are pre-wired at the factory and only one common connection is necessary.

A standard oven is a 5 wire system (3 hot, 1 neut, 1 grd), it will not have a stepdown transformer. The neutral wire is combined with one 208-240 VAC, 3 phase leg to provide a 110V control circuit.

If the oven was special ordered for a 4 wire system, it will use a stepdown transformer for the 110V control circuit.

A 1-1/4" cutout is supplied on the rear of oven control box for the electrical connection. A 1-1/4" strain relief fitting must be used if flexible cable is used to run electrical supply.

Be sure wire size is adequate to handle amperage draw listed on data tag. **Use Copper Wire Only.**

Minimum Supply Conductor ampacity -- 95 Amps Per Unit.

Maximum Supply Circuit protective device -- 100 Amps Per Unit

Normal electrical requirements are as follows:

PS200 Series Single - 208-240V, 3 phase, 5 wire, 27kw, 100 amp service.

PS200 Series Double Oven - 208-240, 3 phase, 5 wire, 54 kw, 2 separate 100 amp services, one for each oven.

FOR OTHER SERVICES CONSULT FACTORY.

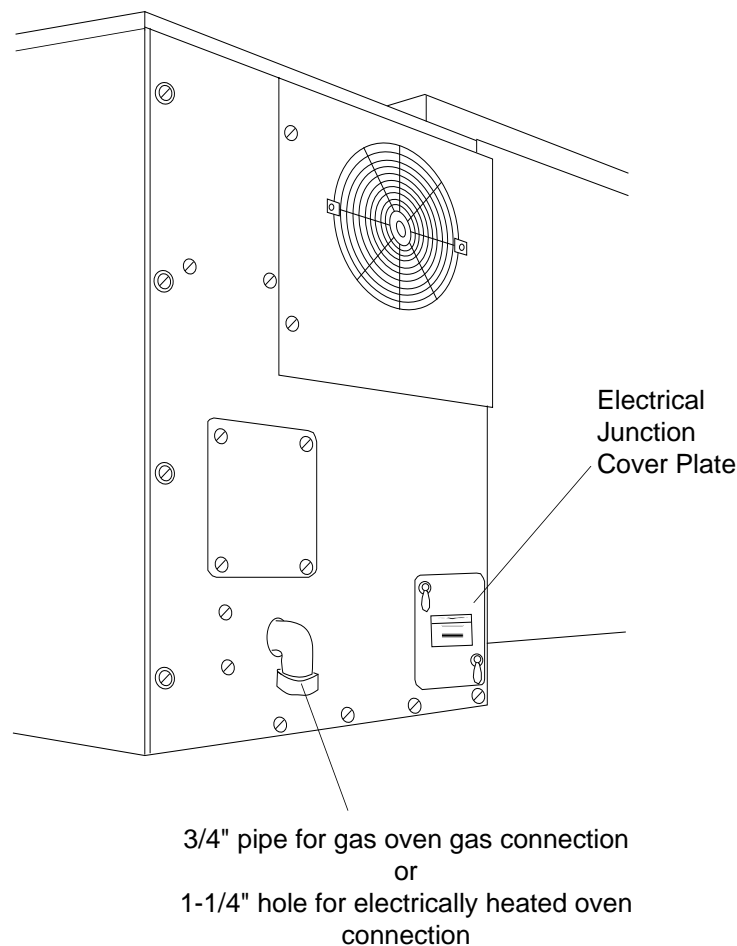

Figure 2-12
Junction Connection Box

CAUTION

**DO NOT CONNECT BLACK
LEAD TO HIGH LEG
BLACK AND WHITE MUST
BE 120 VAC**

High Leg Warning tag located on cover of electrical connection box of gas heated ovens.

IX. GAS SUPPLY FOR GAS HEATED OVENS

Check identification plate located on machinery compartment (see Figure 2-11) to determine type of gas (Propane or Natural) to be used with the oven.

NOTE: If identification plate (Figure 2-11) is missing, natural or propane ovens can usually be determined by checking the manifold pressure rating on the gas combination valve. The rating for natural gas is 3-1/2" w.c. The rating for Propane gas is 10.5" w.c.

Install the manual shutoff valve(s) enclosed with the oven on the 3/4" gas connection pipe extending through the control compartment at rear of oven control box.

If the rear of the oven is installed close to the wall, install the 3/4" elbow on the 3/4" gas connection pipe coming out the rear of the oven and then install the manual shutoff valve(s). This will prevent kinking the connection hose.

The minimum and maximum incoming line flow pressures (when oven(s) and all other gas appliances are on high flame cycle) should be the following:

Natural Gas: 6.0"w.c. Minimum, 14"w.c. Maximum
Propane Gas: 11.5"w.c. Minimum, 14"w.c. Maximum

This incoming pressure reading can be taken by installing a gas pressure gauge in the inlet pressure tap of the main gas valve. See Figure 2-13. Outgoing pressure can be measured at the outlet pressure tap of the main gas valve.

Remember, the longer the pipe runs, the more pressure drops. One 90° elbow equals a 4 foot length of pipe.

NOTE

The installation must conform with local codes or in the absence of local codes, with the National Fuel Gas Code, ANSI Z223, 1-latest edition

In Australia the installation must conform with AGA Code AG601 and with any requirements of the appropriate statutory authority.

CANADIAN:
CAN/CGA-B 149.1 Natural Gas Installation Code
CAN/CGA-B 149.2 Propane Installation Code

On ovens equipped with casters, the installation shall be made with a gas connector that complies with the standard for gas connectors for Moveable Gas Appliances, ANSI Z21.69-1987/CANI 6.10-88(or latest edition), and Addenda, Z21.69a-1989(or latest edition), and a quick disconnect device that complies with the standard for Quick-Disconnect Devices for Use With Gas Fuel, ANSI Z21.41-1989/CANI 6.9M79(or latest edition), and cable restraint assembly (refer to Figure 2-7) must be provided to limit the movement of the oven without depending on the connector and the quick-disconnect device or its associated piping to limit oven movement.

When an oven is required to be removed from its installation for service, shut off the gas valve upstream of the gas connector. Disconnect gas connector, disconnect the restraining device, move oven for servicing.

When service is complete, place oven in original location, connect restraining cable device, connect gas connector, turn gas valve on. Follow standard start up procedure.

Refer below to determine what size gas pipe to run to the oven (NOTE: each oven requires maximum BTU usage of 120,000 BTU per hour for a PS200-R68 or 100,000 BTU per hour for a PS220-R68 and PS224-R68.) The maximum total for a Double Oven would be 240,000 BTU per hour for a PS200-R68 or 200,000 BTU per hour for a PS220-R68 and PS224-R68.

RECOMMENDED SUPPLY PIPE SIZE:

Natural-
2" (51mm) ID for 1 or 2 oven cavities with runs up to 200 ft.(61m).

or
2-1/2" (64mm) ID for 3 or 4 oven cavities with runs up to 200 ft.(61m)

Must be a dedicated line. Runs over 200 ft. consult factory.

Propane-
1-1/2" (38mm) ID for 1 or 2 oven cavities with runs up to 200 ft.(61m).

or
2" (51mm) ID for 3 or 4 oven cavities with runs up to 200 ft.(61m).

Must be a dedicated line. Runs over 200 ft. consult factory.

NOTE: The recommended pipe sizes are larger than usually required to eliminate any operation problems. It is much less expensive to make the initial installment large enough to do the job rather than redoing the job later.

GAS METER SIZE:

Minimum Gas Meter Size:

450 cu.ft./hour (3.2 liters/sec.) for single or double oven.

Add 180 cu.ft./hour (1.3 liters/sec.) for each additional cavity.

CAUTION

DURING PRESSURE TESTING NOTE THE FOLLOWING:

1. The oven and its individual manual shutoff valve (located at the left rear of the oven) must be disconnected from the gas supply piping system during any pressure testing of that system at test pressure in excess of 1/2 psig (3.45 kPA). Turn OFF main gas shutoff valve or main gas supply line.

2. The oven must be isolated from the gas supply piping system by closing its individual manual shutoff valve located at the rear of the oven during any pressure testing of the gas supply piping system at test pressure equal to or less than 1/2 psig (3.45 kPA).

3. If incoming w.c. pressure is over 14" w.c. a separate regulator must be installed before the 3/4" manual gas shutoff valve located at the rear outside of the oven.

WARNING: TO PREVENT DAMAGE TO CONTROL VALVE REGULATOR DURING INITIAL TURN ON OF GAS, IT IS ***VERY IMPORTANT TO OPEN MANUAL SHUTOFF VALVE VERY SLOWLY.***

After the initial gas turn on, the manual shutoff valve must remain open except during pressure testing as outlined in the above steps or when necessary during service maintenance.

It is possible to convert ovens from natural gas to propane and back. Call your local authorized factory service agent to perform the conversion.

NOTE: In Canada to conform with CAN/CGA-B149.2 Propane Installation Code the oven must be ordered Propane, it may not be converted in the field.

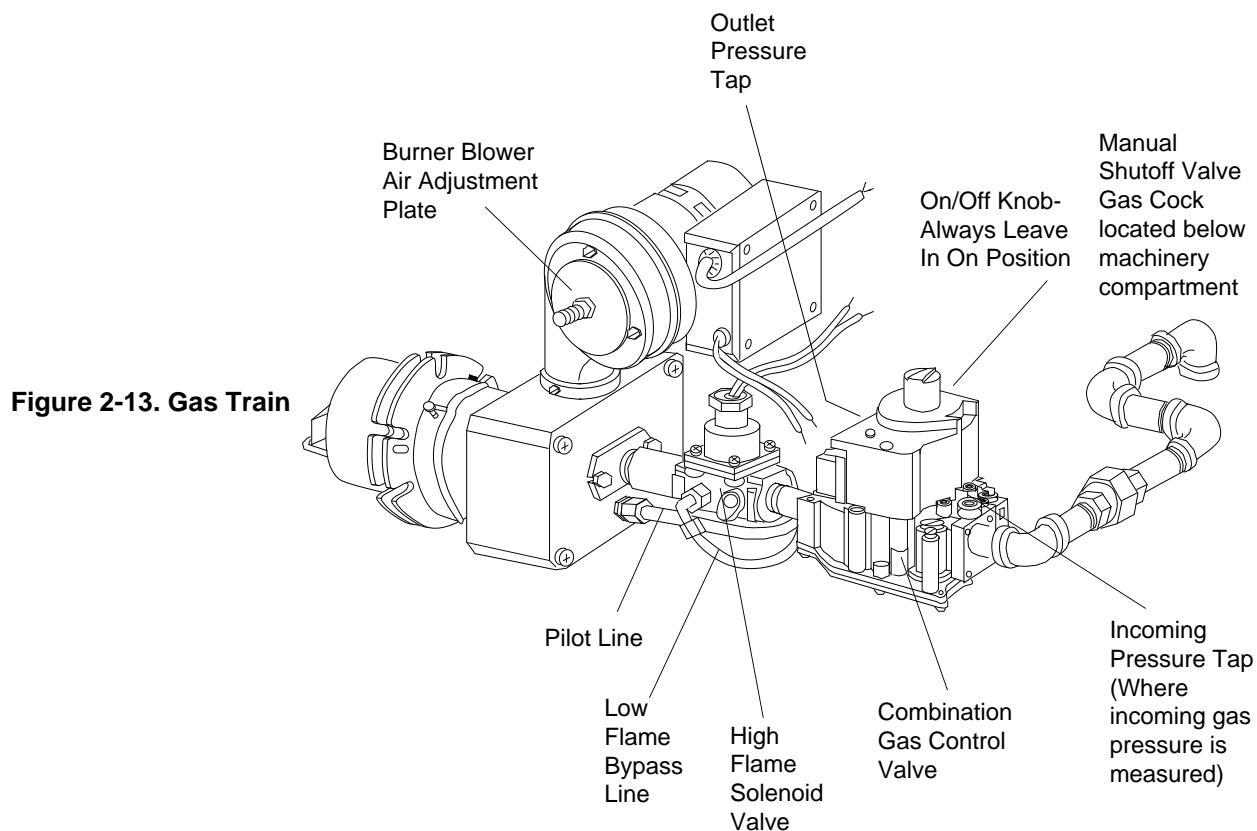

Figure 2-13. Gas Train

X. CONVEYOR BACKSTOP AND END STOP INSTALLATION

Locate the conveyor backstop and end stop in the installation kit. Install the backstop and end stop at the exit end of the oven. Refer to Figure 2-14.

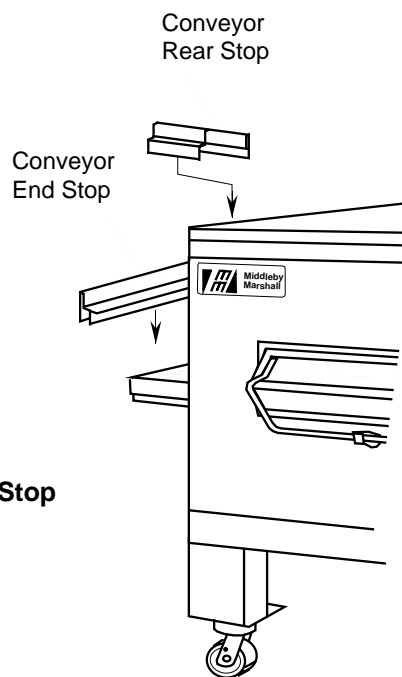

Figure 2-14.
Installing Backstop and End Stop

NOTES:

SECTION 3 OPERATION

I. CONTROLS AND COMPONENTS

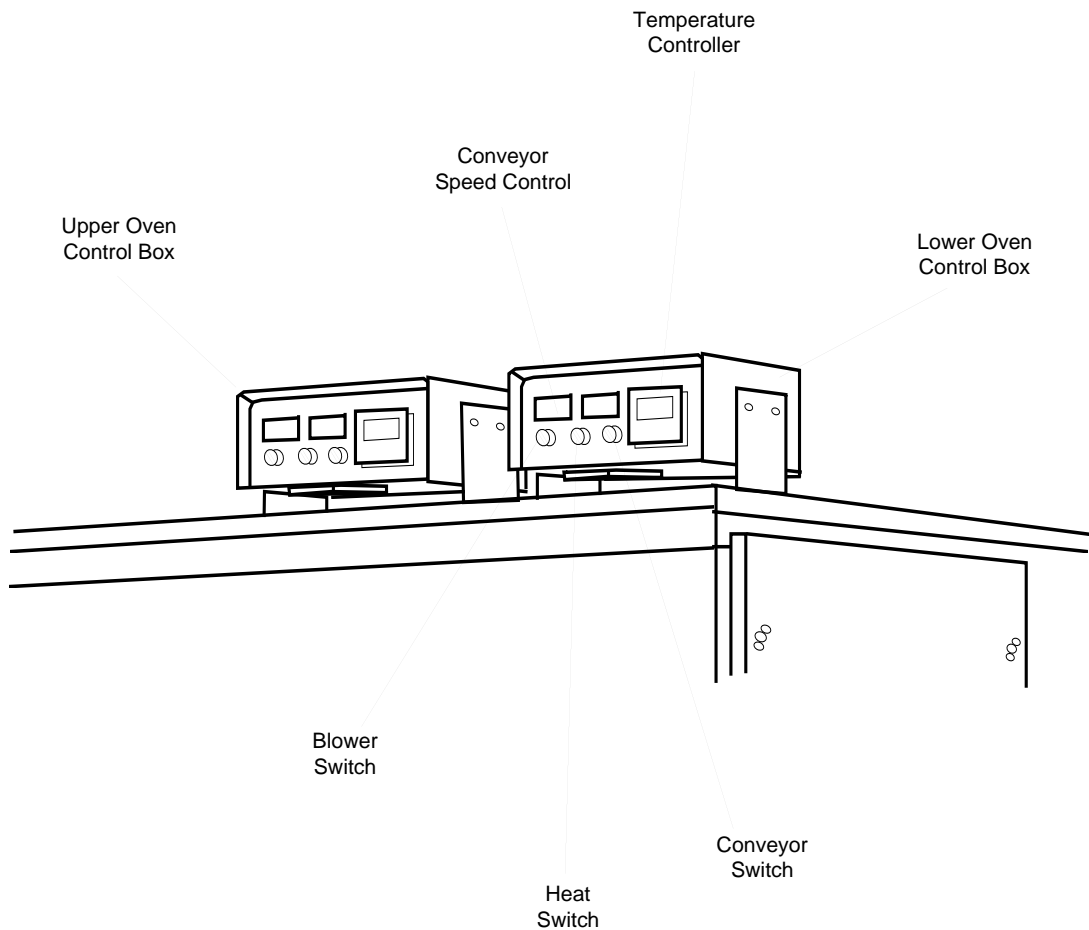

Figure 3-1.
PS200-R68 Series
Control Functions

SECTION 3 OPERATION

II. COMPONENT INFORMATION AND LOCATION

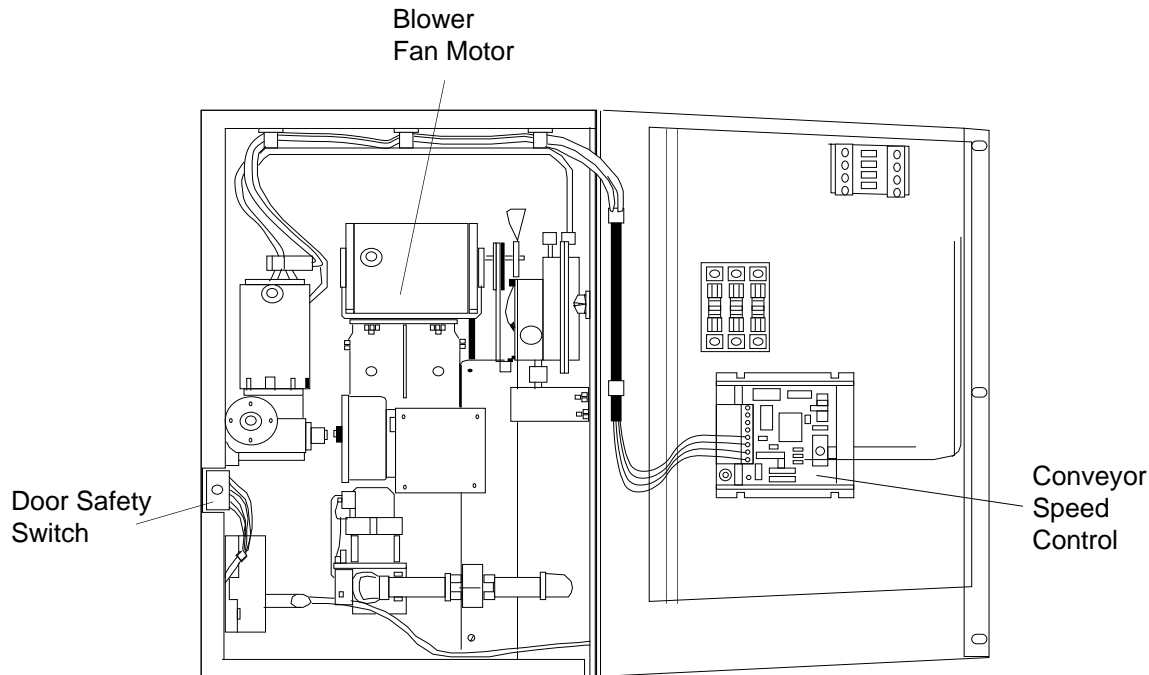



Figure 3-2

A. Door Safety Switch

The Door Safety Switch is located at upper left hand side of control cabinet. Opening the control cabinet door will permit the switch to open, disconnecting power to all electrical controls.

CAUTION: DO NOT TOUCH WIRES GOING TO THIS SWITCH AS CURRENT IS ALWAYS PRESENT.

B. Blower Fan

The blower  switch located on the control box has two positions. The switch must be on (I) for the burner and conveyor to come on and permit the oven to warm up. The fan circulates the air throughout the oven and must stay on during baking and during the cool down cycle above 200° F. (93°C.) to prevent blower bearing damage. To protect the blower motor and bearings a thermostatic override is built into the oven. If the temperature inside the oven is over 180° F. (82° C.) the main blower and conveyor will continue to run even when the blower  switch is turned to the off position.

An air pressure switch monitors the air flow from the main blower, this acts as a safety interlock for the burner. The heat will not come on if the air switch does not sense air flow off the main blower fan.



C. Heat (Gas ovens only)

Turning the heat  switch to on (I) will initially set up the

oven purge circuit after approximately 30 seconds the pilot will light. After the pilot is lit the main control valve will open permitting gas to go to the burner and heat the oven.

This switch is in series with the burner blower motor centrifugal switch, high temperature safety switch and blower fan air pressure switch. All three safety switches must be closed for gas to flow and the burner to light.

D. Temperature Controller

The temperature  controller located on the control box is a solid state on/off type which is used to maintain the desired set temperature. The temperature  controller continuously monitors the oven temperature and turns high flame solenoid valve on in gas heated ovens. The heat is on for the time required to maintain a constant temperature.

The temperature controller contains a Hi-Limit switch which will shut down the oven when the oven reaches 650°F. (343° C.) and a low-limit switch which allows the oven to cool down to 180°F. (82° C.) before shutting off the blowers.

E. Heat (Electrically heated ovens only)

Turning the heat  switch located on the control box to on (I) will energize the electric heating system. This switch is in series with the blower fan motor centrifugal switch and high temperature override switch. Both switches must be closed before the elements may be energized.

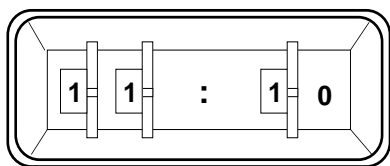

Figure 3-3. Conveyor Speed Digital Control

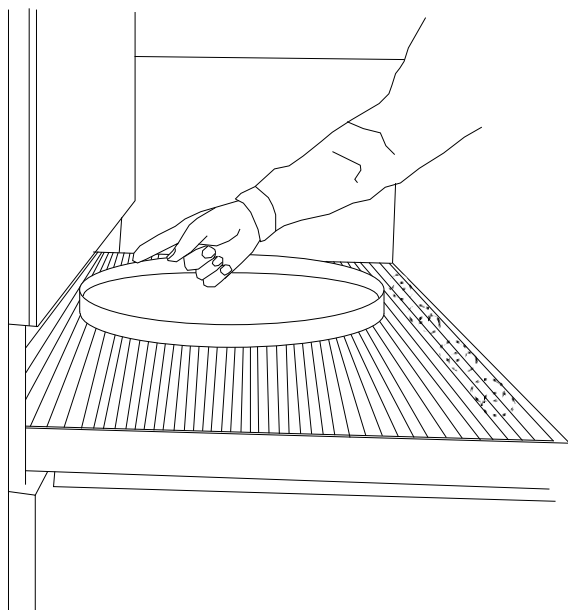

Figure 3-4. Product at entrance end of bake chamber- BEGIN TIMING.

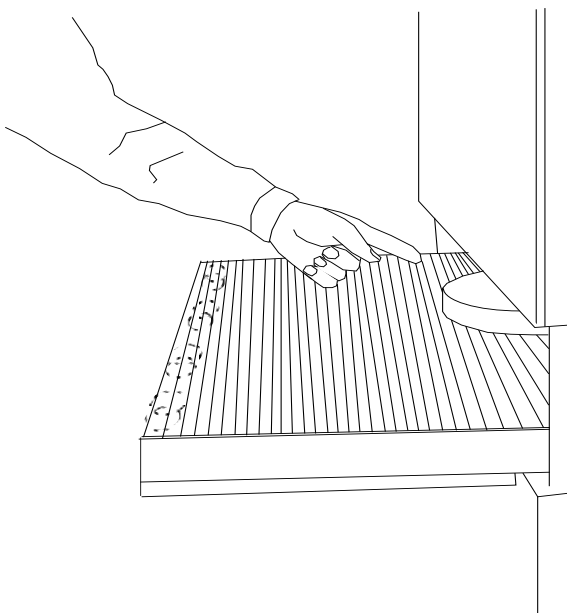



Figure 3-5. Product at exit end of bake chamber-END OF TIMING

F. Conveyor

The conveyor  switch is on the control box. Also on the control box is the digital control for the conveyor speed. The digital control can be adjusted from 2 minutes 40 seconds to 29 minutes 50 seconds bake time  (conveyor speed). Refer to Figure 3-3.

Conveyor speed is measured by the amount of time it takes for an item to go through the bake chamber of the oven.

MEASURING CONVEYOR SPEED. Refer to Figure 3-4 & 3-5.

To check conveyor speed place an item at the product entrance end of oven bake chamber as shown. Time how long it takes for the leading edge of the item to go from the entrance end of the bake chamber to the exit end and this will be your conveyor speed.

NOTE: In Figures 3-4 & 3-5 the oven shown has the conveyor running right to left.

CAUTION

Possibility of injury from rotating parts and electrical shock exist in this oven.

Never disassemble or clean the oven with the blower switch or any other part of the oven turned "on". Turn OFF and lockout or tagout all electrical power to the oven before attempting to clean or service this oven.

SECTION 3 OPERATION

II. OPERATION

A. Start Up Procedures -- Gas Heated Ovens

Initial Start Up

1. Check that manual gas shutoff valve is on. Valve is located below machinery compartment. See Figure 2-12.

Daily Start Up

1. Turn blower  switch to the on (I) position. This starts the main blower fan and the cooling fan. The blower circulates air through the air fingers and must stay on during the cooking or baking process.

2. Check to see if the cooling fans (see Figures 1-4 and 1-6) are operating when the blower switch is turned on (I). The cooling fans cool the electrical components and burner blower motor. The cooling fan, located at the rear of the machinery cabinet blows air into and through the cabinet. Air is exhausted out the back of the oven. A cooling fan is also located in the bottom of the control box to draw air through the rear louvers and out the bottom.

Clean the cooling fan grills and louvers daily.

IMPORTANT NOTE: *The cooling fan will operate when the blower switch is turned on (I). It must operate to keep the machinery cabinet below 140°F. (60° C.).*

WARNING: *IF FAN BLADE IS NOT ROTATING, BROKEN OR IF FAN ASSEMBLY IS MISSING FROM MAIN BLOWER MOTOR SHAFT, DO NOT OPERATE OVEN. REPLACE COOLING FAN BLADE BEFORE OPERATING OVEN. Serious damage could be done to the burner blower motor and/or the solid state electrical components if oven is operated while cooling fan is not running or vent grill is plugged.*

3. Turn the conveyor  switch to the on (I) position. This now starts the conveyor belt moving through the oven. Set conveyor speed digital control for desired bake

time .

4. The temperature  controller should be set at your desired baking temperature. See section on bake times to determine desired temperature.

NOTE: *For complete temperature controller operation instructions refer to Step B.*

5. Turn the heat  switch to the on (I) position. This will complete a circuit which supplies power to the burner. When an oven that has not been in operation for approximately 1/2 hour is turned on it goes through a 15 second purge cycle. The burner blower motor will not operate during the time the main fan is purging the oven. After 15 seconds the burner blower motor starts, which can be detected by feeling a slight vibration when touched. This should permit the burner to light.

When in operation, the burner is either on low or high flame. A flame sensing electrode must be satisfied to keep the pilot and gas valve open. If for some reason the pilot flame is extinguished, the pilot will try to relight for 90 seconds. If the pilot does not relight in 90 seconds the oven will go into automatic safety lockout.

To relight the oven the heat  switch must be turned off for 5 minutes and then repeat the oven start-up procedure.

6. Close front window.

7. Oven will reach a baking temperature of 500° F (260° C) in approximately 10 minutes. Allow the oven to cycle for 30 minutes after it has reached desired bake temperature and the oven is now ready for baking.

Power Failure

In case of power failure, turn off all switches, open oven window and remove product. After power has been reestablished follow normal start-up procedure.

CAUTION

The burner will not operate and gas will not flow through the burner without electric power. No attempt should be made to operate the oven during power failure.

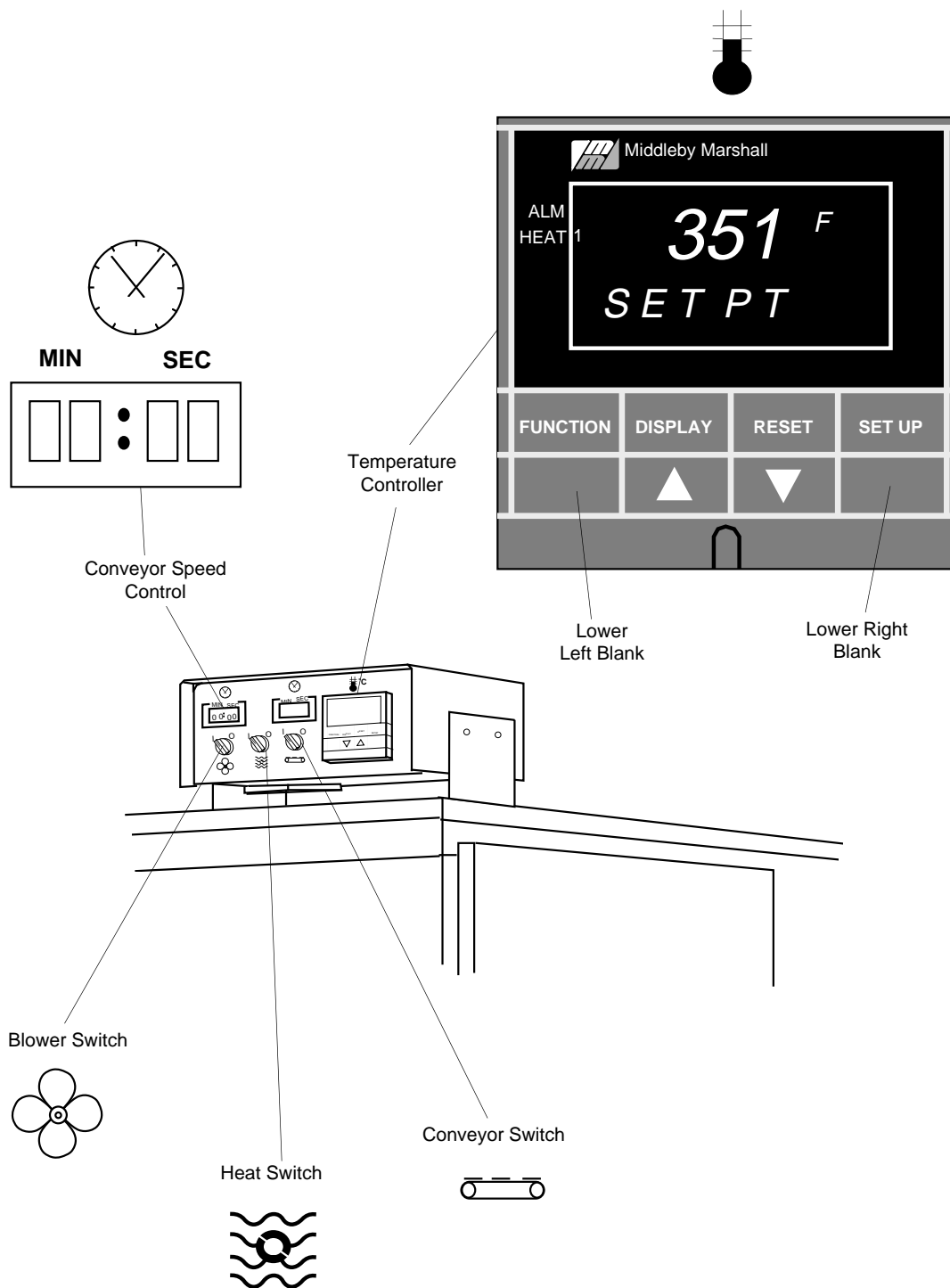

Figure 3-6. Control Panel

SECTION 3 OPERATION

B. Temperature Controller Operation Instructions

1. **UNLOCKING SET POINT.** The temperature controller set point must be 450°F (232.2°C) for the upper oven and 350°F (176.7°C) for the lower oven. To raise or lower the set point on a Red Lobster oven the set point must first be unlocked by pressing the Lower Left Blank and the Lower Right Blank keys simultaneously. The set point will remain unlocked for 60 seconds or until the DISPLAY key is pressed.

- a. Raising the temperature set point. Refer to Figure 3-7.

AA. Slow Method: 1 Degree increments.

Press the UP Arrow Button (▲). The temperature set point will increase one degree. If this button is kept depressed, the temperature set point will continue to increase in one degree increments.

BB. Fast Method: 10 Degree increments.

Press and hold the UP Arrow Button (▲). The temperature set point will begin to increase one degree at a time. With your other hand, press the DOWN Arrow Button (▼) and release. The temperature set point will begin increasing in 10 degree increments.

CC. Fast Method: 100 Degree increments.

Press and Hold the UP Arrow Button (▲). The temperature set point will begin to increase by one degree at a time. With your other hand, press the DOWN Arrow Button (▼) once and release. The temperature set point will begin increasing in 10 degree increments. Press the DOWN Arrow Button (▼) again and release. The temperature set point will begin increasing in 100 degree increments. See Figure 3-7.



Figure 3-7

- b. Lowering the temperature set point.

AA. Follow the previous steps AA through CC for raising the temperature set point but use the opposite UP/DOWN Arrow Buttons.

2. Displaying the actual oven temperature. Refer to Figure 3-8.

a. To check the oven temperature press the DISPLAY Button once and the actual oven temperature and the word "TEMP" will be displayed. See Figure 3-8.

b. Press the DISPLAY Button again and the display will return to the temperature set point. If the DISP key is not pressed, then the display will automatically return to the temperature set point after 60 seconds.



Figure 3-8

3. Display Messages

- a. ALM - The ALM window will display either a “1” or “2” or will be blank.

AA. Refer to Figure 3-9. The “1” signals that the oven temperature is above 650°F (343°C) and therefore the high limit feature has been activated. The burner will then shut off and the oven will not function until the temperature cools down below 650°F (343°C).

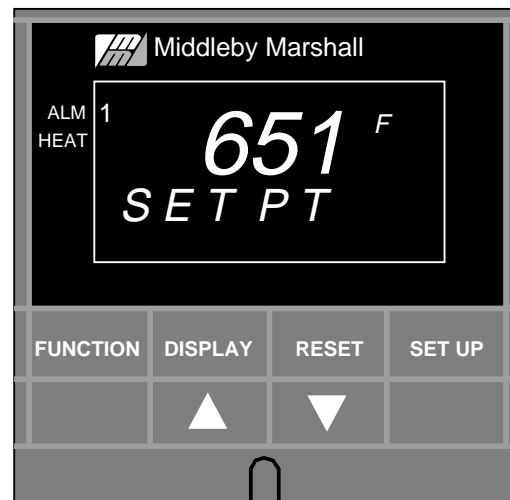

Figure 3-9

BB. Refer to Figure 3-10. The “2” signals that the oven temperature is below 180°F (82°C). The “2” will appear only when the oven is initially heating up and has not yet reached 180°F (82°C) or the heat switch is turned off and the oven has cooled down below 180°F (82°C).

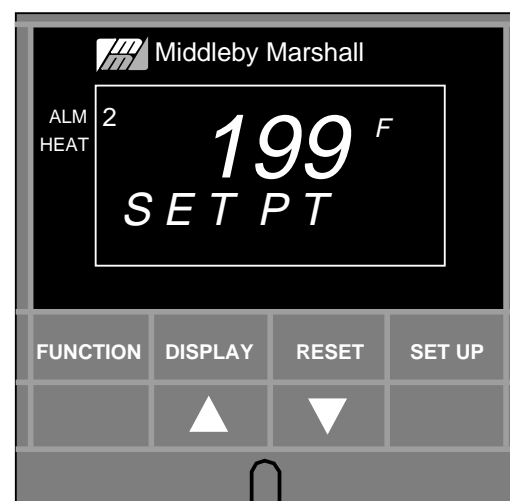

Figure 3-10

CC. The ALM window is blank during normal operation when the oven temperature is 180°F to 650°F (82°C to 343°C).

- b. HEAT - The HEAT window will display either a “1” or will be blank. Refer to Figure 3-11.

AA. The “1” signals that the temperature controller is calling for heat and the burner is turned full on.

BB. When the HEAT window is blank the temperature set point has been reached and the burner is turned down to low flame.

CC. The “1” will continue to blink on and off every few seconds during normal operation. This indicates that the temperature controller is maintaining the correct temperature.

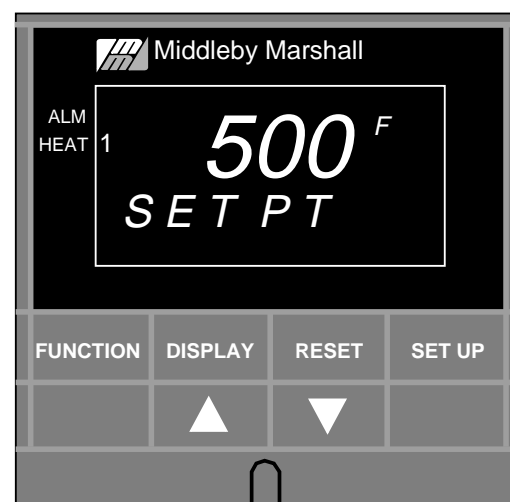

Figure 3-11

SECTION 3 OPERATION

c. FAILSF (Failsafe)

AA. Refer to Figure 3-12. If the oven does not reach 200°F (93°C) in 15 minutes the temperature controller will shut off the high flame valve and begin flashing “FAILSF” and “SET PT” alternately. You will also note that the “2” in the ALM window stays on but the “1” in the HEAT window turns off. This condition signals a problem in oven heating or heat sensing.

BB. To reset the temperature controller, turn off the oven blower switch. Wait 10 seconds and turn the oven blower switch back on. The “2” in the ALM window, the “1” in the HEAT window, the current temperature set point, and the words “SET PT” will be displayed again. The temperature controller will now cycle through its normal procedures.

d. F/C - The F/C window will display either an “F” or a “C”.

AA. The “F” indicates that the temperature displayed is in degrees Fahrenheit.

BB. The “C” indicates that the temperature displayed is in degrees Celsius.



Figure 3-12

C. Start Up Procedures -- Electric Ovens



1. Turn blower  switch to the "ON" position. This starts the main blower fan and cooling fan. The blower circulates air through the air fingers and must stay on during the cooking or baking process. The cooling fan cools the electrical components and blower fan motor of the oven.

2. Check to see if the cooling fans (see Figures 1-4 and 1-6) are operating when the blower switch is turned "ON". The cooling fans cool the electrical components and burner blower motor. The cooling fan, located at the rear of the machinery cabinet blows air into and through the cabinet. Air is exhausted out the back of the oven. A cooling fan is also located in the bottom of the control box to draw air through the rear louvers and out the bottom.

Clean the cooling fan grills and louvers daily.

IMPORTANT NOTE: The cooling fan will operate when the blower switch is turned "ON". It must operate to keep the machinery cabinet below 140°F. (60° C.).

WARNING: IF FAN BLADE IS NOT ROTATING, BROKEN OR IF FAN ASSEMBLY IS MISSING FROM MAIN BLOWER MOTOR SHAFT, DO NOT OPERATE OVEN. REPLACE COOLING FAN BLADE BEFORE OPERATING OVEN. Serious damage could be done to the burner blower motor and/or the solid state electrical components if oven is operated while cooling fan is not running or vent grill is plugged.

3. Turn conveyor  switch to the "ON" position. This now starts the conveyor belt moving through the oven. Set conveyor speed digital control for desired bake time .

4. Set desired temperature on temperature  controller. Refer to previous Section B for complete temperature controller operation instructions. See section on bake times to determine desired temperature.

5. Turn the heat  switch to the "ON" position. This will complete a circuit which supplies power to the heater.

6. Close front window.

7. When oven reaches desired temperature, wait at least 30 minutes before baking.

Power Failure



In case of power failure, turn off all switches, open oven window and remove product. After power has been reestablished follow normal start-up procedure.

D. Shut Down (Gas or Electric Ovens)

1. Turn "OFF" heat  switch and blower  switch.

CAUTION: Blower fan and conveyor will remain on.

2. Open front window.

3. **Do not turn off conveyor  switch.** The conveyor and blower fan will automatically shut off when temperature goes below 180°F (82°C) The conveyor  switch is used only for emergency shut down of conveyor.

NOTE: For oven servicing and complete shut down, turn OFF main gas shutoff valve located at rear of oven and main electric power supply.

E. Conveyor Speed: Bake Time and Time of Delivery

BAKE TIME (CONVEYOR SPEED) - As stated in the previous paragraphs, bake time (conveyor speed) is defined as the amount of time elapsed between the time the Leading edge of a product enters the oven and the leading edge exits the oven. See Figure 3-13.

Bake Time (Conveyor Speed) is controlled by adjusting the digital speed controller. The setting on the digital speed control dial indicates the actual bake time (conveyor speed).

Bake Time will be the same for any size product

TIME OF DELIVERY- Time Of Delivery is the amount of elapsed time between the period when the Leading edge of a product enters the oven and the Trailing edge of the product is fully discharged and is ready to be delivered to the customer. See Figure 3-14. Time of delivery changes as the product size changes.

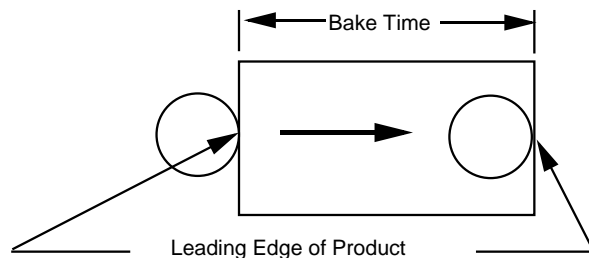

Figure 3-13. Bake time

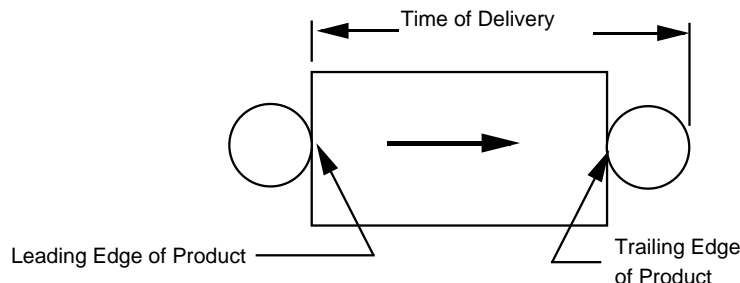

Figure 3-14. Time of Delivery

NOTES:

SECTION 4 MAINTENANCE

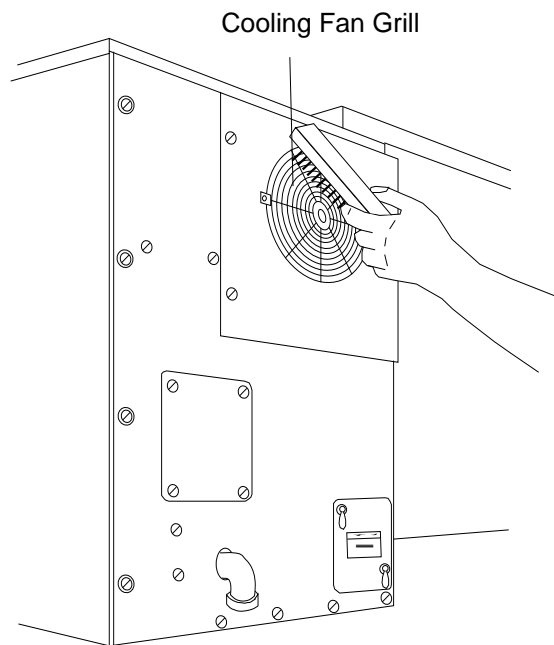

Figure 4-1. Oven Cooling Fan

CAUTION

Possibility of injury from rotating parts and electrical shock exist in this oven.

Turn off and lockout or tagout electrical supply to oven(s) before attempting to disassemble, clean or service oven(s).

Never disassemble or clean the oven interior with the fan switch or any other part of the oven turned "on".

NOTICE

If the oven is to be removed from its installed location for servicing, the following procedure is to be implemented.

1. Shut off main manual gas valve.
2. Disconnect gas connector from oven.
3. Unlock caster brakes and disconnect restraint cable.
4. Move oven to desired location for servicing.
5. When servicing is complete, move oven to original location.
6. Reconnect restraint cable and lock casters w/brakes.
7. Connect gas connector to oven.
8. Turn on manual gas valve.
9. Follow normal lighting instructions.

I. MAINTENANCE - DAILY

A. Exterior

The exterior of the conveyor oven must be cleaned daily. While the oven is still hot dampen a towel or grill pad with plain water or detergent and water and wipe down entire exterior of oven including the back and fan covers. Grease can build up on the top of the oven openings and the area above the windows. If this buildup does not steam off with a damp towel dip the towel in filter powder and rub lightly. Clean exterior any time at the end of each night, even before the oven has been turned off.

B. Cooling Fan

1. THE COOLING FAN GRILL AT THE REAR OF EACH OVEN CONTROL COMPARTMENT MUST BE CLEANED DAILY. ALSO CLEAN THE FAN LOCATED IN THE BOTTOM OF THE CONTROL BOX AND THE LOUVERS IN THE REAR OF THE CONTROL BOX.

2. Check air intake of the cooling fan daily. The best time to check is right after starting the oven.

IMPORTANT NOTE:

The cooling fan will operate when the blower switch is turned "on". It must operate to keep the electrical control cabinet below 140°F. (60°C.).

WARNING

IF FAN BLADE IS NOT ROTATING, BROKEN OR FAN ASSEMBLY IS MISSING FROM MAIN BLOWER MOTOR SHAFT, DO NOT OPERATE OVEN. REPLACE COOLING FAN BLADE BEFORE OPERATING OVEN. Serious damage could be done to the burner blower motor and/or the solid state electrical components if oven is operated while cooling fan is not running.

SECTION 4 MAINTENANCE

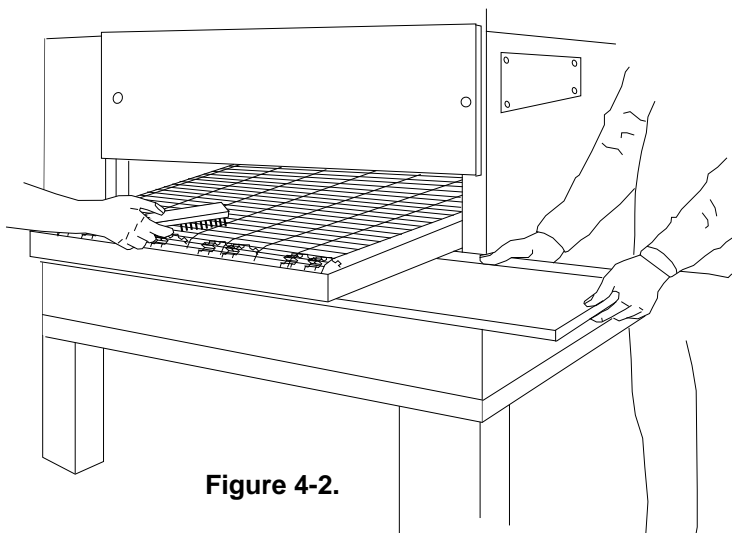

Figure 4-2.

C. Crumb Pans

Remove the crumb pan(s) at both ends of the oven. Crumb pans are removed by sliding out as shown in Figure 4-2. Wash the crumb pans in the pot sink.

CAUTION

Possibility of injury from rotating parts and electrical shock exist in this oven.

Turn off and lockout or tagout electrical supply to oven(s) before attempting to disassemble, clean or service oven(s).

Never disassemble or clean the oven with the fan switch or any other part of the oven turned "on".

II.MAINTENANCE WEEKLY - Oven Disassembly and Cleaning

Use the following instructions to clean the oven interior once a week. To clean the interior 2 people are required to

disassemble the oven. Disassemble the oven the night before and soak the removed parts overnight. Then clean the oven in the early morning before production and line setup. Approximately 2 hours is required.

When cleaning your Series PS200-R68 oven note the following:

PRECAUTIONS-

1. Do not use excessive water or saturation of oven insulation will occur.
2. Do not get water in the fan area located in the bake chamber.

A. Removing conveyor from oven for cleaning

1. Remove crumb pans, conveyor end stops and conveyor rear stops shown in Figure 4-2.

2. Remove upper end plugs from each end of oven. The two wing screws in each end plug are loosened and then the end plugs are removed and set aside. The wing screws should be held in the end plugs by locking washers. If your wing screws drop out of the end plugs order new screws from your local service agency.

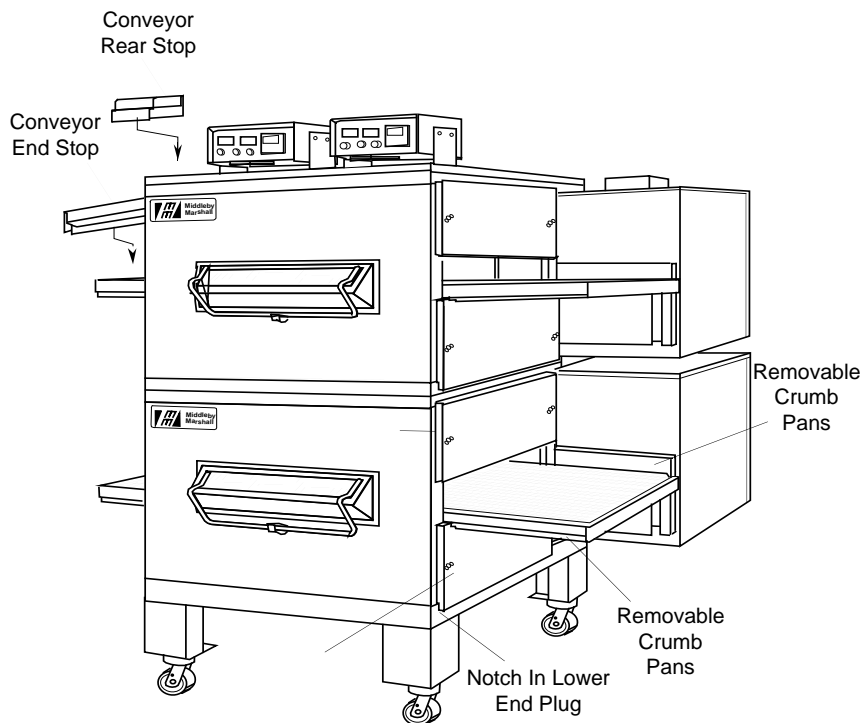
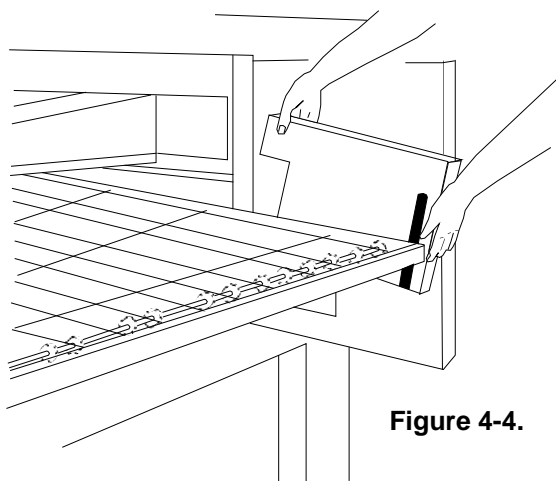
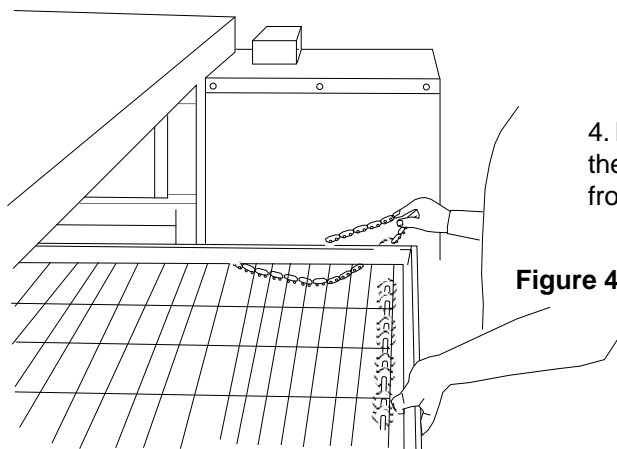

Figure 4-3.



3. Remove conveyor drive chain cover as shown.

Figure 4-4.



4. Remove tension from drive chain by lifting and pushing the conveyor slightly into the oven. Remove drive chain from conveyor drive sprocket as shown.

Figure 4-5.

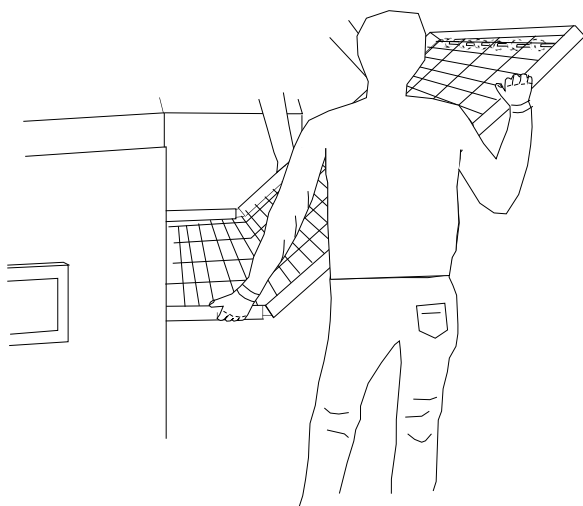

5. While one person pulls the conveyor out from the drive end of the oven the second person should lift the far end (opposite end) of conveyor until crumb tray slide is clear. Then both people can begin sliding conveyor out from the drive end of the oven, as shown, folding as they go. Move slowly and use caution as the conveyor chain and the drive sprocket can be easily damaged.

Figure 4-6.

6. Remove the lower end plug from each end of the oven. Refer to Figure 4-3.

SECTION 4 MAINTENANCE

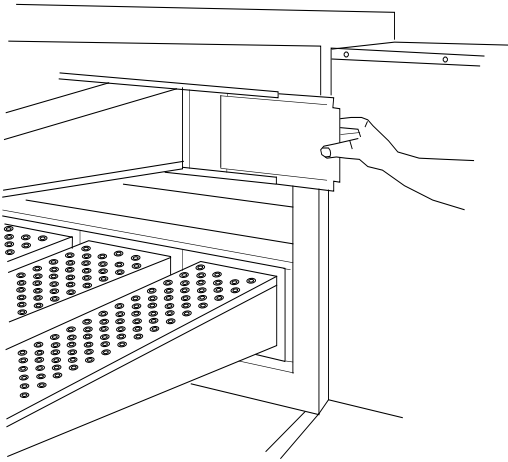

Figure 4-7.

B. Oven interior disassembly.

1. Slide blank plates straight out. There is a blank plate located at each end of the row of top fingers.

2. Remove air fingers. There are four bottom air fingers with 6 rows of holes and 2 top air fingers with 3 rows of holes.

You can remove top and bottom fingers and blank plates from each or either end.

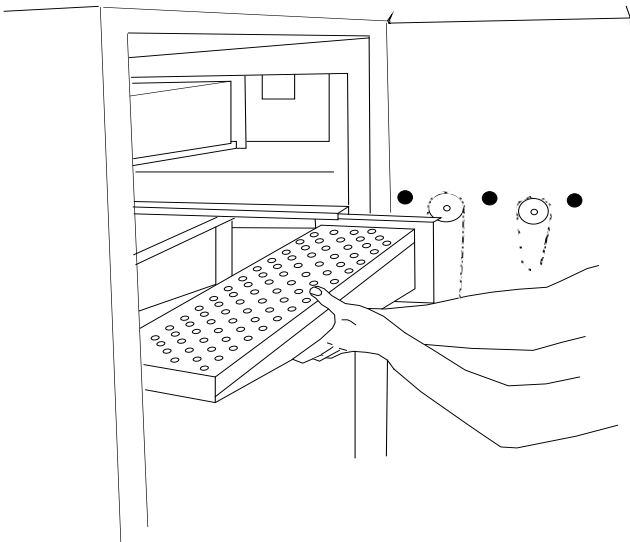

Figure 4-8.

3. Remove the air fingers by pulling the fingers at the back side and pulling straight out.

The finger assemblies should not be disassembled at this time.

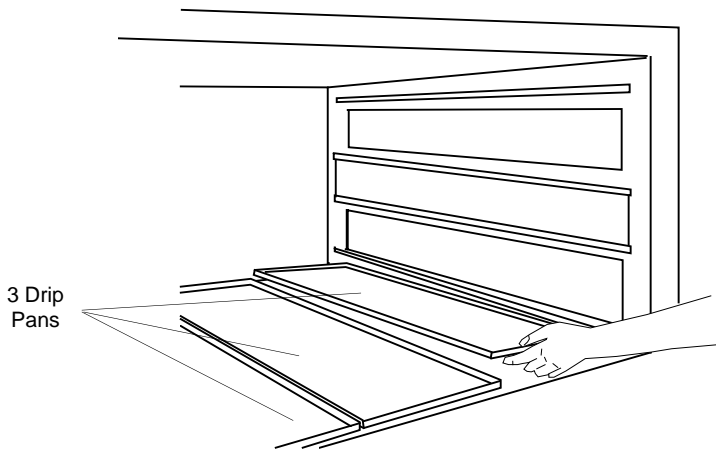

Figure 4-9.

4. Remove the 3 drip pans from the bottom of the oven. Refer to Figure 4-9

C. Window disassembly for cleaning.

1. Remove the window by opening it and unscrewing the window knobs from each end. Place the window knobs on top of the oven in a cup so they can be easily found the next day.

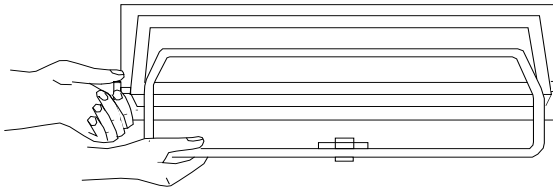

Figure 4-10.

2. Push the window all the way inside the oven, making sure it is clear of the frame. Now, turn the window sideways while inside the oven and then remove it. This will avoid window breakage.

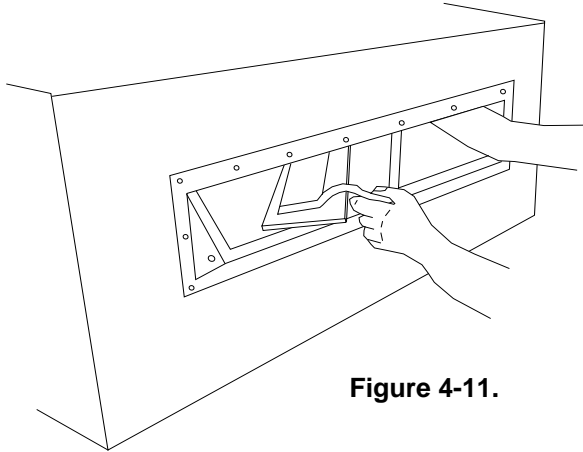

Figure 4-11.

D. Loading the soak bin.

1. Move the soak bin to the dish rack. Close the soak bin drain and add 2 gallons of degreaser and then begin filling with hot water.

2. First load the parts from one oven into one end of the soak bin as follows.

a. Fold the conveyor and load it into the end of the soak bin as shown in Figure 4-12.

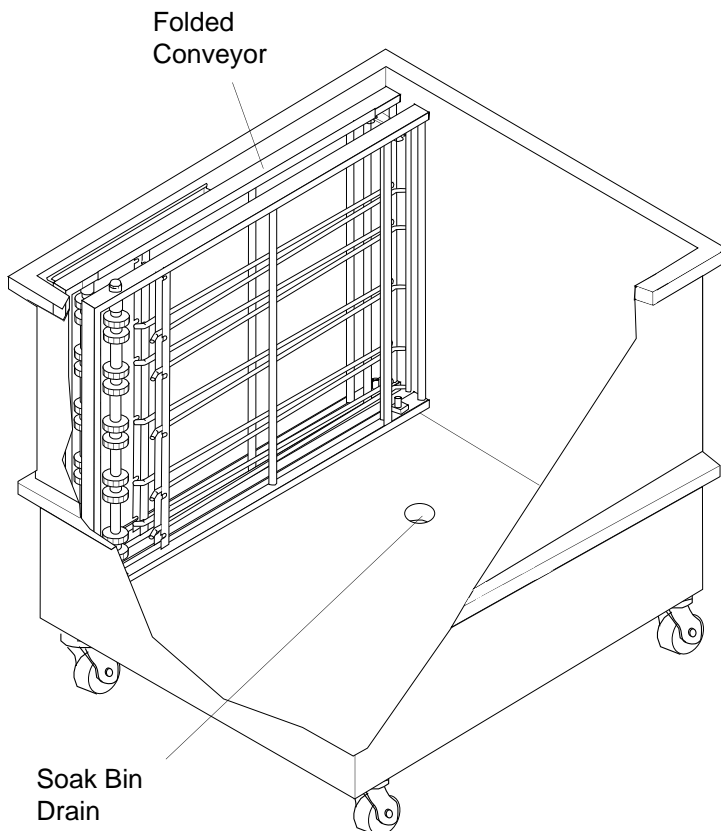

Figure 4-12.

**SECTION 4
MAINTENANCE**

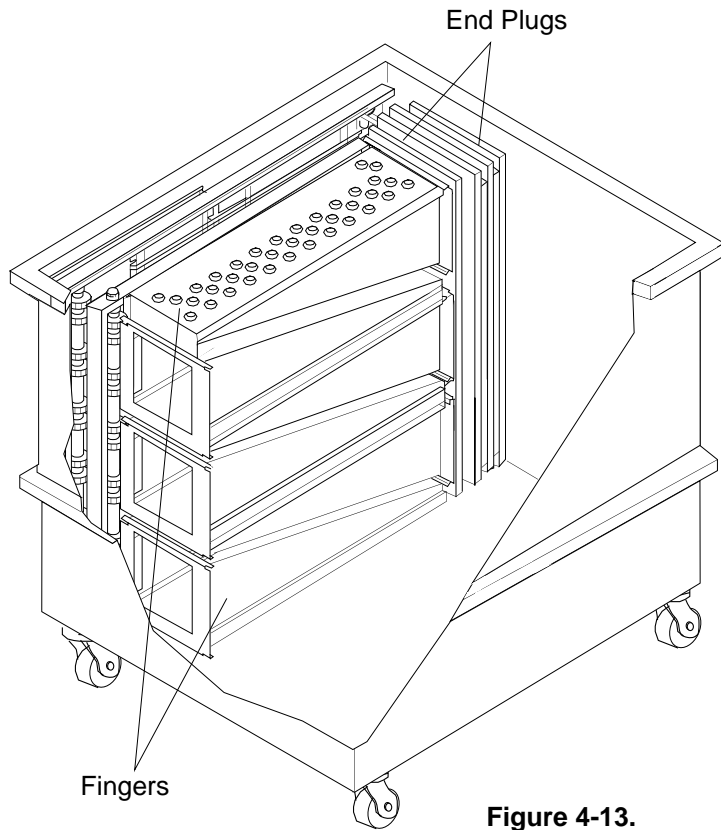

Figure 4-13.

b. Place the end plugs in the soak bin as shown in Figure 4-13.

Then place the fingers in the soak bin by placing the slanted sides of the fingers together to conserve space as shown in Figure 4-13.

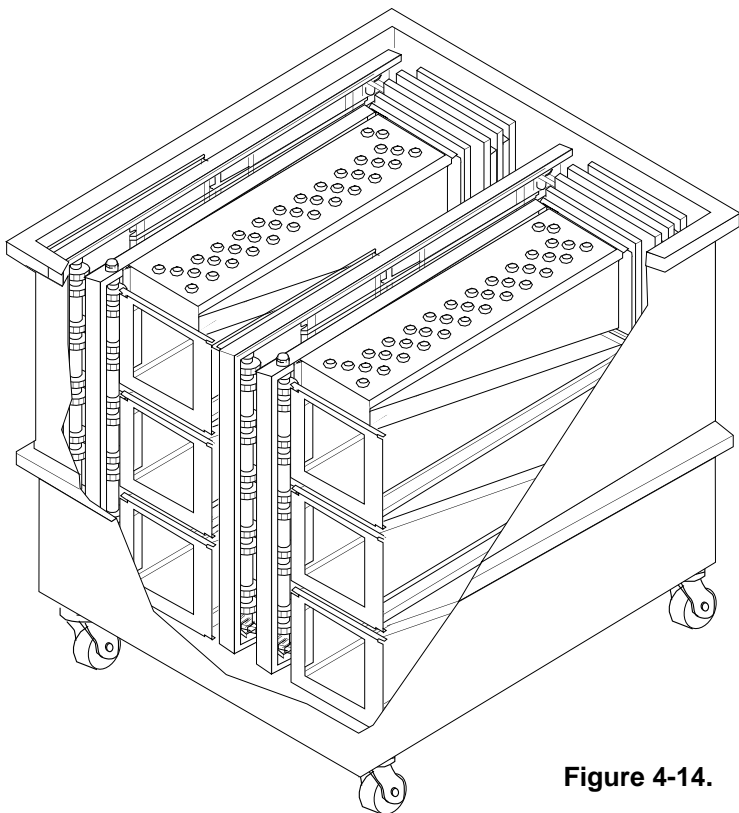
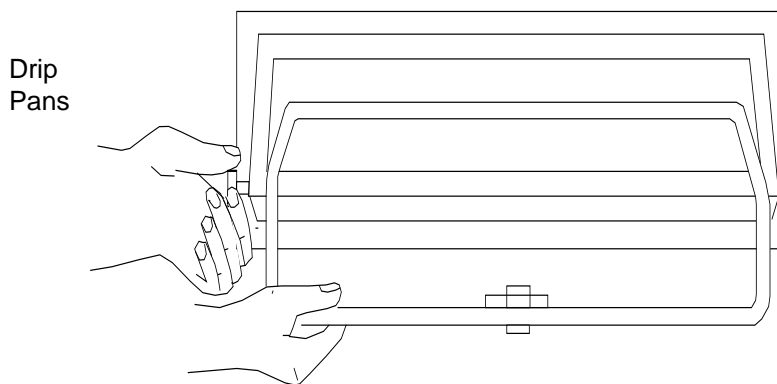

Figure 4-14.

3. Repeat Steps a and b for the second oven. Refer to Figure 4-14.

Windows (Blank plates
placed under windows)



4. Place the drip pans from both ovens on top of the fingers, then the blank plates and last place the windows on the drip pans so they will not be damaged. Refer to Figure 4-15.

5. Allow to soak overnight.

Figure 4-15.

E. Cleaning parts that were soaked overnight.

Cleaning takes 2 people. One to clean the oven and one to clean the parts.

You will need:

- Boots
- Rubber Gloves
- Steel brush
- Kote Spray
- Squirt bottle filled with water
- Towels
- Grill pads
- Black pad
- Putty knife

NOTE: Before cleaning parts from soak bin cover any dishes or other equipment or pans in the dish area with plastic sheets. Prepare an area for spraying parts with Kote.

1. Clean windows first.

2. Scrub crumb pans, end plugs, drip pans and blank plates. Then run them through the dish machine, dry thoroughly and then spray with Kote.

3. Clean conveyor by unfolding carefully on dish sink counter. Rinse away any loose material from conveyor chain and if needed scrub with small steel brush. Dry the conveyor thoroughly and spray with Kote.

SECTION 4
MAINTENANCE

4. Cleaning fingers.

WARNING: Clean one finger at a time. Only one finger at a time should be disassembled because the parts of the fingers are not interchangeable.

- Finger assemblies are made up of an outer plate, inner plate and finger manifold as shown in Figure 4-16.
- When cleaning finger assemblies check one assembly at a time to see if the inner plate needs scrubbing. Disassemble only one finger at a time and after cleaning the inner plate and the manifold, reassemble the finger before disassembling the next finger.

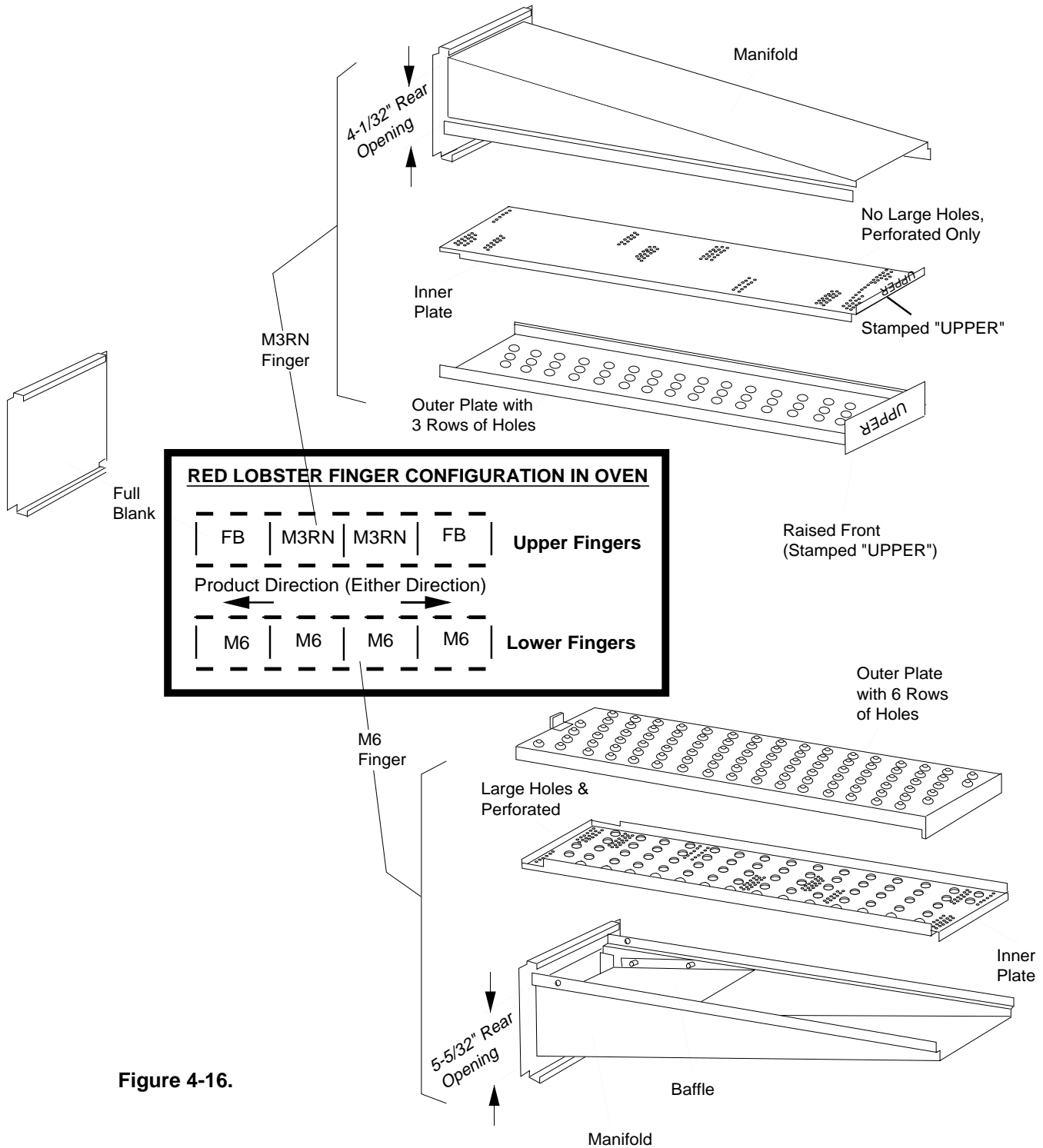

Figure 4-16.

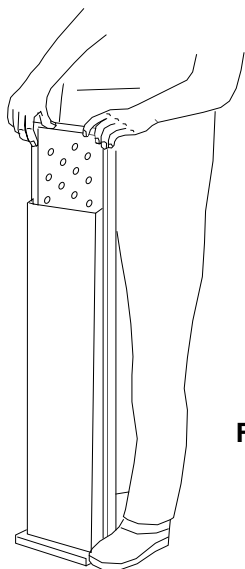

Figure 4-17.

- c. Place fingers in an upright position to remove the outer plate. Gently step on the lip of the finger and pull the outer plate off.

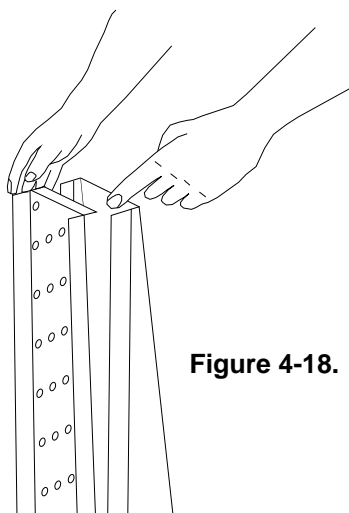
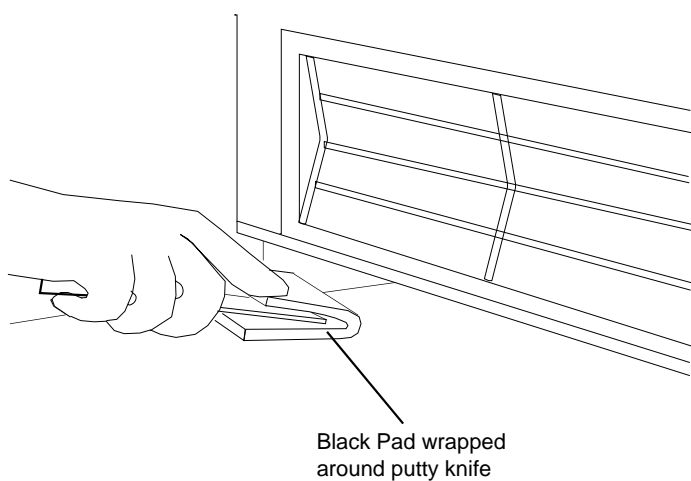

Figure 4-18.

- d. To remove the inner plate, pull plate out and then up.
- e. Scrub the parts using the black pad if necessary and then run the parts through the dish machine and dry thoroughly. Spray the finger parts with Kote.
- f. Reassemble the inner plate, keep your fingers clear so you won't pinch them. The inner plate of a finger will only go on in one way because of its design. Refer to Figure 4-18.
- g. Replace the outer plate by placing your hands flat on the top of the plate and pushing down. Keep your fingers clear so you won't pinch them. Refer to Figure 4-17.



Black Pad wrapped
around putty knife

Figure 4-19.

F. Cleaning interior of oven.

1. Use the squirt bottle to spray the inside of oven with water. Do not spray into fan areas.
2. Wipe off all interior surfaces with damp grill pad. Use your black pad and putty knife to loosen any baked on material. Refer to Figure 4-19.

SECTION 4 MAINTENANCE

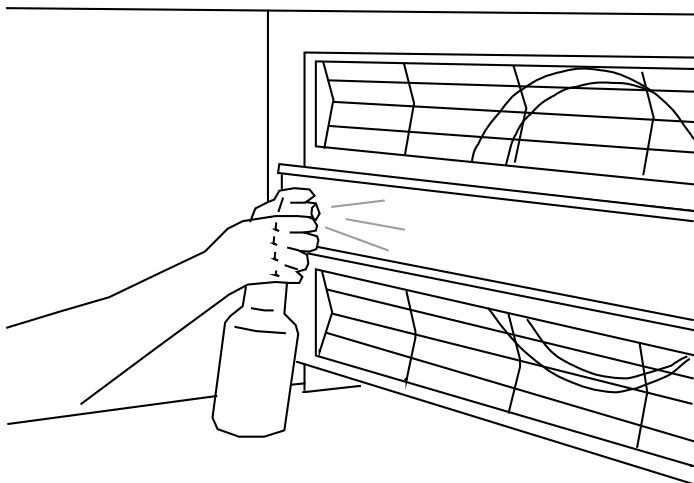

Figure 4-20.

3. Clean the oven exterior as needed and dry the oven inside and out.

4. Spray all interior surfaces, **except the fan area**, with Kote. Cover all areas well. Refer to Figure 4-20. Be sure the oven is dry before spraying. Kote does not work well on wet surfaces. A thorough spraying with Kote is your best tool for easy cleaning because it prevents grease splatters from baking on. Areas that are not sprayed with Kote will need hard scrubbing rather than light cleaning at the next weekly cleaning.

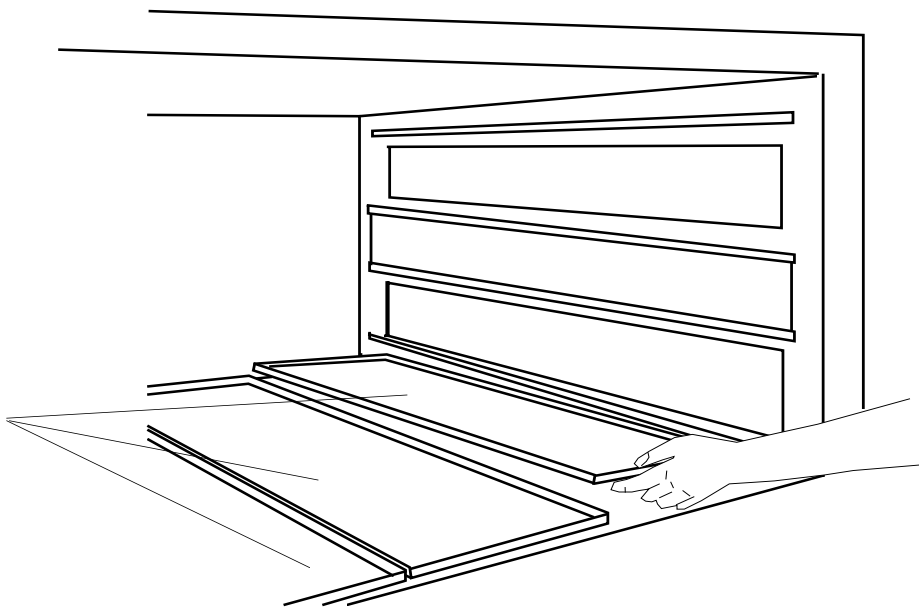

Figure 4-21.

G. Oven reassembly.

1. Replace the 3 drip pans into bottom of oven. Refer to Figure 4-21.

2. Reassemble bottom fingers into oven first by pushing in on their back side.
Refer to Figure 4-16 for correct finger position in oven.

IMPORTANT: Only M6 fingers fit in the bottom row. All M3 finger cover plates have extended lips at front. This extended lip will not allow these fingers to be installed in the bottom row.

a. **IMPORTANT:** When inserting fingers the tab on the outer plate must be in the groove as shown in the illustration. There is a blocking tab on the outside of the groove which will prevent inserting the finger in the groove if the outer plate is moved away from the flange of the finger manifold. Refer to Figure 4-22.

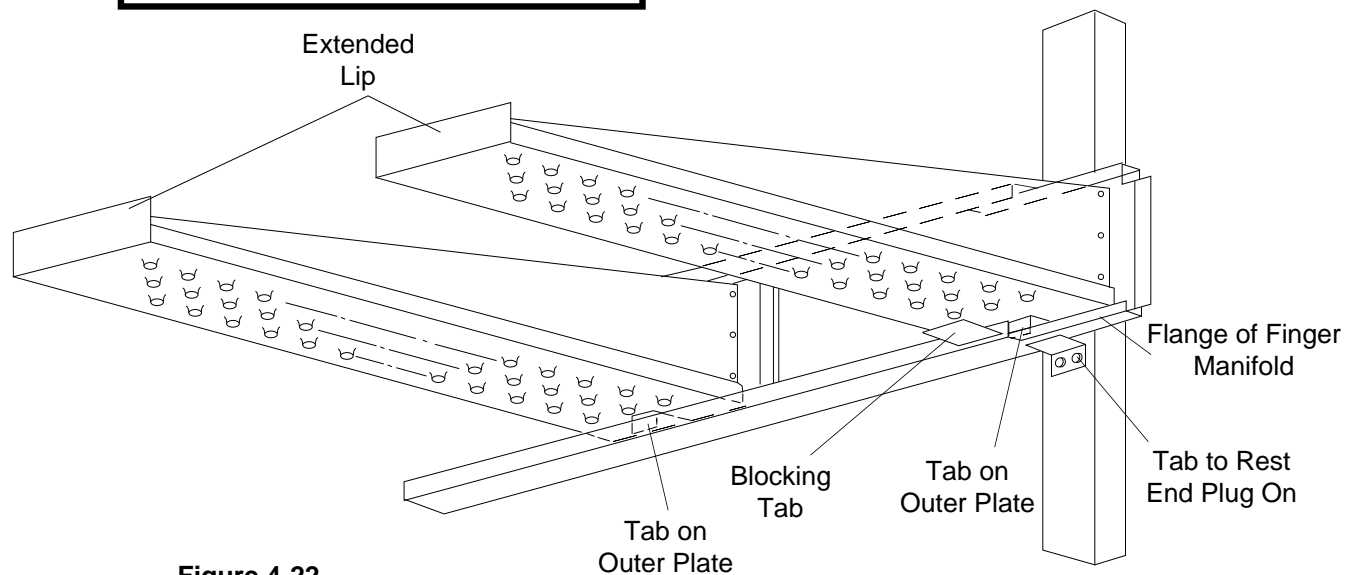

Figure 4-22.

SECTION 4
MAINTENANCE

b. Install fingers and blank plates correctly with edges interlocked. There must be no opening between edges of filler plates. Refer to Figure 4-23.

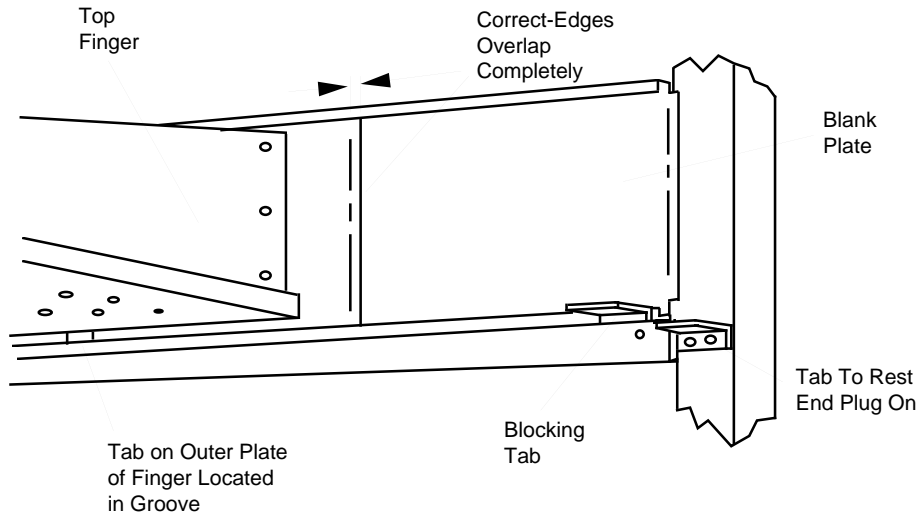
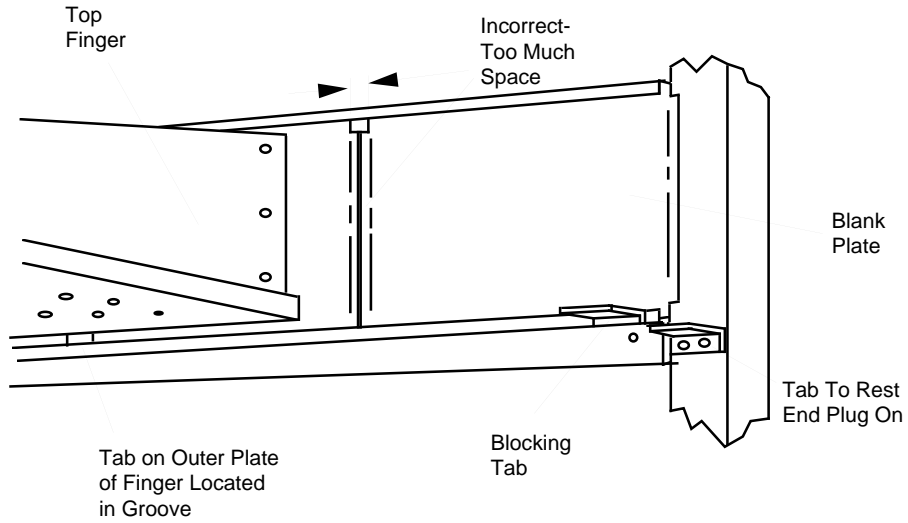
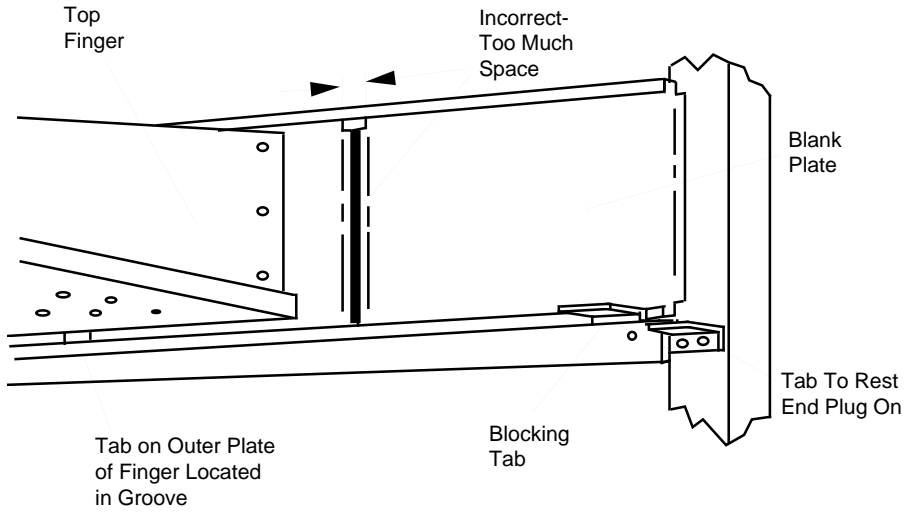

Figure 4-23.

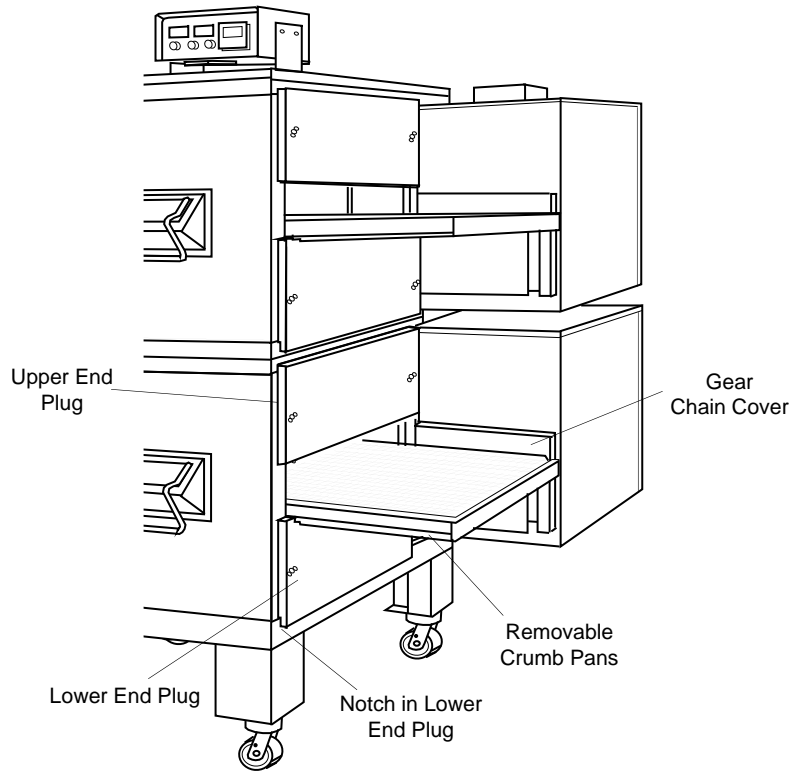

Figure 4-24.

3. Reassemble lower end plugs to both ends of oven. Refer to Figure 4-24. Notice that the lower end plugs have a notch in them. Position the lower end plugs against the oven and then up into place. Use the wing nuts to secure the end plugs to the oven.

4. Reassemble top fingers and blank plates into oven. Refer to Figure 4-16, 4-22 & 4-23.

5. Spray Kote on any areas that may have been wiped off.

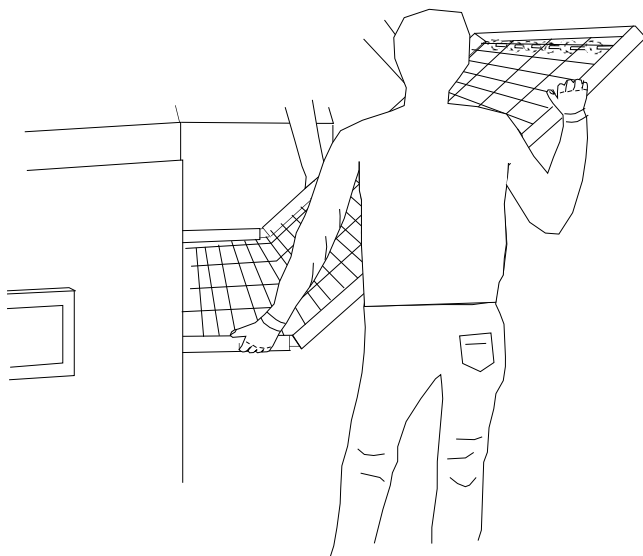
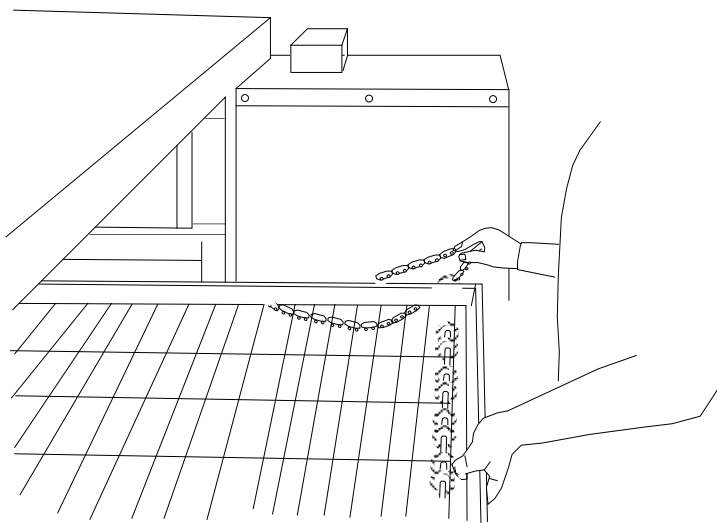

Figure 4-25.

6. Using 2 people install the conveyor.

a. Lift the conveyor and start it into the drive end of the oven. The drive end of the oven is the end with the machinery compartment attached. Slide the conveyor along the side guides until the crumb tray slide falls into place at the opposite end.

**SECTION 4
MAINTENANCE**



b. Attach drive chain by lifting conveyor and attaching drive chain to conveyor drive sprocket.

Figure 4-26.

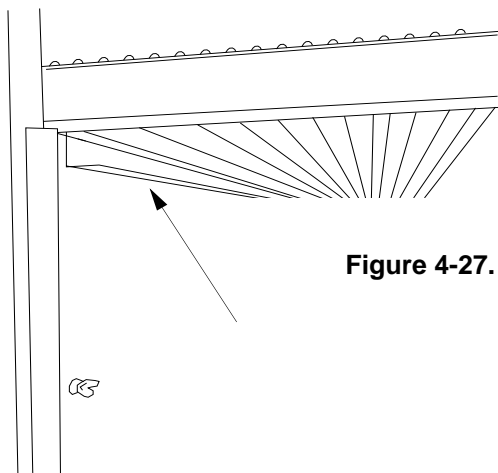

c. The angle plate located on the underside of the conveyor must be against the lower end plug. This is true on both ends of oven.

Figure 4-27.

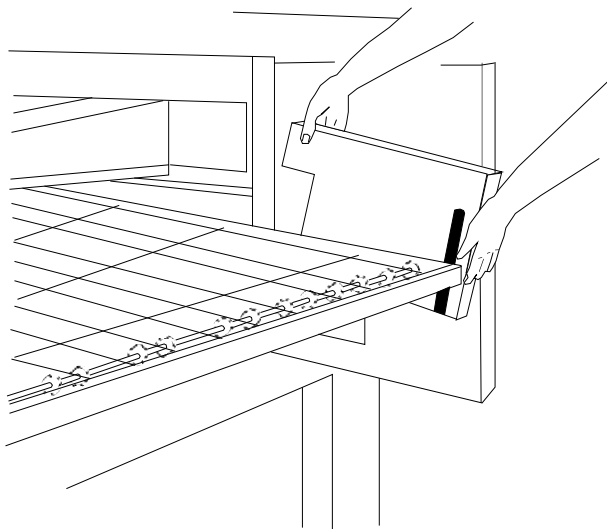

d. Reassemble conveyor drive chain cover.

Figure 4-28.

e. Checking conveyor belt tension.

NOTE: Oven conveyor belt must be cool when adjusting belt. **Do not adjust belt if HOT.**

AA. With the conveyor assembly in the oven, stand at one end of conveyor and check tension by lifting the conveyor belt at the center of the oven chamber opening. The belt should not lift higher than 3 to 4 inches (76mm to 102mm).

BB. Adjust conveyor chain tension screws (located on left end of oven) for the 3" to 4" deflection shown in the photo.

CC. If conveyor belt **is still not** under proper tension recheck your adjustment of the conveyor tension screws. If correct adjustment is not possible call your service agency.

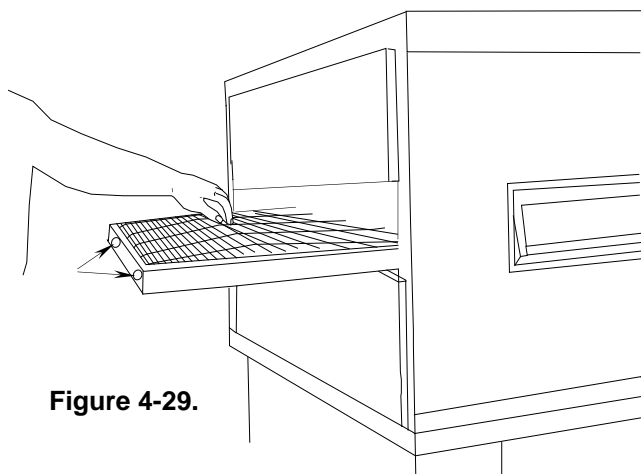

Figure 4-29.

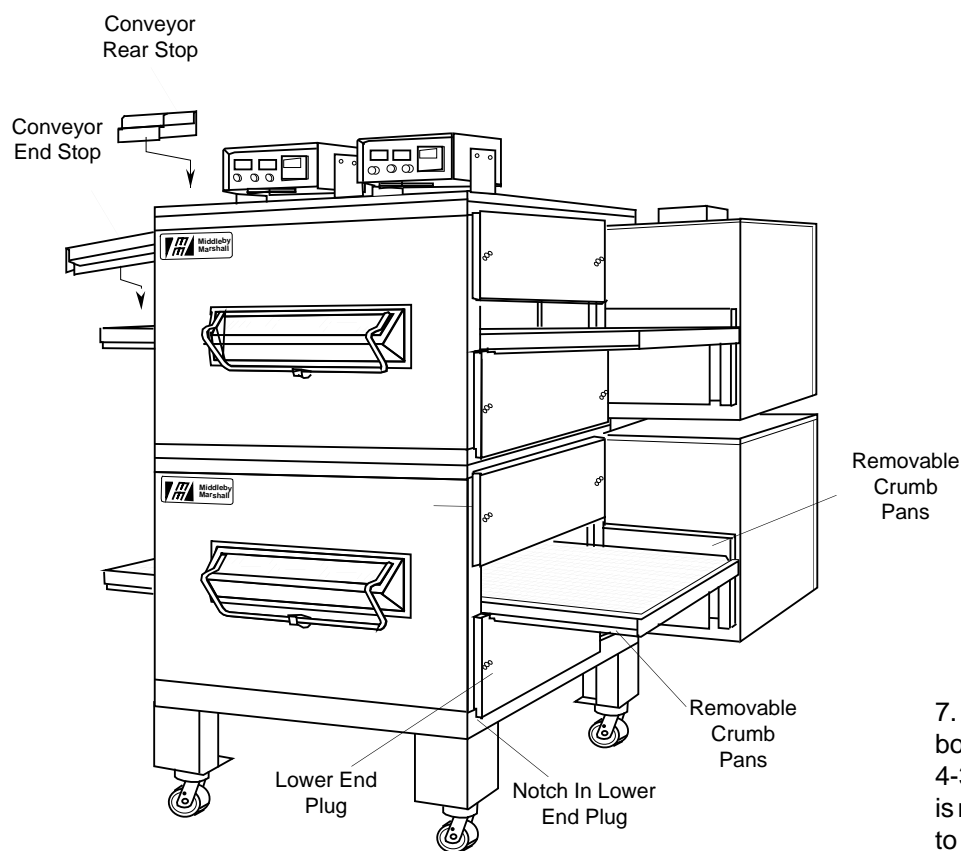

Figure 4-30.

f. Reinstall conveyor end stop and rear stop.

7. Reassemble upper end plugs to both ends of oven. Refer to Figure 4-30. Notice that the upper end plug is not notched. Secure the end plugs to oven using the wing nuts.

SECTION 4 MAINTENANCE

III. MAINTENANCE - EVERY 3 MONTHS

NOTE: It is recommended that the 3 Month Maintenance schedule be performed by an Authorized Middleby Marshall Service Agent.

CAUTION:
All electrical power should be shut OFF
and locked out or tagged out before attempting
maintenance in steps "A" thru "D".

A. Cleaning fan motor

NOTE: It is recommended that step "A" thru "D" be performed by an authorized Middleby Marshall Service Agent.

To gain access to the fan motor, open the machinery compartment door by removing three screws. Clean the fan motor, burner motor, conveyor motor and the surrounding area using either compressed air or CO₂. Thoroughly blow out the motor compartment and vents inside the motor. Failure to do this could cause premature failure of the electric motor.

B. Electrical terminals

Open machinery compartment door by removing three screws from the door. Tighten all electrical terminal screws on all components. Also tighten electrical terminal screws in the remote controls.

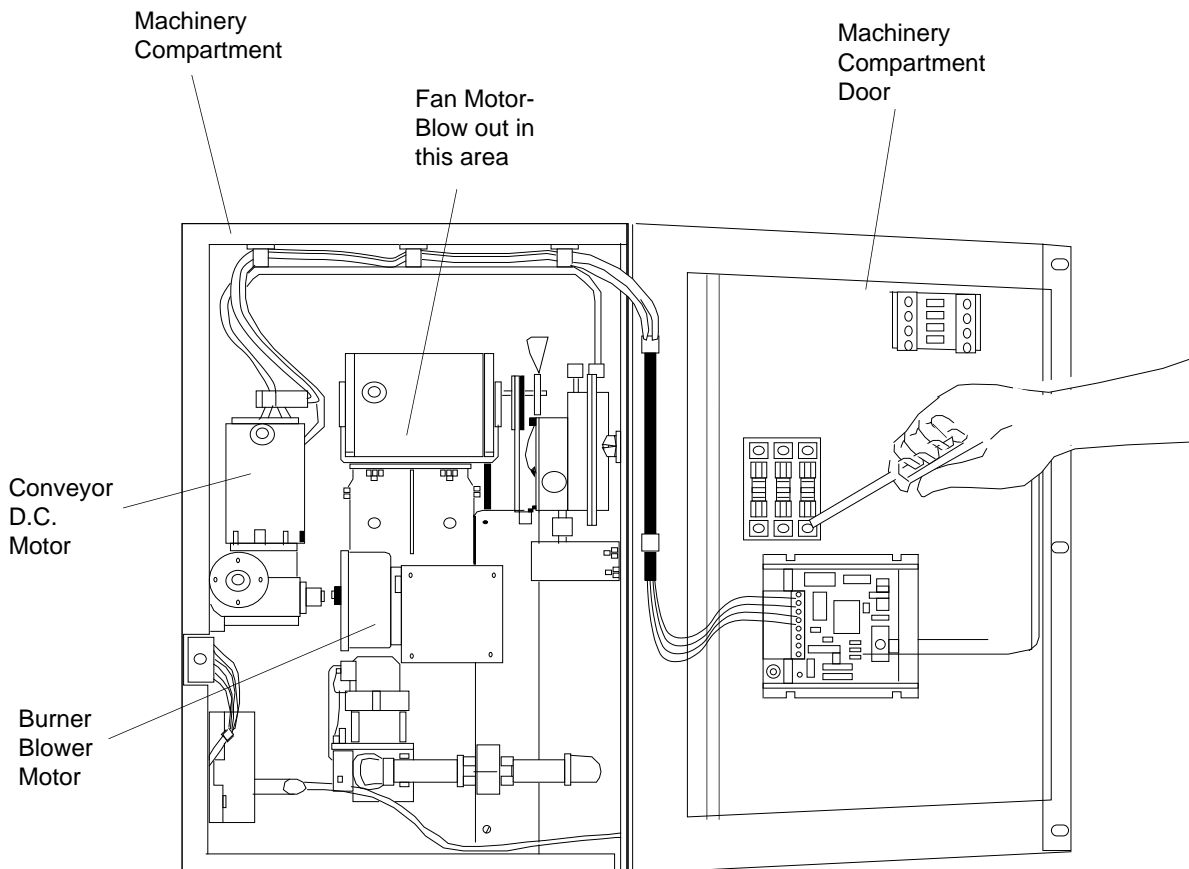
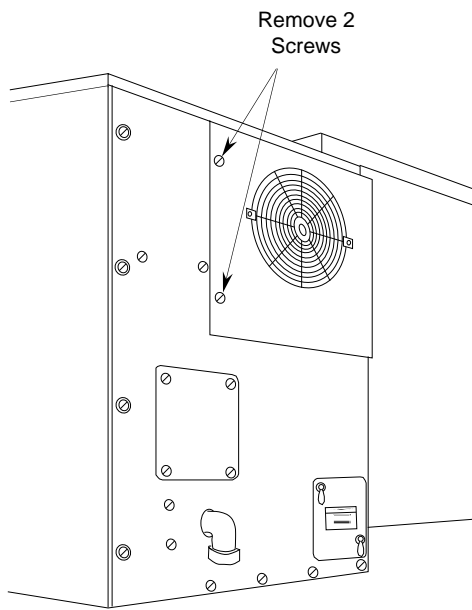

Figure 4-31.



C. Checking and/or replacing main blower fan belt

1. Check the main blower fan belt for proper tension and wear. To gain access you must remove the two (2) screws on the bottom lip of rear shroud along with the two (2) screws on the cooling fan guard plate.

Figure 4-32.

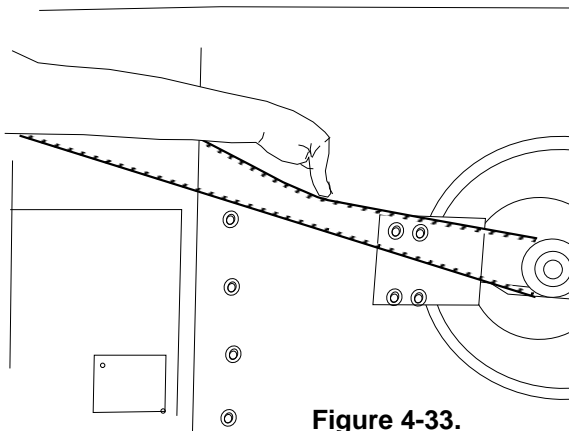

2. The fan belt should have no less than 1" deflection at the center and have no cracks or excessive wear. A spare belt is located inside the machinery compartment. Over tightening the belt will cause premature bearing failure and possible vibration problems.

SECTION 4 MAINTENANCE

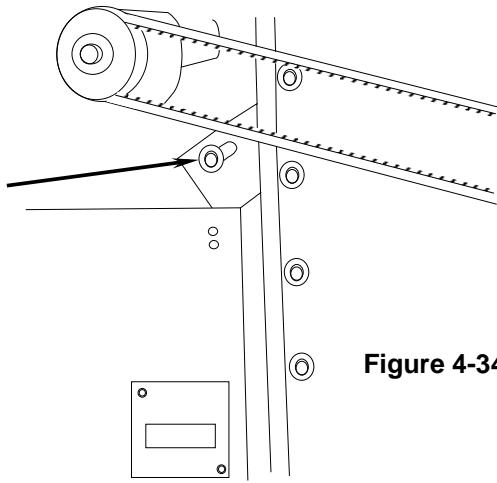

Figure 4-34.

3. If belt is loose or to replace belt loosen the tension locking bolts on the motor mounting bracket. Next pull back on the motor, do not over tighten or fan bearings may be damaged. Retighten locking bolts.

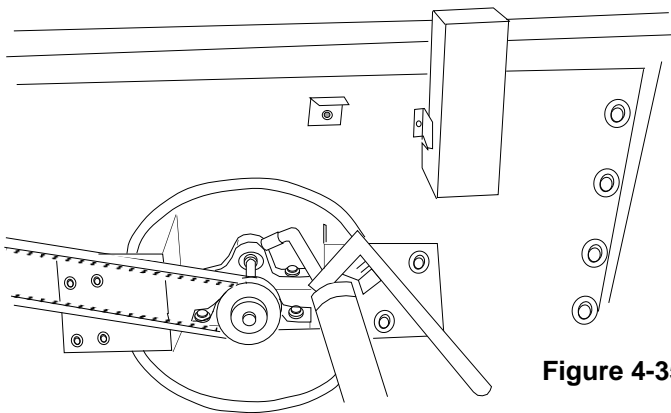

Figure 4-35.

D. Main Blower Fan Shaft Bearing Lubrication

Grease the 2 main blower fan shaft bearings using a special high temperature grease (MM P/N 17110-0015 Lithium base higher temperature grease). **ONLY ONE PUMP** of grease gun in each bearing is required. Over greasing will damage bearing seals which will accelerate grease loss and shorten bearing life. Wipe off any excess grease on and around the bearing. Replace rear shroud, oven will not operate without the rear shroud in place.

IV. MAINTENANCE - EVERY 6 MONTHS

NOTE: It is recommended that the 6 Month Maintenance schedule be performed by an Authorized Middleby Marshall Service Agent.

CAUTION:
All electrical power should be shut OFF and locked out or tagged out before attempting maintenance in steps "A" thru "C".

- A. Check brushes on D.C. conveyor motor, when worn to less than 3/32" (2.2mm) replace.
- B. Burner nozzle and electrode assembly should be cleaned and inspected. Also check your oven venting system.
- C. Check conveyor shaft bushings and spacers. Replace them if they are worn.

MAINTENANCE PARTS

The following parts were shipped inside the control compartment of your oven to be used for preventive maintenance or as spares. It is recommended that whenever you use one of these parts you should order a replacement from your local authorized Middleby Marshall Parts Distributor.

QUANTITY	MIDDLEBY MARSHALL PART NUMBER	DESCRIPTION
2	28154-0003	TRM 9 Amp Fuse (See Figure 6-3) Fan Belt (Refer to previous page for fan belt replacement.
1	22181-0034	

NOTES:

SECTION 5 TROUBLESHOOTING

PROBLEM PRODUCTS OVERCOOKED OR UNDERCOOKED

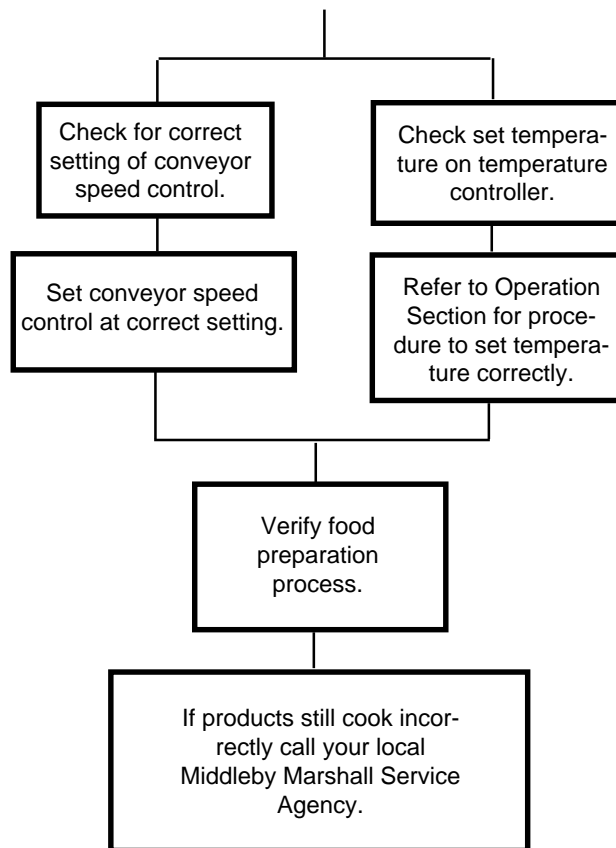

SECTION 5
TROUBLESHOOTING

PROBLEM
OVEN WILL NOT HEAT

Check to see if both blower switch and heat switch are in the "I" (on) position

If still no heat call your local Middleby Marshall Service Company.

PROBLEM
OVEN BLOWER AND CONVEYOR OPERATE
BUT THE OVEN IS NOT HEATING

If the oven does not reach 200°F (93°C) within 15 minutes the temperature controller will flash "FAILSF". To reset the temperature controller turn the blower switch off for 30 seconds.

Try restarting the oven again. If the oven will not heat call your local Middleby Marshall Service Agency.

PROBLEM
CONVEYOR WILL NOT HOLD PROPER
SPEED OR WILL NOT RUN AT ALL

Check if conveyor is jammed
on something in oven.

Check for proper tension of conveyor belt.
Refer to Maintenance Section for checking
procedure.

Check that drive sprocket
is tight.

If conveyor still will not run contact your local
Middleby Marshall Service Agency.

PROBLEM
OVEN WILL NOT TURN ON WHEN THE SWITCHES
ARE TURNED ON

Check if circuit breakers are
turned on.

Check if cables at remote control and at top of
machinery compartment are attached.

CAUTION:

***If cables need to be attached
turn the circuit breakers off
before attaching the cables.***

If oven still will not respond contact your local
Middleby Marshall Service Agency.

PROBLEM
BLOWER MOTORS RUNNING BUT LITTLE
OR NO AIR AT FINGERS

Fingers assembled incor-
rectly after cleaning

SECTION 6 PARTS LIST

FIGURE NO.	DESCRIPTION	PAGE NO.
6-1	Oven Panels, Window and Legs Exploded Drawing	60
6-2	Air Finger Exploded Drawing	62
6-3	Control Panel Exploded Drawing	64
6-4	Blower and Shroud Exploded Drawing	66
6-5	Conveyor Exploded Drawing	68
6-6	Gas Burner and Piping Assembly Exploded Drawing	70
6-7	Machinery Compartment Exploded Drawing	72
6-8	Electric Oven Electrical Panel Drawing	74
6-9	Junction Box and Export Transformer Exploded Drawing	76

NOTE: Throughout Section 6 parts lists the following abbreviations are used:

A/R = Quantity as required

N/A = Does not apply

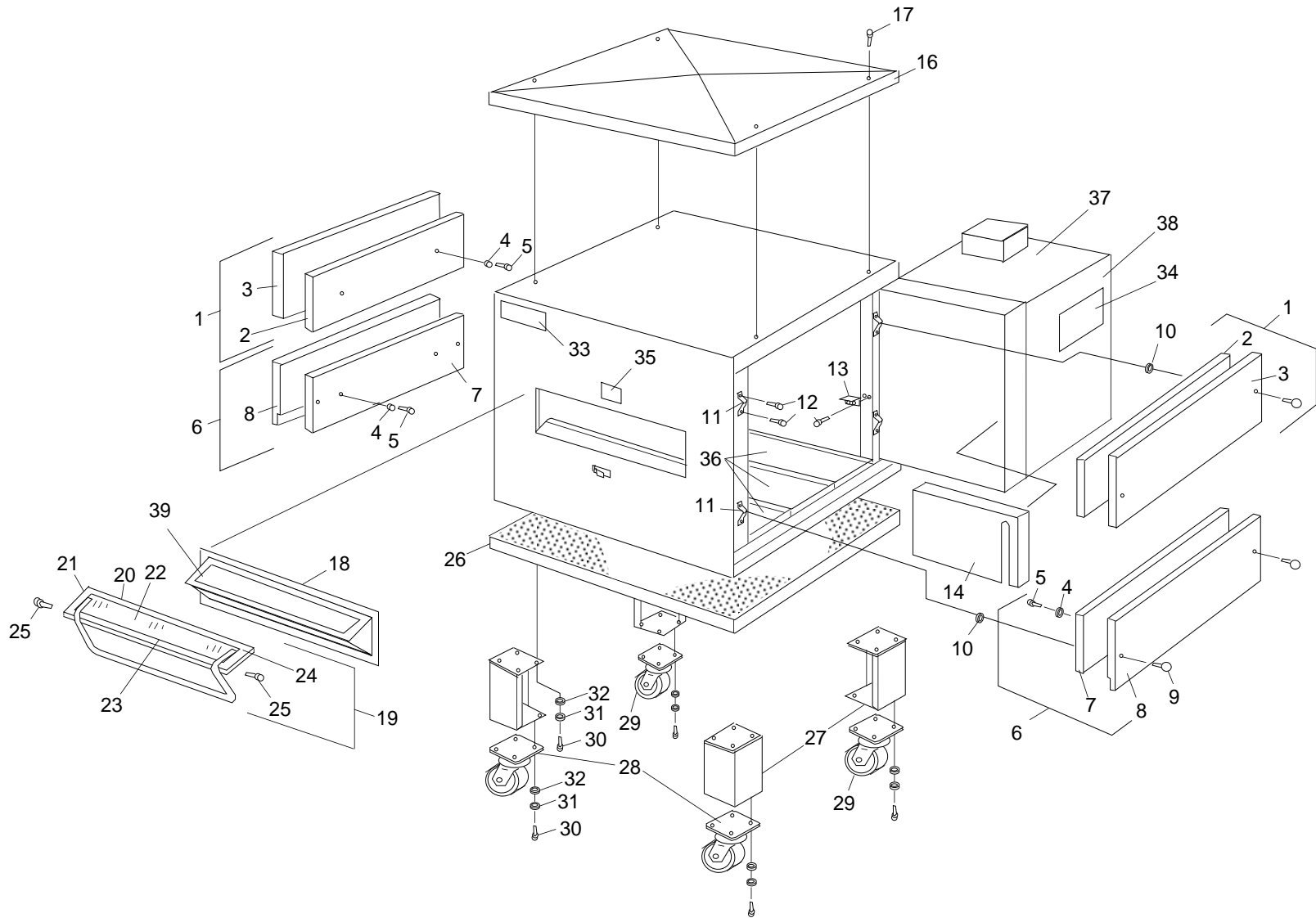

69

FIGURE 6-1
OVEN PANELS, WINDOW AND LEGS

OVEN PANELS, WINDOW AND LEGS

ITEM NO.	QTY.	PS200-R68 PART NO.	PS220-R68 PART NO.	PS224-R68 PART NO.	DESCRIPTION
1	2	49400-0160	31314	49400-0245	END PLUG ASSEMBLY - UPPER
2	1	35900-0285	35900-0371	35900-0436	INNER PANEL - END PLUG
3	1	30261	30420	35900-0245	WELDMENT - OUTER PANEL UPPER END PLUG
4	2	21416-0005	21416-0005	21416-0005	FLAT WASHER SS 1/4"
5	2	2000346	2000346	2000346	SCREW SS 1/4-20 x 1/2"
6	2	49400-0161	49400-0244	49400-0252	END PLUG ASSEMBLY - LOWER
7	1	35900-0286	35900-0472	35900-0463	INNER PANEL - END PLUG
8	1	30264	30514	30531	WELDMENT - OUTER PANEL - LOWER END PLUG
4	2	21416-0005	21416-0005	21416-0005	FLAT WASHER SS 1/4"
5	2	2000346	2000346	2000346	SCREW SS 1/4-20 x 1/2"
9	8	21296-0002	21296-0002	21296-0002	WING SCREW x 1/4-20 x 1/2"
10	8	21182-0006	21182-0006	21182-0006	NUT, PUSH TYPE, BOLT RETAINER, SS
11	8	30278	30278	30278	MOUNTING BRACKET - END PLUG
12	A/R	21296-0005	21296-0005	21296-0005	SCREW, WASHERHEAD 10-16 x 3/4", SS
13	4	35900-0043	35900-0043	35900-0043	SHELF BRACKET - UPPER END PLUG
14	1	35900-0314	35900-0314	35900-0314	CHAIN GUARD-RIGHT END DRIVE
14	1	30756	30756	30756	CHAIN GUARD-LEFT END DRIVE
16	1	31357	31261	30878	OVEN TOP
17	4	21256-0008	21256-0008	21256-0008	SCREW 10-32 x 3/8" SS
18	1	31382	31382	31382	WINDOW MOUNTING FRAME, L.H.
18	1	30280	30280	30280	WINDOW MOUNTING FRAME, R.H.
19	1	30285	30285	30285	GLASS DOOR ASSEMBLY
20	1	30286	30286	30286	GLASS TOP FRAME
21	1	17130-0006	17130-0006	17130-0006	SEALANT, SILICON RUBBER, 11OZ.
22	1	22140-0017	22140-0017	22140-0017	TEMPERED GLASS
23	1	33300-0273	33300-0273	33300-0273	TUBE, GLASS FRAME, HINGE
24	1	30287	30287	30287	GLASS DOOR FRAME WELDMENT
25	2	34121-0003	34121-0003	34121-0003	SCREW, THUMB PIVOT
26	1	37900-0025	37900-0184	37900-0196	BASE PAD
27	4	37900-0102	37900-0102	37900-0102	LEG, 6"
28	2	22290-0009	22290-0009	22290-0009	SWIVEL CASTER W/BRAKE
29	2	22290-0010	22290-0010	22290-0010	SWIVEL CASTER
30	A/R	220373	220373	220373	HEX BOLT, 3/8"-16 X 1"
31	A/R	21426-0001	21426-0001	21426-0001	SPLIT WASHER, 3/8"
32	A/R	21416-0001	21416-0001	21416-0001	FLAT WASHER, 3/8"
33	1	22500-0021	22500-0021	22500-0021	PLATE, MM
34	1				OPERATING INSTRUCTIONS, GAS
35	1	22500-0041	22500-0041	22500-0041	LABEL, CAUTION HOT SURFACE
36	3	35900-0387	35900-0437	35900-0467	DRIP PANS
37	1	30258	30258	30258	CONTROL ENCLOSURE, TOP ASSEMBLY
38	1	30256	30256	30256	CONTROL ENCLOSURE DOOR
39	per ft.	22420-0005	22420-0005	22420-0005	WINDOW GASKET, SILICON, PER FOOT

62

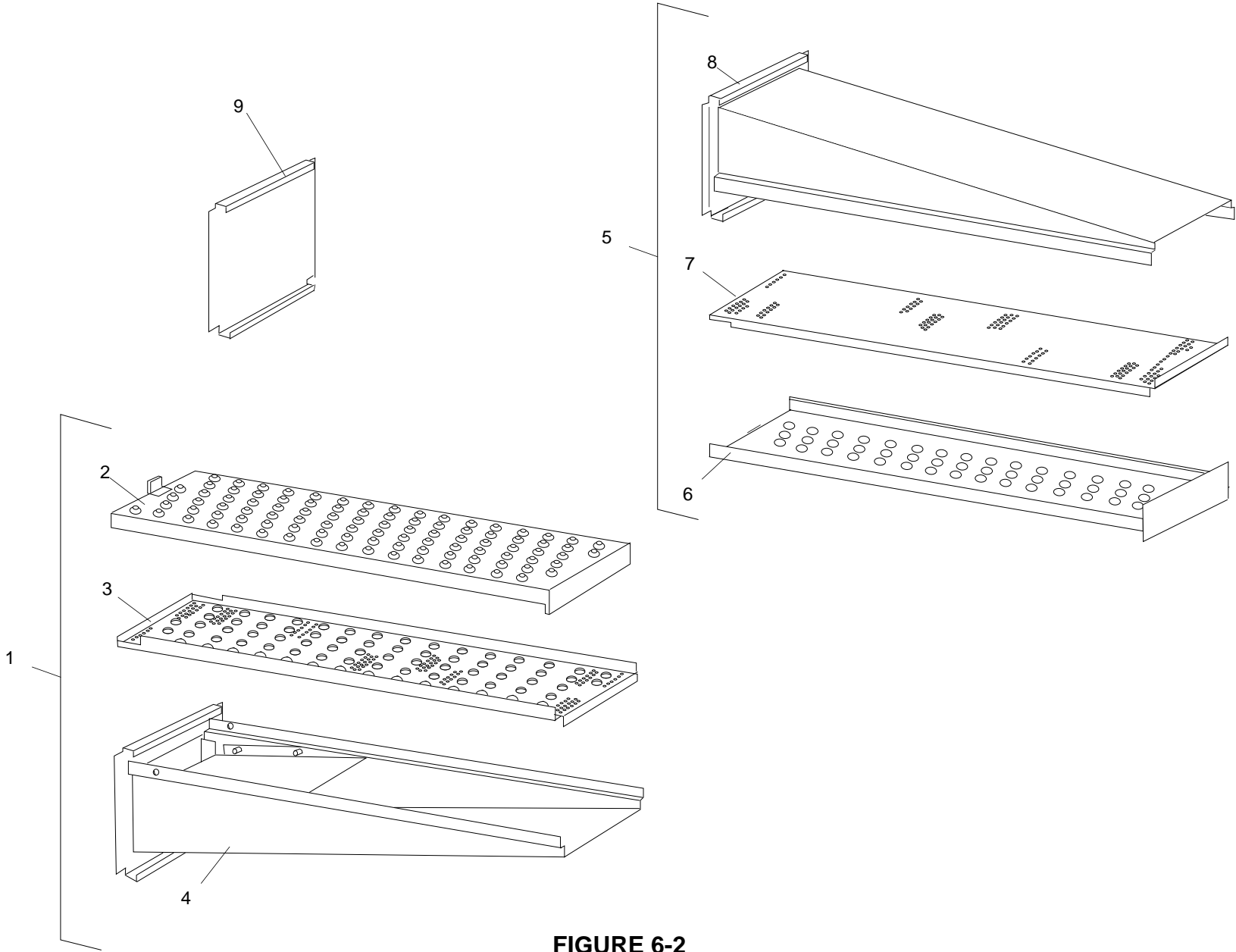

**FIGURE 6-2
AIR FINGERS**

AIR FINGERS

ITEM NO.	PS200-R68 PART NO.	PS220-R68 PART NO.	PS224-R68 PART NO.	DESCRIPTION
1	49400-0146	49400-0242	49400-0249	FINGER ASSEMBLY SS M6
2	37900-0051	37900-0172	37900-0217	COVER PLATE M6
3	37900-0123	37900-0209	37900-0219	INNER PLATE SS - SUPER FINGER
4	49400-0270	48400-0274	49400-0272	FINGER MANIFOLD ASSEMBLY SS
5	49400-0145	49400-0243	49400-0250	UPPER FINGER ASSEMBLY M3RN, NON-COLUMNATING SS
6	37900-0230	37900-0210	37900-0220	COVER PLATE M3
7	35900-0291	35900-0471	35900-0477	INNER PLATE, NON-COLUMNATING SS w/NO ROWS OF HOLES
8	49400-0269	49400-0273	49400-0271	FINGER MANIFOLD ASSEMBLY, SS, 4.2" clearance in oven
9	35900-0287	35900-0287	35900-0287	FULL BLANK SS

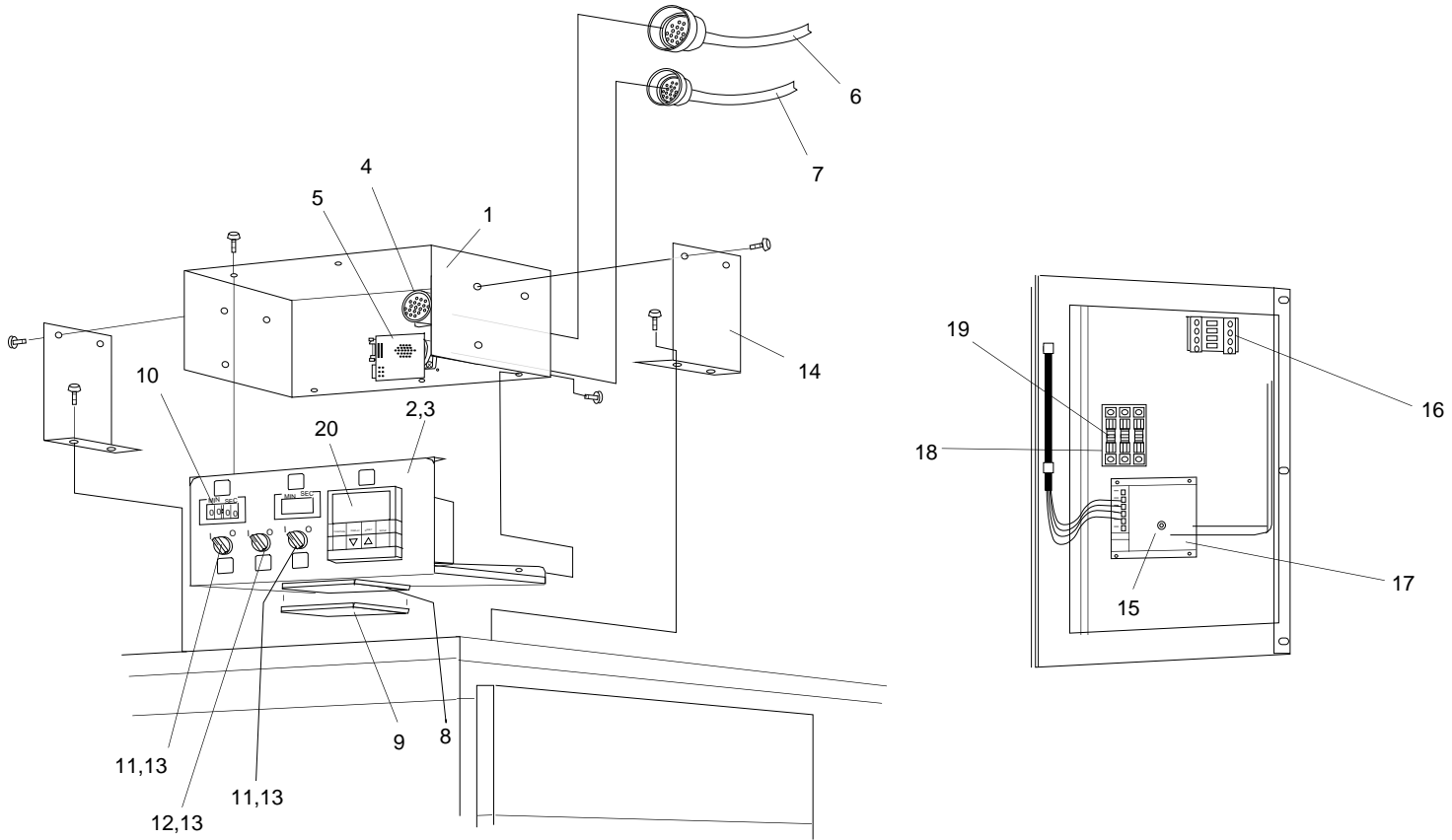

**FIGURE 6-3
CONTROL PANEL**

CONTROL PANEL

ITEM NO.	QTY.	PART NO.	DESCRIPTION
1	1	31120	CONTROL PANEL ENCLOSURE
2	1	31118	FACE PANEL, REMOTE
3	1	31119	LABEL, FACE PANEL, REMOTE
4	1	32340	RECEPTACLE CONTROL BOX ASSEMBLY AC
5	1	32341	RECEPTACLE/BOARD ASSEMBLY DC
6	1	32142	CABLE AND RECEPTACLE ASSEMBLY 16 PIN AC
7	1	32141	CABLE AND RECEPTACLE ASSEMBLY 12 PIN DC
8	1	31370	FAN, TUBE AXIAL
9	1	3000330	FILTER/GUARD, FAN PLASTIC
10	1	32339	THUMBWHEEL ASSEMBLY, SPEED CONTROL
11	2	28021-0062	SWITCH KNOB - BLUE
12	1	28021-0063	SWITCH KNOB - RED
13	3	27060-0012	CONTACT BLOCK W/BASE
14	2		LEG, CONTROL PANEL ENCLOSURE
15	1	22500-0131	LABEL - TEMPERATURE DOT 170°F (77°C)
16	3	28041-0008	CONTACTOR, DP 25A, 120V COIL 4P
17	1	42810-0133	CONVEYOR SPEED CONTROL
18	1	27021-0011	FUSEBLOCK, 30A, 600V, 5P Class M
19	1	28154-0003	FUSE TM DELAY 0.9A, 250V
20	1	42810-0138	TEMPERATURE CONTROLLER

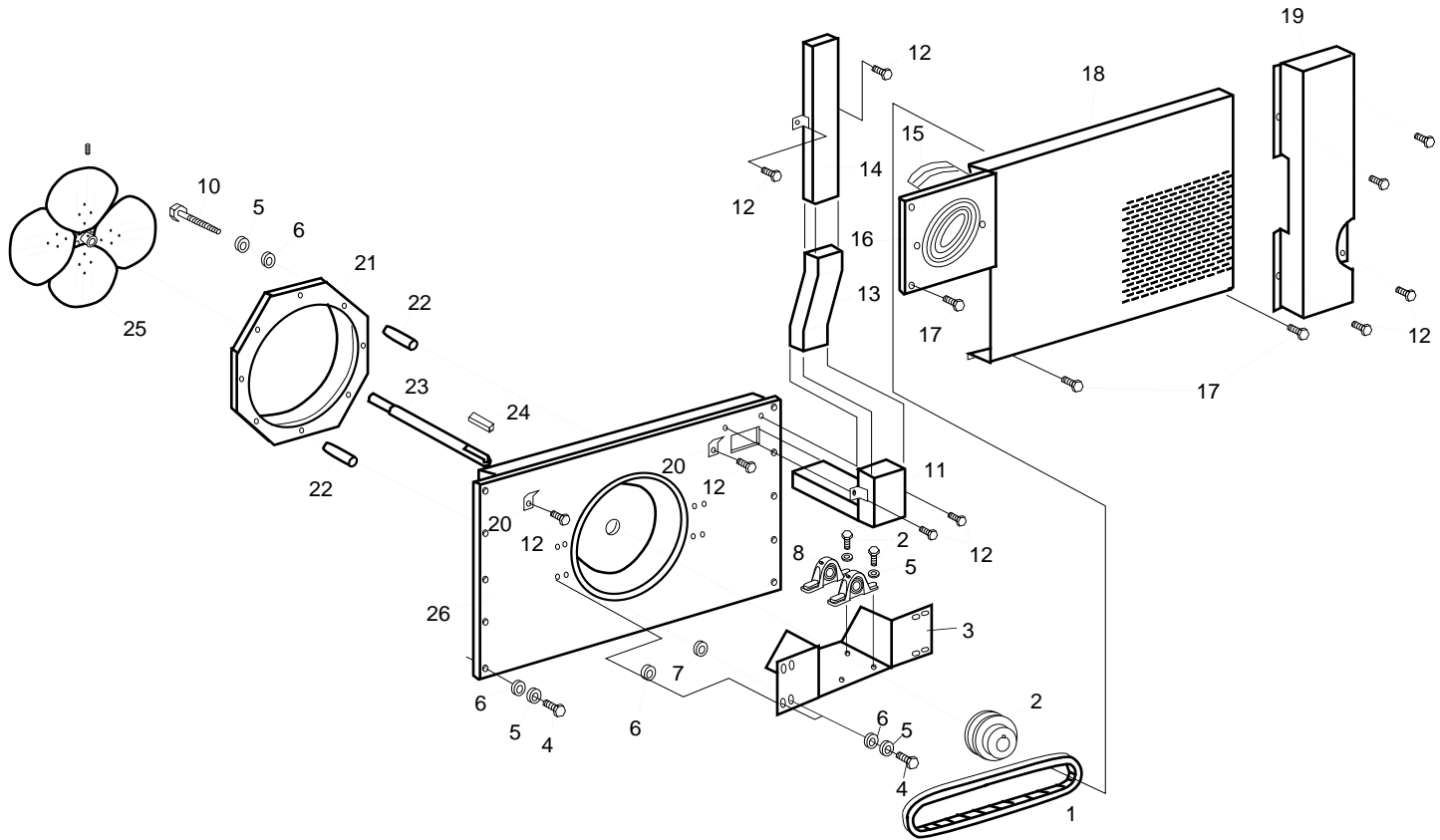
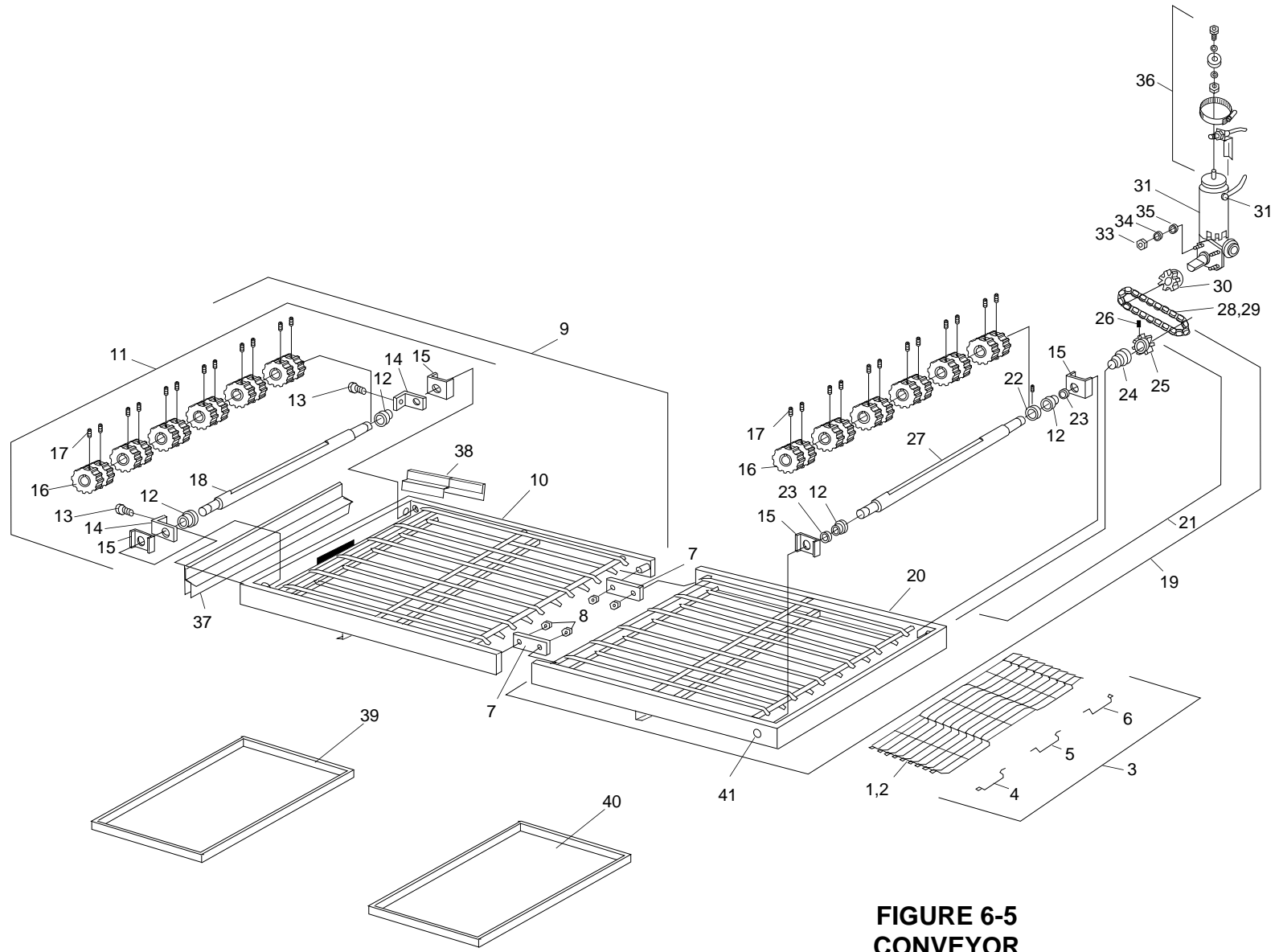

FIGURE 6-4
BLOWER AND SHROUD

BLOWER AND SHROUD

ITEM NO.	QTY.	PART NO.	DESCRIPTION
1	1	22181-0034	BELT, V-NOTCHED
2	1	22230-0073	PULLEY, 60 HZ OVENS, 5/8"B AK32
3	1	37900-0147	WELDMENT, REAR BRG BRACKET SS RED LOB
4	16	220373	BOLT 3/8"-16 x 1-1/2" SS HX
4A	A/R	17110-0017	NEVER SEIZE LUBRICANT - USED ON ITEMS 4 & 10 - APPLIED TO THREADS BEFORE REINSTALLING
5	A/R	21422-0001	SPLIT WASHER 3/8" SS
6	A/R	21416-0001	FLAT WASHER 3/8" SS
7	4	21419-0004	FLAT WASHER 3/8" SS SPECIAL
8	2	22072-0025	BEARING, PILLOW BLOCK 5/8"
10	A/R	21326-0002	BOLT 3/8"-16 x 5-1/2" SS HX
11	1	49400-0155	FLUE VENT
12	A/R	21292-0005	HX HD SCREW 10-16 x 3/4" SS
13	1	30039	WELDMENT, VENT OFFSET SS
14	1	30042	WELDMENT, DOUBLE VENT SS
15	1	37900-0162	COVER - REAR CNTRL PNL, for OVEN W/RIGHT END CONTROL PANEL SS
15	1	37900-0149	COVER - REAR CNTRL PNL, for OVEN W/LEFT END CONTROL PANEL SS
16	1	27470-0035	GUARD - COOLING FAN
17	4	21256-0009	SCREW TRUS CAP - 10-32 x 5/8", SS
18	1	37900-0161	REAR SHROUD, OVEN W/RIGHT END CONTROL PANEL
18	1	37900-0148	REAR SHROUD, OVEN W/LEFT END CONTROL PANEL
19	1	31434	SHROUD, VENT SS, LH & RH
20	2	30410	SHROUD HANGER BRACKET
21	1	22450-0217	RING ORIFICE FAN 16" DIA
22	A/R	35900-0108	STAND-OFF TUBE SS
23	1	35900-0232	SHAFT FAN DRIVE
24	1	21651-0010	KEY, SQ 3/16" X 3/16" 1-1/2" STL
25	1	27399-0003	FAN 16" DIAMETER
26	1	37900-0158	BACK WALL - GAS OVEN ONLY, OVEN W/RIGHT END CONTROL PANEL SS
26	1	37900-0144	BACK WALL - GAS OVEN ONLY, OVEN W/LEFT END CONTROL PANEL SS



**FIGURE 6-5
CONVEYOR**

Right Hand Drive Oven Shown. All components
are reversed for Left Hand Drive Oven

ITEM NO.	PS200-R68 PART NO.	PS220FS-R68 PART NO.	PS224-R68 PART NO.	DESCRIPTION
				CONVEYOR
				DESCRIPTION
				CONVEYOR ASSEMBLY W/BELT
				CONVEYOR ASSEMBLY W/BELT
				CONVEYOR BELT WIRE SS, 130"
				CONVEYOR BELT SECTION WIRE SS, 1 FT
				MASTER LINK KIT NOTE: MASTER LINK KIT INCLUDES ITEMS 4, 5, AND 6.
				MASTER LINK - RIGHT INCLUDED IN ITEM 4
				MASTER LINK - MIDDLE INCLUDED IN ITEM 4
				MASTER LINK - LEFT INCLUDED IN ITEM 4
				PIVOT PLATE - CONVEYOR FRAME
				LOCKNUT, HEX SS 3/8-20
				CONVEYOR FRAME ASSEMBLY - IDLER
				CONVEYOR FRAME WELDMENT - IDLER
				CONVEYOR ASSEMBLY - IDLER SHAFT
				BUSH, FLANGE 3/4 OD, x 5/8 ID
				BOLT, ADJ. - CONVEYOR IDLER
				IDLER SHAFT ADJUSTMENT BRACKET
				CONVEYOR SHAFT SUPPORT BRACKET
				CONVEYOR SPROCKET 10T W/SCREW
				SOCKET SET SCREW 1/4-28 x 3/8", SS
				IDLER SHAFT
				CONVEYOR FRAME ASSEMBLY - DRIVE
				CONVEYOR FRAME WELDMENT
				CONVEYOR ASSEMBLY - DRIVE SHAFT
				SHAFT COLLAR W/SCREW
				BUSH, FLANGE 3/4 OD x 5/8 ID
				NYLON SPACER
				CONVEYOR SHAFT SUPPORT BRACKET
				CONVEYOR SPROCKET 10T W/SCREW
				SOCKET SET SCREW 1/4-28 x 3/8", SS
				DRIVE SHAFT ADAPTER
				ROLLER CHAIN SPROCKET W/SCREW
				SOCKET SET SCREW 10-32 x 5/16" SS
				DRIVE SHAFT
				DRIVE CHAIN ASSEMBLY - 18" LONG
				MASTER LINK
				SPROCKET, DRIVE MOTOR 15T W/SCREW
				GEAR MOTOR 1/15 HP 1350:1
				BRUSHES - GEAR MOTOR
				HEX NUT 10-32
				SPLIT WASHER #10, SS
				FLAT WASHER #10, SS
				CONVEYOR CONTROL PICKUP KIT
				CONVEYOR END STOP
				CONVEYOR LEFT HAND REAR STOP
				CONVEYOR RIGHT HAND REAR STOP
				CRUMB PAN IDLER END
				CRUMB PAN DRIVE END
				PLUG, HOLE 3/4" SS
1	30290RH	31286RH	31299RH	CONVEYOR ASSEMBLY W/BELT
1	30433LH	31271LH	31304LH	CONVEYOR ASSEMBLY W/BELT
1		31268	31041	CONVEYOR BELT WIRE SS, 130"
2	33900-0032	33900-0081	33900-0035	CONVEYOR BELT SECTION WIRE SS, 1 FT
3	42400-0089	49400-0197	49400-0090	MASTER LINK KIT NOTE: MASTER LINK KIT INCLUDES ITEMS 4, 5, AND 6.
4	--	--	--	MASTER LINK - RIGHT INCLUDED IN ITEM 4
5	--	--	--	MASTER LINK - MIDDLE INCLUDED IN ITEM 4
6	--	--	--	MASTER LINK - LEFT INCLUDED IN ITEM 4
7	35900-0398	35900-0398	35900-0398	PIVOT PLATE - CONVEYOR FRAME
8	21176-0002	21176-0002	21176-0002	LOCKNUT, HEX SS 3/8-20
9	30291	31272	31301	CONVEYOR FRAME ASSEMBLY - IDLER
10	30292	31236	31233	CONVEYOR FRAME WELDMENT - IDLER
11	49400-0013	49400-0175	49400-0240	CONVEYOR ASSEMBLY - IDLER SHAFT
12	22034-0003	22034-0003	22034-0003	BUSH, FLANGE 3/4 OD, x 5/8 ID
13	35000-1008	35000-1008	35000-1008	BOLT, ADJ. - CONVEYOR IDLER
14	37000-0413	37000-0413	37000-0413	IDLER SHAFT ADJUSTMENT BRACKET
15	35900-0020	35900-0020	35900-0020	CONVEYOR SHAFT SUPPORT BRACKET
16	22229-0003	22229-0003	22229-0003	CONVEYOR SPROCKET 10T W/SCREW
17	A/R	21276-0040	21276-0040	SOCKET SET SCREW 1/4-28 x 3/8", SS
18	1	35000-1011	35900-0422	IDLER SHAFT
19	1	30298	31300	CONVEYOR FRAME ASSEMBLY - DRIVE
20	1	30299	31231	CONVEYOR FRAME WELDMENT
21	1	49400-0011	49400-0241	CONVEYOR ASSEMBLY - DRIVE SHAFT
22	1	22011-0013	22011-0013	SHAFT COLLAR W/SCREW
12	2	22034-0003	22034-0003	BUSH, FLANGE 3/4 OD x 5/8 ID
23	2	35000-1080	35000-1080	NYLON SPACER
15	2	35900-0020	35900-0020	CONVEYOR SHAFT SUPPORT BRACKET
16	A/R	22229-0003	22229-0003	CONVEYOR SPROCKET 10T W/SCREW
17	A/R	21276-0040	21276-0040	SOCKET SET SCREW 1/4-28 x 3/8", SS
24	1	35000-1013	35000-1013	DRIVE SHAFT ADAPTER
25	1	22151-0002	22151-0002	ROLLER CHAIN SPROCKET W/SCREW
26	1	21276-0038	21276-0038	SOCKET SET SCREW 10-32 x 5/16" SS
27	1	35000-1012	35000-1072	DRIVE SHAFT
28	1	49400-0050	49400-0050	DRIVE CHAIN ASSEMBLY - 18" LONG
29	1	22273-0002	22273-0002	MASTER LINK
30	1	22151-0003	22151-0003	SPROCKET, DRIVE MOTOR 15T W/SCREW
31	1	27384-0011	27384-0011	GEAR MOTOR 1/15 HP 1350:1
32	2	22450-0230	22450-0230	BRUSHES - GEAR MOTOR
33	4	21126-0007	21126-0007	HEX NUT 10-32
34	4	21426-0005	21426-0005	SPLIT WASHER #10, SS
35	4	A19682	A19682	FLAT WASHER #10, SS
36	1	27170-0263	27170-0263	CONVEYOR CONTROL PICKUP KIT
37	1	31006	30851	CONVEYOR END STOP
38	1	30830	30830	CONVEYOR LEFT HAND REAR STOP
38	1	30796	30796	CONVEYOR RIGHT HAND REAR STOP
39	2	31468	30742	CRUMB PAN IDLER END
40	2	31469	30741	CRUMB PAN DRIVE END
41	1	27413-0002	27413-0002	PLUG, HOLE 3/4" SS

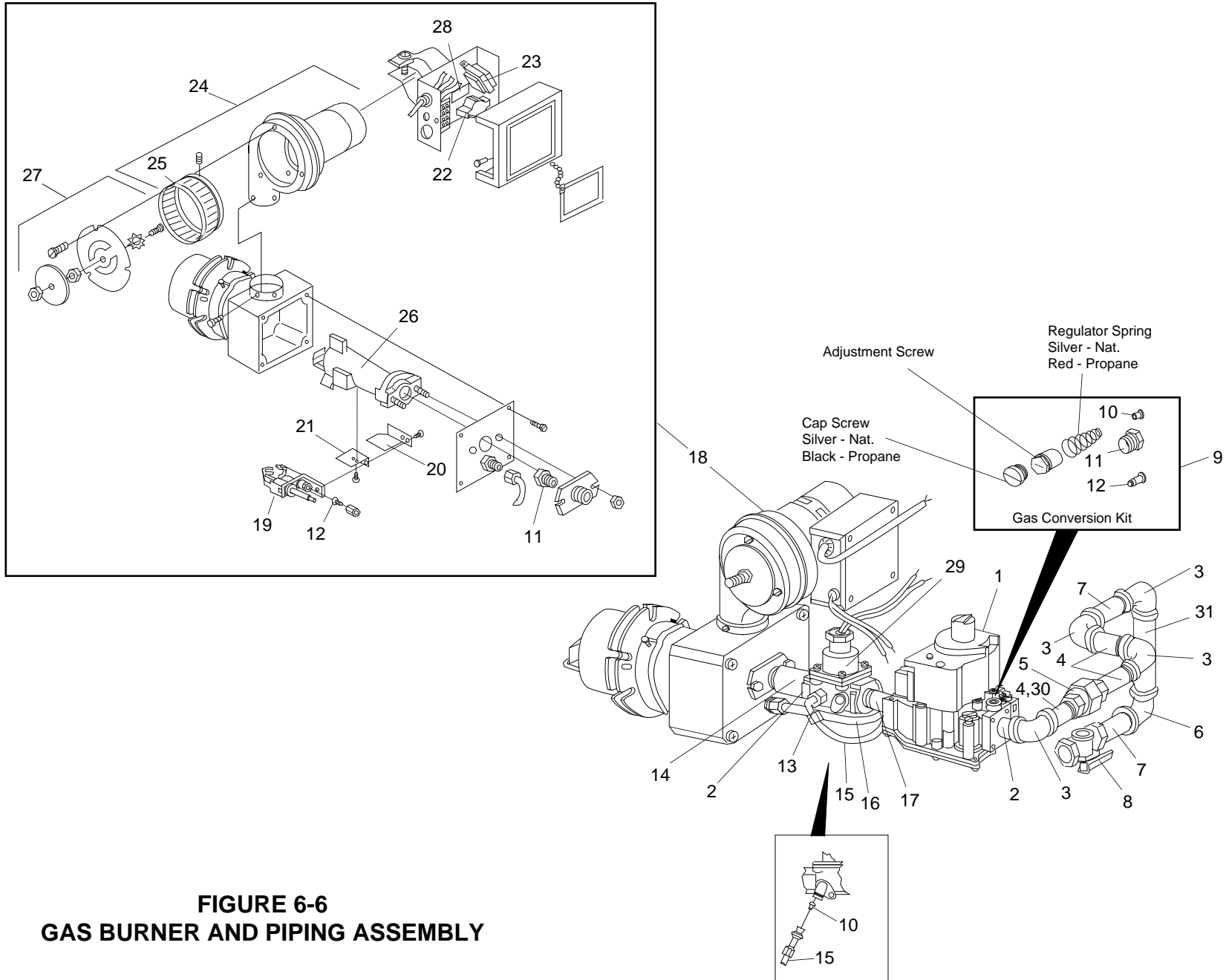

**FIGURE 6-6
GAS BURNER AND PIPING ASSEMBLY**

GAS BURNER AND PIPING ASSEMBLY

ITEM NO.	QTY.	PART NO.	DESCRIPTION
1	1	42810-0121	1/2" GAS CONTROL VALVE
2	2	23153-0004	1/2" CLOSE NIPPLE - BLK
3	2	23122-0004	1/2" ELBOW - 90°
4	2	23151-0030	1/2" x 2" NIPPLE - BLK
5	1	23051-0003	1/2" PIPE UNION
6	1	23125-0002	1/2" x 3/4" REDUCER ELBOW - 90°
7	1	23151-0001	3/4" x 2-1/2" NIPPLE - BLK
8	1	23115-0010	3/4" MANUAL GAS SHUTOFF VALVE
9	1	42810-0123	NATURAL TO PROPANE CONVERSION KIT, PS220-R68 & PS224-R68
9	1	42810-0126	PROPANE TO NATURAL CONVERSION KIT, PS220-R68 & PS224-R68
9	1	42810-0122	NATURAL TO PROPANE CONVERSION KIT, PS200-R68
9	1	42810-0125	PROPANE TO NATURAL CONVERSION KIT, PS200-R68
10	1	22174-0006	ORIFICE #53 DRILL LOW FLAME - NATURAL
10	1	22174-0009	ORIFICE #62 DRILL LOW FLAME - PROPANE
11	1	22176-0016	ORIFICE, MAIN BURNER - NATURAL (0.182"), PS220-R68 & PS224-R68
11	1	22176-0017	ORIFICE, MAIN BURNER - PROPANE (0.113"), PS220-R68 & PS224-R68
11	1	22176-0006	ORIFICE, MAIN BURNER - NATURAL (0.196"), PS200-R68
11	1	22176-0007	ORIFICE, MAIN BURNER - PROPANE (0.129"), PS200-R68
12	1	22174-0011	ORIFICE, PILOT - NATURAL (.024")
12	1	22174-0010	ORIFICE, PILOT - PROPANE (.014")
13	2	23126-0016	ELBOW - MALE 1/4" TUBE x 1/8" NPT
14	1	23015-0004	1/2" COUPLING NPT
15	1	35900-0098	1/4" TUBING - ALUM 8"
16	1	35900-0099	1/4" TUBING - ALUM 6-1/2"
17	1	23151-0030	1/2" x 2" NIPPLE - BLK
18	1	27361-0015	GAS BURNER ASSEMBLY
19	1	27363-0002	PILOT ASSEMBLY W/IGNITOR
20	1	27170-0204	PILOT SHIELD
21	1	27170-0264	PILOT IGNITOR BRACKET
22	1	27170-0016	MOTOR RELAY
23	1	27170-0017	TRANSFORMER 120/240V
24	1	27170-0011	BLOWER MOTOR ASSEMBLY
25	1		BLOWER WHEEL, INCLUDED IN ITEM #24
26	1	27170-0223	VENTURI W/TARGET
27	1	42810-0087	AIR SHUTTER KIT
28	1	27030-0005	FUSE HOLDER WITH FUSE (1 AGC)
29	1	28091-0017	1/2" SOLENOID VALVE
30	1	23151-0032	1/2" x 3" NIPPLE - BLK, R.H. DRIVE ONLY
31	1	31315	1/2" x 31" PIPE, UPPER OVEN ONLY
31	1	31238	1/2" x 4" PIPE, LOWER OVEN ONLY

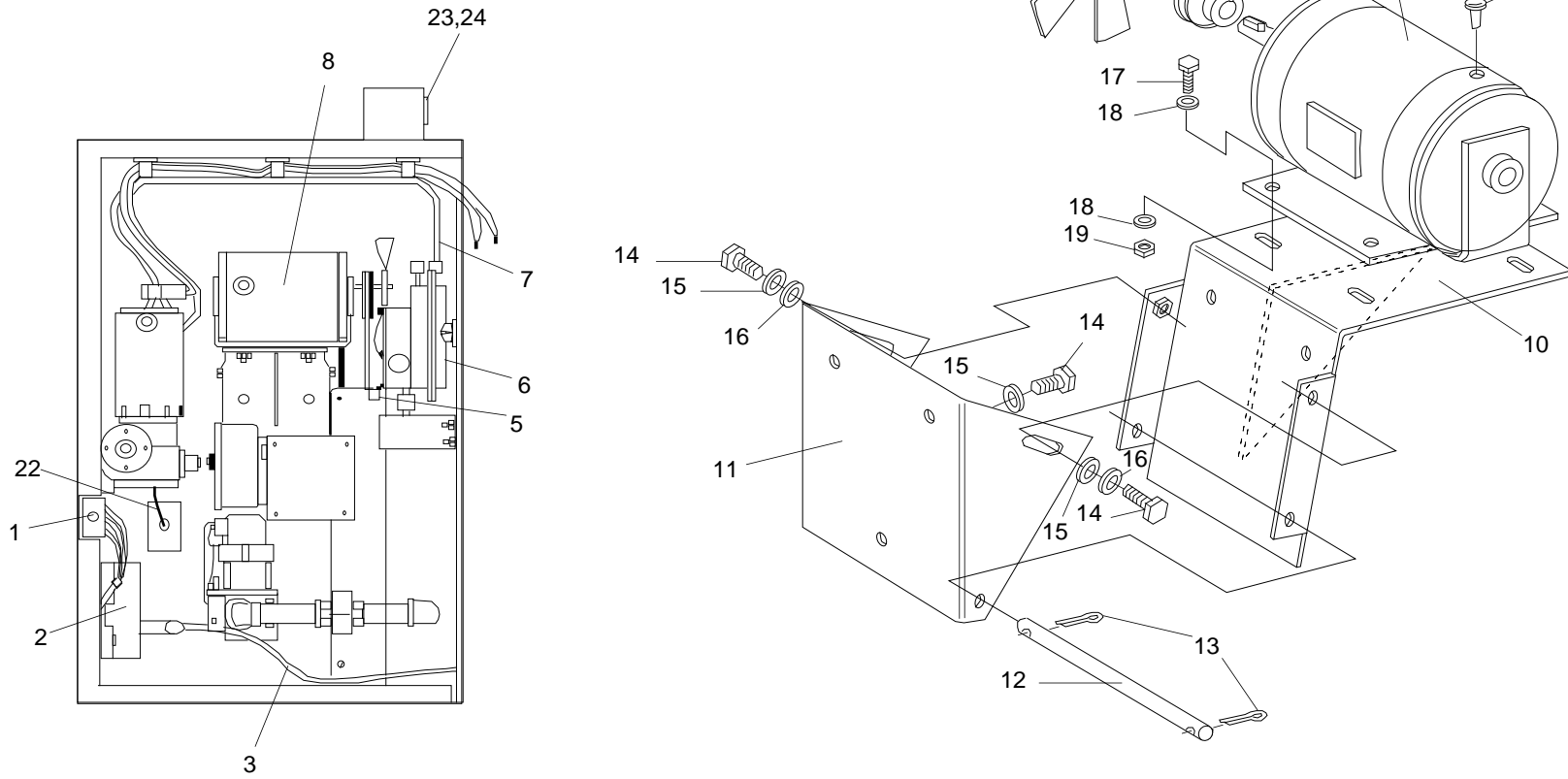

FIGURE 6-7
MACHINERY COMPARTMENT

MACHINERY COMPARTMENT

ITEM NO.	QTY.	PART NO.	MODEL	DESCRIPTION
1	1	28021-0047	GAS & ELECTRIC	SAFETY INTERLOCK SWITCH
2	1	42810-0114	GAS	IGNITION CONTROL MODULE
3	1	27159-0019	GAS	IGNITION/SENSOR WIRE
5	1	28021-0061	GAS & ELECTRIC	SAFETY, MOMENTARY, 10A NO 2 POLE
6	1	28023-0005	GAS & ELECTRIC	AIR SWITCH
7	1	35900-0105	GAS & ELECTRIC	TUBING 1/4" x 45-1/8"
8	1	27381-0066	GAS & ELECTRIC	MOTOR 1/3 HP 200-240V 1PH
9	1	27221-0015	GAS & ELECTRIC	SNAP - IN BUSHING - NYLON, BLACK
10	1	37900-0005	GAS & ELECTRIC	MOUNTING BRACKET - MOTOR
11	1	35900-0076	GAS 7 ELECTRIC	SUPPORT BRACKET - MOTOR
12	1	35900-0075	GAS & ELECTRIC	ROD - MOTOR BRACKET
13	2	21611-0007	GAS & ELECTRIC	COTTER PIN 1/8" X 1/2"
14	3	220373	GAS & ELECTRIC	BOLT 3/8"-16 x 1 SS HX
15	3	21426-0001	GAS & ELECTRIC	3/8" SPLIT WASHER
16	2	21416-0001	GAS & ELECTRIC	3/8" FLAT WASHER SS
17	4	A3896	GAS & ELECTRIC	HEX HD SCREW 5/16-18 x 1" SS
18	8	21416-0002	GAS & ELECTRIC	FLAT WASHER 5/16"
19	4	21126-0004	GAS & ELECTRIC	HEX NUT SS 5/16-18
20	1	22230-0073	GAS & ELECTRIC	PULLEY, 5/8 BORE AK32
20	1	22230-0074	GAS & ELECTRIC	PULLEY, 50Hz - EXPORT ONLY AK.41
21	1	27399-0007	GAS & ELECTRIC	COOLING FAN - 5/8" BORE
22	1	48019-0027	GAS & ELECTRIC	THERMOCOUPLE TYPE J - GAS OVEN
23	1	32342	GAS & ELECTRIC	MACH. COMPARTMENT RECEPTACLE ASSY AC
24	1	32343	GAS & ELECTRIC	MACH. COMPARTMENT RECEPTACLE ASSY DC

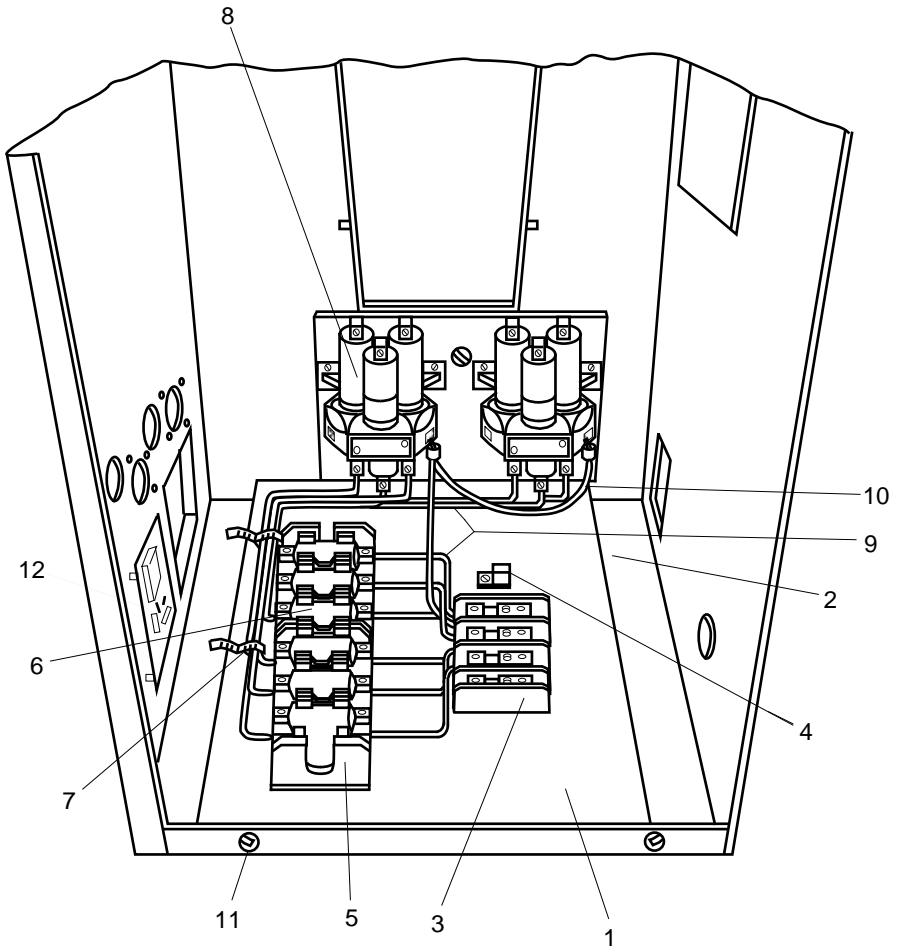

FIGURE 6-8
ELECTRIC OVEN ELECTRIC PANEL

ELECTRIC OVEN ELECTRIC PANEL

ITEM NO.	QTY.	PART NO.	DESCRIPTION
1	1	37900-0097	ELECTRIC PANEL W/O COMPONENTS
2	1	37900-0096	BRACKET - ELECTRIC PANEL
3	2	27480-0001	POWER DISTRIBUTION BLOCK - 2 POLE
4	1	15028707	GROUND LUG
5	2	27021-0016	FUSE BLOCK - 3 POLE, 60 AMP, 600V, CLASS T
6	6	28150-0130	FUSE - 50 AMP, 600V, CLASS T
7	A/R	27276-0003	CABLE CLAMP
8	A/R	28041-0015	MERCURY CONTACTOR 3 POLE
8	A/R	27170-0247	CONTACTOR TUBE KIT W/CLIP FOR P/N 28041-0015
8	1	42810-0090	CONTACTOR COIL KIT (INCLUDES COIL & 3 RETAINER CLIPS)
9	A/R	27152-0025	WIRE STRAND 10 GA 105° C. BL.
10	A/R	27152-0053	WIRE STRAND 18 GA 105° C. BL.
11	3	21256-0008	10-32-3/8 TRUSS HD. SS
12	1	28071-0025	HI/LO LIMIT BOARD

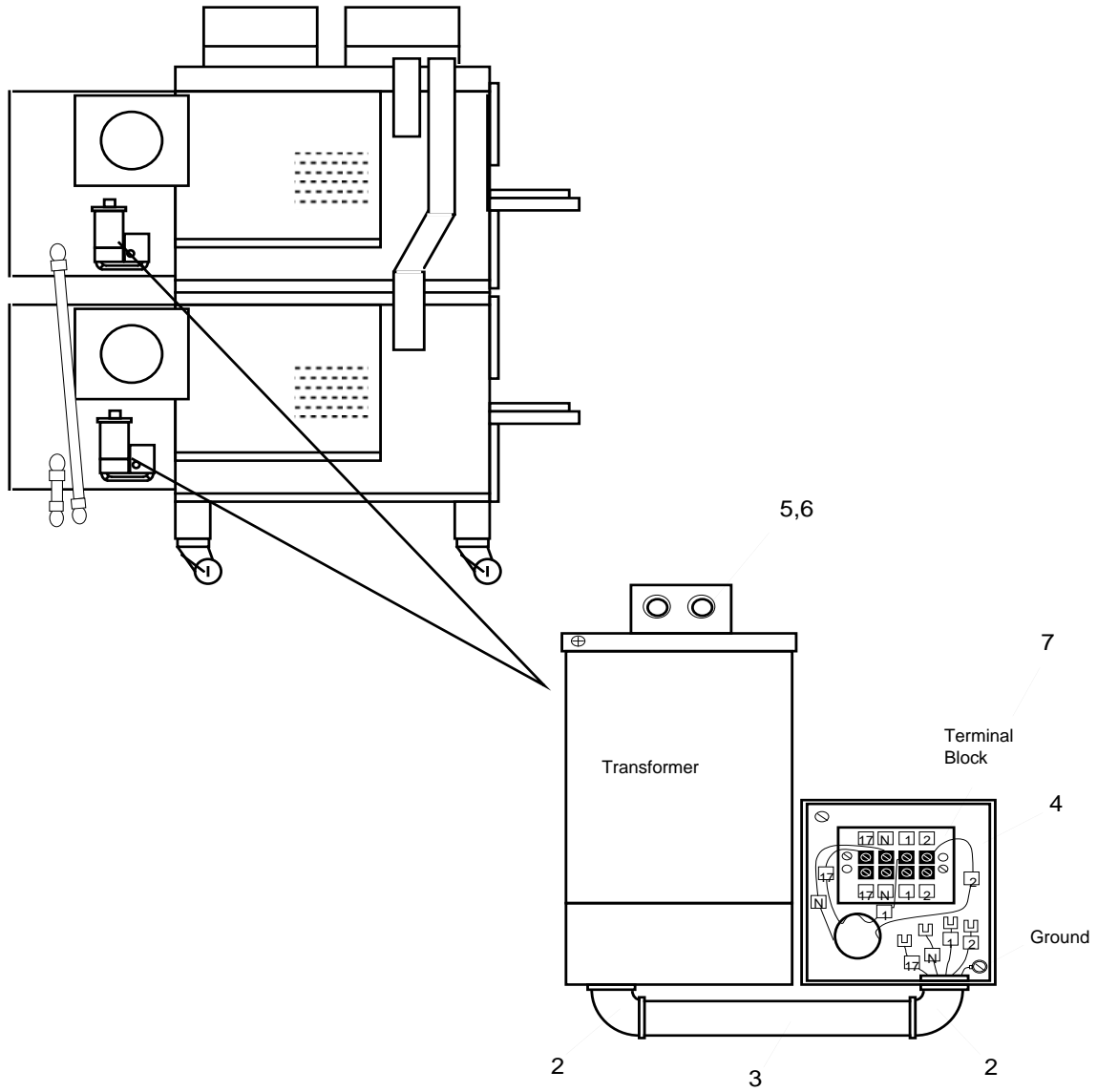

FIGURE 6-9
JUNCTION BOX AND EXPORT TRANSFORMER

JUNCTION BOX AND EXPORT TRANSFORMER

ITEM NO.	QTY.	PART NO.	DESCRIPTION
1	1	28082-0010	TRANSFORMER .75 KVA 240-480V EXPORT ONLY
1	1	28082-0011	TRANSFORMER 1.0 KVA 190-380V EXPORT ONLY
2	2	27083-0008	BOX CONNECTOR 1/2" x 50°
3	1	35900-0147	CONDUIT 1/2" x 6"
4	1	27292-0009	JUNCTION BOX 4" x 4"
5	2	A3333	BOLT 1/4"-20 x 3/4" SS
6	2	21426-0002	SPLIT WASHER 1/4" SS
7	1	27011-0010	TERMINAL BLOCK - 30 AMP 600V, 4 POLE
7	1	27011-0011	TERMINAL BLOCK - 30 AMP 600V, 8 POLE
Not Shown		42810-0086	TRANSFORMER KIT FOR 110V SUPPLY
Not Shown		28082-0016	2.0 KVA - USED WITH TRANSFORMER KIT # 42810-0086 110 - 220V.

NOTES

SECTION 7
ELECTRICAL SCHEMATICS

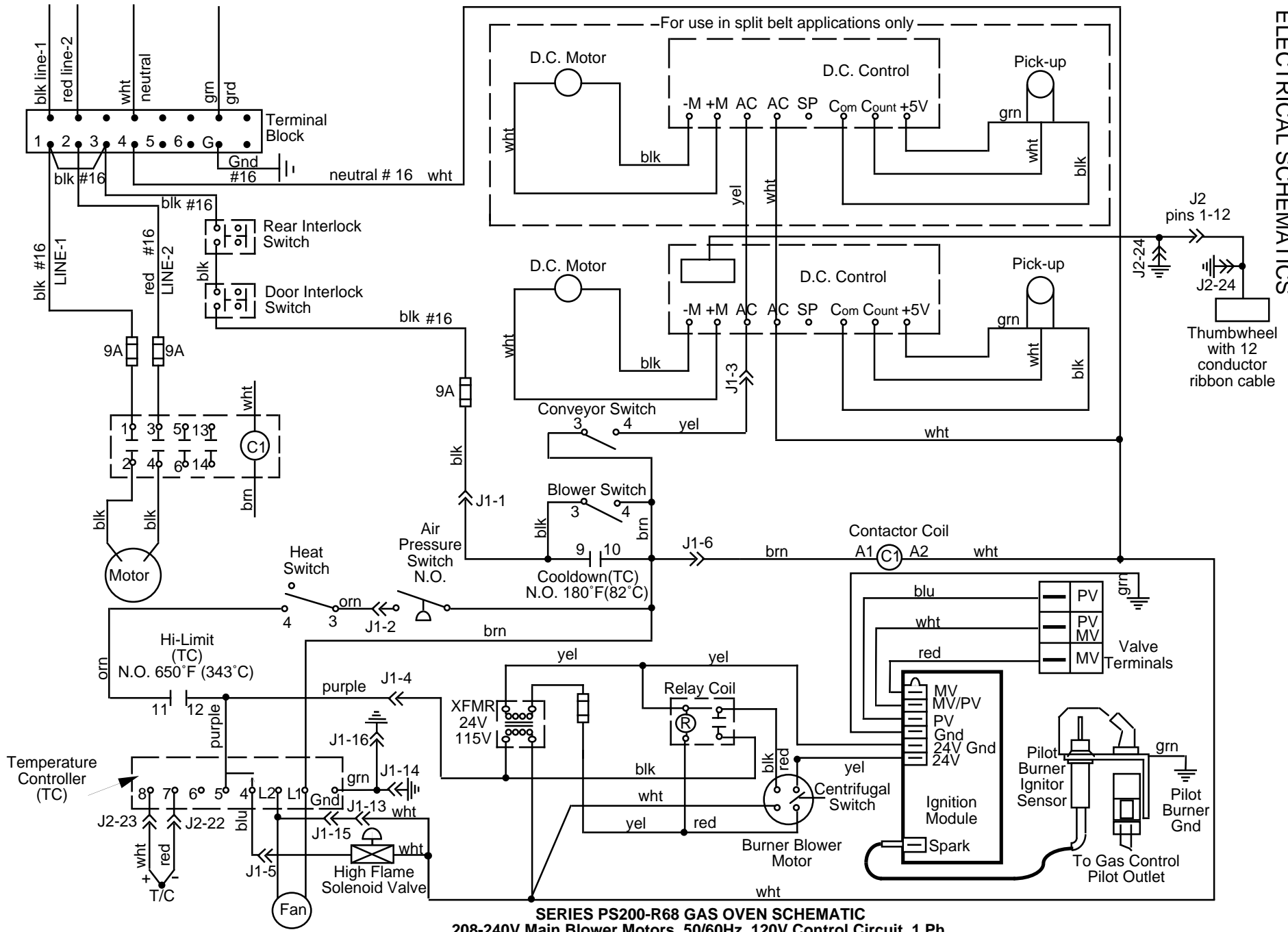

SERIES PS200-R68 GAS OVEN SCHEMATIC
 208-240V Main Blower Motors, 50/60Hz, 120V Control Circuit, 1 Ph,
 4.1 Amp Draw, 3 Pole, 4 Wire (2 hot, 1 neut, 1 grd)

08

J2
24 pin cable,
Both connectors
female

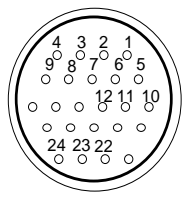

- Pin #'s 1-12
Thumbwheel Ribbon Cable
starting with Pin #1 - blue
- Pin #22 Red, Thermocouple
- Pin #23 Wht, Thermocouple
- Pin #24 Ground

J1

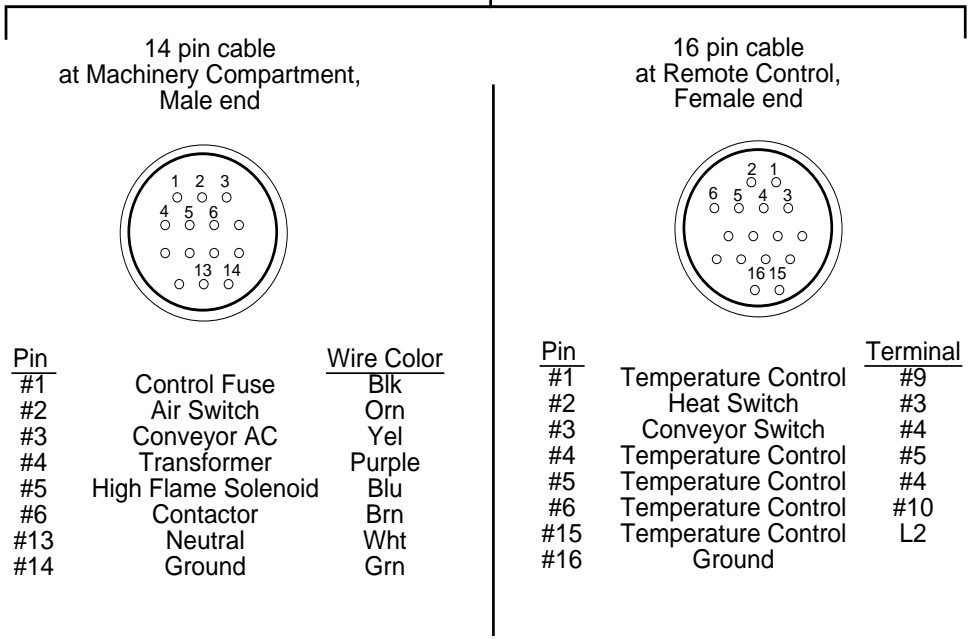

14 pin cable
at Machinery Compartment,
Male end

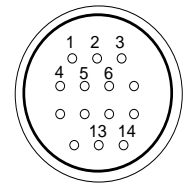

<u>Pin</u>		<u>Wire Color</u>
#1	Control Fuse	Blk
#2	Air Switch	Orn
#3	Conveyor AC	Yel
#4	Transformer	Purple
#5	High Flame Solenoid	Blu
#6	Contactar	Brn
#13	Neutral	Wht
#14	Ground	Gm

16 pin cable
at Remote Control,
Female end

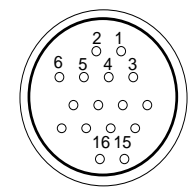

<u>Pin</u>		<u>Terminal</u>
#1	Temperature Control	#9
#2	Heat Switch	#3
#3	Conveyor Switch	#4
#4	Temperature Control	#5
#5	Temperature Control	#4
#6	Temperature Control	#10
#15	Temperature Control	L2
#16	Ground	



**Middleby
Marshall**

Middleby Marshall Inc. • 1400 Toastmaster Drive • Elgin, IL 60120 • (708) 741-3300 • FAX (708)741-4406

***National Service Cooperative 1-800-298-1862
Middleby Corporation Service Hotline 1-800-238-8444***