

PS200VL, PS220VL,  
& PS224VL

# ***PS200VL/220VL/224VL Gas Ovens***

## ***Models:***

- PS200VL
- PS220VL
- PS224VL

# ***PARTS MANUAL***

***for domestic and standard export ovens***

© 2000 Middleby Marshall, Inc.



**Middleby  
Marshall®** is a registered trademark of Middleby Marshall, Inc. All rights reserved.

Middleby Cooking Systems Group • 1400 Toastmaster Drive • Elgin, IL 60120 • (847)741-3300 • FAX (847)741-4406

# TABLE OF CONTENTS

<i>Section</i>	<i>Page</i>
I. Key Spare Parts Kit .....	3
II. Installation Kit .....	4
III. Oven Base/Legs/Casters Kit .....	5
IV. Oven Panels, Windows, and Legs .....	6
V. Cool Front .....	8
VI. Blower, Shrouds and Vents .....	10
VII. Machinery Compartment .....	12
VIII. Control Panel .....	14
IX. External Transformer - Export Ovens Only .....	16
X. Gas Burner System .....	18
XI. Conveyor Assembly - Single Conveyor .....	20
XII. Conveyor Assembly - Split Belt Conveyor .....	22

**NOTE:** Throughout this Parts Manual, the following abbreviations are used:

*A/R = Quantity As Required*

*N/A = Does Not Apply*

PS200VL, PS220VL,  
& PS224VL

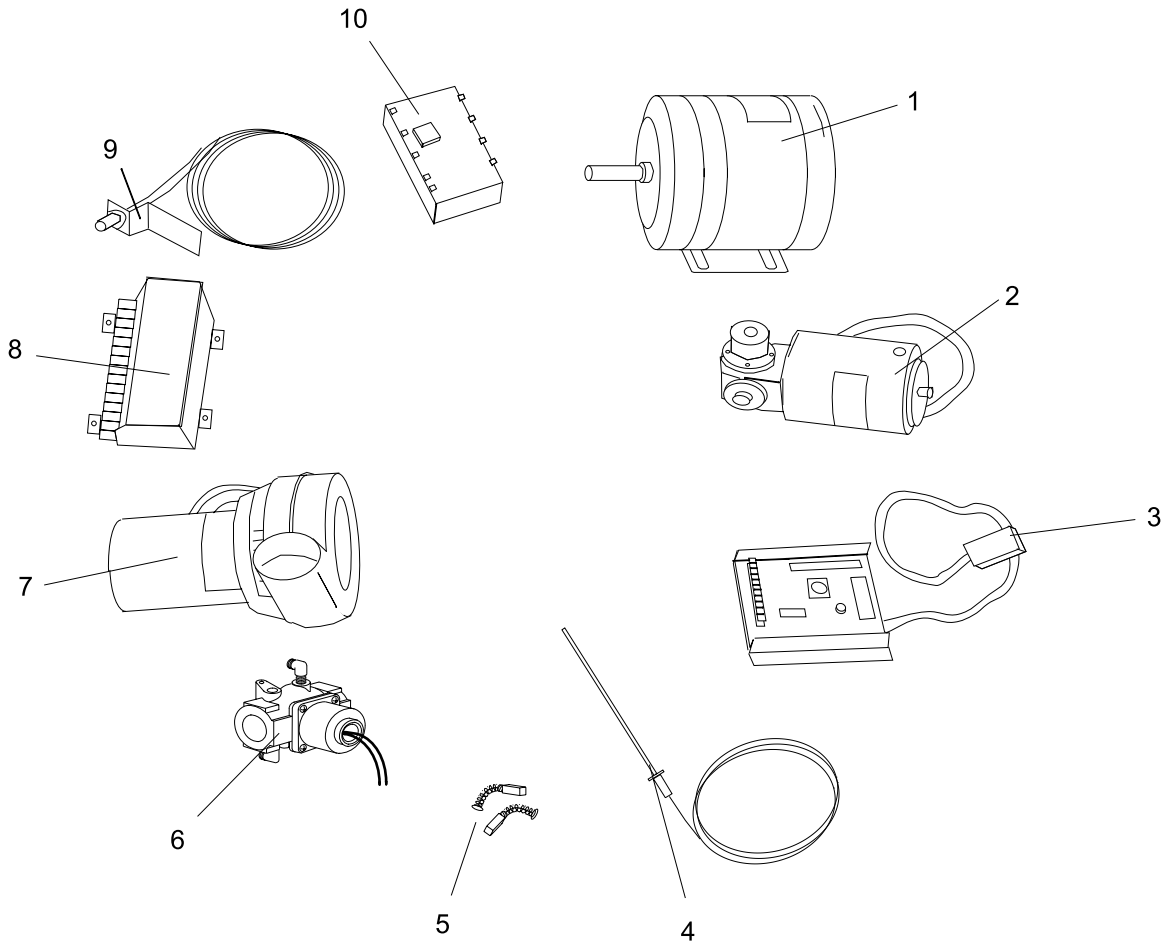

PS200VL, PS220VL,  
& PS224VL

## I. KEY SPARE PARTS KIT

ITEM	PART NO.	QTY.	DESCRIPTION
1	27381-0066	1	BLOWER/FAN MOTOR
2	27384-0011	1	CONVEYOR DRIVE MOTOR
3	42810-0133	1	CONVEYOR SPEED CONTROLLER
4	33985	1	THERMOCOUPLE
5	22450-0230	2	CONVEYOR DRIVE MOTOR BRUSHES
6	28091-0017	1	SOLENOID VALVE
7	27170-0011	1	BURNER MOTOR/BLOWER ASSEMBLY
8	42810-0114	1	IGNITION MODULE
9	27170-0263	1	CONVEYOR CONTROL PICKUP
10	34982	1	HIGH LIMIT CONTROL

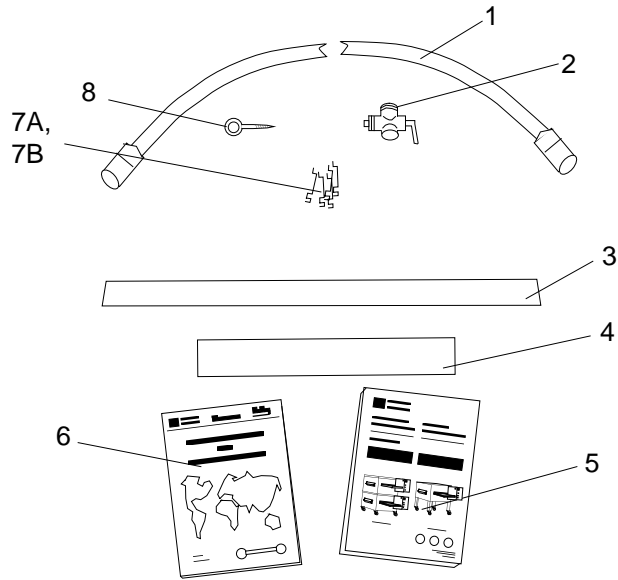

## II. INSTALLATION KIT

ITEM	PART NO.			QTY.		DESCRIPTION
	PS200VL	PS220VL	PS224VL	Sgl oven	Dbf oven	
1	22361-0001	22361-0001	22361-0001	1	2	GAS HOSE, FLEXIBLE
2	23115-0010	23115-0010	23115-0010	1	2	GAS SHUTOFF VALVE, 3/4"
3	35000-1103	35900-0370	35900-0442	1	2	CONVEYOR END STOP
4	35900-0148	35900-0376	35900-0148	1	2	CONVEYOR REAR STOP
5	36019	36019	36019	1	2	OWNER'S OPERATING MANUAL
6	1002040	1002040	1002040	1	2	SERVICE AGENCY DIRECTORY
7A	42400-0089	49400-0197	42400-0090	1	2	MASTER LINKS KIT - SINGLE BELT OVENS
7B	42400-0089	36596	42400-0589	2	4	MASTER LINKS KIT - SPLIT BELT OVENS
8	21392-0005	21392-0005	21392-0005	1	2	SCREW EYE, LAG, 3/4" ID x 2-1/2"

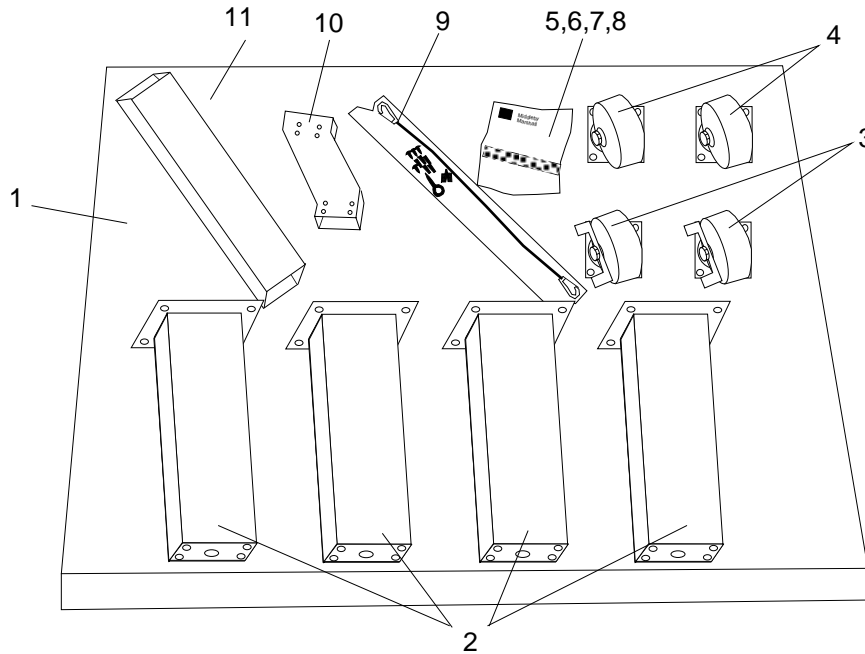

PS200VL, PS220VL,  
& PS224VL

### III. OVEN BASE/LEGS/CASTERS KIT

ITEM	PART NO.			QTY.		DESCRIPTION
	PS200VL	PS220VL	PS224VL	Sgl oven	Dbl oven	
1	30427	30806	30807	1	1	BASE PAD, PAINTED
2	30426	30426	30426	4	--	LEG, 15" (381mm), PAINTED - SINGLE OVENS
ONLY						
3	22290-0009	22290-0009	22290-0009	2	2	SWIVEL CASTER w/LOCKING BRAKE
4	22290-0010	22290-0010	22290-0010	2	2	SWIVEL CASTER
5	220373	220373	220373	32	16	3/8-16 x 1" HEX BOLT
6	21416-0001	21416-0001	21416-0001	32	16	3/8" FLAT WASHER
7	21422-0001	21422-0001	21422-0001	32	16	3/8" SPLIT WASHER
8	21256-0008	21256-0008	21256-0008	4	4	10-32 x 3/8" RH SCREWS FOR TOP
9	22450-0228	22450-0228	22450-0228	1	1	RESTRAINT CABLE ASSEMBLY
10	37900-0041	37900-0041	37900-0041	--	1	FLUE OFFSET - DOUBLE OVENS ONLY
11	37900-0042	37900-0042	37900-0042	--	1	FLUE EXTENSION - DOUBLE OVENS ONLY
--	35900-0011	35900-0347	35900-0413	1	1	OVEN TOP

PS200VL, PS220VL,  
& PS224VL

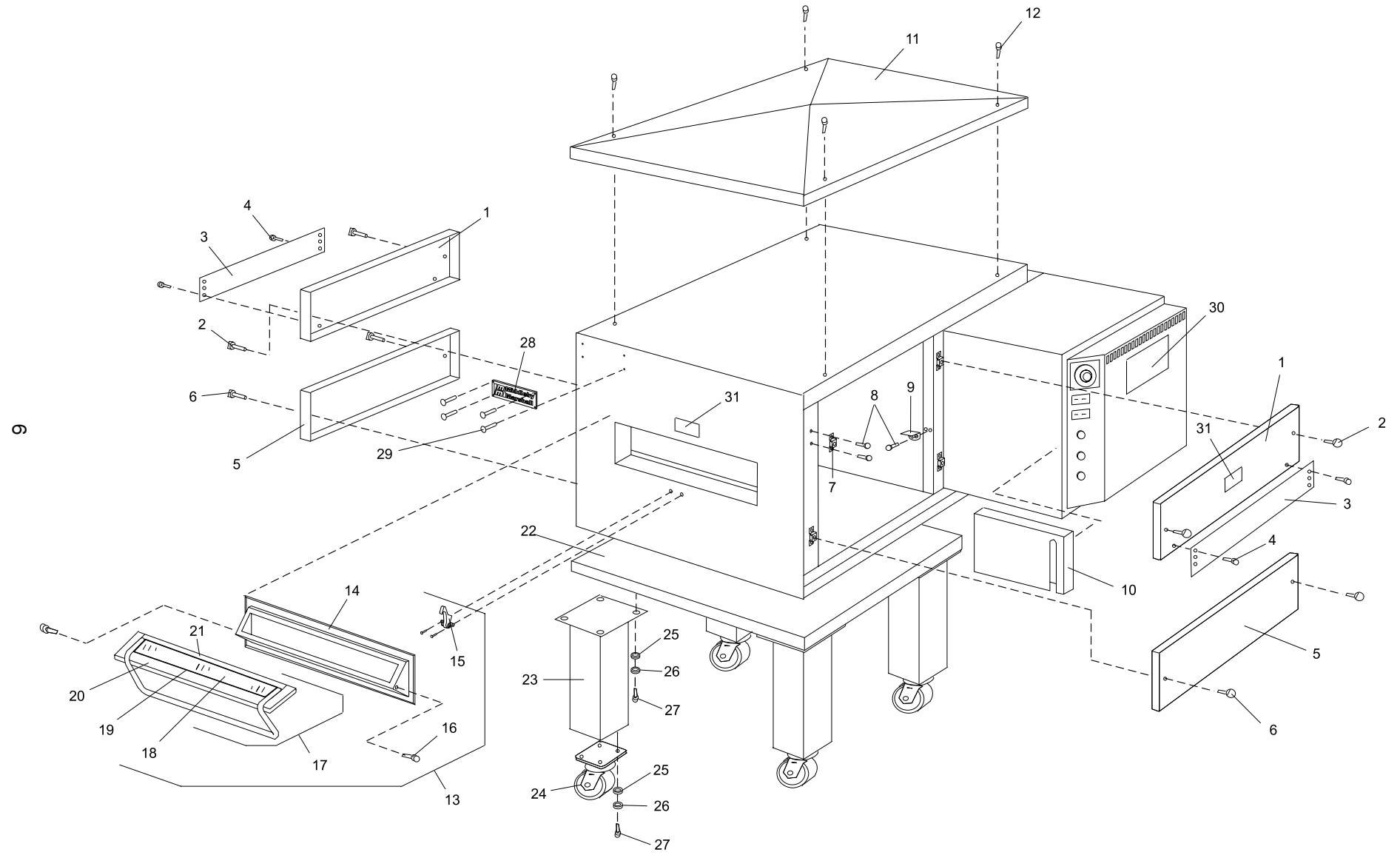

## IV. OVEN PANELS, WINDOW AND LEGS

ITEM	QTY.	PART NO.			DESCRIPTION
		PS200VL	PS220VL	PS224VL	
1	2	34991	38394	35377	UPPER END PLUG
2	2	21296-0003	21296-0003	21296-0003	WING SCREW, 1/4-20 x 1/2" SS
3	2	35900-0052	35900-0355	35900-0431	EYEBROW, ADJUSTABLE - <i>OPTIONAL</i>
4	4	2000346	2000346	2000346	SCREW, SLT 1/4-20 x 1/2"
5	2	35900-0041	35900-0323	35900-0417	END PLUG, LOWER
6	2	21296-0003	21296-0003	21296-0003	WING SCREW, 1/4-20 x 1/2" SS
7	8	49400-0056	49400-0056	49400-0056	MOUNTING BRACKET - END PLUG
8	A/R	21292-0001	21292-0001	21292-0001	SCREW, 10-16 x 3/4" HEX HD
9	4	35900-0043	35900-0043	35900-0043	SHELF BRACKET - UPPER END PLUG
10	1	30743	30743	30743	CHAIN GUARD
11	1	35900-0011	35900-0347	35900-0413	OVENTOP
12	4	21256-0025	21256-0025	21256-0025	SCREW, 10-32 x 3/8" SS
13	1	49400-0120	49400-0120	49400-0120	WINDOWASSEMBLY
14	1	37900-0103	37900-0103	37900-0103	WINDOW MOUNTING FRAME
15	1	42400-0087	42400-0087	42400-0087	WINDOW LATCH ASSEMBLY
16	2	34121-0003	34121-0003	34121-0003	SCREW, THUMB PIVOT
17	1	30285	30285	30285	GLASS DOOR ASSEMBLY
18	1	22140-0017	22140-0017	22140-0017	TEMPERED GLASS
19	11 oz.	17130-0006	17130-0006	17130-0006	SEALANT, SILICONE RUBBER
20	1	30287	30287	30287	GLASS DOOR FRAME WELDMENT
21	1	30286	30286	30286	GLASS TOP FRAME
22	1	30427	30806	30807	BASE PAD, PAINTED
23	4	30426	30426	30426	LEGS, PAINTED - <i>SINGLE OVENS ONLY</i>
24	2	22290-0009	22290-0009	22290-0009	SWIVEL CASTER w/LOCKING BRAKE
24	2	22290-0010	22290-0010	22290-0010	SWIVEL CASTER
25	A/R	21416-0001	21416-0001	21416-0001	WASHER, 3/8" FLAT
26	A/R	21422-0001	21422-0001	21422-0001	WASHER, 3/8" SPLIT
27	A/R	220373	220373	220373	BOLT, 3/8-16 x 1" HEX HD
28	1	22500-0021	22500-0021	22500-0021	PLATE, NAME, "MIDDLEBY MARSHALL"
29	4	220311	220311	220311	SCREW, 10-32 x 3/8"
30	1	38136	38136	38136	LABEL, OPERATING INSTRUCTIONS, PS200VL GAS (ENGLISH)
31	1	22500-0041	22500-0041	22500-0041	LABEL, "CAUTION - HOT SURFACE" (ENGLISH)

**PS200VL, PS220VL,  
& PS224VL**

**COOL FRONT-  
WITH WINDOW OPENING**

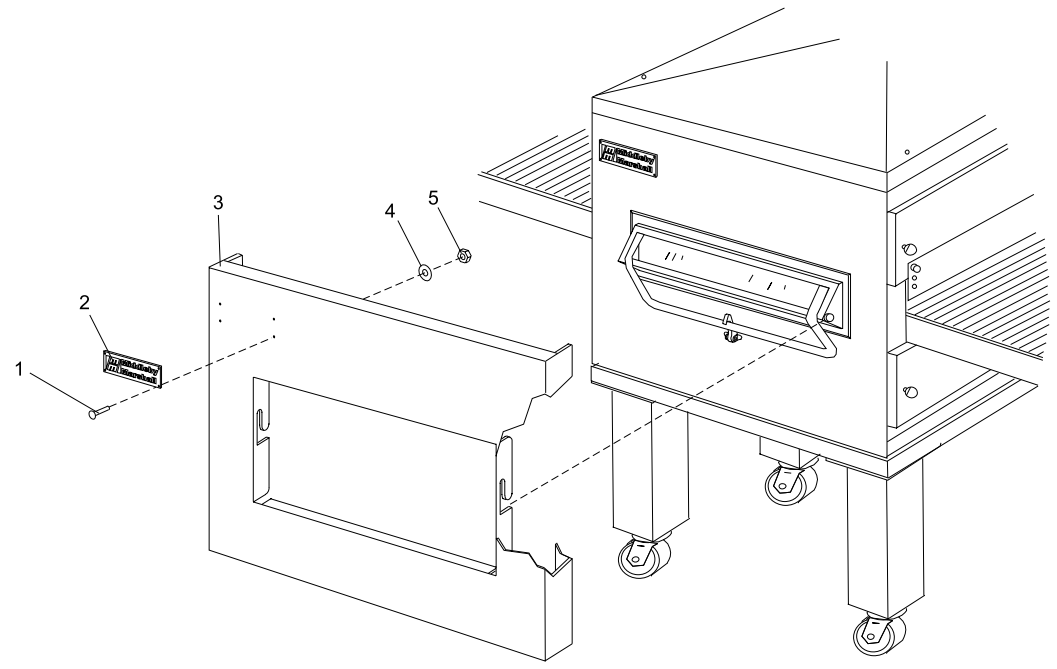

**COOL FRONT-  
WITHOUT WINDOW OPENING**

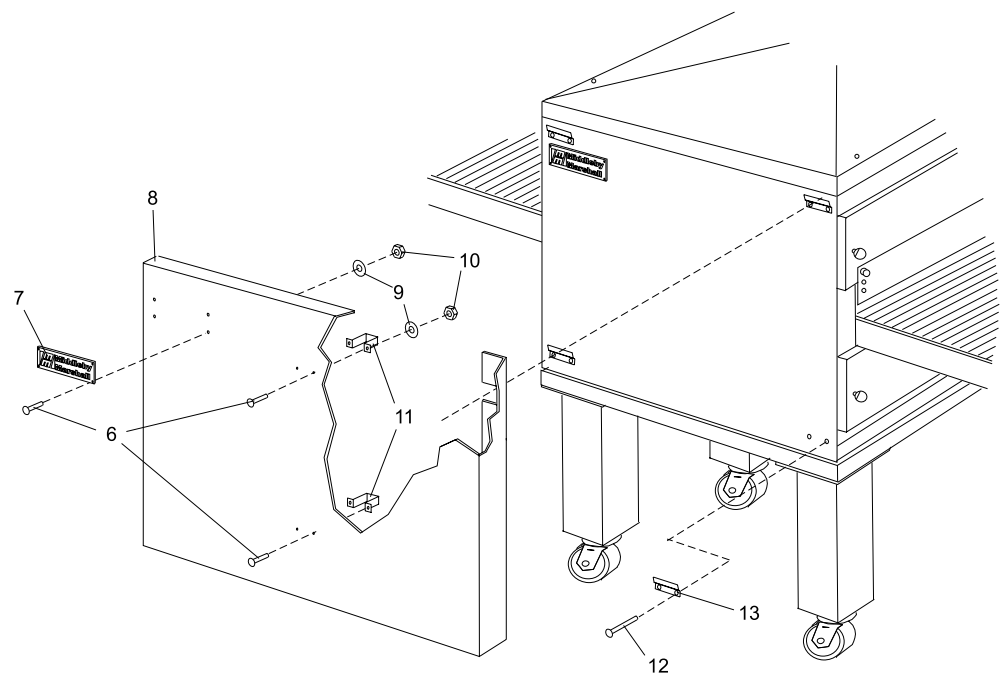

## V. COOL FRONT

### COOL FRONT WITH WINDOW OPENING

<i>ITEM</i>	<i>QTY.</i>	<i>PART NO.</i>	<i>DESCRIPTION</i>
-	1	37329	ASSEMBLY, PS200VL COOL FRONT/WITH WINDOW OPENING
1	4	220311	SCREW, 10-32 x 3/8"
2	1	22500-0021	PLATE, NAME, "MIDDLEBY MARSHALL"
3	1	37336	PANEL, COOL FRONT/WITH WINDOW OPENING
4	4	21442-0005	LOCK WASHER
5	4	F707A8803	HEX NUT, 10-32, NP

### COOL FRONT WITHOUT WINDOW OPENING

<i>ITEM</i>	<i>QTY.</i>	<i>PART NO.</i>	<i>DESCRIPTION</i>
-	1	35944	ASSEMBLY, PS200VL COOL FRONT/NO WINDOW OPENING
6	8	220311	SCREW, 10-32 x 3/8"
7	1	22500-0021	PLATE, NAME, "MIDDLEBY MARSHALL"
8	1	35926	PANEL, COOL FRONT/NO WINDOW OPENING
9	8	21442-0005	LOCK WASHER
10	8	F707A8803	HEX NUT, 10-32, NP
11	2	35470	BRACKET, CENTER SUPPORT, FOR COOL FRONT PANEL
12	8	21292-0001	SCREW, 10-16 x 3/4"
13	4	35900-0259	HANGER, COOL FRONT PANEL

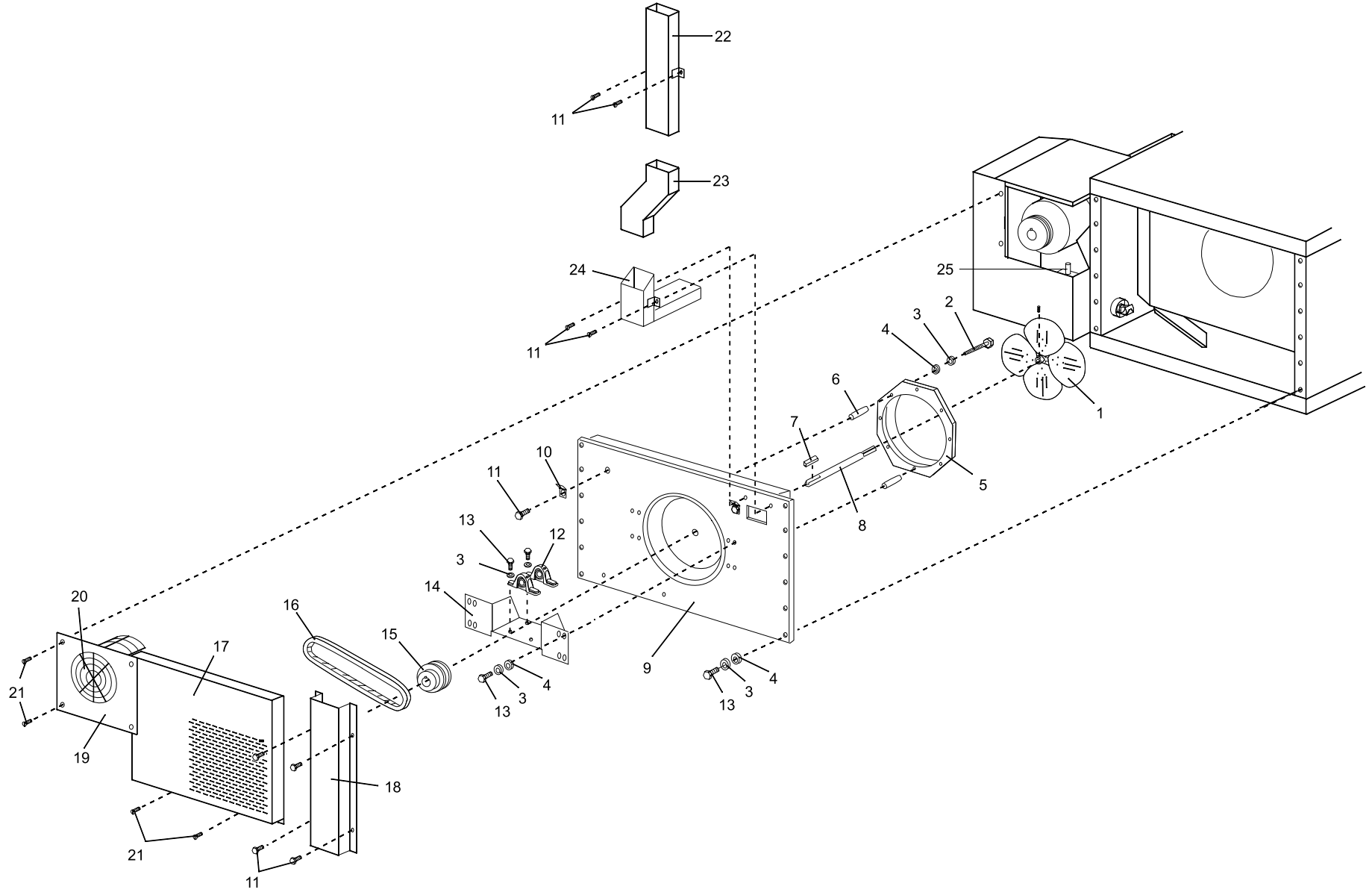

## VI. BLOWER, SHROUDS, AND VENTS

ITEM	QTY.	PART NO.	DESCRIPTION
1	1	27399-0003	FAN, 16" (406MM) DIA.
2	A/R	21326-0002	BOLT, 3/8"-16 x 5-1/2" HEX HD SS
3	A/R	21422-0001	WASHER, 3/8" SPLIT SS
4	A/R	21416-0001	WASHER, 3/8" FLAT SS
5	1	22450-0217	RING SHROUD
6	8	35900-0108	STAND-OFF TUBE
7	1	21651-0010	KEY, PULLEY
8	1	35900-0232	SHAFT, FAN DRIVE
9	1	37900-0088	BACK WALL
10	2	35900-0259	HANGER BRACKET, REAR SHROUD
11	A/R	21292-0001	SCREW, 10-16 x 3/4" HEX HD
12	2	22072-0025	BEARING, PILLOW BLOCK, 5/8"
13	24	21216-0001	BOLT, 3/8"-16 x 1" HEX HD SS
14	1	37900-0101	BRACKET, FAN DRIVE SUPPORT
15	1	22230-0073	PULLEY, 5/8" BORE AK32
16	1	22181-0034	FAN BELT
17	1	37900-0058	REAR SHROUD
18	1	35900-0200	VENT SHROUD - <i>OPTIONAL</i>
19	1	37900-0067	COVER, REAR CONTROL PANEL
20	1	27470-0035	GUARD, COOLING FAN
21	4	21256-0009	SCREW, 10-32 x 5/8" TRUSS CAP
22	1	37900-0042	FLUE VENT EXTENSION - <i>DOUBLE OVENS ONLY</i>
23	1	37900-0041	FLUE VENT CROSSOVER - <i>DOUBLE OVENS ONLY</i>
24	1	49400-0029	FLUE VENT
25	1	28021-0061	SWITCH, REAR SHROUD SAFETY - <i>SEE PP. 16-17</i>

PS200VL, PS220VL,  
& PS224VL

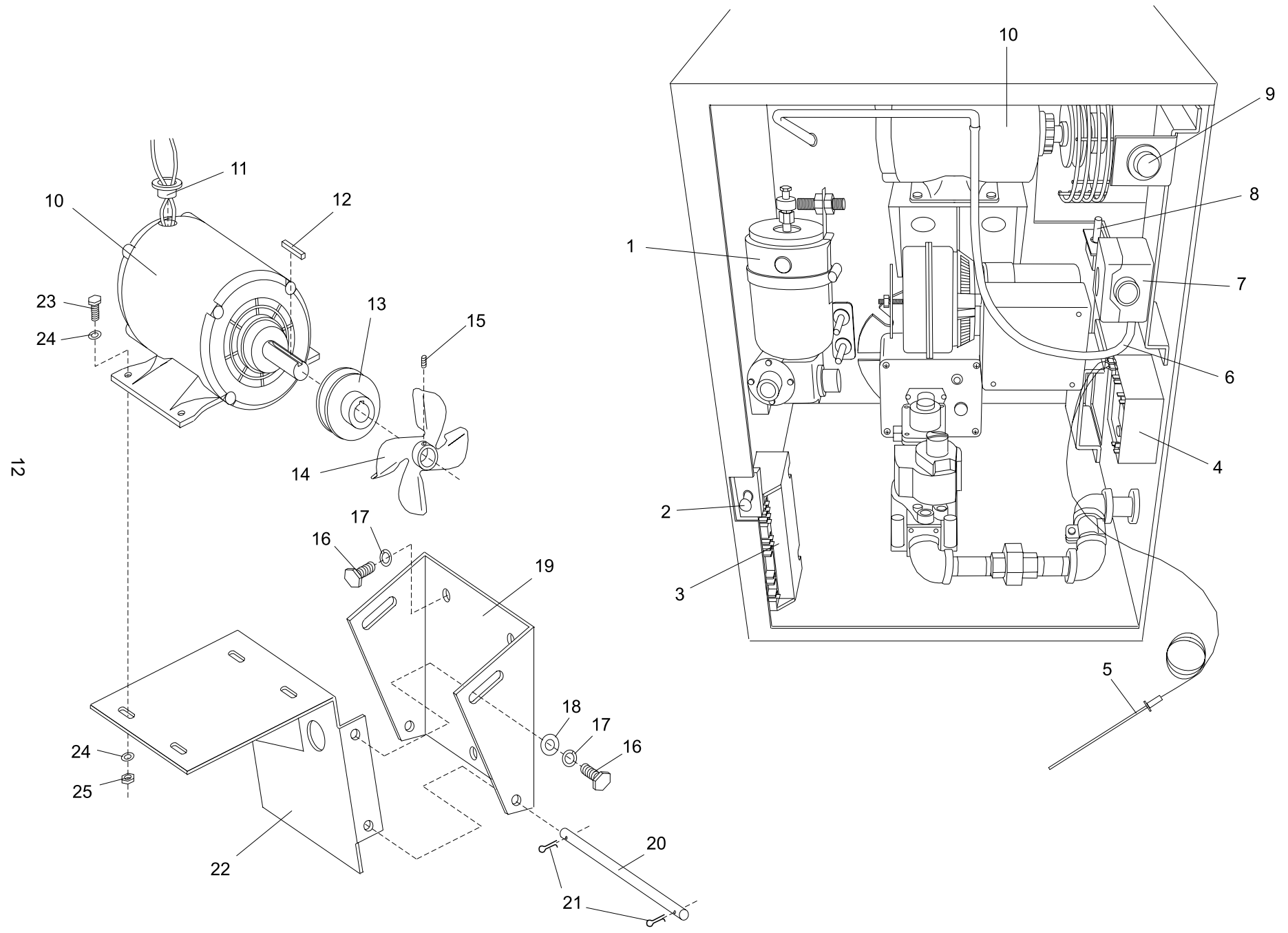

## VII. MACHINERY COMPARTMENT

ITEM	QTY.	PART NO.	DESCRIPTION
1	A/R	27384-0011	MOTOR, CONVEYOR GEAR - <i>SEE PP. 22-25</i>
2	1	28021-0047	SWITCH, DOOR SAFETY
3	1	42810-0114	KIT, IGNITION MODULE
4	1	34982	CONTROL, HIGH LIMIT
5	1	33985	KIT, THERMOCOUPLE
6	A/R	35900-0105	AIR TUBING, SILICONE, 1/4" (6.4mm) DIA.
7	1	35624	KIT, AIR PRESSURE SWITCH
8	1	28021-0061	SWITCH, REAR SHROUD SAFETY
9	1	30693	PUSHBUTTON, HIGH LIMIT RESET
10	1	27381-0066	MOTOR, BLOWER - 1/3 HP, 200-240V, 1 PH
11	1	27221-0015	BUSHING, WIRING, SNAP-IN
12	1	21651-0010	KEY, BLOWER PULLEY
13	1	22230-0073	PULLEY, 5/8" BORE AK32
14	1	27399-0004	FAN, COOLING, 5/8" BORE
15	1	-	SET SCREW, COOLING FAN - <i>INC. W/ITEM 14</i>
16	5	21216-0001	BOLT, HEX, 3/8"-16 x 1" SS
17	5	21422-0001	WASHER, SPLIT, 3/8"
18	2	21416-0001	WASHER, FLAT, 3/8" SS
19	1	35900-0076	BRACKET, MOTOR SUPPORT, ADJUSTABLE
20	1	35900-0075	ROD, PIVOT, MOTOR BRACKET
21	2	21671-0007	COTTER PIN
22	1	37900-0005	BRACKET, MOTOR MOUNTING
23	4	21416-0013	BOLT, HEX, 5/16"-18 x 1" SS
24	8	21412-0005	WASHER, FLAT, 5/16"
25	4	21126-0004	NUT, HEX, 5/16"-18 SS

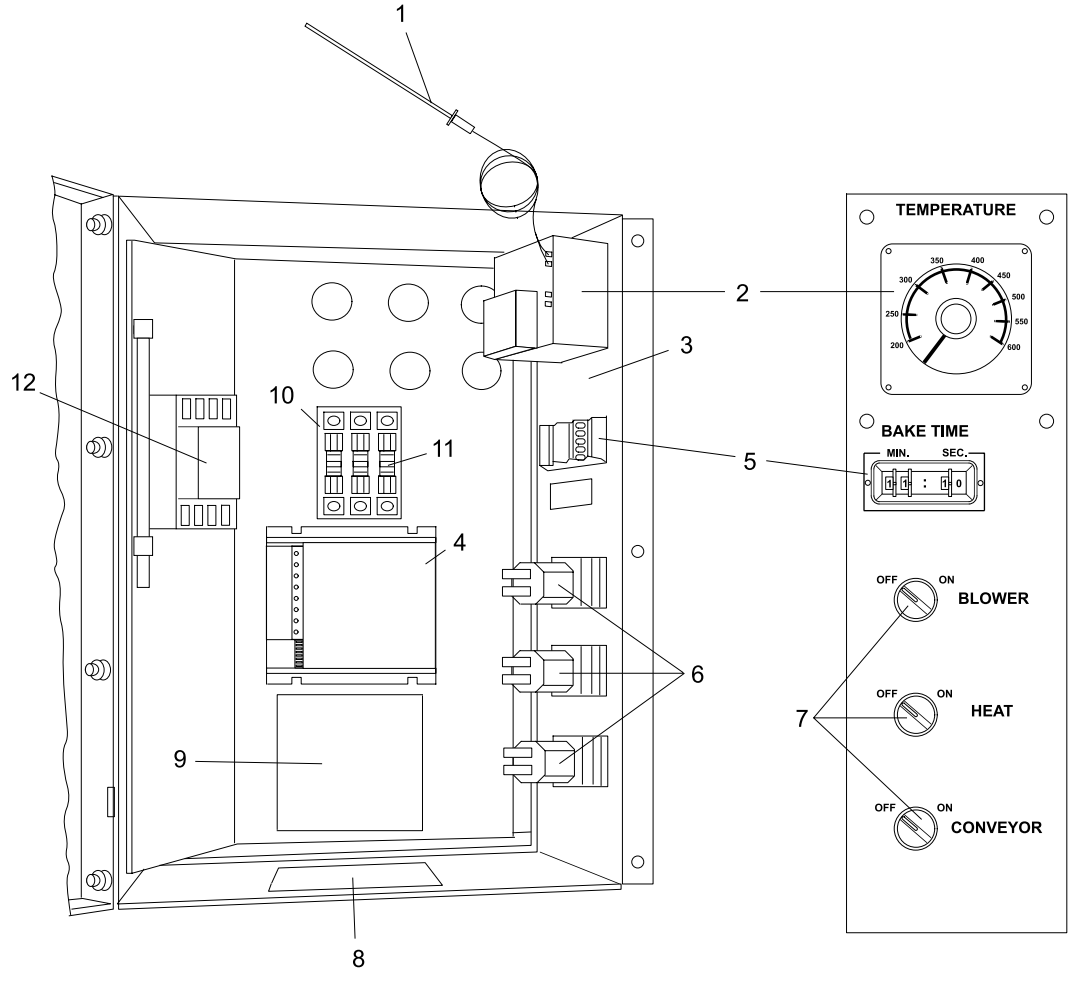

## VIII. CONTROL PANEL

<i>ITEM</i>	<i>QTY.</i>	<i>PART NO.</i>	<i>DESCRIPTION</i>
1	1	33985	KIT, THERMOCOUPLE
2	1	34983	TEMPERATURE CONTROLLER
3	1	37900-0001	DOOR PANEL, MACHINERY COMPARTMENT
4	1	42810-0133	KIT, CONVEYOR SPEED CONTROLLER
5	1	42810-0118	THUMBWHEEL - INC. W/ITEM 4
6	3	27060-0012	CONTACT BLOCK WITH BASE
7	3	28021-0062	SWITCH KNOB, BLUE
8	1	-	LABEL, AIR FINGER ARRANGEMENT
9	1	35946	LABEL, PS200VL WIRING DIAGRAM
10	1	27021-0011	FUSE BLOCK
11	3	28154-0003	FUSE, 9A
12	1	28041-0008	CONTACTOR

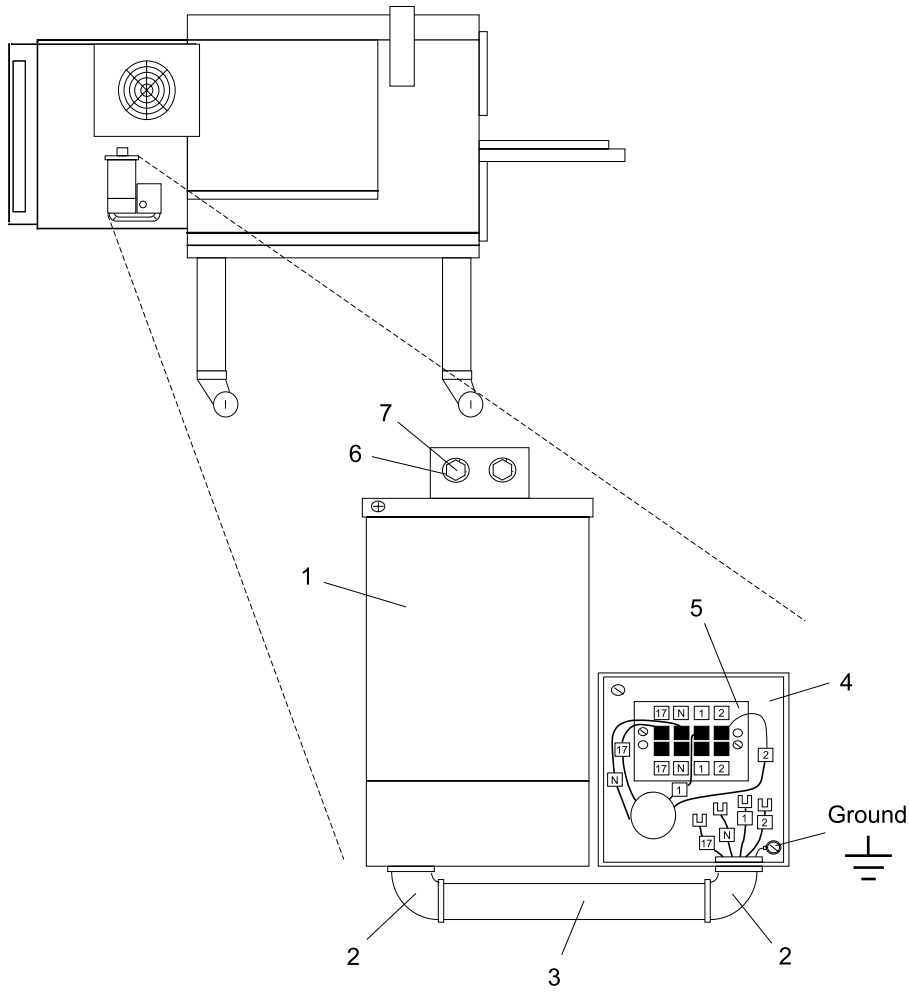

## IX. EXTERNAL TRANSFORMER (EXPORT OVENS ONLY)

<i>ITEM</i>	<i>QTY.</i>	<i>PART NO.</i>	<i>DESCRIPTION</i>
1	1	28082-0010	TRANSFORMER, 0.75 KVA, 240-480V PRI.
1	1	28082-0011	TRANSFORMER, 1.0 KVA, 190-380V PRI.
2	2	27083-0008	BOX CONNECTOR, 1/2" x 50°
3	1	35900-0147	CONDUIT, 1/2" x 6"
4	1	27292-0009	JUNCTION BOX, 4" x 4"
5	1	27011-0011	TERMINAL BLOCK - 600V, 30A, 8 POLE
6	2	21421-0006	WASHER, SPLIT, 1/4" SS
7	2	21211-0004	BOLT, 1/4"-20 x 3/4" SS

**PS200VL, PS220VL,  
& PS224VL**

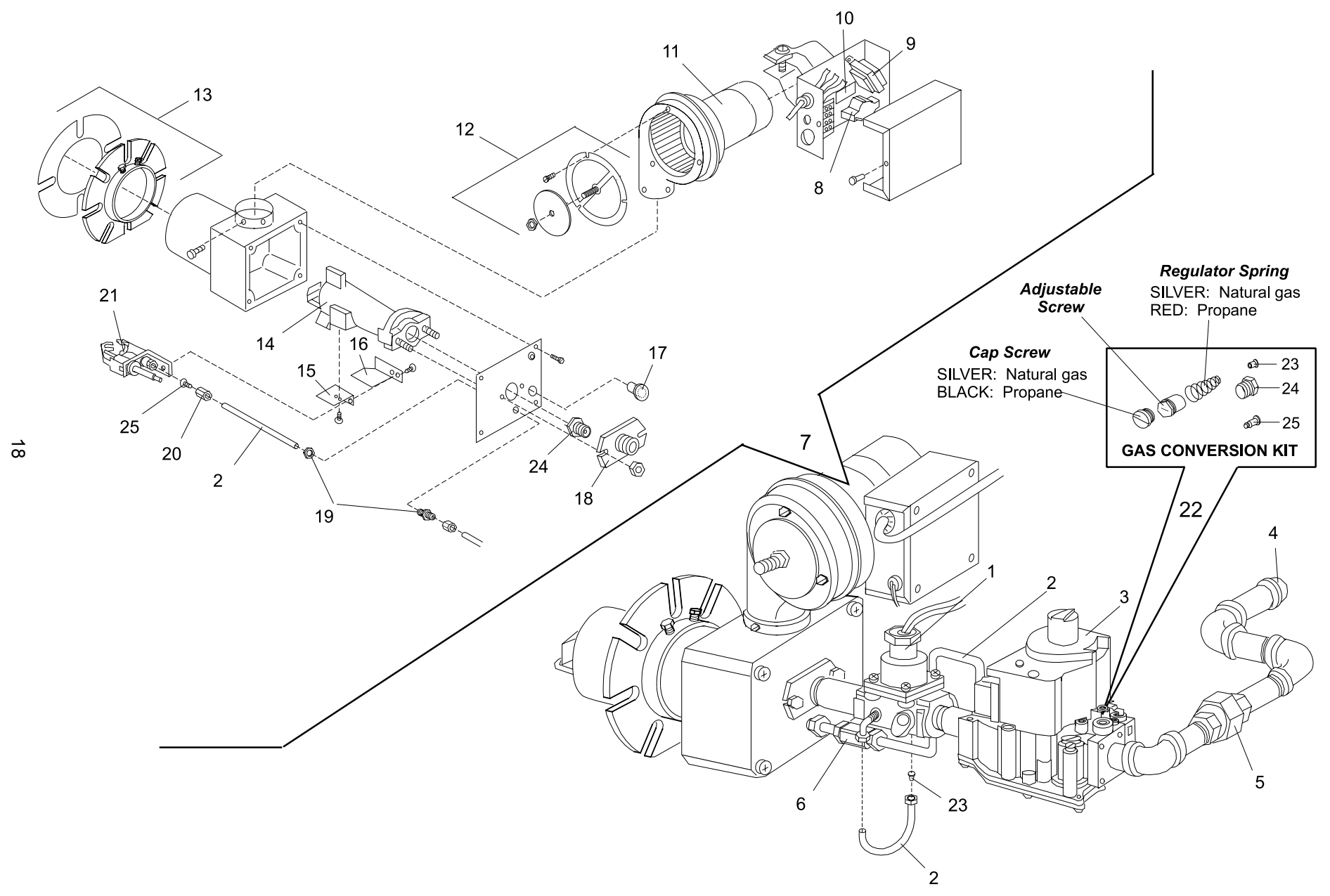

18

## X. GAS BURNER SYSTEM

ITEM	QTY.	PART NO.	DESCRIPTION
1	1	28091-0017	SOLENOID VALVE
2	A/R	15125-0002	TUBING, ALUMINUM, 1/4" DIA, 1 FT.
3	1	42810-0121	GAS CONTROL VALVE, 1/2"
4	1	22564-0011	CAP PLUG
5	1	23051-0003	UNION, 1/2"
6	1	30185	KIT, PILOT PRESSURE TAP (PILOT TEE)
7	1	27361-0018	ASSEMBLY, GAS BURNER
8	1	27170-0016	MOTOR RELAY
9	1	27170-0017	TRANSFORMER, 120/240V
10	1	27030-0005	FUSE HOLDER
11	1	27170-0011	MOTOR, BURNER BLOWER
12	1	42810-0087	KIT, EXTERNAL AIR SHUTTER
13	1	36562	KIT, BURNER MOUNTING RING
14	1	27170-0223	VENTURI ASSEMBLY
15	1	27170-0264	BRACKET, PILOT IGNITOR
16	1	27170-0204	SHIELD, PILOT
17	1	38280	WINDOW PLUG
18	1	38279	MAIN ORIFICE HOLDER/GAS INLET CONNECTOR
19	1	23052-0007	FITTING, PILOT BULKHEAD
20	1	38284	FITTING, PILOT TUBING
21	1	42810-0117	KIT, PILOT IGNITOR ASSEMBLY
22	--	42810-0122	KIT, GAS CONVERSION, NATURAL TO PROPANE, PS200
22	--	42810-0123	KIT, GAS CONVERSION, NATURAL TO PROPANE, PS220/PS224
22	--	42810-0125	KIT, GAS CONVERSION, PROPANE TO NATURAL, PS200
22	--	42810-0126	KIT, GAS CONVERSION, PROPANE TO NATURAL, PS220/PS224
23	1	22174-0006	ORIFICE, LOW FLAME #53 - NATURAL
23	1	22174-0009	ORIFICE, LOW FLAME #62 - PROPANE
24	1	22176-0010	ORIFICE, MAIN, 0.204" - NATURAL, PS200
24	1	22176-0016	ORIFICE, MAIN, 0.185" - NATURAL, PS220/PS224
24	1	49810-0009	KIT, ORIFICE CONVERSION, JAPAN - INC. P/N 22176-0008, LABEL AND INSTRUCTIONS
24	1	22176-0008	ORIFICE, MAIN, #12 DRILL - NATURAL, JAPAN
24	1	22176-0007	ORIFICE, MAIN, 0.1285" - PROPANE, PS200
24	1	22176-0017	ORIFICE, MAIN, 0.113" - PROPANE, PS220/PS224
25	1	22174-0011	ORIFICE, PILOT, 0.024" - NATURAL
25	1	22174-0010	ORIFICE, PILOT, 0.014" - PROPANE

PS200VL, PS220VL,  
& PS224VL

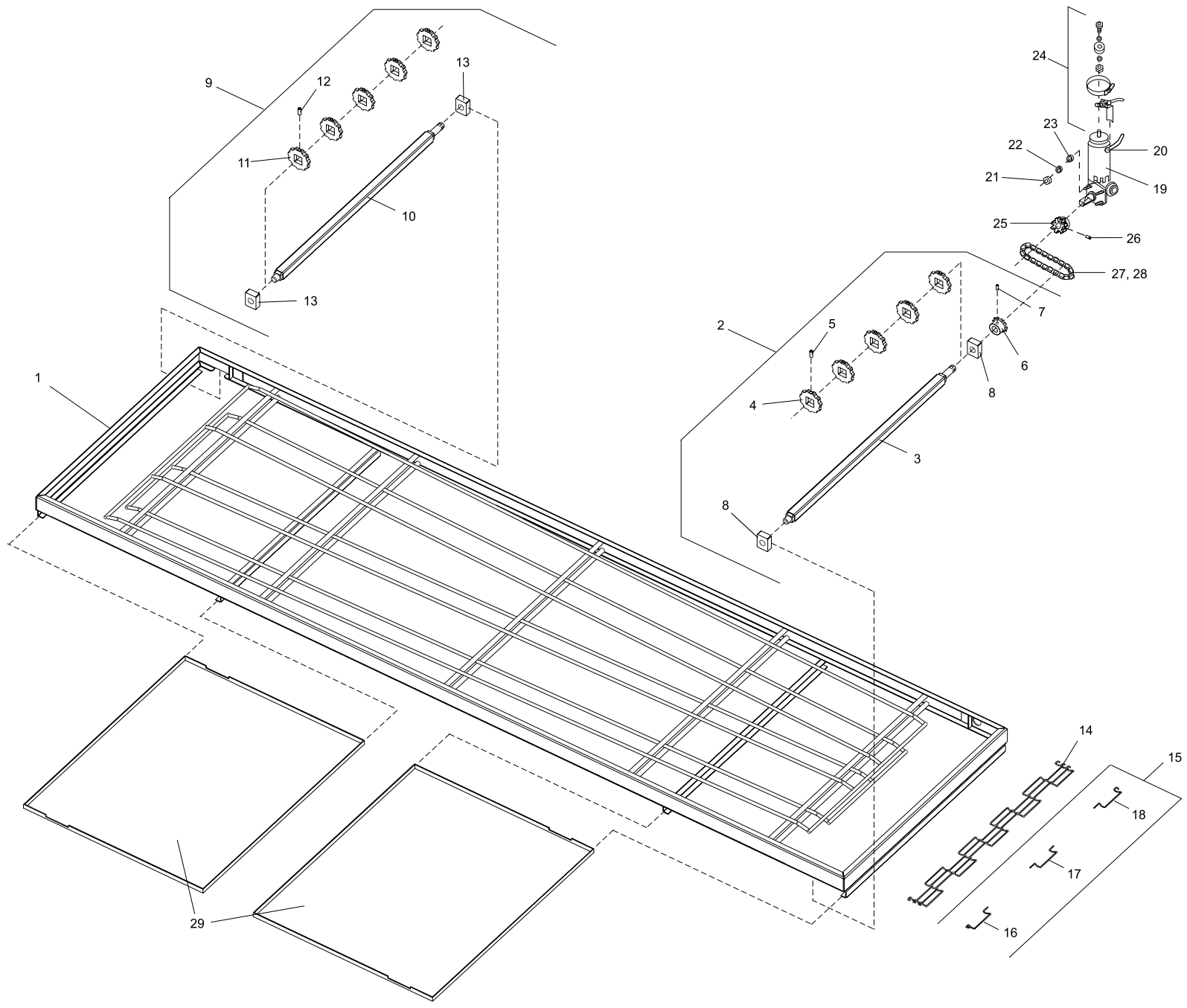

## XI. CONVEYOR ASSEMBLY - SINGLE BELT OVENS

	PS200VL		PS220VL		PS224VL		
ITEM	QTY.	P/N	QTY.	P/N	QTY.	P/N	DESCRIPTION
-	1	34996	1	37668	1	35266	ASSEMBLY, CONVEYOR
1	1	34881	1	37648	1	35272	ASSEMBLY, CONVEYOR FRAME
2	1	-	1	37665	1	-	ASSEMBLY, DRIVE SHAFT
3	1	34890	1	37651	1	35270	DRIVE SHAFT
4	6	34886	5	34886	4	34886	SPROCKET, CONVEYOR
5	6	-	5	-	4	-	SOCKET SET SCREW, CONVEYOR, #10-32 x 7/16" - INC. W/ITEM 4
6	1	35409	1	35409	1	35409	SPROCKET, DRIVE SHAFT
7	1	21265-00017	1	21265-00017	1	21265-00017	SET SCREW, DRIVE SHAFT SPROCKET, 1/4-20 x 1/4" - INC. W/ITEM 6
8	2	34871	2	34871	2	34871	BUSHING, CONVEYOR
9	1	-	1	37667	1	-	ASSEMBLY, IDLER SHAFT
10	1	34889	1	37652	1	35269	IDLER SHAFT
11	6	34886	5	34886	4	34886	SPROCKET, CONVEYOR
21 12	6	-	5	-	4	-	SET SCREW, CONVEYOR, #10-32 x 7/16" - INC. W/ITEM 11
13	2	34871	2	34871	2	34871	BUSHING, CONVEYOR
14	1	22450-0225	1	22450-0252	1	22450-0287	CONVEYOR BELT, 146" (3708mm)
15	1	42400-0089	1	49400-0197	1	42400-0090	CONVEYOR MASTER LINKS KIT
16	-	-	-	-	-	-	MASTER LINK, LEFT - INC. W/ITEM 15
17	-	-	-	-	-	-	MASTER LINKS, CENTER - INC. W/ITEM 15
18	-	-	-	-	-	-	MASTER LINK, RIGHT - INC. W/ITEM 15
19	1	27384-0011	1	27384-0011	1	27384-0011	MOTOR, CONVEYOR GEAR
20	2	22450-0230	2	22450-0230	2	22450-0230	BRUSHES, CONVEYOR GEAR MOTOR - INC. W/ITEM 19
21	4	21122-0004	4	21122-0004	4	21122-0004	NUT, 10-32 HEX HD
22	4	21421-0003	4	21421-0003	4	21421-0003	WASHER, #10 SPLIT
23	4	21421-0011	4	21421-0011	4	21421-0011	WASHER, #10 FLAT
24	1	27170-0263	1	27170-0263	1	27170-0263	CONVEYOR CONTROL PICKUP KIT
25	1	22151-0003	1	22151-0003	1	22151-0003	SPROCKET, CONVEYOR GEAR MOTOR (15T)
26	1	-	1	-	1	-	SET SCREW, CONV DRIVE SPRKT, 1/4-20 UNC-3A KNURLED CUP PT - INC. W/ITEM 25
27	1	49400-0050	1	49400-0050	1	49400-0050	ASSEMBLY, DRIVE CHAIN, 12-3/8"
28	1	22273-0002	1	22273-0002	1	22273-0002	MASTER LINK, DRIVE CHAIN - INC. W/ITEM 27
29	2	35363	2	38551	2	35322	CRUMB PAN

**PS200VL, PS220VL,  
& PS224VL**

PS200VL, PS220VL,  
& PS224VL

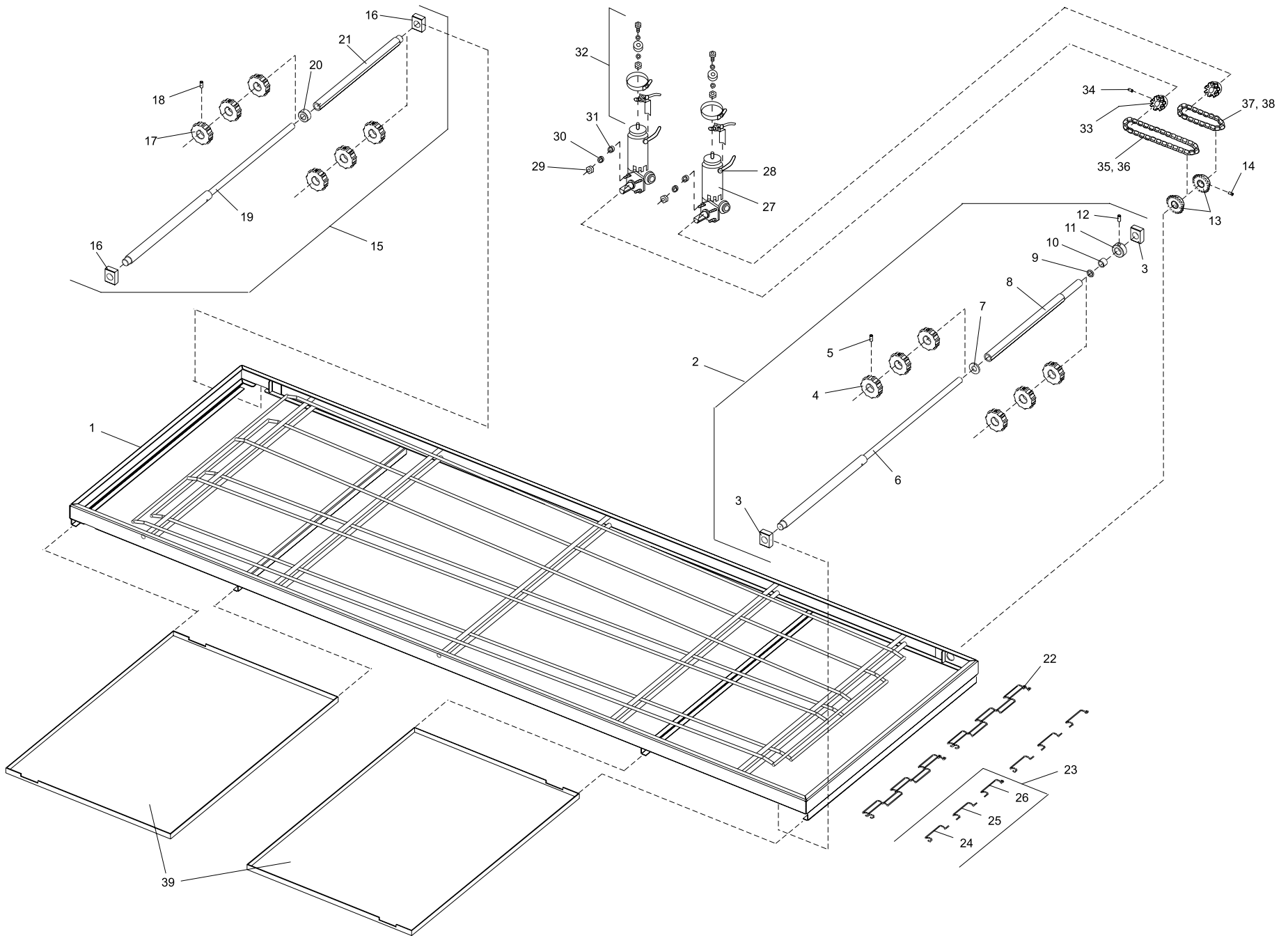

## XII. CONVEYOR ASSEMBLY - SPLIT BELT OVENS

ITEM	PS200VL		PS220VL		PS224VL		DESCRIPTION
	QTY.	P/N	QTY.	P/N	QTY.	P/N	
-	1	37379	1	37690	1	37645	ASSEMBLY, CONVEYOR
1	1	34881	1	37648	1	35272	ASSEMBLY, CONVEYOR FRAME
2	1	37377	1	37680	1	37643	ASSEMBLY, DRIVE SHAFT
3	2	37376	2	37376	2	37376	BUSHING, CONVEYOR
4	8	22229-0003	6	22229-0003	6	22229-0003	SPROCKET, CONVEYOR
5	8	21276-0039	6	21276-0039	6	21276-0039	SET SCREW, CONV SPRKT, 1/4-28 x 1/2" UNF-3A CONE PT - INC. W/ITEM 4
6	1	49400-0018	1	37681	1	49400-0261	DRIVE SHAFT, FRONT
7	1	21415-0001	1	21415-0001	1	21415-0001	WASHER, BRONZE
8	1	35900-0022	1	37683	1	35900-0403	DRIVE SHAFT, REAR
9	1	35000-1531	1	35000-1531	1	35000-1531	NYLON SPACER
10	1	35900-0023	1	35900-0023	1	35900-0023	BUSHING, FRONT DRIVE SPROCKET
11	1	22011-0013	1	22011-0013	1	22011-0013	COLLAR, DRIVE SHAFT
12	1	-	1	-	1	-	SET SCREW, DRIVE SHAFT COLLAR, 5/16-18 x 3/8" UNC-3A CUP PT - INC. W/ITEM 11
13	2	22159-0003	2	22159-0003	2	22159-0003	SPROCKET, DRIVE SHAFT
14	2	-	2	-	2	-	SET SCREW, DR SHAFT SPRKT #10-32 UNF-3A KNURLED CUP PT - INC. W/ITEM 13
15	1	37378	1	37685	1	37644	ASSEMBLY, IDLER SHAFT
16	2	37376	2	37376	2	37376	BUSHING, CONVEYOR
17	8	22229-0003	6	22229-0003	6	22229-0003	SPROCKET, CONVEYOR
18	8	21276-0039	6	21276-0039	6	21276-0039	SET SCREW, CONV SPRKT, 1/4-28 x 1/2" UNF 3-A CONE PT - INC. W/ITEM 17
19	1	42400-0354	1	37686	1	35900-0405	IDLER SHAFT, FRONT
20	1	37898	1	37898	1	37898	SPACER
21	1	35000-1535	1	37689	1	35900-0406	IDLER SHAFT, REAR
22	2	22450-0226	2	36541	2	22450-0204	CONVEYOR BELT, 146" (3708mm)
23	2	42400-0089	2	42400-0589	2	42400-0090	CONVEYOR MASTER LINKS KIT
24	-	-	-	-	-	-	MASTER LINK, LEFT - INC. W/ITEM 23
25	-	-	-	-	-	-	MASTER LINKS, CENTER - INC. W/ITEM 23
26	-	-	-	-	-	-	MASTER LINK, RIGHT - INC. W/ITEM 23
27	2	27384-0011	2	27384-0011	2	27384-0011	MOTOR, CONVEYOR GEAR
28	4	22450-0230	4	22450-0230	4	22450-0230	BRUSHES, CONVEYOR GEAR MOTOR - INC. W/ITEM 27
29	8	21122-0004	8	21122-0004	8	21122-0004	HEX NUT, 10-32
30	8	21421-0003	8	21421-0003	8	21421-0003	WASHER, #10 SPLIT
31	8	21421-0011	8	21421-0011	8	21421-0011	WASHER, #10 FLAT
32	2	27170-0263	2	27170-0263	2	27170-0263	CONVEYOR CONTROL PICKUP KIT
33	2	22159-0004	2	22159-0004	2	22159-0004	SPROCKET, CONVEYOR GEAR MOTOR (30T)
34	2	-	2	-	2	-	SET SCREW, CONV DRIVE SPRKT, 10-24 UNC KNURLED CUP PT - INC. W/ITEM 33
35	1	49400-0051	1	49400-0051	1	49400-0051	ASSEMBLY, REAR DRIVE CHAIN, 26-1/2"
36	1	22273-0003	1	22273-0003	1	22273-0003	MASTER LINK, REAR DRIVE CHAIN - INC. W/ITEM 35
37	1	49400-0070	1	49400-0070	1	49400-0070	ASSEMBLY, FRONT DRIVE CHAIN, 15"
38	1	22273-0002	1	22273-0002	1	22273-0002	MASTER LINK, FRONT DRIVE CHAIN - INC. W/ITEM 38
39	2	35363	2	38551	2	35322	CRUMB PAN

## **WARNING**

**Improper installation, adjustment, alteration, service or maintenance can cause property damage, injury or death. Read the installation, operating and maintenance instructions thoroughly before installing or servicing this equipment.**

### **NOTICE**

During the warranty period, ALL parts replacement and servicing should be performed by your Middleby Marshall Authorized Service Agent. Service that is performed by parties other than your Middleby Marshall Authorized Service Agent may void your warranty.

### **NOTICE**

Using any parts other than genuine Middleby Marshall factory manufactured parts relieves the manufacturer of all warranty and liability.

### **NOTICE**

Middleby Marshall reserves the right to change specifications at any time.

PS200VL, PS220VL,  
& PS224VL

Middleby Cooking Systems Group • 1400 Toastmaster Drive • Elgin, IL 60120 • USA • (847)741-3300 • FAX (847)741-4406

**24-Hour Service Hotline: 1-(800)-238-8444**

***www.middleby.com***

