

SERVICE MANUAL

(DOMESTIC & INTERNATIONAL)

FRIED FOOD HOLDING STATION

FFHS 27000 SERIES



Merco Savory, LLC
1111 North Hadley Road
Fort Wayne, Indiana 46804
United States of America

Phone: (260) 459-8200

U.S. Fax: (888) 790-8193 • Int'l Fax: (260) 436-0735

Technical Service Hot Line
(800) 678-9511

www.mercosvory.com

TABLE OF CONTENTS

CURRENT UNITS (WITH "CENTER" ON/OFF SWITCHES)

SPECIFICATIONS FOR 27000, 27001, 27002.....	3
SPECIFICATIONS FOR 27007, 27008, 27012, 27014.....	4
SPECIFICATIONS FOR 27016 (with remote switch).....	5
WIRING DIAGRAMS.....	6
SEQUENCE OF OPERATIONS.....	7
REMOVAL INSTALLATION & ADJUSTMENTS (27000, 27001, 27002).....	8
REMOVAL INSTALLATION & ADJUSTMENTS (27007, 27008, 27012, 27014, 27016).....	10
PARTS BREAKDOWN (27007, 27008, 27012, 27014, 27016).....	12
EXPLODED VIEW DIAGRAM (27007, 27008, 27012, 27014, 27016).....	13
PARTS BREAKDOWN (27000, 27001, 27002).....	14
EXPLODED VIEW DIAGRAM (27000, 27001, 27002).....	15

OUTDATED UNITS (WITH "RIGHT-SIDE" ON/OFF SWITCHES)

SEQUENCE OF OPERATIONS (27000, 27002).....	17
SPECIFICATIONS (27000, 27002).....	17
WIRING DIAGRAMS (27000, 27002).....	18
SEQUENCE OF OPERATIONS (27007, 27012).....	19
SPECIFICATIONS (27007, 27012).....	19
WIRING DIAGRAM (27007, 27012).....	19
PARTS BREAKDOWN (27000, 27002 – S/N 1083327 & BELOW).....	20
EXPLODED VIEW DIAGRAM (27000, 27002 – S/N 1083327 & BELOW).....	21
PARTS BREAKDOWN (27000, 27002 – S/N 1083328 & ABOVE).....	22
EXPLODED VIEW DIAGRAM (27000, 27002 – S/N 1083328 & ABOVE).....	23
PARTS BREAKDOWN (27007, 27012).....	24
EXPLODED VIEW DIAGRAM (27007, 27012).....	25
REMOVAL INSTALLATION & ADJUSTMENTS (27000, 27002).....	26
REMOVAL INSTALLATION & ADJUSTMENTS (27007, 27012).....	31

SPECIFICATIONS FOR 27000, 27001, 27002, 27017

Item #	Voltage	Amps	Watts	Hz	Phase	Cord/Plug
27000	208 VAC	21.6	4500	60	1	6' NEMA L6-30P
27001	208 VAC	21.6	4500	60	1	6' NEMA L6-30P
27002	240 VAC	18.8	4500	60	1	6' NEMA L6-30P
27017*	208 VAC	21.6	4500	60	1	6' NEMA L6-30P

*27017 includes drop-in shelf.

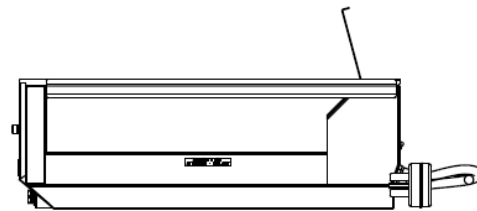
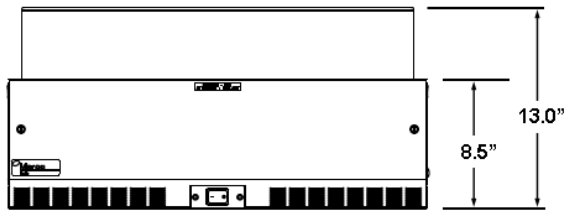
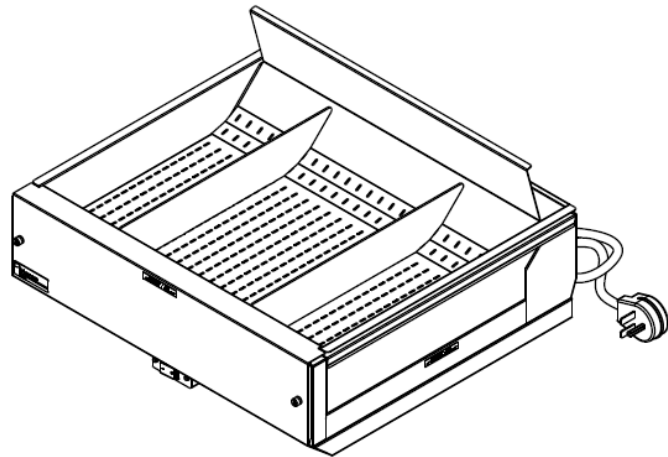
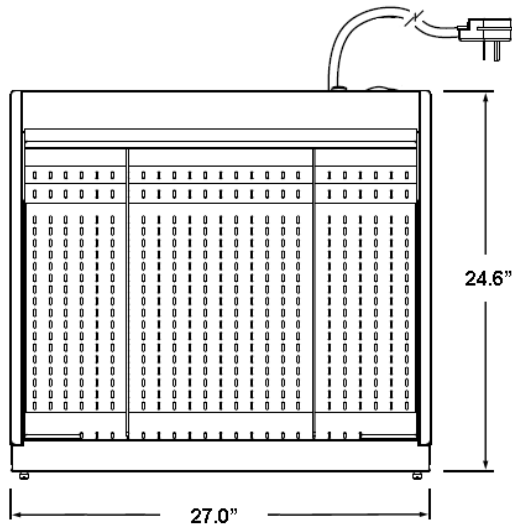

SPECIFICATIONS FOR 27007, 27008, 27012, 27016

Item	Voltage	Amps	Watts	Hz	Phase	Cord/Plug
27007	120 VAC	12.0	1450	60	1	5' NEMA 5-15P
27008 (CE)	230 VAC	7.5				N/A
27012	120 VAC	15.4	1860	60	1	5' NEMA 5-20P
27016*	120 VAC	12.0	1450	60	1	5' NEMA 5-20P

*27016 includes drop-in shelf.

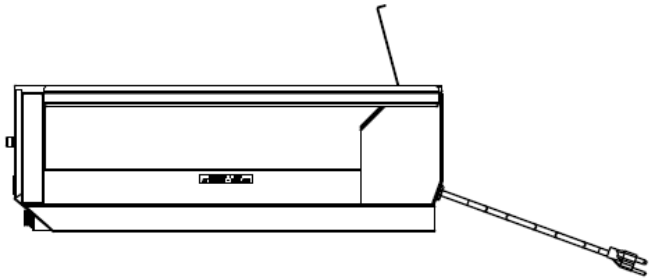
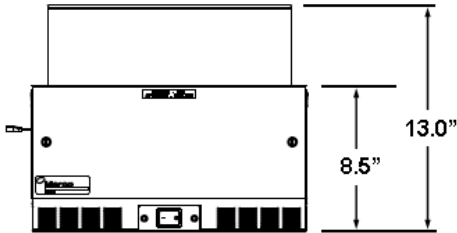
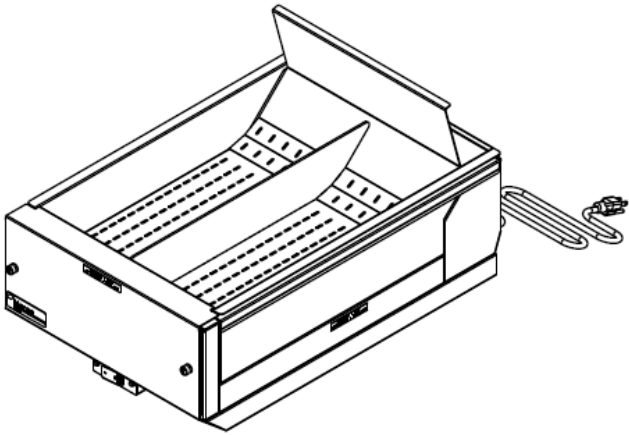
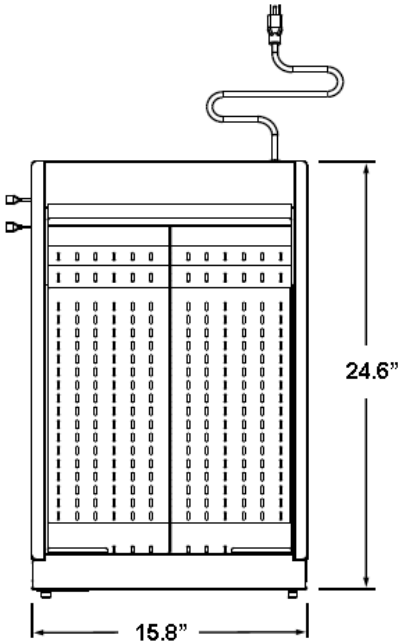

SPECIFICATIONS FOR 27016 with Remote Switch

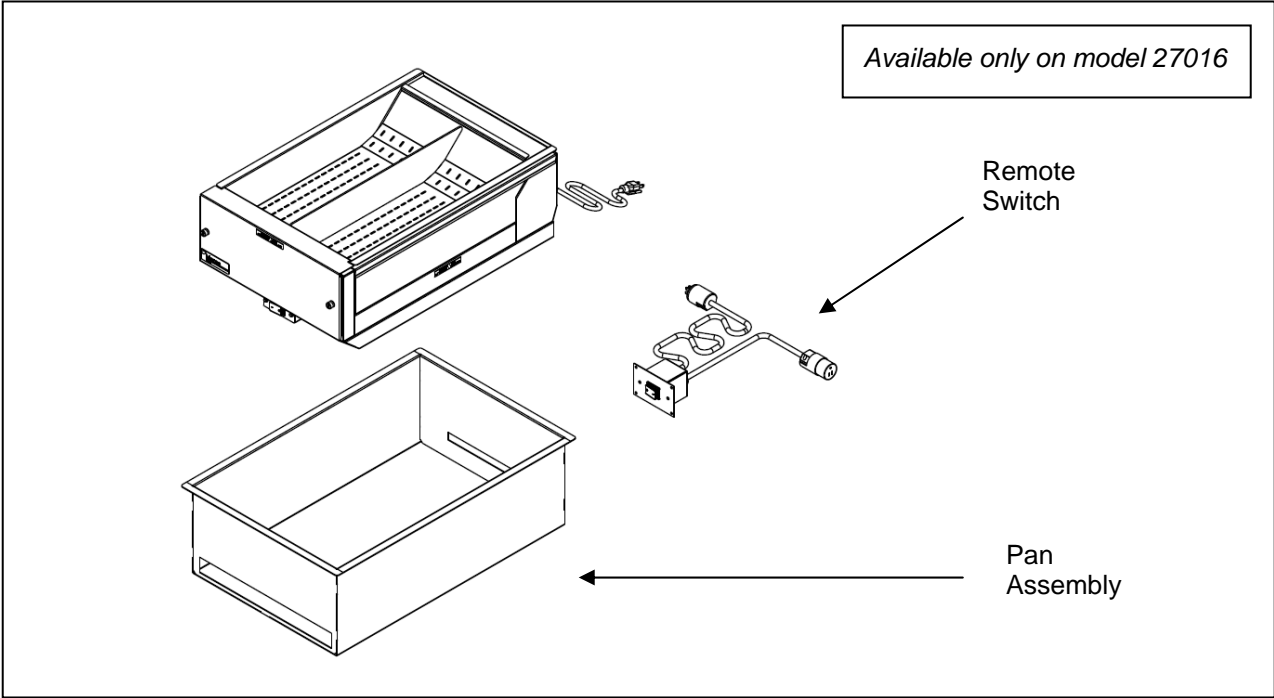

SPECIFICATIONS FOR 27017 with Remote Switch

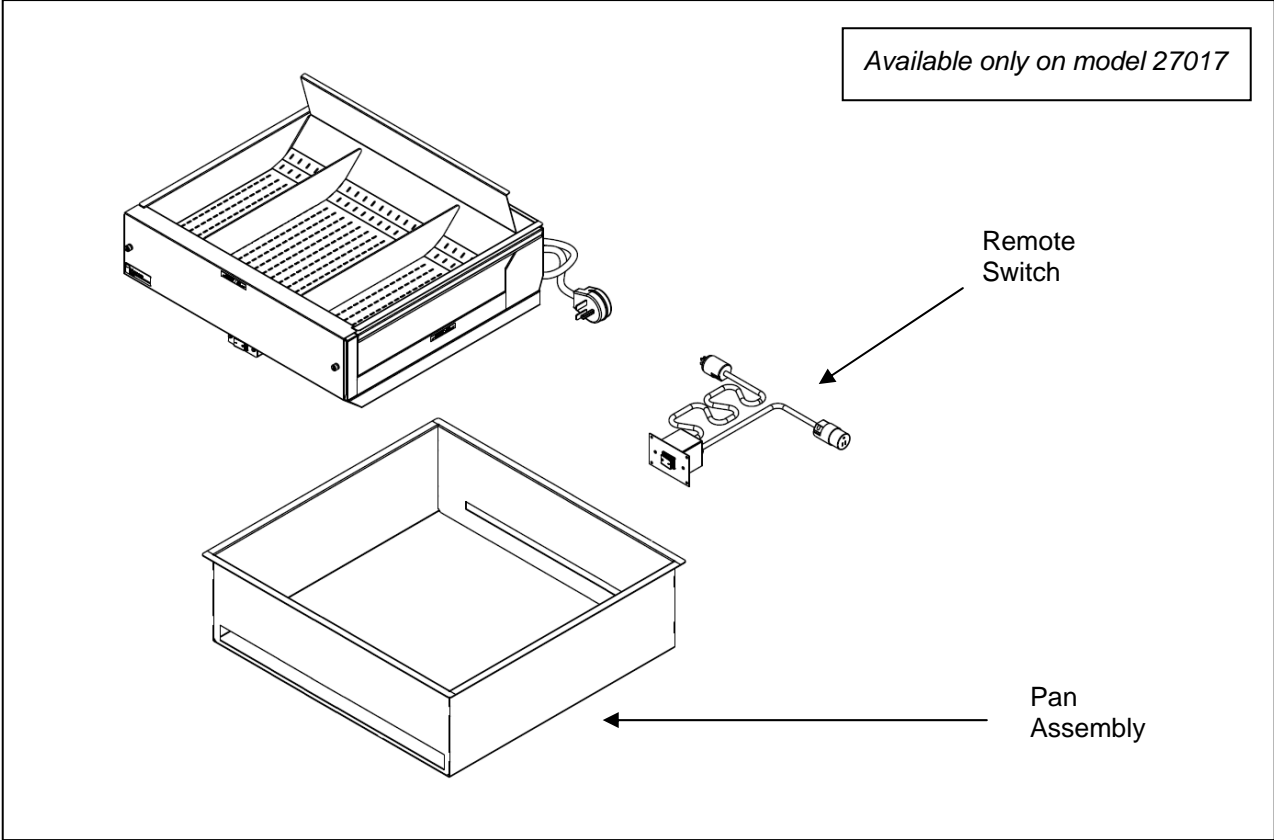

**SEQUENCE OF OPERATIONS
MODELS 27000, 27001, 27002**

Power Supply	<p>Electrical power is supplied to the unit by a 3 conductor service for single phase. Black conductor is hot. White conductor is neutral. Green and yellow conductor is ground. Power is permanently supplied to one of the normally open contacts of the main switch, also to the normally open contacts of relay and the normally open cool down thermostat.</p>
Heating Circuit	<p>Closing the main power switch supplies power to the coils of relays, power is supplied to the main fan motor. The contacts of R1 and R2 close supplying power to the main heater.</p>
Cool Down Circuit	<p>As the temperature reaches 200°F, the cool down thermostat closes. When the main switch is turned off, the main fan will continue to run until the temperature drops to 160°F.</p>

**SEQUENCE OF OPERATIONS
MODELS 27007, 27008, 27012, 27016**

Power Supply	<p>Electrical power is supplied to the unit by a 3 conductor service for single phase. Black conductor is hot. White conductor is neutral. Green and yellow conductor is ground. Power is permanently supplied to one of the normally open contacts of the main switch also to one side of the normally open contacts of the main heater relay.</p>
Heating Circuit	<p>Closing the main power switch feeds power through the normally closed high limit thermostat to the coil of the main relay. Its contacts now close supplying power to the main heater. Also for air circulation power is supplied to the main fan motor.</p>

REMOVAL, INSTALLATION AND ADJUSTMENTS (NEW STYLE CENTER SWITCH UNITS)

MODELS 27000, 27001, 27002



CAUTION:

Disconnect power supply before servicing or cleaning this toaster. Safeguard power so it cannot be accidentally restored. Failure to do so could result in dismemberment, electrocution, or fatal injury.

SWITCH, ON-OFF

1. Remove screws from face of switch mounting plate.
2. Disconnect wires from switch assembly. Mark wires for reinstallation.
3. Depress clips on side of switch and remove switch from panel.
4. Install new part, reassemble in reverse order, and check operation.

SWITCH, COOL-DOWN MOTOR

1. Lift and set aside pan tray and grease pan weldment.
2. Remove screws from both left and right outer formed panels.
3. Lift and set aside blower cover weldment.
4. Remove exhaust panel by sliding forward (toward on/off switch) and set panel aside.
5. Remove inner formed base by sliding forward (toward on/off switch).
6. Disconnect wires from end of cool-down motor switch. Mark wires for reinstallation.
7. Remove screws from cool-down motor switch to remove switch.
8. Install new part, reassemble in reverse order, and check operation.

HIGH LIMIT THERMOSTAT

1. Lift and set aside pan tray and grease pan weldment.
2. Remove fourteen (14) screws from both left and right outer formed panels.
3. Lift and set aside blower cover weldment.
4. Remove exhaust panel by sliding forward (toward on/off switch) and set panel aside.
5. Remove inner formed base by sliding forward (toward on/off switch).
6. Disconnect two (2) wires from end of high limit thermostat. Mark wires for reinstallation.
7. Remove two (2) screws from the high limit to remove thermostat.
8. Install new part, reassemble in reverse order, and check operation.

POWER CORD 250V 30A

1. Lift and set aside pan tray and grease pan weldment.
2. Remove screws from both left and right outer formed panels.
3. Lift and set aside blower cover weldment.
4. Disconnect power cord L1 and L2 wires from wire terminal connections. Mark wires for reinstallation.
5. Remove ground nut from power cord ground wire.
6. Compress cord strain relief to remove power cord from bracket.
7. Install new part, reassemble in reverse order, and check operation.

HEATER 208V, 240V

1. Lift and set aside pan tray and grease pan weldment.
2. Remove screws from both left and right outer formed panels.
3. Lift and set aside blower cover weldment.
4. Remove exhaust panel by sliding forward (toward on/off switch) and set panel aside.
5. Remove inner formed base by sliding forward (toward on/off switch).
6. Remove screws from element bracket.
7. Loosen screws from air duct base next to element bracket for element removal.
8. Disconnect wires from heater and remove heater. Mark wires for reinstallation.
9. Install new part, reassemble in reverse order, and check operation.

BLOWER

1. Lift and set aside pan tray and grease pan weldment.
2. Remove screws from both left and right outer formed panels.
3. Lift and set aside blower cover weldment.
4. Disconnect wires from blower. Mark wires for reinstallation.
5. Remove nuts from base of blower assembly and remove blower assembly.
6. Install new part, reassemble in reverse order, and check operation.

POWER RELAY

1. Lift and set aside pan tray and grease pan weldment.
2. Remove screws from both left and right outer formed panels.
3. Lift and set aside blower cover weldment.
4. Disconnect wires from relay. Mark wires for reinstallation.
5. Remove screws from relay and remove power relay.
6. Install new part, reassemble in reverse order, and check operation.

REMOVAL, INSTALLATION AND ADJUSTMENTS (NEW STYLE CENTER SWITCH UNITS)

MODELS 27007, 27008, 27012, 27016



CAUTION:

Disconnect power supply before servicing or cleaning this toaster. Safeguard power so it cannot be accidentally restored. Failure to do so could result in dismemberment, electrocution, or fatal injury.

SWITCH, ON-OFF

1. Remove two (2) screws from face of switch mounting plate.
2. Disconnect three (3) wires from switch assembly. Mark wires for reinstallation.
3. Depress clips on side of switch and remove switch from panel.
4. Install new part, reassemble in reverse order, and check operation.

POWER CORD 120V

1. Lift and set aside pan tray and grease pan weldment.
2. Remove fourteen (14) screws from both left and right outer formed panels.
3. Lift and set aside blower cover weldment.
4. Disconnect power cord neutral and L1 wires from in-line wire terminal connections. Mark wires for reinstallation.
5. Remove ground nut from power cord ground wire.
6. Compress cord strain relief to remove power cord from bracket.
7. Install new part, reassemble in reverse order, and check operation.

HEATER 120V

1. Lift and set aside pan tray and grease pan weldment.
2. Remove fourteen (14) screws from both left and right outer formed panels.
3. Lift and set aside blower cover weldment.
4. Remove six (6) screws from air intake baffle.
5. Remove two (2) screws from bottom of exhaust panel and set panel aside.
6. Remove inner formed base by sliding forward (toward on/off switch).
7. Remove three (3) screws from base of blower assembly.
8. Remove two (2) screws from both left and right air duct fillers.
9. Slide out blower and heater assembly from blower seal bracket.
10. Remove four (4) screws from side of heater to separate heater from blower.
11. Disconnect two (2) wires from heater and remove heater. Mark wires for reinstallation. Note the path of the wires for reinstallation.
12. Install new part, reassemble in reverse order, and check operation.

BLOWER

1. Lift and set aside pan tray and grease pan weldment.
 2. Remove fourteen (14) screws from both left and right outer formed panels.
 3. Lift and set aside blower cover weldment.
 4. Disconnect two (2) wires from blower. Mark wires for reinstallation.
 5. Remove three (3) screws from base of blower assembly.
 6. Remove two (2) screws from both left and right air duct fillers.
 7. Slide out blower and heater assembly from blower seal bracket.
 8. Remove four (4) screws from side of heater to separate heater from blower.
- Install new part, reassemble in reverse order, and check operation.

POWER RELAY

1. Lift and set aside pan tray and grease pan weldment.
2. Remove screws from both left and right outer formed panels.
3. Lift and set aside blower cover weldment.
4. Disconnect wires from relay. Mark wires for reinstallation.
5. Remove screws from relay and remove power relay.
6. Install new part, reassemble in reverse order, and check operation.

**PARTS BREAKDOWN – FFHS-16
MODELS 27007, 27008, 27012, 27016**

LETTER	PART #	DESCRIPTION
A	27511SP	Lighted Rocker Switch
B	340091	Panel, Switch, FFHS
C	340092	Air Duct Subassembly
D	27120	Outer Panel, Left
E	27045-1	Divider
F	27375-4	Tray, Full Pan, welded – <i>models 27007, 27008, 27012, 27014</i>
	27375-5	Tray, Full Pan, welded – <i>model 27016</i>
G	27370-3	Pan, Grease, Weldment – <i>models 27007, 27008, 27012, 27016</i>
	27370-4	Pan, Grease, Weldment – <i>model 27014</i>
H	27080-3	Inner Base Formed
I	27125	Outer Panel, Right
J	340024	Bush., .875, Snap Universal
K	340088	T-Disc, 240/275 F, NC
	000496	Copaco Paper, .015" x 2" x 7.75"
L	27115-3	Blower Cover Weldment
M	340028	Blower Assembly – <i>models 27007, 27014, 27016</i>
	340093	Blower Assembly – <i>model 27008</i>
	340094	Blower Assembly – <i>model 27012</i>
	340063	Heater, 1850 W 120V <i>only</i> – <i>model 27012</i>
N	340095	Power Cord – <i>models 27007, 27014</i>
	340096	Power Cord – <i>model 27012</i>
	340097	Power Cord – <i>model 27016</i>
O	340089	Relay, DPST, 25A, 120V
P	340098	Relay Bracket, FFHS-16
Q	000171	Heyco Bushing
R	340099	Front Cover Assembly
S	340100	Exhaust Vent Subassembly
T	000696	Label, "Caution Hot" (English/French)
Not Shown	10001503	Remote Switch – <i>model 27016 only</i>
Not Shown	4040266-1	Heater – <i>models 27007, 27014, 27016</i>
Not Shown	4040266-2	Heater – <i>model 27008</i>
Not Shown	4040266-3	Heater – <i>model 27012</i>
Not Shown	4060505-1	Blower – <i>models 27007, 27014, 27016</i>
Not Shown	4060505-2	Blower – <i>model 27008</i>
Not Shown	4060505-3	Blower – <i>model 27012</i>

**GENERAL VIEW – FFHS-16
MODELS 27007, 27008, 27012, 27016**

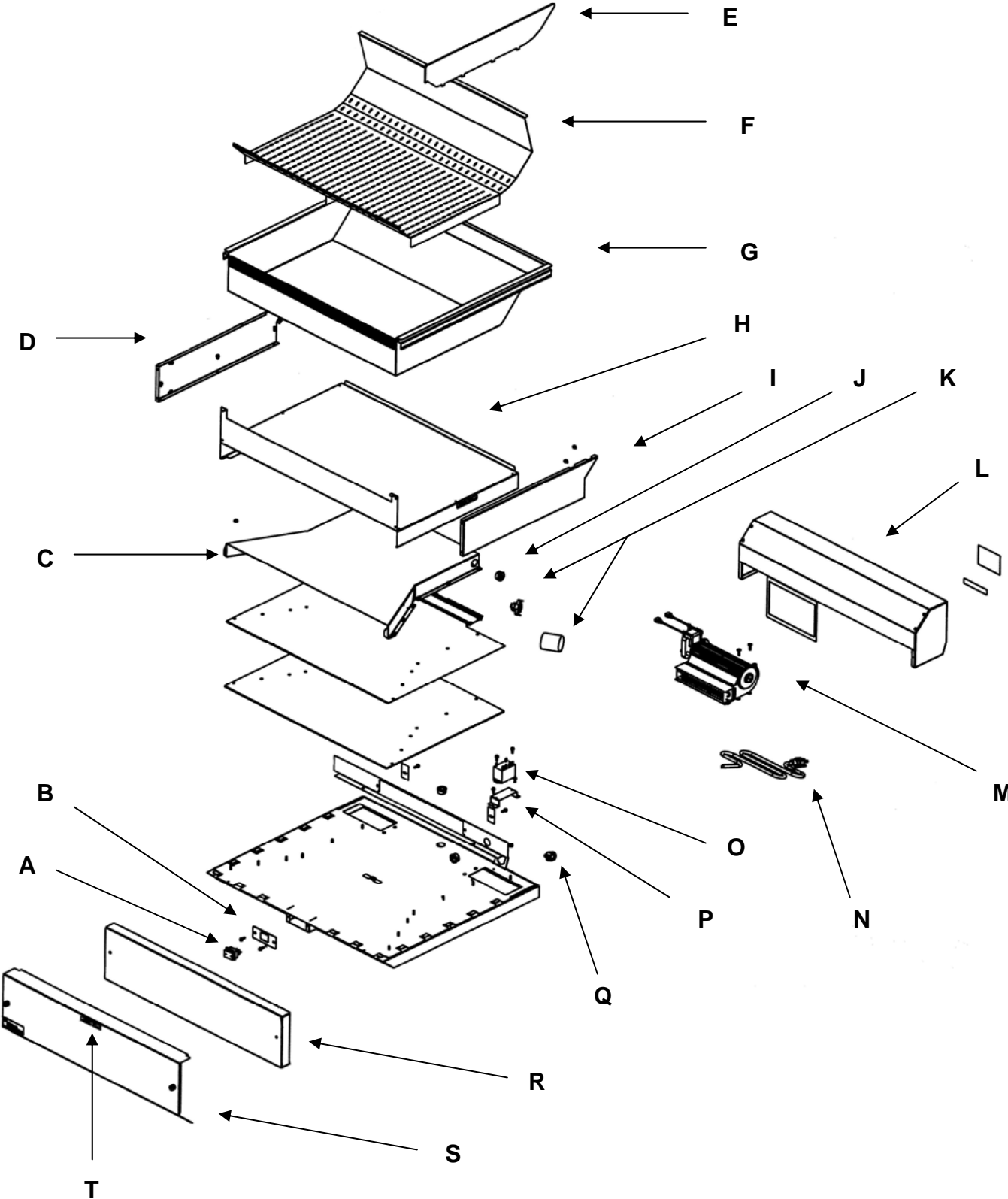

**PARTS BREAKDOWN – FFHS-27
MODELS 27000, 27001, 27002, 27017**

LETTER	PART #	DESCRIPTION
A	340087	Switch, Sealed, Illum, Grn
B	340091	Panel, Switch, FFHS
C	340101	Air Duct Subassembly
D	27120	Outer Panel, Left
E	27045-1	Divider
F	27375-1	Tray, Full Pan, Welded – <i>models 27000 & 27002</i>
	27375-2	Tray, Full Pan, Welded – <i>model 27001</i>
G	27370-1	Pan, Grease, Weldment
H	27080-1	Inner Base Formed
I	27125	Outer Panel, Right
J	340024	Bush., .875 Snap Universal
K	000496	Copaco Paper, .015"x2"x 7.75"
L	27115-1	Blower Cover Weldment
M	340058	Blower / Heater Assembly – <i>models 27000 & 27001</i>
	340061	Blower / Heater Assembly – <i>model 27002</i>
	340060	Tang Blower <i>only</i> – <i>models 27000, 27001, 27002</i>
	340059	Heater, 4500 W 208V <i>only</i> – <i>models 27000 & 27001</i>
	340062	Heater, 4500 W 240V <i>only</i> – <i>model 27002</i>
N	27280	Cord Assembly, FFHS 208/240V
O	27240	Power Relay, 240V
P	340102	Relay Bracket, FFHS-27
Q	27235	Bush., STR. REL., 10/3, S
R	340103	Front Cover Assembly
S	340104	Exhaust Vent Subassembly
T	000696	Label, Caution-Hot, FR/ENG
Not Shown	27485	Motor Cool-down Switch
Not Shown		Drop-In Shelf – <i>model 27017 only</i>
Not Shown	10002777-01	Heater – <i>models 27000 & 27002</i>
Not Shown	10002777-02	Heater – <i>model 27001</i>
Not Shown	10002776-01	Blower – <i>models 27000 & 27002</i>
Not Shown	10002776-01	Blower – <i>model 27001</i>

**GENERAL VIEW – FFHS-27
MODELS 27000, 27001, 27002, 27017**

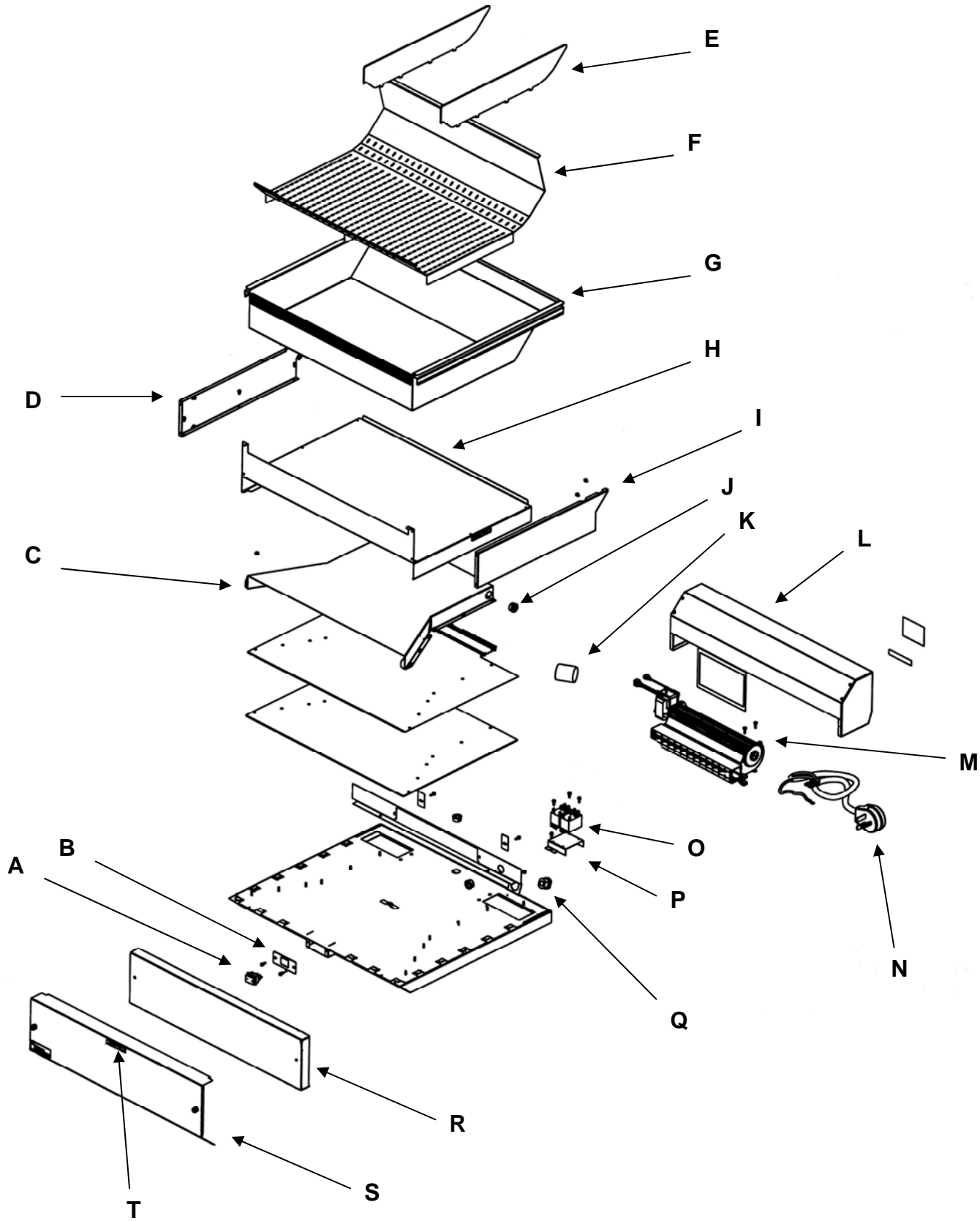

THE FOLLOWING MODELS (WITH RIGHT-SIDE SWITCHES) ARE NO LONGER IN PRODUCTION.

SEQUENCE OF OPERATION 27000, 27002

Power is permanently supplied to the normally open contacts of the main relay. Power is also supplied to the normally open power switch. Closing the power switch supplies power through the normally closed hi-limit thermostat to the electronic control board. Power is also supplied to the coil of the main relay. When the main relay is energized, the contacts close supplying power to the contacts of the solid state relay. When the electronic control is energized, voltage is supplied to the blower motor. The RTD probe senses air temperature. The electronic temperature control supplies power to the solid state relay. When the relay contacts close, power is supplied to the heating element. The solid state relay will cycle on and off to maintain the proper temperature.

SPECIFICATIONS 27000, 27002 S/N 1083327 & BELOW

Item #	Voltage	Amps	Watts	Cord/Plug	Net Wt.
27000	208 VAC	26.4	5500	6' NEMA L6-30P	76 lbs.
27002	240 VAC	22.9	5500	6' NEMA L6-30P	76 lbs.

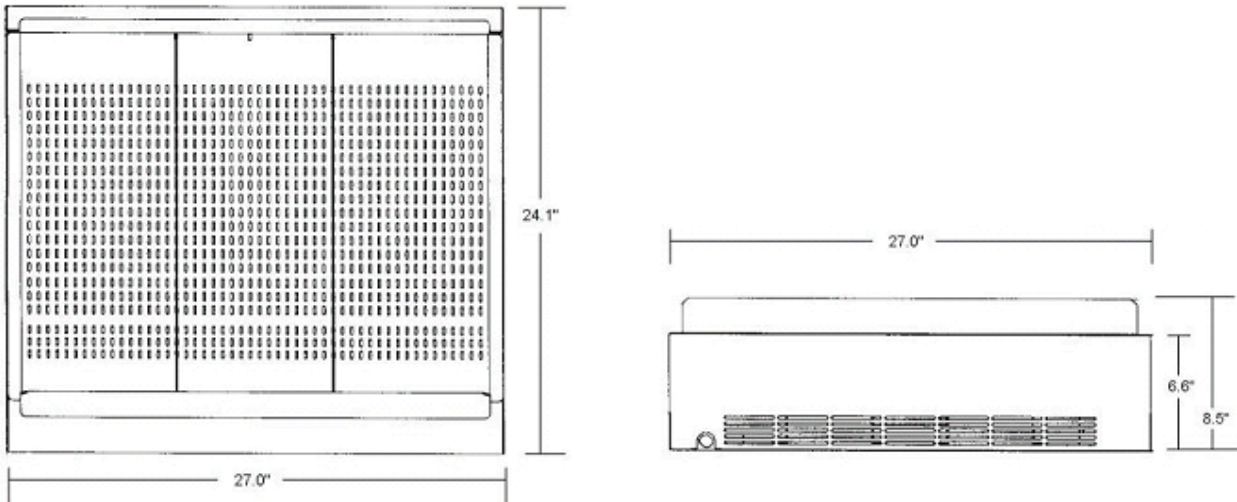

SPECIFICATIONS 27000, 27002 S/N 1083328 & ABOVE

Item #	Voltage	Amps	Watts	Cord/Plug	Net Wt.
27000	208 VAC	24.0	5500	6' NEMA L6-30P	66 lbs.
27002	240 VAC	22.9	5500	6' NEMA L6-30P	66 lbs.

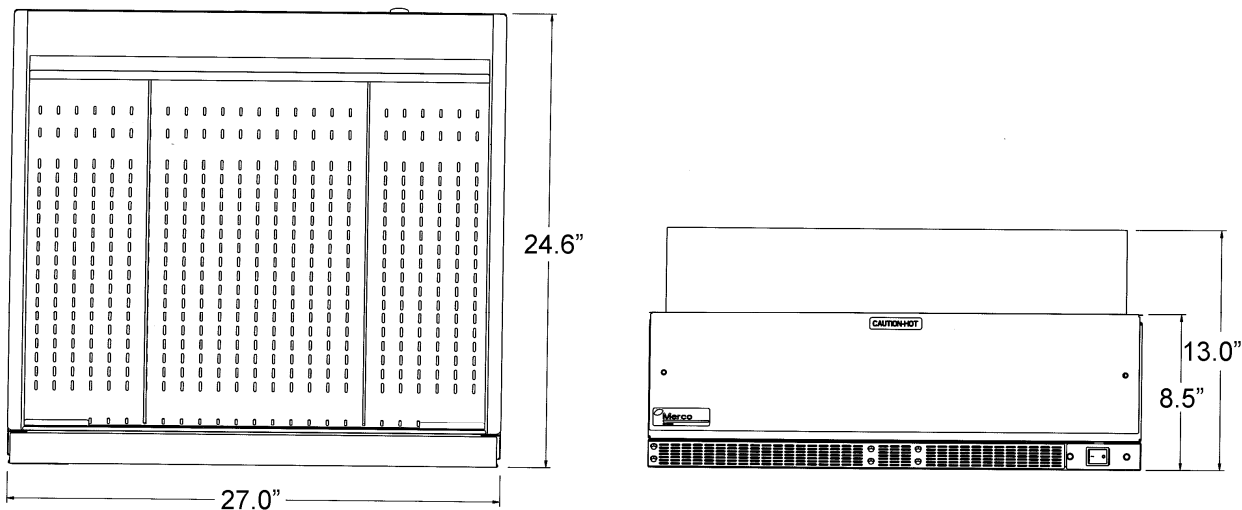

WIRING DIAGRAM – MODELS 27000, 27002 S/N 1083327 & BELOW

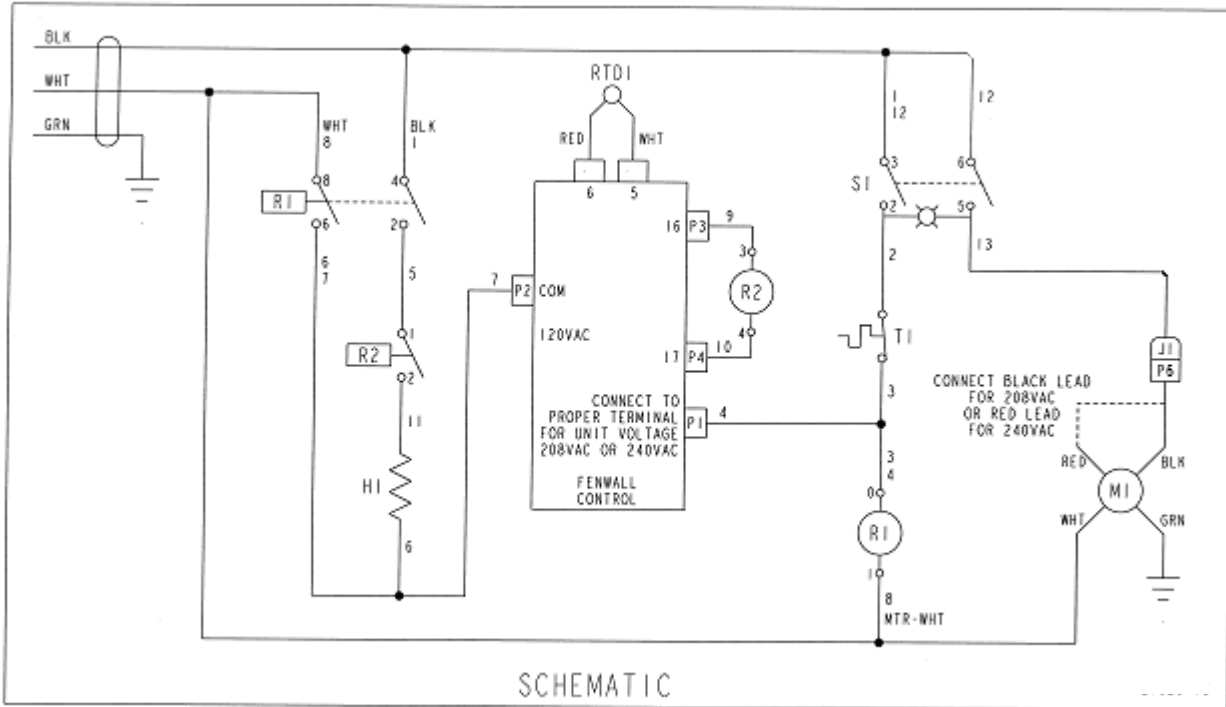

WIRING DIAGRAM – MODELS 27000, 27002 S/N 1083328 & ABOVE

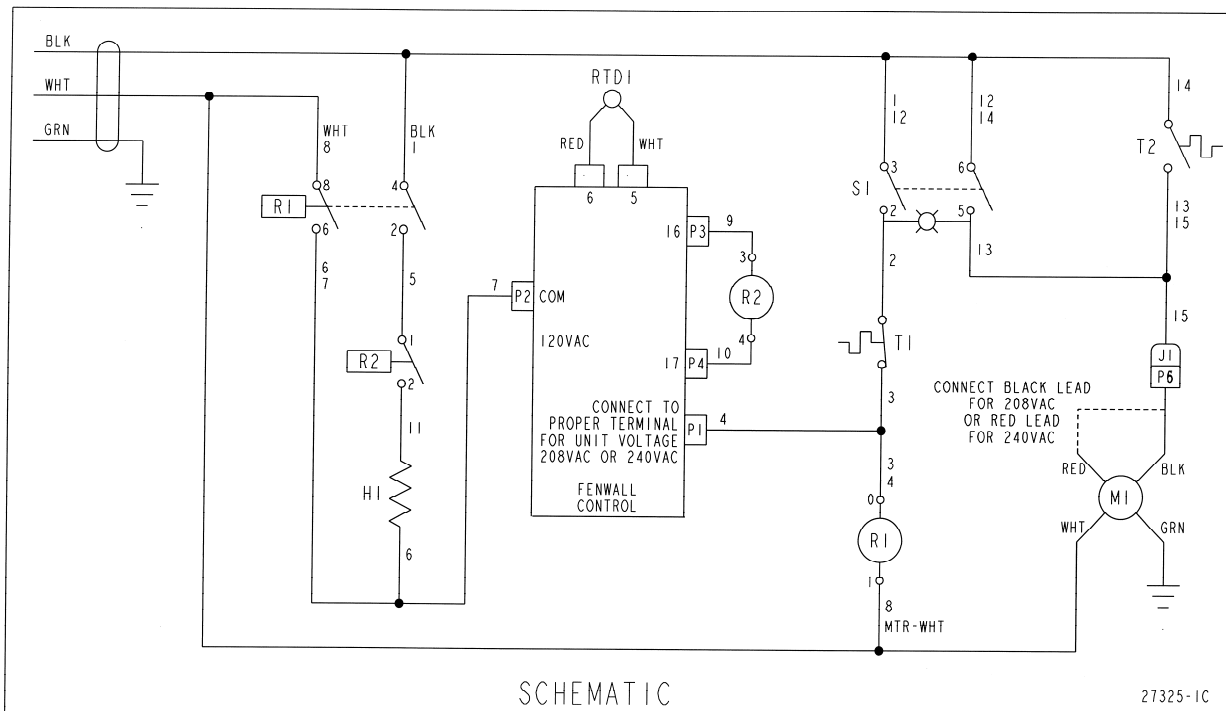

SEQUENCE OF OPERATION 27007, 27012

Power is supplied to the normally open power switch. Closing the power switch supplies power through the normally closed hi-limit thermostat to the blower motor and to the heating element.

SPECIFICATIONS 27007, 27012

Item	Voltage	Amps	Watts	Cord/Plug	Net Wt.
27007	120 VAC	12.3	1450	5' NEMA 5-15P	44 lbs.
27012	120 VAC	15.7	1850	5' NEMA 5-20P	44 lbs.

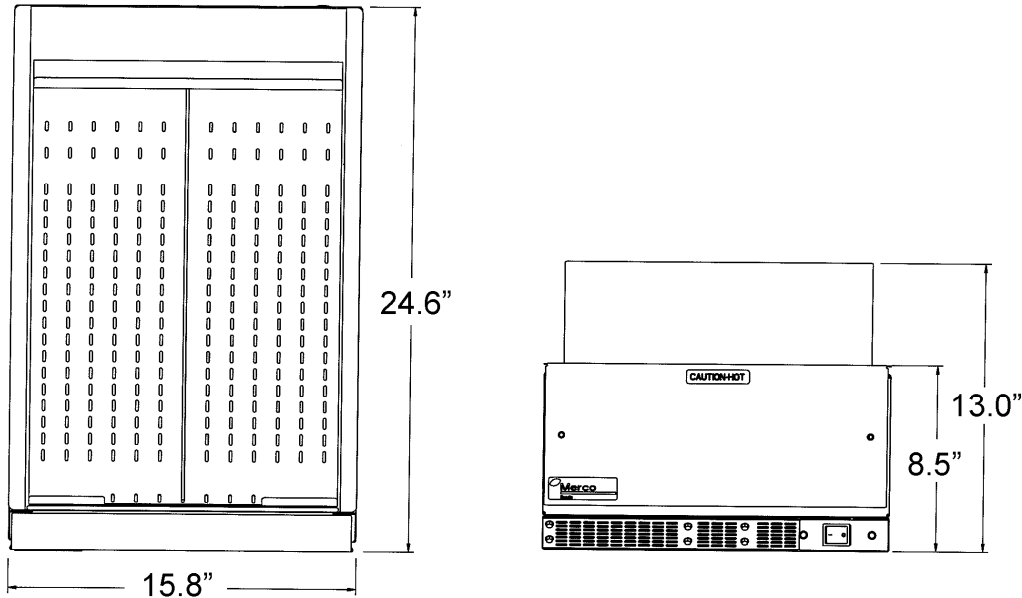

WIRING DIAGRAM – MODELS 27007, 27012

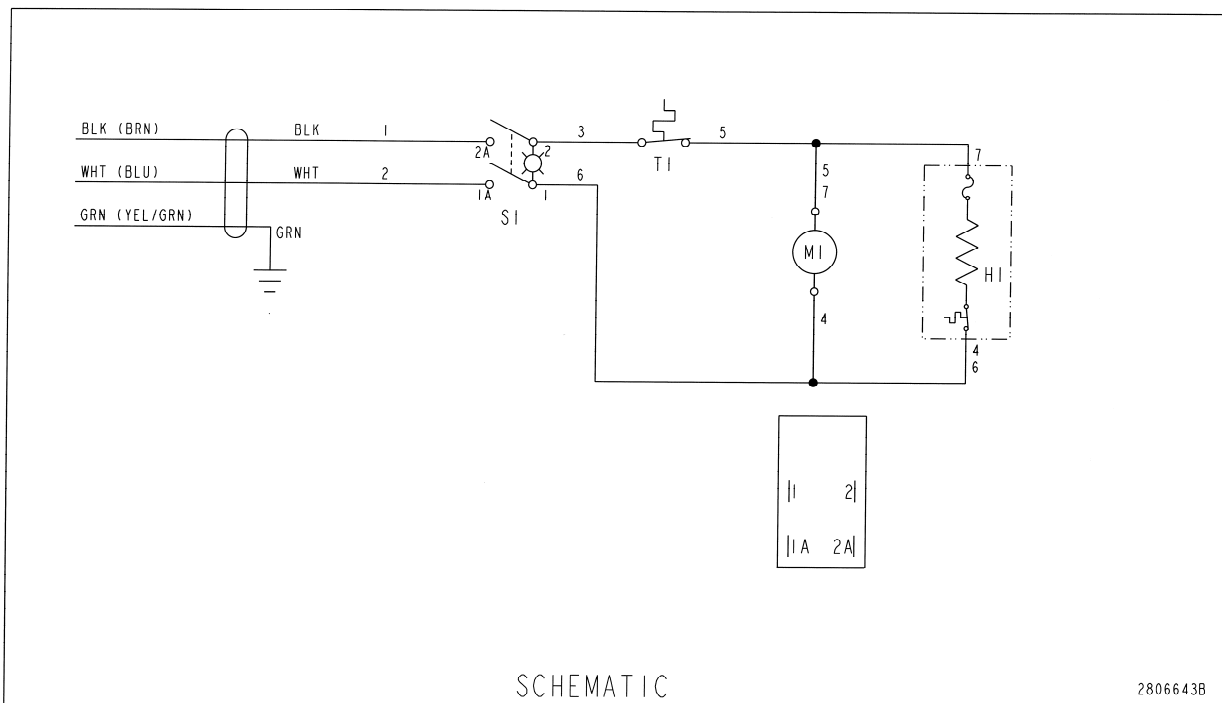

PARTS BREAKDOWN – MODELS 27000, 27002 S/N 1083327 & BELOW

LETTER	PART #	DESCRIPTION
A	27155	Tray, Weldment
B	27355	Drip Pan
C	27130	Inner Panel (left)
	27135	Inner Panel (right)
D	27120	Outer Panel (left)
	27125	Outer Panel (right)
E	27080	Inner Base
F	27170	Insulation, Air Duct
G	27050	Air Baffle
H	27025	Element Top Panel
I	27060	Divider Plate (left)
	27065	Divider Plate (right)
J	27230	Plug, Twist Lock, 30A, 250V, not CE
	370019	Cord and Plug, 50A, (Canada only)
K	27110	Element, Heater 208V
	27040	Element, Heater 240V
L	27115	Motor Housing Cover
M	27420	On / Off Switch
N	27185	Electronic Control
O	27175	Bracket (SSR & Control)
P	27075	Blower Motor
Q	27240	Power Relay
R	27235	Bushing, Strain Relief (not CE)
	27370	Bushing, Strain Relief (CE only)
S	27010	Base
T	27280	Cord, (not CE)
	NLA	Cord, (CE only)
U	27030	Spacer Plate, Insulation, Top
V	27090	Insulation, Base
W	27195	Air Scoop
X	27035	Insulation, Front
Y	27095	Exhaust Panel
Z	27225	Exhaust Panel Guard
AA	27145	Captive Screw
BB	27180	Solid State Relay
Not Shown	27182	Heat Sink
Not Shown	27275	Captive Screw Retainer
Not Shown	41087	Leg, 1"
Not Shown	27045	Pan Dividers
Not Shown	27320	Grease Deflector (left)
Not Shown	27315	Grease Deflector (right)
Not Shown	27055	Hi-Limit
Not Shown	27205	RTD Probe

GENERAL VIEW – MODELS 27000, 27002 S/N 1083327 & BELOW

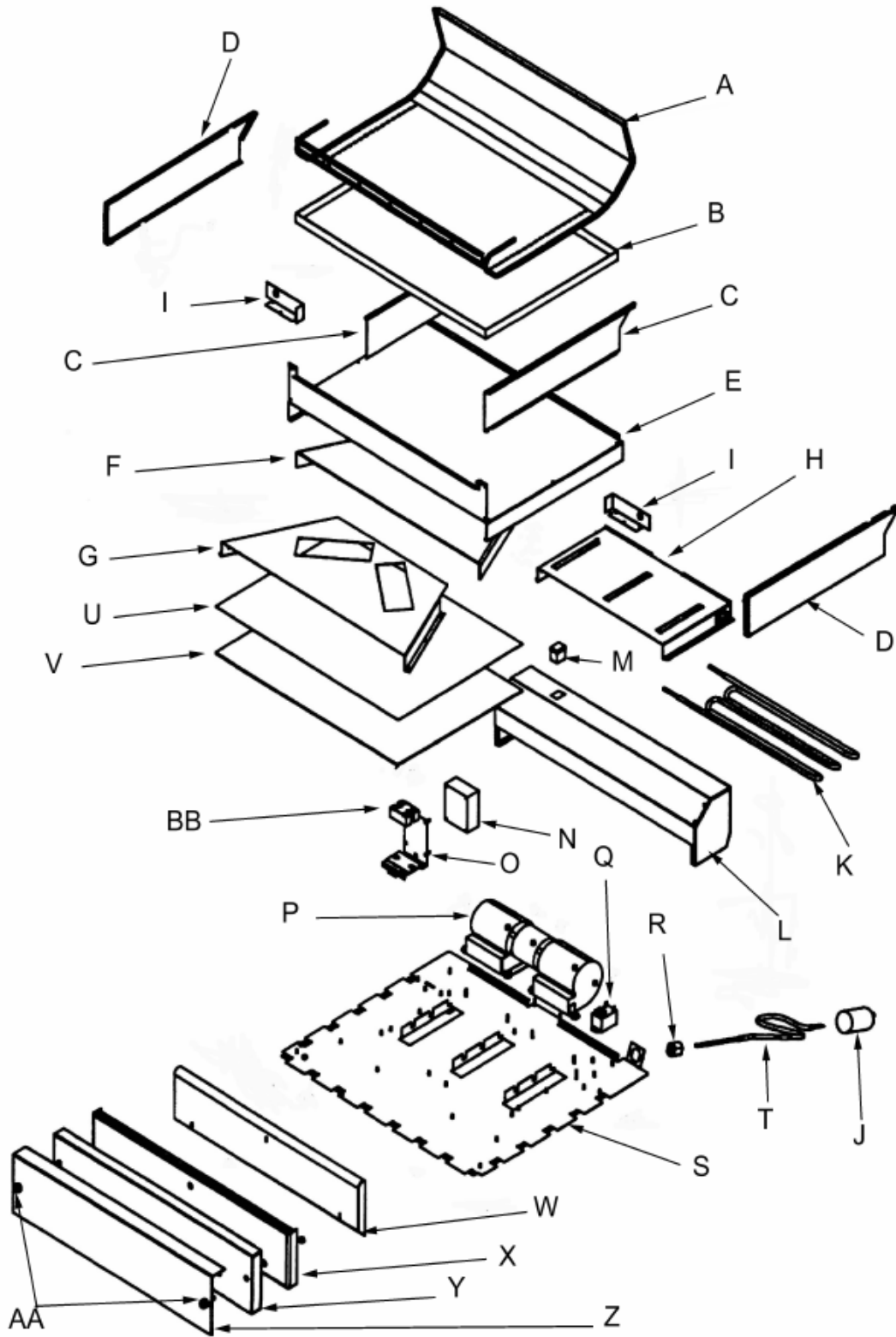

PARTS BREAKDOWN – MODELS 27000, 27002 S/N 1083328 & ABOVE

LETTER	PART #	DESCRIPTION
A	27375-1	Tray, Full Pan
B	27370-1	Grease Pan Weldment Collapsed
C	27080-1	Inner Base, Formed
D	27125	Outer Panel, Right, Formed
E	27115-1	Blower Cover Weldment
F	27503	Gasket, Blower
G	27075	Blower, 208/240V
H	27185	Control Electronic, 230F
I	27180	Solid State Relay, 240V
J	27182	Heat Sink
K	27240	Power Relay
L	27280	Plug, Twist Lock, 30A, 250V, Cord
M	7008234	Bracket, Electronics
N	7008233-1	Bracket, Blower Seal
O	27501	Element, Heater 208V, 5325W
	27502	Element, Heater 240V, 5325W
P	27010-1	Base Cover Weldment
R	27485	Switch, Cool Down Motor
S	10000392	Thermostat, Hi Limit 300F
T	7008236	Plate, Switch Mounting
U	369805	Switch, Rocker, Lighted (old style)
	27511	Switch, Rocker, Lighted (new style)
V	(see W)	Baffle Air Intake
W	27225-1	Exhaust Panel Guard, Formed
X	27095-1	Exhaust Panel, Formed
Y	27035-1	Insulation, Air Scoop C & F
Z	27195-1	Air Scoop, Formed
AA	27090-1	Insulation, Base, Cut
AB	27020-1	Spacer Plate, Insul, Bottom
AC	(see AF)	Baffle Air Duct
AD	27205	Probe, 1000 OHM 1/8" DIA
AE	27105	RTD Holding Bracket Nest
AF	9005267-1	Duct, Air
AG	27120	Outer Panel, Left, Formed
AH	27045-1	Divider Pan

GENERAL VIEW – MODELS 27000, 27002 S/N 1083328 & ABOVE

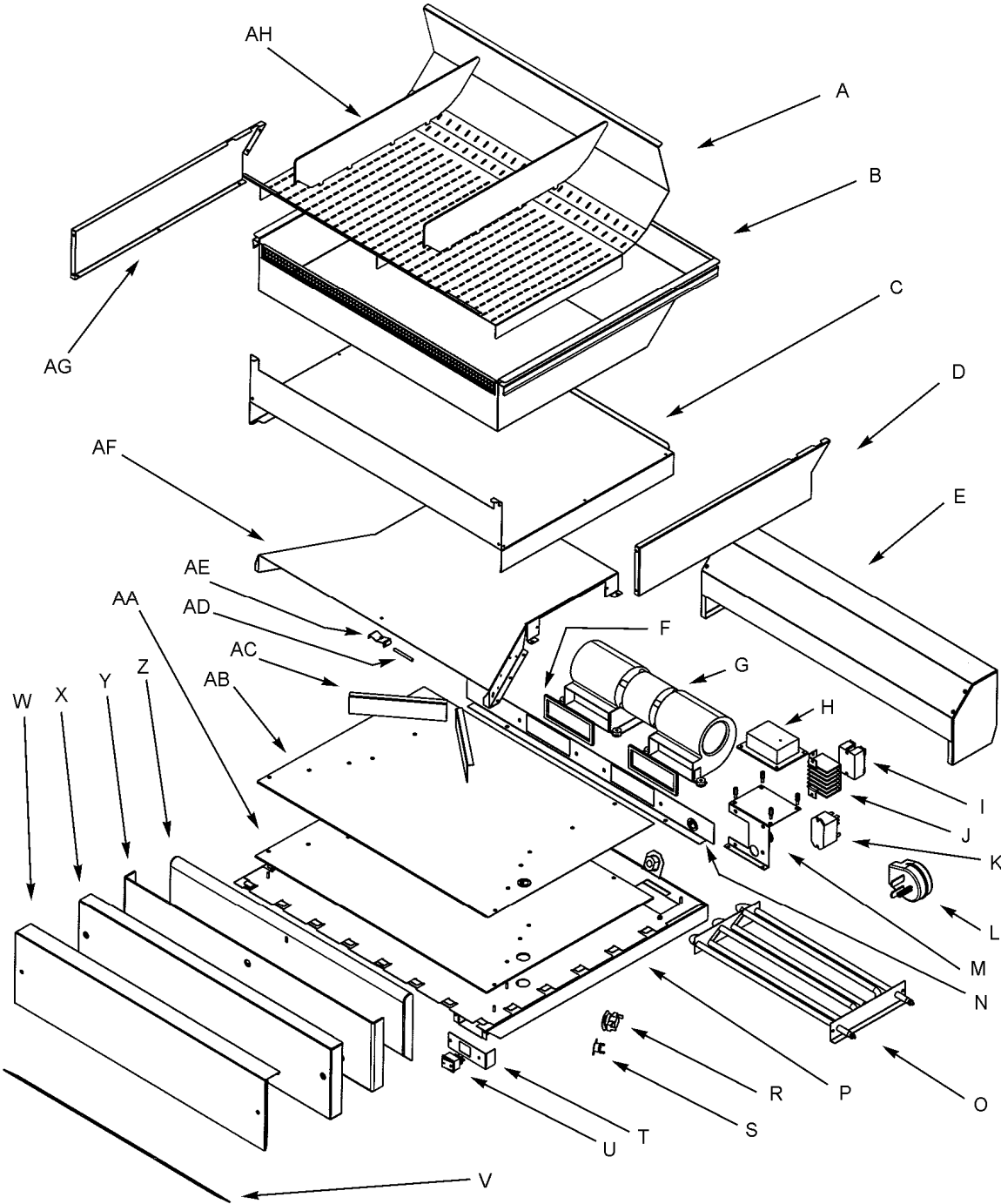

PARTS BREAKDOWN – MODELS 27007, 27012

LETTER	PART #	DESCRIPTION
A	27045-1	Divider Pan
B	27375-4	Tray, Full Pan
C	27370-3	Grease Pan Weldment
D	27080-3	Inner Base, Formed
E	27115-3	Blower Cover Weldment
F	27505	Blower Tangentail
G	27506	Heater, 120V
H	7008349	Filler Air Duct
I	27125	Outer Panel, Right, Formed
J	340095	Power Cord - <i>Model 27007</i>
	340096	Power Cord - <i>Model 27012</i>
K	7008233-3	Bracket, Blower Seal
L	27010-3	Base Cover Weldment
M	27485	Switch, Cool-Down Motor
N	7008236	Plate, Switch Mounting
O	27511	Switch, Rocker, Lighted
P	(see R)	Baffle Air Intake
R	9005266-3	Exhaust Panel Guard, Formed
S	27095-3	Exhaust Panel
T	27035-3	Insulation, Air Scoop
U	27195-3	Air Scoop, Formed
V	27090-3	Insulation, Base, Cut
W	27020-3	Spacer Plate, Insul. Bottom
X	9005267-3	Duct, Air
Y	27120	Outer Panel, Left, Formed

GENERAL VIEW – MODELS 27007, 27012

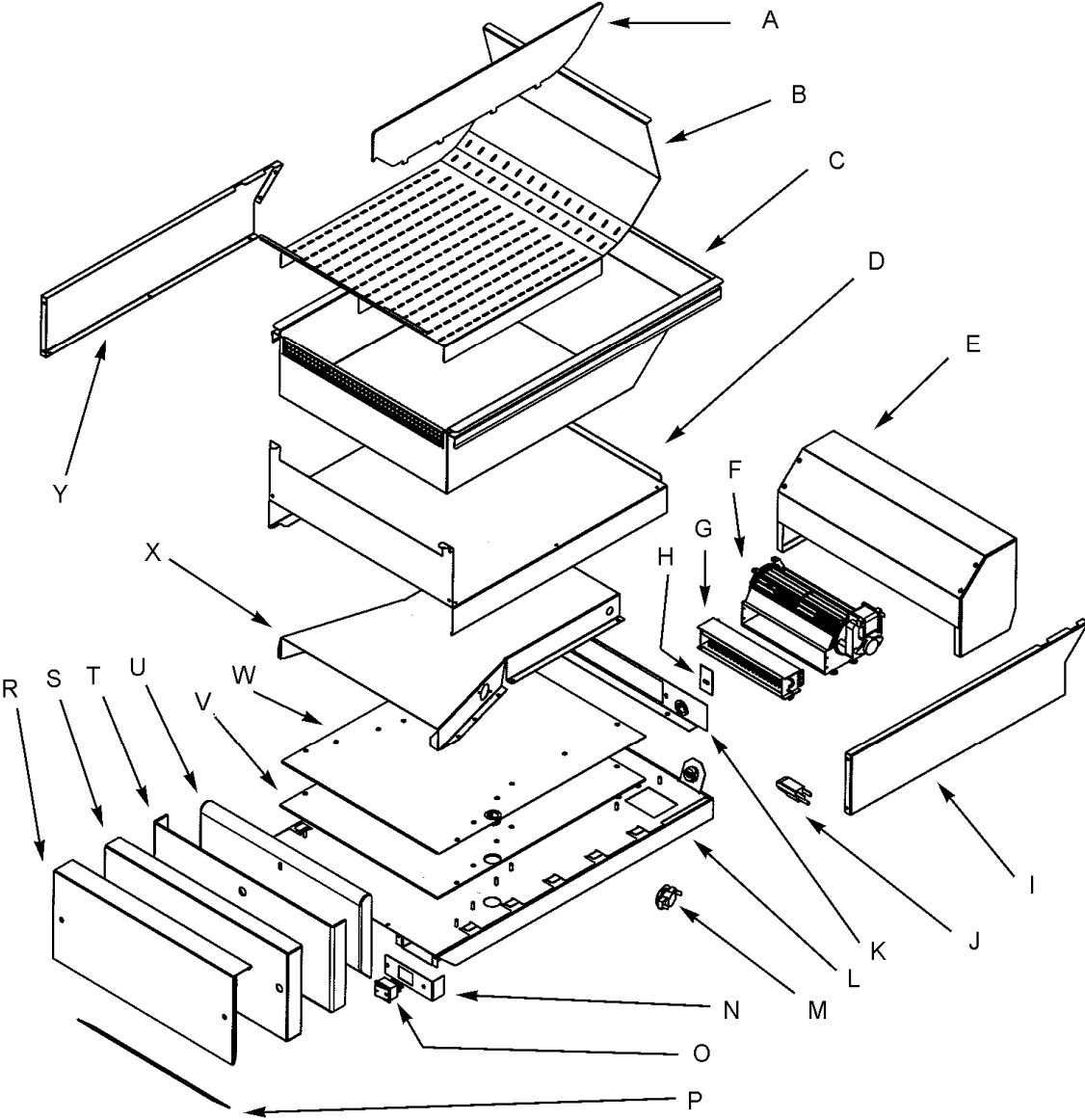

REMOVAL, INSTALLATION AND ADJUSTMENTS

MODELS 27000, 27002



CAUTION:

Disconnect power supply before servicing or cleaning this toaster. Safeguard power so it cannot be accidentally restored. Failure to do so could result in dismemberment, electrocution, or fatal injury.

SWITCH, ON-OFF S/N 1083327 & BELOW

1. Remove the two side grease deflectors from the side panels. Remove the holding tray and the drip pan from the unit well.
2. Remove the two inner side panels. These two panels must be pried from the outside panels at the two notches on the top back side.
3. Fourteen (14) self-tapping screws will now be exposed for removal of the outer panels.
4. Rotate the back motor housing towards the back of the unit to expose the on/off switch.
5. Install new part, reassemble in reverse order, and check operation.

SWITCH, ON-OFF S/N 1083328 & ABOVE

5. Remove two (2) screws from face of switch mounting plate.
6. Disconnect four (4) wires from switch assembly. Mark wires for reinstallation.
7. Depress clips on side of switch and remove switch from panel.
8. Install new part, reassemble in reverse order, and check operation.

SWITCH, COOL-DOWN MOTOR S/N 1083328 & ABOVE

9. Lift and set aside pan tray and grease pan weldment.
10. Remove fourteen (14) screws from both left and right outer formed panels.
11. Lift and set aside blower cover weldment.
12. Remove exhaust panel by sliding forward (toward on/off switch) and set panel aside.
13. Remove inner formed base by sliding forward (toward on/off switch).
14. Disconnect two (2) wires from end of cool-down motor switch. Mark wires for reinstallation.
15. Remove two (2) screws from cool-down motor switch to remove switch.
16. Install new part, reassemble in reverse order, and check operation.

HIGH LIMIT THERMOSTAT S/N 1083327 & BELOW

1. Remove the two side grease deflectors from the side panels. Remove the holding tray and the drip pan from the unit well.
2. Remove the two inner side panels. These two panels must be pried from the outside panels at the two notches on the top back side.
3. Fourteen (14) self-tapping screws will now be exposed for removal of the outer panels.
4. Rotate the back motor housing towards the back of the unit.
5. Remove Inner Base by sliding towards the front of the unit. This piece is held in place by offset tabs. If resistance occurs, bend the two outside front tabs down to allow more clearance.
6. Remove the left and right side Divider Plates from the push on studs.
7. Remove the insulation, the Air Baffle from the push on studs, and the Element Top Panel. The Hi-Limit will be mounted on the side of the Air Baffle.

8. Disconnect two (2) wires from end of high limit thermostat. Mark wires for reinstallation.
9. Remove two (2) screws from the high limit to remove thermostat.
10. Install new part, reassemble in reverse order, and check operation.

HIGH LIMIT THERMOSTAT S/N 1083328 & ABOVE

9. Lift and set aside pan tray and grease pan weldment.
10. Remove fourteen (14) screws from both left and right outer formed panels.
11. Lift and set aside blower cover weldment.
12. Remove exhaust panel by sliding forward (toward on/off switch) and set panel aside.
13. Remove inner formed base by sliding forward (toward on/off switch).
14. Disconnect two (2) wires from end of high limit thermostat. Mark wires for reinstallation.
15. Remove two (2) screws from the high limit to remove thermostat.
16. Install new part, reassemble in reverse order, and check operation.

POWER CORD 250V 30A S/N 1083327 & BELOW

1. Remove the two side grease deflectors from the side panels. Remove the holding tray and the drip pan from the unit well.
2. Remove the two inner side panels. These two panels must be pried from the outside panels at the two notches on the top back side.
3. Fourteen (14) self-tapping screws will now be exposed for removal of the outer panels.
4. Rotate the back motor housing towards the back of the unit to expose the power cord.
5. Install new part, reassemble in reverse order, and check operation.

POWER CORD 250V 30A S/N 1083328 & ABOVE

8. Lift and set aside pan tray and grease pan weldment.
9. Remove fourteen (14) screws from both left and right outer formed panels.
10. Lift and set aside blower cover weldment.
11. Disconnect power cord L1 and L2 wires from wire terminal connections. Mark wires for reinstallation.
12. Remove ground nut from power cord ground wire.
13. Compress cord strain relief to remove power cord from bracket.
14. Install new part, reassemble in reverse order, and check operation.

HEATER 208V, 240V S/N 1083327 & BELOW

1. Remove the two side grease deflectors from the side panels. Remove the holding tray and the drip pan from the unit well.
2. Remove the two inner side panels. These two panels must be pried from the outside panels at the two notches on the top back side.
3. Fourteen (14) self-tapping screws will now be exposed for removal of the outer panels.
4. Rotate the back motor housing towards the back of the unit.
5. Remove Inner Base by sliding towards the front of the unit. This piece is held in place by offset tabs. If resistance occurs, bend the two outside front tabs down to allow more clearance.
6. Remove the left and right side Divider Plates from the push on studs.
7. Remove the insulation, the Air Baffle from the push on studs, and the Element Top Panel. The heating element is under the element top panel.

8. Remove two (2) screws from element bracket.
9. Disconnect two (2) wires from heater and remove heater. Mark wires for reinstallation.
10. Install new part, reassemble in reverse order, and check operation.

HEATER 208V, 240V S/N 1083328 & ABOVE

13. Lift and set aside pan tray and grease pan weldment.
14. Remove fourteen (14) screws from both left and right outer formed panels.
15. Lift and set aside blower cover weldment.
16. Remove exhaust panel by sliding forward (toward on/off switch) and set panel aside.
17. Remove inner formed base by sliding forward (toward on/off switch).
18. Remove two (2) screws from element bracket.
19. Loosen two (2) screws from air duct base next to element bracket for element removal.
20. Disconnect two (2) wires from heater and remove heater. Mark wires for reinstallation.
21. Install new part, reassemble in reverse order, and check operation.

BLOWER S/N 1083327 & BELOW

1. Remove the two side grease deflectors from the side panels. Remove the holding tray and the drip pan from the unit well.
2. Remove the two inner side panels. These two panels must be pried from the outside panels at the two notches on the top back side.
3. Fourteen (14) self-tapping screws will now be exposed for removal of the outer panels.
4. Rotate the back motor housing towards the back of the unit to expose the blower motor.
5. Disconnect three (3) wires from blower. Mark wires for reinstallation.
6. Remove six (6) nuts from base of blower assembly and remove blower assembly.
7. Install new part, reassemble in reverse order, and check operation.

BLOWER S/N 1083328 & ABOVE

9. Lift and set aside pan tray and grease pan weldment.
10. Remove fourteen (14) screws from both left and right outer formed panels.
11. Lift and set aside blower cover weldment.
12. Disconnect three (3) wires from blower. Mark wires for reinstallation.
13. Remove six (6) nuts from base of blower assembly and remove blower assembly.
14. Install new part, reassemble in reverse order, and check operation.

ELECTRONIC TEMPERATURE CONTROL S/N 1083327 & BELOW

1. Remove the two side grease deflectors from the side panels. Remove the holding tray and the drip pan from the unit well.
2. Remove the two inner side panels. These two panels must be pried from the outside panels at the two notches on the top back side.
3. Fourteen (14) self-tapping screws will now be exposed for removal of the outer panels.
4. Rotate the back motor housing towards the back of the unit to expose the temperature control.
5. Disconnect six (6) wires from control board. Mark wires for reinstallation.
6. Remove four (4) nuts from control board and remove control board.
7. Install new part, reassemble in reverse order, and check operation.

ELECTRONIC TEMPERATURE CONTROL S/N 1083328 & ABOVE

1. Lift and set aside pan tray and grease pan weldment.
2. Remove fourteen (14) screws from both left and right outer formed panels.
3. Lift and set aside blower cover weldment.
4. Disconnect six (6) wires from control board. Mark wires for reinstallation.
5. Remove four (4) nuts from control board and remove control board.
6. Install new part, reassemble in reverse order, and check operation.

SOLID STATE RELAY S/N 1083327 & BELOW

1. Remove the two side grease deflectors from the side panels. Remove the holding tray and the drip pan from the unit well.
2. Remove the two inner side panels. These two panels must be pried from the outside panels at the two notches on the top back side.
3. Fourteen (14) self-tapping screws will now be exposed for removal of the outer panels.
4. Rotate the back motor housing towards the back of the unit to expose the solid state relay.
5. Disconnect four (4) wires from relay. Mark wires for reinstallation.
6. Remove two (2) screws from relay and remove solid state relay.
7. Install new part, reassemble in reverse order, and check operation.

SOLID STATE RELAY S/N 1083328 & ABOVE

1. Lift and set aside pan tray and grease pan weldment.
2. Remove fourteen (14) screws from both left and right outer formed panels.
3. Lift and set aside blower cover weldment.
4. Disconnect four (4) wires from relay. Mark wires for reinstallation.
5. Remove two (2) screws from relay and remove solid state relay.
6. Install new part, reassemble in reverse order, and check operation.

POWER RELAY S/N 1083327 & BELOW

1. Remove the two side grease deflectors from the side panels. Remove the holding tray and the drip pan from the unit well.
2. Remove the two inner side panels. These two panels must be pried from the outside panels at the two notches on the top back side.
3. Fourteen (14) self-tapping screws will now be exposed for removal of the outer panels.
4. Rotate the back motor housing towards the back of the unit to expose the solid state relay.
5. Disconnect eleven (11) wires from relay. Mark wires for reinstallation.
6. Remove two (2) screws from relay and remove power relay.
7. Install new part, reassemble in reverse order, and check operation.

POWER RELAY S/N 1083328 & ABOVE

7. Lift and set aside pan tray and grease pan weldment.
8. Remove fourteen (14) screws from both left and right outer formed panels.
9. Lift and set aside blower cover weldment.
10. Disconnect eleven (11) wires from relay. Mark wires for reinstallation.
11. Remove two (2) screws from relay and remove power relay.
12. Install new part, reassemble in reverse order, and check operation.

RTD PROBE S/N 1083327 & BELOW

1. Remove the two side grease deflectors from the side panels. Remove the holding tray and the drip pan from the unit well.
2. Remove the two inner side panels. These two panels must be pried from the outside panels at the two notches on the top back side.
3. Fourteen (14) self-tapping screws will now be exposed for removal of the outer panels.
4. Rotate the back motor housing towards the back of the unit to expose the temperature control board.
5. Remove Inner Base by sliding towards the front of the unit. This piece is held in place by offset tabs. If resistance occurs, bend the two outside front tabs down to allow more clearance.
6. Remove the left and right side Divider Plates from the push on studs.
7. Remove the insulation, the Air Baffle from the push on studs, and the Element Top Panel.
8. Remove the captive screws on the exhaust panel guard.
9. Loosen the RTD probe bracket on the back side of the air scoop panel. The RTD probe runs from this panel through the inner base back to the control board.
10. Disconnect RTD (2) wires from temperature control. Mark wires for reinstallation. Note the path of the wires for reinstallation. Remove RTD probe.
11. Install new part, reassemble in reverse order, and check operation.

RTD PROBE S/N 1083328 & ABOVE

1. Lift and set aside pan tray and grease pan weldment.
2. Remove fourteen (14) screws from both left and right outer formed panels.
3. Lift and set aside blower cover weldment.
4. Remove exhaust panel by sliding forward (toward on/off switch) and set panel aside.
5. Remove inner formed base by sliding forward (toward on/off switch).
6. Tighten RTD holding bracket screw to remove probe.
7. Disconnect RTD (2) wires from temperature control. Mark wires for reinstallation. Note the path of the wires for reinstallation. Remove RTD probe.
8. Install new part, reassemble in reverse order, and check operation.

REMOVAL, INSTALLATION AND ADJUSTMENTS

MODELS 27007, 27012



CAUTION:

Disconnect power supply before servicing or cleaning this toaster. Safeguard power so it cannot be accidentally restored. Failure to do so could result in dismemberment, electrocution, or fatal injury.

SWITCH, ON-OFF

1. Remove two (2) screws from face of switch mounting plate.
2. Disconnect three (3) wires from switch assembly. Mark wires for reinstallation.
3. Depress clips on side of switch and remove switch from panel.
4. Install new part, reassemble in reverse order, and check operation.

SWITCH, COOL-DOWN MOTOR

1. Lift and set aside pan tray and grease pan weldment.
2. Remove fourteen (14) screws from both left and right outer formed panels.
3. Lift and set aside blower cover weldment.
4. Remove six (6) screws from air intake baffle.
5. Remove two (2) screws from bottom of exhaust panel and set panel aside.
6. Remove inner formed base by sliding forward (toward on/off switch).
7. Disconnect two (2) wires from end of cool-down motor switch. Mark wires for reinstallation.
8. Remove two (2) screws from cool-down motor switch to remove switch.
9. Install new part, reassemble in reverse order, and check operation.

POWER CORD 120V

1. Lift and set aside pan tray and grease pan weldment.
2. Remove fourteen (14) screws from both left and right outer formed panels.
3. Lift and set aside blower cover weldment.
4. Disconnect power cord neutral and L1 wires from in-line wire terminal connections. Mark wires for reinstallation.
5. Remove ground nut from power cord ground wire.
6. Compress cord strain relief to remove power cord from bracket.
7. Install new part, reassemble in reverse order, and check operation.

HEATER 120V

1. Lift and set aside pan tray and grease pan weldment.
2. Remove fourteen (14) screws from both left and right outer formed panels.
3. Lift and set aside blower cover weldment.
4. Remove six (6) screws from air intake baffle.
5. Remove two (2) screws from bottom of exhaust panel and set panel aside.
6. Remove inner formed base by sliding forward (toward on/off switch).
7. Remove three (3) screws from base of blower assembly.
8. Remove two (2) screws from both left and right air duct fillers.
9. Slide out blower and heater assembly from blower seal bracket.
22. Remove four (4) screws from side of heater to separate heater from blower.

23. Disconnect two (2) wires from heater and remove heater. Mark wires for reinstallation. Note the path of the wires for reinstallation.
24. Install new part, reassemble in reverse order, and check operation.

BLOWER

1. Lift and set aside pan tray and grease pan weldment.
2. Remove fourteen (14) screws from both left and right outer formed panels.
3. Lift and set aside blower cover weldment.
4. Disconnect two (2) wires from blower. Mark wires for reinstallation.
5. Remove three (3) screws from base of blower assembly.
6. Remove two (2) screws from both left and right air duct fillers.
15. Slide out blower and heater assembly from blower seal bracket.
16. Remove four (4) screws from side of heater to separate heater from blower.
17. Install new part, reassemble in reverse order, and check operation.

This page intentionally left blank.

This page intentionally left blank.

This page intentionally left blank.



Merco Savory, LLC
1111 North Hadley Road
Fort Wayne, Indiana 46804
United States of America

Telephone: (260) 459-8200
U.S. Facsimile: (888) 790-8193
Int'l Facsimile: (260) 436-0735

Technical Support Hotline: (800) 678-9511

www.mercosavory.com

