

SERVICE MANUAL

(INTERNATIONAL)

IMPINGER CONVEYOR OVENS

MODEL 1633-000-EA, 1634-000-EA

WITH PUSH BUTTON CONTROLS



Lincoln Foodservice Products, LLC
1111 North Hadley Road
Fort Wayne, Indiana 46804
United States of America

Phone: (800) 374-3004
U.S. Fax: (888) 790-8193 • Int'l Fax: (260) 436-0735

Technical Service Hot Line
(800) 678-9511

www.lincolnfp.com



**SEQUENCE OF OPERATIONS
SERIAL NUMBERS L28563 AND ABOVE
(WITH PUSH BUTTON CONTROL)**

MODEL 1633-000-EA 230 VAC 50HZ NATURAL GAS
MODEL 1634-000-EA 230 VAC 50HZ LP GAS

POWER SUPPLY	<p>Electrical power to be supplied to the oven by a three conductor service.</p> <p>Brown conductor is hot Blue conductor is neutral. Green conductor is ground.</p>
CONTROL BOX AUTO COOL DOWN	<p>When the temperature in either one of the control boxes reaches 120°F ±3° (49°C ± 1.7°), the cooling fan thermostats will switch power to the cooling fans. The thermostats will interrupt power to the cooling fans when the temperature falls to 100°F ± 3° (37°C ± 1.7°)</p>
MAIN FAN CIRCUIT	<p>Line voltage is permanently supplied to a normally open contact of the oven power switch. Line voltage is permanently supplied to the two normally open cooling fan thermostats, a normally open contact of the oven power relay. Closing the oven power switch supplies line voltage, through both normally closed control box hi-limit thermostats, to the oven power relay. Its contacts now close supplying line voltage to the two main fan motors and the two burner circuits. Closing the oven power switch also supplies line voltage to the control box cooling fans, the control transformer, and the conveyor motor.</p>
BURNER CIRCUIT	<p>NOTE: This oven utilizes two complete burner systems. The sequence of operations is the same for each system.</p> <p>Closing the main fan switch supplies line voltage, through the oven power relay, through a three Amp.fuse, through the gas pressure switch (gas pressure switch removed at S/N L31479), through the main fan air pressure switch, through the oven cavity hi-limit thermostat, to the ignition control. The combustion motor is energized. The normally open combustion air switch closes upon sensing air pressure. After a pre-purge period of between 30 and 60 seconds, the ignition transformer and the main gas valve are energized. Ignition should now occur.</p>
TEMPERATURE CONTROL	<p>Closing the oven power switch supplies line voltage, through the 10 amp. fuse, through the oven power relay, to the primary of the control transformer. 24VAC is supplied to the oven control. The oven control is set to desired temperature. The thermocouple will provide varying millivolts to the oven control. The oven control supplies line voltage to the temperature regulation valve at intermittent intervals to maintain desired temperature. The display on the oven control will indicate when the temperature regulation valve is energized.</p> <p>NOTE: The display also indicates oven temperature.</p>
CONVEYOR DRIVE	<p>Closing the oven power switch supplies line voltage, through the 10 Amp fuse, through the oven power relay to the conveyor motor and to the primary of the control transformer. Secondary voltage, 24VAC, is supplied to the oven control. Setting the oven control to the desired time outputs voltage, through a reversing switch, to the conveyor motor</p> <p>NOTE: The conveyor system uses a magnet and hall effect sensor to prove operation of the conveyor motor. If the conveyor motor is not running, "BELT JAM" is indicated on the display.</p>

TROUBLESHOOTING GUIDE

MODEL 1633-000 EA NATURAL GAS 230 VAC 50 HZ 1 PHASE
 MODEL 1634-000-EA LP GAS 230 VAC 50 HZ 1 PHASE

NOTE: When checking components on left side of unit, be sure to check for proper connections in power connector, (marked P. C. on schematic diagram) located inside motor cover.

SYMPTOM	POSSIBLE CAUSE	EVALUATION
Oven fan will not run	Incoming power supply	Check breakers/ reset if required call Power company if needed
	Oven fan switch	Check continuity between switch terminals.
	Hi-limit thermostat(s), control box	Terminals are normally closed, if open, reset thermostat and test oven for proper operation. If it will not reset, replace thermostat.
	Fan fuse	Check, replace if necessary.
	Fuseholder	Check, replace if necessary.
	Oven fan relay	Check for power to coil of oven fan relay. If no voltage is present, trace wiring back to hi-limit thermostat. Check for supply voltage at terminal #6 of the relay. If no voltage is present, trace wiring back to fuse holder. If voltage is present, at the relay coil, check to insure the contacts are closing.
	Capacitor(s)	Check for opens, shorts, or grounds.
	Motor(s), main fan	Check for opens, shorts, or grounds.
No control box cooling	Fan switch	(SEE OVEN FAN WILL NOT RUN.)
	Hi-limit thermostat(s)	
	Oven fan relay	
	Cooling fan(s)	Supply voltage should now be at these motors. If voltage is present, check motor for open, shorts, or grounds. WITH POWER OFF: check for locked rotor.
No automatic control box cooling	Incoming power supply	Check circuit breakers, reset if needed. Call power company if needed.
	Cooling fan thermostat(s)	Check the cooling fan thermostat. (thermostat closes at 120°F and opens at 100°F). With the cooling fan thermostat preheated, check for continuity. If switch is open, replace.
	Cooling fan(s)	Supply voltage should now be at these motors. If voltage is present, check motor for opens, shorts or grounds. WITH POWER OFF: Check for locked rotor.
Oven will not heat	Gas supply	Check for adequate gas supply to oven.
	Manual gas shut off valve	Check to see that the manual gas shut off valve is open. Also check flexible gas line connection for any damage.
	Fan switch	Check to see that the fan switch is on.
	Main oven fan	Check if main oven fan is operating. If not, refer to "Oven fan will not run".
NOTE: These ovens utilize 2 complete Burner/Temperature control systems. Each system will Follow the same troubleshooting sequence.		
	Oven power relay	Check for line voltage to the relay coil. If no voltage is present, trace wiring back to the control box hi-limit thermostat(s). If voltage is present, check to insure contacts are closing. Replace relay as needed.
Serial Number L31478 & Below	Fuse, burner 3A.	Check, replace if necessary.
	Fuseholder	Check, replace if necessary.

Gas pressure switch (internal to gas valve)	Check for supply voltage to neutral on both sides of switch. If voltage is present on one side of switch only, check the following. Check for proper gas pressure supply to gas valve.(Marked on oven spec. plate.) Check for proper adjustment of gas pressure switch, should be set at 10 for Nat., 27 for LP, or 4.5 for town gas. Check gas filter in gas valve for blockage or damage. (See Adjustment section for location.) If the above checks OK, but switch is still not closed replace gas valve.
Oven air pressure switch	Check for supply voltage on both sides of switch. If voltage is present on one side only, check for air tube blockage. Adjust air pressure switch. If the above fails, replace air pressure switch.
Hi-limit thermostat	Terminals are normally closed. If open, reset and test oven for proper operation. If thermostat will not hold for maximum oven temperature, and oven is not exceeding maximum temperature dial setting, check for proper location of capillary bulb in its spring holder. If above checks OK, replace hi-limit.
Ignition control	Check for supply voltage to ignition control at terminal #1 and neutral. If voltage is not present, trace wiring back to hi-limit thermostat. Check for supply voltage at terminal #6 to neutral. If no voltage is present, wait 30 seconds and check reset button. If above fails, replace ignition control.
Burner reset switch	Switch is normally open. Check to see that the switch closes when reset button is pushed. Replace as needed.
Burner blower motor	Check for supply voltage to burner blower motor. WITH POWER OFF: Turn blower wheel to check for locked rotor. If supply voltage is present and motor does not run, replace motor.
Burner blower motor Air pressure switch	Check for supply voltage switching to terminal N.O. as the air pressure switch closes. Check for air tube blockage or misalignment, adjust air pressure switch. If the above fails, replace air pressure switch.
Spark generator	After a pre-purge time of 30 to 60 seconds after blower motor starts, check for supply voltage to spark generator. If voltage is not present, Check reset button located on rear of control box. If voltage is still not present, replace ignition control. If voltage is present, visually check for spark at igniter head.
Igniter/sensor assembly	Check for visible damage to igniter/ sensor assembly. If there is no visible damage to the components, and no spark, replace the spark generator. If there is visible damage to the igniter/sensor assembly, replace. Also check for frayed or damaged wires in burner tube.
Gas valve	Check for supply voltage to gas valve. If there is no voltage present, check reset button, check all connections for tightness. If there still is no voltage at gas valve, replace ignition control. If there is voltage present, check for gas pressure at gas pressure tap located in gas piping at burner manifold. If there is no gas pressure, replace gas valve.

Flame will not stay on	Flame sensor	To check for flame sensor operation, connect a digital multimeter (capable of measuring D.C. micro amps) in series with the flame sensor wire and ignition control. Sensor current is 3 micro amps D.C. minimum. NOTE: The D.C. micro amp test must be conducted with the oven in low flame (bypass) operation. Turn the temperature control to its lowest setting. If these readings are not achieved, replace igniter/sensor assy. Also, check for any type of damage to flame sensor wire and connections.
	Ignition control	If there is sufficient flame sensor current, but the burner will not remain ignited, check the reset button on ignition control. NOTE: Check for proper polarity of the power supply. If all of the above are OK, replace ignition control.
Oven will not heat Serial Number L31479 and above	Oven power relay	Check for line voltage to the relay coil. If no voltage is present, trace wiring back to the control box hi-limit thermostat(s). If voltage is present, check to insure contacts are closing. Replace relay as needed.
	Fuse, burner, 3A	Check, replace if necessary.
	Fuse holder	Check, replace if necessary.
	Air pressure switch	Check air switch terminals for supply voltage to terminals C and NO. If voltage is present on one side only, check for air tube blockage or misalignment. If these check okay, adjust air pressure switch, or replace air pressure switch as needed.
	Oven cavity hi-limit thermostat	Terminals are normally closed, opens at 350°C (660°F). If open, reset and test oven for proper operation. If thermostat will not hold for maximum oven temperature, and oven is not exceeding control setting, check for proper location of capillary bulb in its spring holder. If above checks are okay, replace hi-limit thermostat.
	Ignition control	Check for proper supply voltage to ignition control. Check for proper voltage to the burner blower motor. This can be checked at motor connecting plug terminal 5 and Neutral. If voltage is present, proceed with next test, if not, wait 30 seconds, push reset button and try to restart. If this fails, check wires from burner blower motor to the ignition control. If the above checks okay, replace ignition control.
	Burner blower motor	Check for supply voltage to motor. WITH POWER OFF: Turn blower wheel to check for locked rotor. If supply voltage is present at motor connecting plug terminal 5 and Neutral, and motor does not run, replace burner blower motor.
	Air pressure switch (burner motor)	Check for proper supply voltage switching from "NC" to "NO" on the air pressure switch. Check for air pressure switch adjustment, air tube blockage or misalignment. If these adjustments fail, replace air pressure switch.
	Ignition control	A pre-purge time of 30 to 60 seconds occurs after burner blower motor starts. Check for high voltage spark output from the ignition control. If there is no high voltage spark output, check reset button for ignition control. If there is still no high voltage output, replace the ignition control.

	Igniter/sensor assembly	Check this assembly for visible damage. Replace as needed. If there is no visible damage, check for voltage supply to igniter/sensor assembly. If there is voltage supplied to the igniter/sensor, but there is no spark, replace the igniter/sensor assembly.
	Gas valve	Gas valve should open as the ignition control generates the high voltage spark. Place a manometer on the pressure tap fitting (located in the gas piping just prior to the burner manifold) and check for gas pressure. If valve does not open, check reset button on ignition control, and all connections for tightness. If there is still no gas pressure, remove the ignition control from the gas valve. Check the coils of the gas valve for opens or shorts. Readings should be as follows: V1 – 2.9K ohms approx., V2 – 1.3K ohms approx. If these readings are not achieved, replace gas valve. If these readings are achieved, replace ignition control.
Flame will not stay on	Flame sensor	To check for flame sensor operation, connect a digital multimeter (capable of measuring D.C. microamps) between the flame sensor wire and the flame sensor connection on the ignition control. Sensor current is to be 0.9 microamps, minimum. If these readings are not achieved, replace the igniter/sensor assembly. Also check for any type of damage to the flame sensor wire and connections. NOTE: The D.C. microamp test must be conducted with the oven in low flame (bypass) operation
	Power supply	Set the temperature to the lowest temperature setting. If there is sufficient microamp current, but the flame will not stay lit, check for proper polarity of the power supply.
	Ignition control	If there is sufficient microamp current, and there is proper polarity of the power supply, but the burner will not stay lit, check the reset button for the ignition control. If the above test is okay, replace ignition control.
	NOTE: Flame should be on at this time	
Low flame is on, But no main flame	Control transformer	Check for supply voltage to the primary of the control transformer. If no voltage is present, trace wiring back to the oven power relay. If primary voltage is present, check for 24VAC at the transformer secondary. If there is primary voltage, but no secondary voltage, replace control transformer.

	Oven control	<p>Check for 24VAC supply to control. If no voltage is present, trace wiring back to control transformer. If 24VAC is present, check for a read-out on the control display. If there is 24VAC supplied, but there is no read-out on the control display, replace the oven control.</p> <p>If there is a read-out on the control, set the control to maximum temperature (see installation operations manual for temperature adjustment). With the control set at maximum temperature, check for line voltage at the temperature regulation valve. If there is voltage at the temperature regulation valve, proceed to “temperature regulation valve” for next check. If there is no voltage at the temperature regulation valve, trace wiring back to the oven control. If there is no voltage output at the oven control, check the read-out on the control. If the control reads “LP FAIL” or “RP FAIL”, this indicates that the thermocouple has failed or has become disconnected from the control. “LP FAIL” indicates a problem with the left thermocouple probe, and “RP FAIL” indicates a problem with the right thermocouple probe.</p>
	Thermocouple probe	<p>Check to be sure that the thermocouple is securely connected to the oven control. If the thermocouple is connected to the oven control, and the control indicates “LP FAIL” or “RP FAIL”, disconnect the thermocouple from the oven control and measure the resistance of the thermocouple. The left thermocouple should read approx. 21Ω. The right thermocouple should read approx. 11Ω. If these readings are not achieved, replace the thermocouple. If these readings are correct, proceed.</p>
	Oven control	<p>If the thermocouple checks good, but the oven control display indicates that there is a thermocouple failure, replace the oven control. If the oven control indicates a temperature reading but the oven will not heat, proceed.</p>
	Thermocouple	<p>WITH POWER ON AND THERMOCOUPLE ATTACHED TO THE OVEN CONTROL: Measure the DC millivolt output of the thermocouple. Refer to the thermocouple chart (located in the “Removal” section of the manual) for proper millivolt readings. If these readings are not achieved, replace thermocouple.</p>
	Oven control	<p>If the thermocouple checks good, but there is no voltage output to the temperature regulation valve, replace the oven control. If there is voltage output to the temperature regulation valve, proceed.</p>
	Temperature regulation valve	<p>Check for line voltage supplied to the temperature regulation valve. If no voltage is present, trace wiring back to the oven control. If voltage is present, listen for the valve to open and close. Also check for opens or shorts in the operating coil. Replace temperature regulation valve as needed.</p>

Intermittent heating	Thermal overload of main fan and burner blower motors	The main fan motors and the burner blower motors are equipped with internal thermal protection and will cease to operate if overheating occurs. As the motors overheat and then cool, this will cause the units to cycle on and off intermittently. Improper ventilation or lack of preventive maintenance may cause this problem. Also, most of the problems listed under "Oven will not heat" can cause intermittent failure.
Conveyor will not run	Power supply	Check for supply voltage at terminals L1 and L2. If voltage is not present check breakers.
	Power switch	Check continuity between switch terminals. Replace switch as needed.
	Fuse, 10 Amp.	Check and/or replace.
	Fuse holder	Check and/or replace.
	Hi-limit thermostat(s), control box	Check for voltage on both sides of the switch. Terminals are normally closed. If open, reset and test for proper operation. If thermostat will not hold, and the control box temperature is not exceeding 140°F (60°C), replace thermostat.
	Relay, oven power	Check for line voltage to the relay coil. If voltage is not present, trace wiring back to the hi-limit thermostat. If voltage is present, check to insure contacts are closing. Replace relay as needed.
	Control transformer	Check for line voltage supply to the primary of the control transformer. If no voltage is present, trace wiring back to the oven power relay. If voltage is present, check for 24VAC at the transformer secondary. If there is primary voltage, but no secondary voltage, replace control transformer.
	Conveyor motor	Check for line voltage supply to the conveyor motor at wire #28 to neutral. If no voltage is present, trace wiring back to the oven power relay. If voltage is present and the motor will not run, check the motor windings for opens or shorts. WITH POWER OFF: Check the motor windings as follows: Grey to black - 116Ω Grey to brown - 116Ω Brown to black - 230Ω
	Capacitor, conveyor motor	Check for shorts or grounds. Replace capacitor as needed. WARNING: Capacitor has a stored charge, discharge before testing.
	Switch, conveyor reversing	Check continuity between switch terminals, Replace switch as needed.
	Oven control	If there is supply voltage to the motor. And the motor, capacitor, and reversing switch check good, replace the oven control.
Conveyor motor runs, but there is no speed display	NOTE: Display will indicate "Belt jam"	
	Oven control	Check for output voltage from the oven control to hall effect sensor (sensor is located in conveyor motor). Measure voltage at the motor connector, red wire and yellow wire. Voltage should be approx. 10VDC. If no voltage is present, trace wiring back to oven control. If there is no voltage present at the oven control, replace the oven control.

	Conveyor motor	If there is voltage supplied to the hall effect sensor, check for a frequency output from the hall effect sensor. Measure frequency across the yellow and white wires at the motor connector. Frequency readings should be approx. 25 – 100 Hz. If these readings are not achieved, replace the conveyor motor. If the readings are achieved, proceed.
	Oven control	If the hall effect sensor readings are correct, but there is no speed indicated on the display, replace the oven control.

REMOVAL, INSTALLATION & ADJUSTMENTS

MODEL SERIES 1633-000-EA, 1634-000-EA
SERIAL NUMBER L28563 AND ABOVE
OVEN WITH PUSH BUTTON CONTROLS

CAUTION!

BEFORE REMOVING OR INSTALLING ANY COMPONENT IN THE IMPINGER OVEN BE SURE TO DISCONNECT ELECTRICAL POWER AND GAS SUPPLY.

IGNITION CONTROL – REPLACEMENT (S/N L31478 and Below)

- A. Remove appropriate control box cover.
- B. Remove front portion of relay by releasing tabs on side pulling straight out (rocking motion).
- C. Remove wires from plug-in terminal strip, note wire numbers and location.
- D. Remove two screws from mounting bracket and remove.
- E. Reassemble in reverse order. Check system operation.

IGNITION CONTROL – REPLACEMENT (S/N L31479 and Above)

- A. Remove appropriate control box cover.
- B. Remove wires from control and mark for reassembly.
- C. Remove one mounting screw and remove ignition control from gas valve.
- D. Reassemble in reverse order and check system operation.

BURNER BLOWER MOTOR – REPLACEMENT

- A. Remove appropriate control box cover.
 - B. Unplug motor connector.
 - C. Remove three screws from blower tube at burner housing.
 - D. Remove air shutter assy. From old motor for installation on new motor assy.
 - E. Reassemble in reverse order and check system operation
- NOTE: CHECK AIR SHUTTER ADJUSTMENT – should be set at ½ open.

AIR PRESSURE SWITCH – REPLACEMENT

- A. Remove control panel top.
- B. Disconnect wires from switch making note of wire number and location for reinstallation.
- C. Remove air tube from switch assembly.
- D. Remove switch from wire hanger.
- E. Install new switch in reverse, make sure air tube is not blocked or misaligned.

To adjust air pressure switch, remove cover from the switch to expose adjusting screw. To increase sensitivity, turn screw counter-clockwise; to decrease sensitivity, turn screw clockwise. Check for proper line voltage switching from N.C. to N.O. as the air pressure switch closes.

CONVEYOR DRIVE MOTOR – REPLACEMENT

- A. Shut off power at main breaker.
- B. Remove conveyor.
- C. Remove control panel top and front cover.
- D. Disconnect wiring from motor and mark for reassembly.
- E. Remove sprocket from motor shaft.
- F. Remove 4 screws and remove conveyor motor and mounting bracket.
- G. Remove mounting bracket from conveyor motor assembly.
- H. Reassemble in reverse order.

CAPACITOR, CONVEYOR MOTOR – REPLACEMENT

- A. Shut off power at main breaker.
- B. Remove control box cover and front panel.
- C. Discharge capacitor before removing wires. Mark wires for reassembly.
- D. Remove mounting screw and remove capacitor.
- E. Reassemble in reverse order.

REVERSING SWITCH – REPLACEMENT

- A. Shut off power at main breaker.
- B. Disconnect wiring from reversing switch and mark for reassembly.
- C. Remove mounting nut and remove reversing switch.
- D. Reassemble in reverse order and check system operation.

REVERSING CONVEYOR DIRECTION

- A. Shut off power at oven switch.
- B. Set reversing switch in the other position.
- C. Turn oven “on” and check for proper operation.

FUSEHOLDER – REPLACEMENT

- A. Remove appropriate control box cover.
- B. Remove 2 wires, note wire number and location.
- C. Remove locknut on backside of fuse holder and push out.
- D. Reinstall in reverse order and check system operation.

GAS VALVE – REPLACEMENT AND ADJUSTMENT (S/N L31478 and Below)

- A. Remove appropriate control box cover.
- B. Disconnect the gas piping from the back of the unit.
- C. Remove the 4 screws from the incoming nipple mounting bracket.
- D. Remove incoming nipple.
- E. Disconnect 2 plugs (1) 3prong and (1) 4 prong – note location.
- F. Disconnect pipe union just above gas valve and remove assembly.
- G. Reassemble in reverse order (check all pipe fittings for leaks). After assembled check for proper adjustment of gas pressure switch, 10on dial for natural gas, 27 for LP gas, and 4.5 for town gas.
- H. Check and adjust manifold pressure. Remove pressure tap located in gas piping above the gas valve prior to the burner orifice and install manometer. Adjustment screw is located on the front of the valve, remove plastic cap and adjust as needed: 3.5” W.C. for natural gas, 10” W.C. for LP and 2.0” W.C. for town gas.
- I. Check gas filter by removing cover plate (located on either side of valve). Remove 4 screws and slide filter out of valve housing and inspect. Reassemble in reverse order and check for leaks around cover.

GAS VALVE – REPLACEMENT (S/N L32479 and Above)

- A. Remove appropriate control box cover.
- B. Disconnect the gas piping from the back of the unit.
- C. Remove the 4 screws from the incoming nipple mounting bracket.
- D. Remove incoming nipple.
- E. Remove wiring from ignition control (mounted on gas valve) mark all wiring for reassembly.
- F. Remove pilot tube. Disconnect pipe union in gas line and remove gas valve and piping assembly.
- G. Remove piping from gas valve. Reassemble in reverse order and check system operation.
- H. Check all gas line fittings for leaks.
- I. Adjust the gas manifold pressure on the gas valve. Refer to the specification plate on the oven for proper rating.

BURNER ALARM - REPLACEMENT

- A. Remove appropriate control box cover.
- B. Remove 2 wires from alarm, note wire numbers and location.
- C. Remove retainer cover from alarm and remove assembly from control box.
- D. Reassemble in reverse order and check system operation.

SPARK GENERATOR – REPLACEMENT

- A. Remove appropriate control box cover.
- B. Remove 2 wires for spark generator.
- C. Unplug connector on bottom of spark generator.
- D. Remove 2 mounting screws and remove generator assembly.
- E. Reassemble in reverse order and check system operation.

IGNITER SENSOR – REPLACEMENT

- A. Remove appropriate control box cover.
 - B. Remove gas valve assembly (see gas valve)
 - C. Remove screws from burner tube and pull burner assembly out.
 - D. Remove wire connectors from igniter sensor assembly.
 - E. Remove screws from mounting bracket and remove assembly.
 - F. Reassemble in reverse order and check system operation.
- NOTE: After installation, check all pipe fittings for leaks.

SWITCH, BURNER RESET – REPLACEMENT

- A. Remove appropriate control box cover.
- B. Disconnect wires from ignition control (see ignition control). Note wire number and location for reassembly.
- C. Pull off black operating knob and remove hex mounting nut.
- D. Reassemble in reverse order.

TEMPERATURE REGULATING VALVE – REPLACEMENT

- A. Remove appropriate control box cover.
- B. Remove bypass tube assembly.
- C. Remove 4 nuts from burner orifice bracket.
- D. Disconnect pipe union.
- E. Disconnect 2 wires from valve and remove assembly.
- F. Remove gas piping from old valve and install on new valve.
- G. Reassemble in reverse order and check system operation. NOTE: Check all gas line fittings for leaks and insure valve gas flow is in proper direction.

MAIN ORIFICE – REPLACEMENT

- A. Remove appropriate control box cover.
 - B. Remove bypass tube assembly.
 - C. Remove 4 nuts from burner orifice bracket.
 - D. Disconnect pipe union.
 - E. Remove assembly and replace main orifice.
 - F. Reassemble in reverse order and check system operation.
- NOTE: Check all gas line fittings for leaks.

BYPASS ORIFICE – REPLACEMENT

- A. Shut off power at main breaker.
- B. Remove appropriate control box cover.
- C. Remove pilot tube from bypass orifice and remove orifice.
- D. Reassemble in reverse order and check system operation. Check all gas connections for leaks.

THERMOSTAT, HIGH LIMIT, OVEN CAVITY – REPLACEMENT

- A. Remove appropriate control box cover. Remove motor cover and remove oven back to access high limit thermostat.
- B. Remove wires from thermostat, note wire numbers for reinstallation.
- C. Remove mounting nut from high limit thermostat and remove high limit from oven.
- D. Reassemble in reverse order. Check system operation.

ON-OFF SWITCH (POWER) – REPLACEMENT

- A. Remove control box cover.
 - B. Depress spring clips on side of switch and push out.
 - C. Remove wires from back of switch, note wire number and location.
 - D. Reassemble in reverse order and check system operation.
- NOTE: Make sure switch housing is fully seated in control box housing.

CAPACITOR, MAIN FAN MOTOR – REPLACEMENT

- A. Remove appropriate control box cover.
- B. Remove 2 wires from capacitor, note wire number and location. **WARNING:** Capacitor has a stored charge, discharge before handling or testing.
- C. Cut 2 tyraps securing capacitor to base and replace.
- D. Reinstall in reverse order and check system operation.

RELAY – REPLACEMENT

- A. Remove control box cover.
- B. Remove wires from relay, note wire numbers and location for reinstallation.
- C. Remove 2 screws from relay base and replace relay.
- D. Reassemble in reverse order making sure wire connections are properly seated.
- E. Check system operation.

THERMOSTAT, COOLING FAN – REPLACEMENT

- A. Remove appropriate control box cover.
- B. Remove 2 wires from thermostat, note wire number and location.
- C. Remove 2 mounting screws and replace thermostat.
- D. Reassemble in reverse order and check system operation.

HIGH LIMIT THERMOSTAT – REPLACEMENT

- A. Remove appropriate control box cover.
 - B. Remove 2 wires from thermostat, note wire numbers and location for reinstallation
 - C. Remove screws from bracket and remove thermostat.
 - D. Reassemble in reverse order and check system operation.
- NOTE: Depress reset button to insure thermostat is set for operation.

COOLING FAN MOTOR – REPLACEMENT

- A. Remove appropriate control box cover.
- B. Remove 4 mounting screws.
- C. Unplug electrical connector and remove fan motor.
- D. Reassemble in reverse order and check system operation.

MAIN FAN MOTOR – REPLACEMENT

- A. Shut off gas supply and remove gas line and manifold lines from back of oven.
 - B. Remove screws from motor cover housing and lift off.
- NOTE: When ovens are stacked, all motor cover housings are fastened together.
- C. Unplug power connector.

- D. Unplug thermocouple.
- E. Unplug 2 motor connectors.
- F. Remove 8 bolts from oven back (4 left, 4 right) and lift out.
- G. Remove 1 screw from fan hub and slide fan blade off of motor shaft. (note location of fan blade for reinstallation)
- H. Loosen locknuts on cone. Remove 2 mounting bolts and remove motor from back assembly.
- I. Remove 4 hex head screws from motor mount bracket. Remove motor mount from motor and reinstall on new motor.
- J. Reassemble in reverse order. NOTE: 1. Make sure motor is centered in back housing.
2. Verify correct location of fan blade and that it is not hitting fan shroud.
3. Make sure all connectors are properly seated and making good contact.
4. When reinstalling gas manifold across back of oven, check all fittings for leaks.
- K. Check system operation (allow 30 minute preheat for all checks) NOTE: Position of the fan on the motor shaft will be 1.875" from the top of the oven back cone to the blade spider assembly on the fan hub. (see drawing below).

THERMOCOUPLE (TYPE K) – REPLACEMENT

- A. Remove control box covers. Remove motor cover and remove oven back to access thermocouple.
NOTE: Removal of oven back assy. Is required to replace thermocouples.
- B. Remove thermocouple from wire form in oven chamber and remove from chamber.
NOTE: R. H. thermocouple (viewed from front) is connected directly to the temperature control board, remove 2 wires , make note of wire colors and location. When changing L. H. thermocouple (viewed from front, the back motor cover must also be removed to gain access to the thermocouple connector plug.)
- C. Reassemble in reverse order making sure bulb is placed securely in the wire form in the oven chamber.
- D. Check system operation, recalibrate as needed. NOTE: The R. H. and L. H. thermocouples have different connectors on the wire ends and must be ordered accordingly.

THERMOCOUPLE MEASUREMENT

TEMPERATURE (°F)	D.C. MILLIVOLTS
200°	2.8
250°	4.0
300°	5.1
350°	6.0
400°	7.1
450°	8.2
500°	9.3
550°	10.4
600°	11.5

BEARING, CONVEYOR – REPLACEMENT

- A. Remove conveyor from oven and place on a flat work surface.
- B. Remove connecting links from conveyor belting. See Installation and Operating Instructions Manual.
- C. Remove conveyor belting from conveyor. Remove drive sprocket from drive shaft.
- D. Move drive shaft or idle shaft toward end of conveyor, and shaft with bearings will now slip out of holding bracket.
- E. Replace bearing and reassemble in reverse order.

CONTROL TRANSFORMER – REPLACEMENT

- A. Shut off power at main breaker.
- B. Remove wires from primary side, note color and location.
- C. Remove wires from secondary side, note color and location.
- D. Remove two mounting screws and remove transformer.
- E. Reassemble in reverse order and check system operation.

OVEN CONTROL – REPLACEMENT

- A. Shut off power at main breaker.
- B. Remove control box cover and front panel.
- C. Remove all wiring connections and mark for reassembly.
- D. Remove oven control by pulling control from mounting pins. Remove control from oven.
- E. Before installing new control, set voltage jumper (located at the bottom center of the oven control) to the proper (120/240V) position. Install the four push button extensions (included with the oven control) by pushing the extensions onto the four set buttons on control.
- F. Reassemble in reverse order and check system operation.
- G. Set the oven control for the proper operating mode. The 1600 series ovens have dual burner systems. The oven control must be set to the “Dual oven mode”. Set control as follows: With the oven power switch “off”, depress the “temp” and “down” buttons and turn the oven “on”. Control will indicate “Low Pro”. Release the buttons, the control will indicate “Temp to store”. Press the “temp” button. The control is now set for dual burner operation.

GENERAL ADVANTAGE SERIES

LETTER	PART #	DESCRIPTION
A	369110	Access window assembly
B	369929	Window retainer
C	369926	Window frame bottom
D	369925	Glass, access window
E	369927	Window frame, top
F	369930	Screw, 10-32x1/4
G	369211	Thumb screw
H	369058	Baffle
I	370253	Drive cover, L.H.
J	1609	Oven top
K	370252	Drive cover, R.H.
L	369745	Hinge assy., right
M	369723	Door assy., small
N	369783	Latch, spring
O	369717	Finger retaining bracket
P	369057	Screw, finger retaining bracket
Q	369501	Latch
R	369238	Leg
S	369030	Caster, High stand
	369390	Caster, Low stand
T	370167	Baffle, air return U.L., L.R. (S/N 35950 & below)
	370663**	Baffle, air return U.L. (S/N 35951 & above)
U	370166	Baffle, air return U.R. L.L. (S/N 35950 & below)
	370662**	Baffle, air return U.R. (S/N 35951 & above)
V	370168	Finger housing T-1, T-3, B-2, B-4 (S/N 35950 & below)
	370665***	Finger housing T-1, T-3, B-2, B-4 (S/N 35951 & above)
	370169	Finger housing T-2, T-4, B-1, B-3 (S/N 35950 & below)
	370664***	Finger housing T-2, T-4, B-1, B-3 (S/N 35951 & above)
W		Columnating plates- see Installation Operations manual.
X	369707	Finger cover
Y	369740	Handle assy.
Z	369718	Door assy. , large
AA	369931	Screw, 8-32x3/8
BB	369746	Hinge assy. left

**** Units from S/N 35951 and above DO NOT contain lower Air Return Baffles. These units only contain a total of two (2) Air Return Baffles which are placed above the top finger assemblies.**

***** These parts have minor design changes not shown in the exploded view drawing on page 19.**

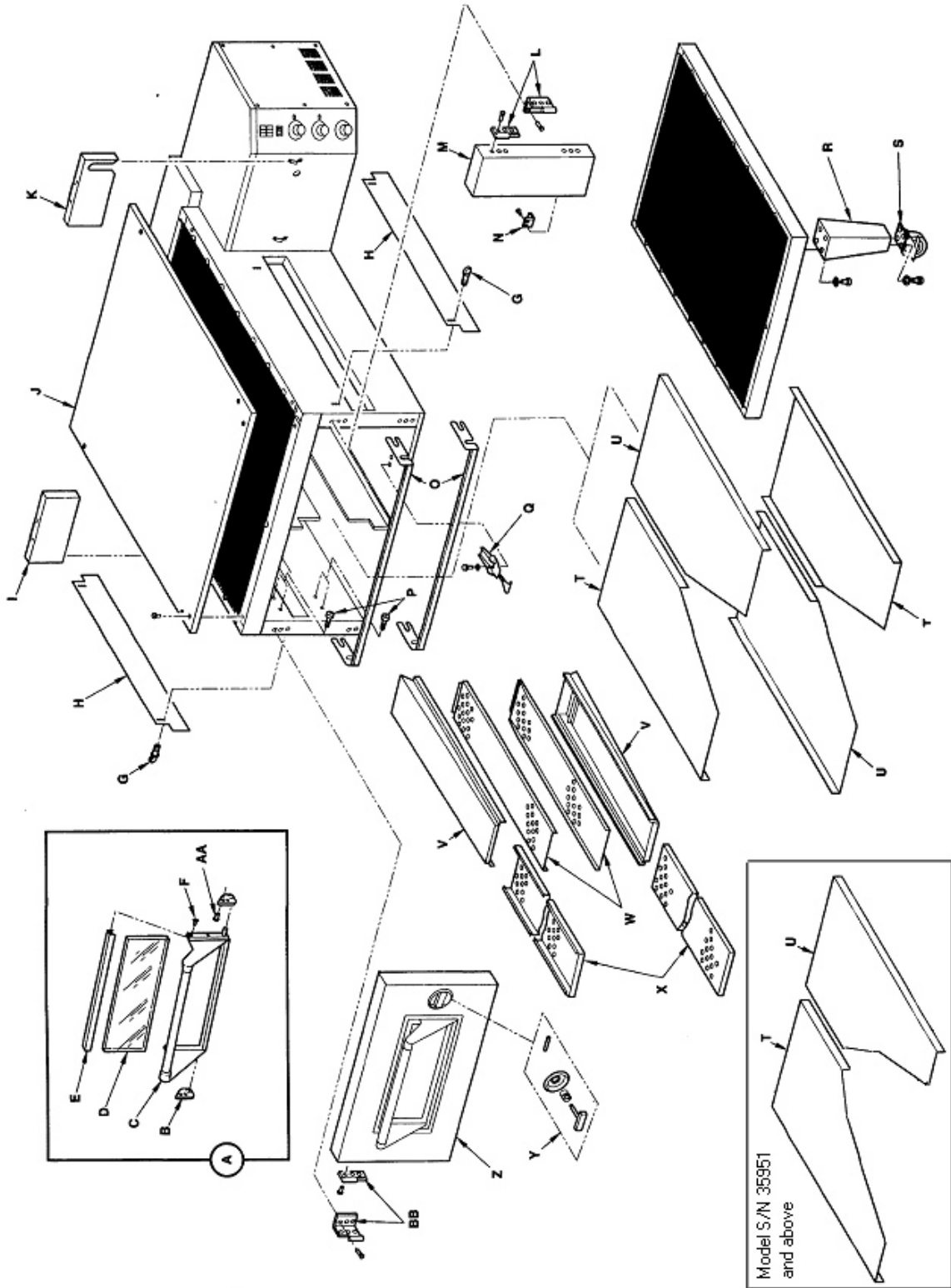

CONTROL BOX, RIGHT
1633-000-EA, 1634-000-EA

LETTER	PART #	DESCRIPTION
A	369158	Sprocket, 10 Tooth
B	370357	Thermocouple, Type K
C	369757	Main Orifice, Nat.
	369758	Main Orifice, LP
D	370186	Solenoid Valve
E	369590	Igniter/ Sensor Assembly (S/N L31478 & below)
	370397	Igniter/ Sensor Assembly (S/N L31479 & above)
F	369937	Venturi, Nat.
	369773	Venturi, LP
G	369401	Air Shutter Assembly
H	369589	Burner Blower Motor
I	369580	Gas Valve NAT/LP (S/N L31478 & below)
	370400	Gas Valve NAT/LP S/N L31479 & above)
J	370031	By-pass Orifice, Nat.
	369557	By-pass Orifice, LP
K	369025	Blower Air Switch
L	369571	Connector
M	370296	Wire Hanger
N	369378	Cooling Fan
O	369575	Air Pressure Switch
P	369771	Reset Switch, Ignition Control
Q	369192	Capacitor
R	369368	Hi-Limit Thermostat, Oven
S	369574	Spark Generator
T	357107	Fuse Holder
U	369013	Fuse, 3A
	369014	Fuse, 10A
V	369579	Solid State Alarm
W	369431	Thermostat, Control Box Hi-Limit
X	369507	Thermostat, Cooling Fan
Y	370241	Transformer, Control (24 VAC)
Z	370360	Capacitor, Conveyor Motor
AA	370361	Conveyor Motor
BB	370251	Control Box Top, RH
CC	370355	Control, Oven
DD	370256	Side Panel, RH
EE	370354	Facia, Label
FF	369432	On/Off Switch
GG	369422	Relay
HH	370359	Reversing Switch, Conveyor
II	369573	Ignition Control, (S/N L31478 & below)
	370401	Ignition Control, (S/N L31479 & above)
JJ	369689	Pressure Tap Fitting
Not shown	370495	Bracket, cooling fan RH S/N L32631 and above

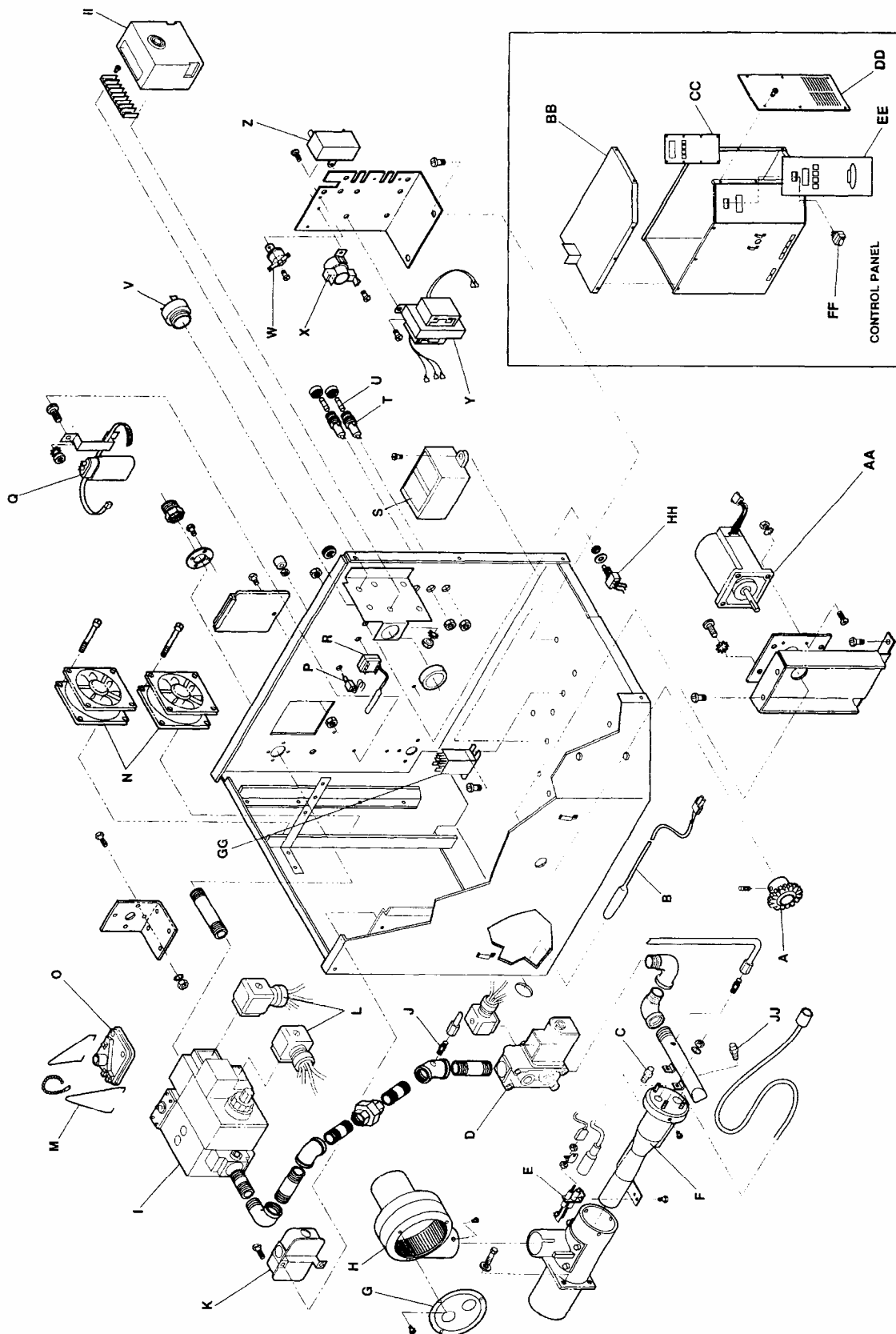

CONTROL BOX, LEFT

1633-000-EA, 1634-000-EA

LETTER	PART#	DESCRIPTION
A	370358	Thermocouple with extension
B	369507	Thermostat, cooling fan
C	369431	Thermostat, control box hi-limit
D	369573	Ignition control, (S/N L31478 & below)
	370401	Ignition control, (S/N L31479 & above)
E	369771	Reset switch, ignition control
F	357107	Fuseholder
G	369014	Fuse, 10A
H	369368	Thermostat, hi-limit
I	369378	cooling fan
J	369192	Capacitor
K	370296	Wire hanger
L	369575	Air pressure switch
M	369025	Air pressure switch
N	369580	Gas valve, (S/N L31478 & below)
	370400	Gas valve, (S/N L31479 & above)
O	369571	Connector
P	369589	Burner blower motor
Q	369590	Igniter/ sensor assy. (S/N 31478 & below)
	370397	Igniter/ sensor assy. (S/N 31479 & above)
R	369937	Venturi, Nat.
	369773	Venturi, LP
S	369757	Main orifice, Nat.
	369758	main orifice, LP
T	369689	Pressure tap fitting
U	370186	Solenoid valve
V	370031	By-pass orifice, Nat.
	369557	By-pass orifice, LP
W	369574	Spark generator
X	370272	Side panel, L.H.
Y	370250	Control box top, L.H.
Z	369579	Alarm
Not shown		Bracket, cooling fan, L.H. S/N L32631 and above

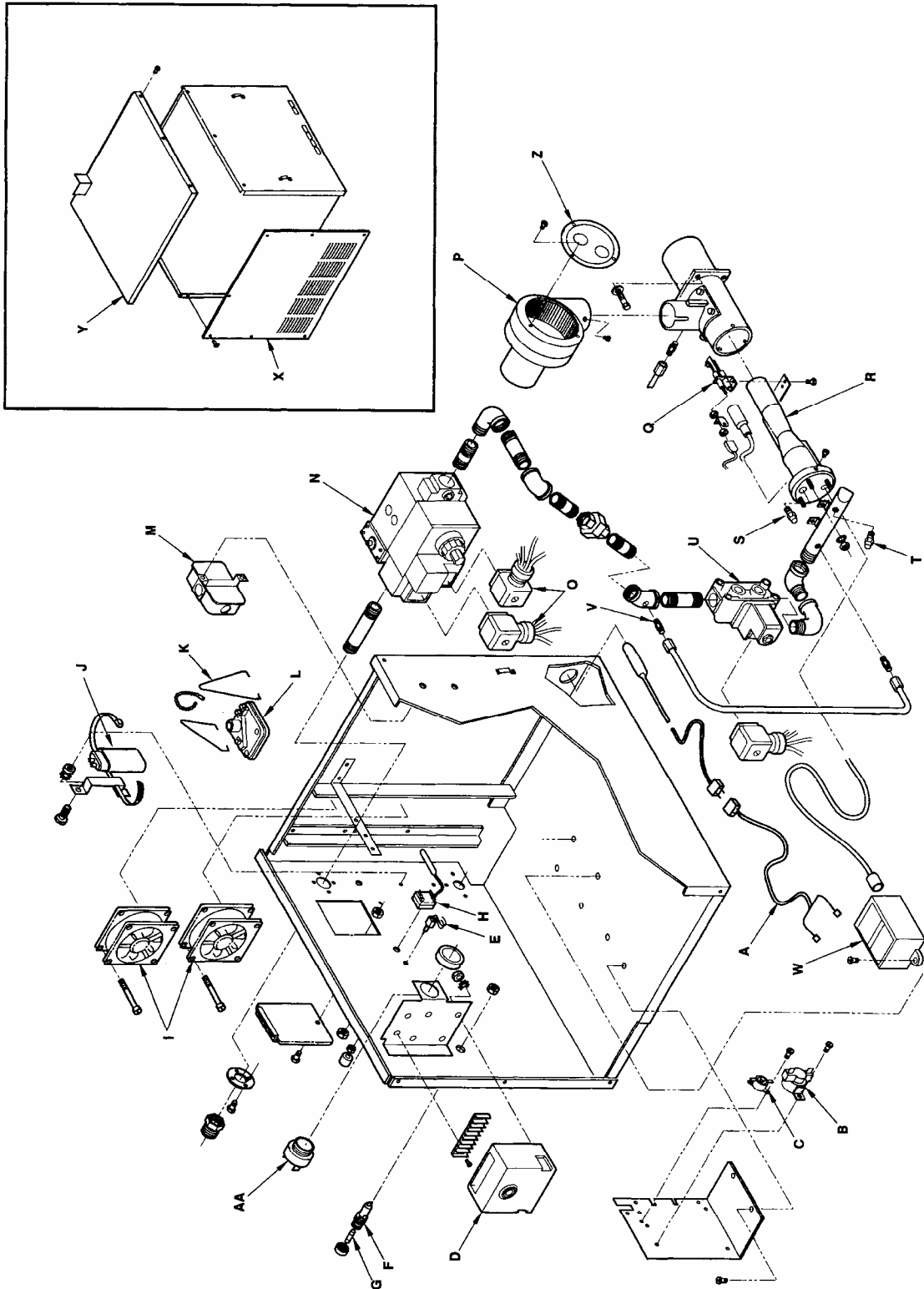

OVEN BACK
1633-000-EA, 1634-000-EA

LETTER	PART#	DESCRIPTION
A	369547	Wire form thermostat bulb
B	369725	Fan, clockwise rotation
C	369776	Fan shroud
D	369777	Stand-off
E	369778	Rear wall assy.
F	369761	Motor mount
G	369759	Motor, main fan 220/240V 50 Hz.
H	1627	Duct cap
I	369033	Motor clamp
J	370245	Rear duct
K	370246	Manifold assy.
L	368724	Fan, counter-clockwise rotation

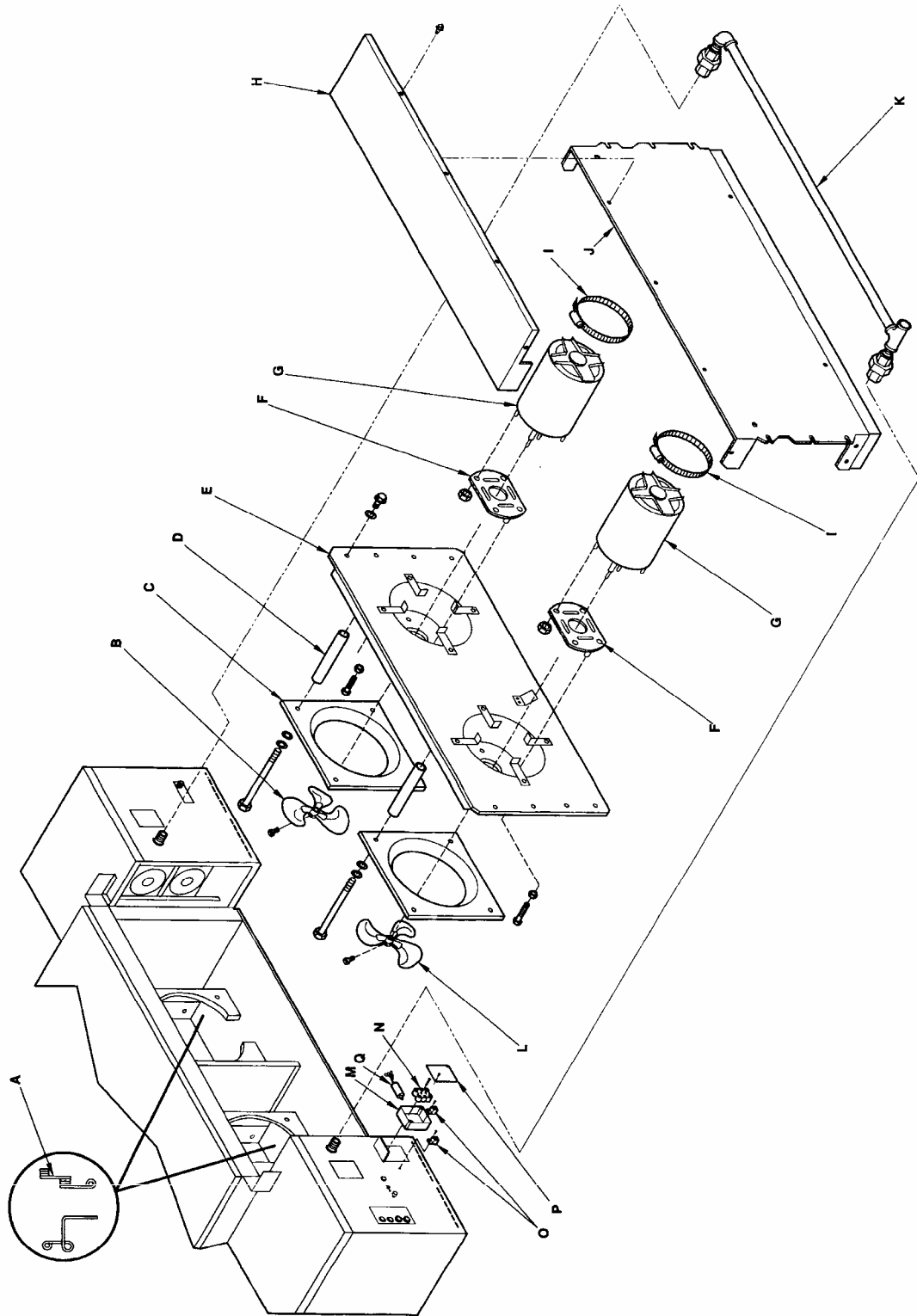

CONVEYOR

1633-000-EA, 1634-000-EA

LETTER	PART#	DESCRIPTION
A	369830	Complete conveyor
	369816	Conveyor belt, complete (30 inch wide belt)
	369163	Conveyor belt, complete (32 inch wide belt)
	370092	Belt, 1ft. section (30 inch wide belt)
	369362	Belt, 1ft. section (32 inch wide belt)
B	369825	Retaining ring
C	369813	Conveyor bearing block
D	369314	Roll, conveyor, notched
E	369812	Conveyor idler shaft
F	369160	Conveyor pan stop
G	369814	Connecting link (30 inch wide belt)
	369005	Connecting link (32 inch wide belt)
H	369811	Conveyor drive shaft
J	369161	Roller chain sprocket
K	369806	Crumb pan
L	370050	Conveyor frame
M	370247	Drive chain

