

SERVICE MANUAL

(DOMESTIC & INTERNATIONAL)

DUAL TECHNOLOGY FINISHER 1980 SERIES



Lincoln Foodservice Products, LLC
1111 North Hadley Road
Fort Wayne, Indiana 46804
United States of America

Telephone: (260) 459-8200
U.S. Fax: (888) 790-8193
Int'l Fax: (260) 436-0735
Service Hotline: (800) 678-9511

www.lincolnfp.com



SEQUENCE OF OPERATION

DUAL TECHNOLOGY FINISHER

1981	120/208VAC	60 HZ.	3 PHASE
1982	120/240VAC	60 HZ.	3 PHASE

NOTE: DTF must be placed on an oven stand for approved operation. No other surface may be used for operation.

POWER SUPPLY	Electrical power to be supplied to the oven by a five conductor service for three phase. Black conductor is hot. Red conductor is hot. Orange conductor is hot. White conductor is neutral. Green conductor is ground.
MAIN FAN CIRCUIT	Power is permanently supplied to the normally open main heater relays, the upper and lower IR relays, the oven control, and, through the 10 A. motor and control fuses, to the normally open main fan relay. Power is also supplied through a normally closed hi-limit thermostat to terminal number 1 of the 30 minute cool down timer, and to the main power switch. Closing the main power switch enables the 30 minute cool down timer. The 30 minute cool down timer supplies line voltage to the coil of the main fan relay, its contacts now close, supplying 208/240VAC to the main fan motor. Voltage is also supplied to the primary of the control transformer, the conveyor motor, the oven control.
TEMPERATURE CONTROL	Closing the main power switch supplies 208/240VAC to the primary of the control transformer. Secondary voltage, 24VAC, is supplied to the oven control. The oven control is set to desired temperature. The thermocouple will provide varying millivolts to the oven control. The oven control supplies voltage to the coil of the heater relays at intermittent intervals to maintain the desired temperature. The display on the oven control will indicate when the main heater relay is energized. NOTE: The display also indicates oven temperature.
INFRARED HEAT	Adjusting the oven control will allow up to four infrared elements to be operated. The control will energize the required relays, supplying 208/240VAC to the infrared heaters.
CONVEYOR DRIVE	Closing the main power switch supplies 208/240VAC to the conveyor motor and to the primary of the control transformer. Secondary voltage, 24VAC, is supplied to the oven control. Setting the oven control to the desired time, outputs voltage, through a reversing switch and capacitor, to the conveyor motor.
AUTOMATIC COOL DOWN	When the machine is started, the time delay relay timing circuit is enabled, permitting the main fan to operate for approximately 30 minutes after the machine is shut off, to cool the machine. The 30-minute time delay relay will keep the coil of the main fan relay energized, maintaining operation of the main fan motor for 30 minutes.

SCHEMATIC DIAGRAM DOMESTIC MODELS

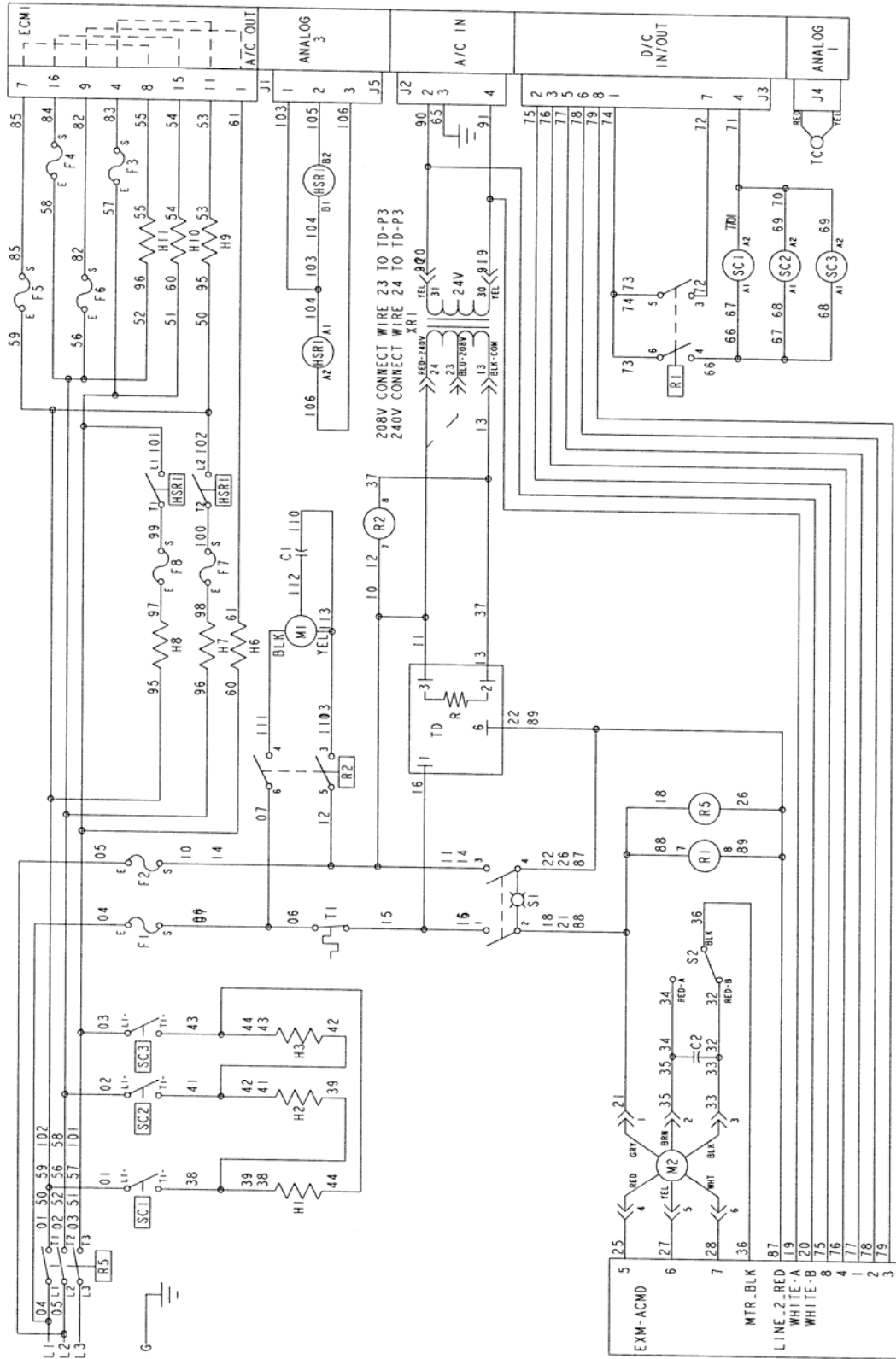

- C1 - CAPACITOR, MAIN FAN
- C2 - CAPACITOR, CONVEYOR MOTOR
- ECM I - CONTROL, OVEN
- EXM-ACMD - CONTROL, CONVEYOR MOTOR
- F1, F2 - FUSE, MOTOR & CONTROLS
- F3-F5 - FUSE, IR, BOTTOM
- F6-F8 - FUSE, IR, TOP
- H1-H3 - HEATER, CIRCULAR, 2000W
- H6-H8 - HEATER, INFRARED, UPPER, 1500W
- H9-H11 - HEATER, INFRARED, LOWER, 1500W
- HSR1 - RELAY, 2 POLE SOLID STATE
- M1 - MOTOR, MAIN FAN
- M2 - MOTOR, CONVEYOR
- R1 - RELAY, SSR/SWITCH SOLID STATE DETECT
- R2 - RELAY, MAIN FAN
- R5 - RELAY, MAIN POWER
- S1 - SWITCH, MAIN
- S2 - SWITCH, CONVEYOR REVERSING
- SC1-SC3 - SSR, MAIN HEATER
- T1 - THERMOSTAT, OVEN HIGH LIMIT
- TC - THERMOCOUPLE, TYPE K
- TD - TIME DELAY, 30 MINUTES
- XRI - TRANSFORMER, CONTROL

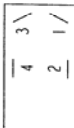

DTF-8/16/18
DOMESTIC

SI CONFIGURATION, REAR VIEW

SCHEMATIC DIAGRAM EXPORT MODELS

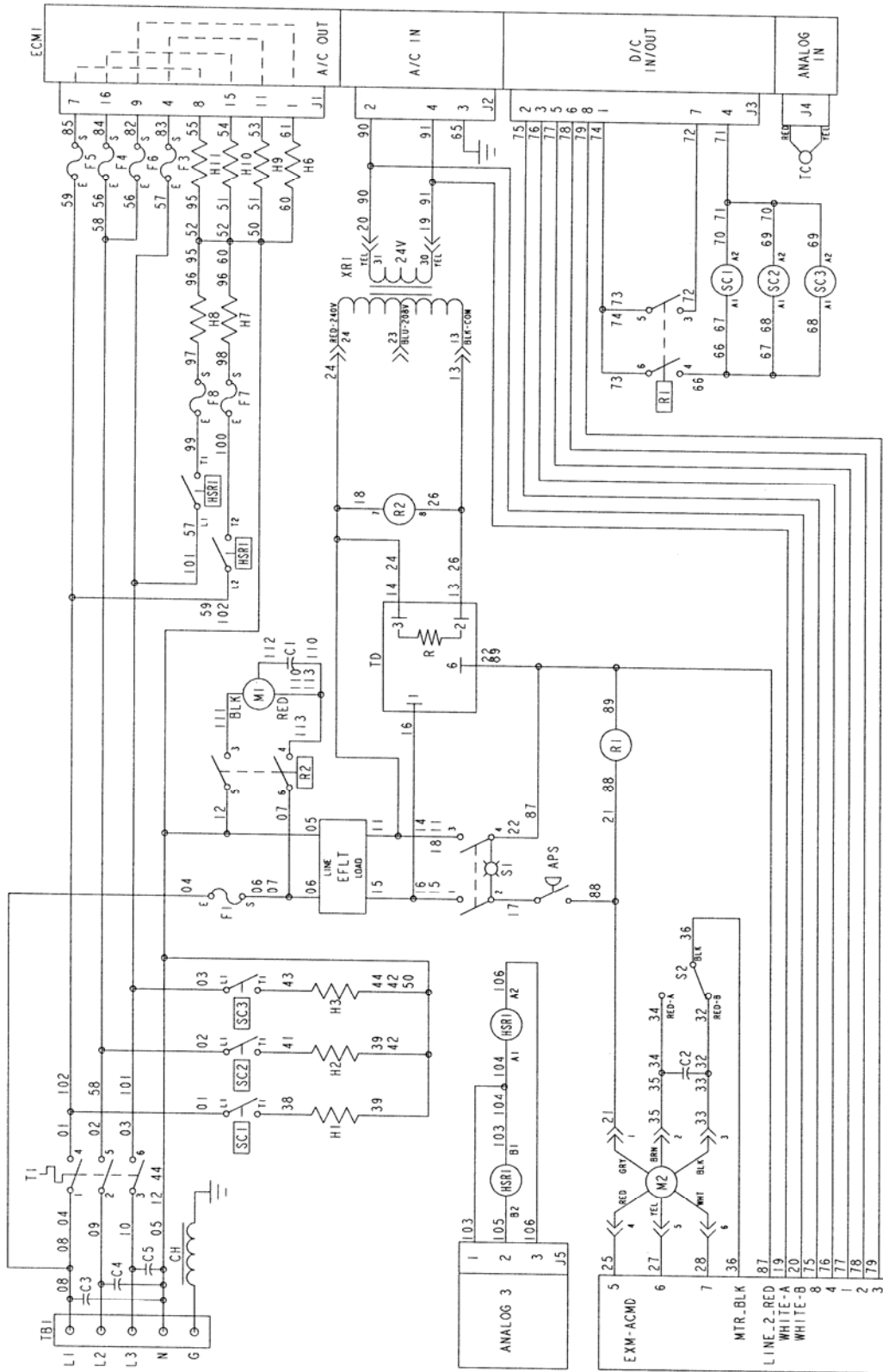

- APS - SWITCH, AIR PRESSURE
- C1 - CAPACITOR, MAIN FAN
- C2 - CAPACITOR, CONVEYOR MOTOR
- C3-C4-C5 - CAPACITOR, NOISE SUPPRESSION
- CH - COIL, NOISE SUPPRESSION
- ECMI - CONTROL, OVEN
- EFLT - FILTER, LINE
- F1, F3-F8 - FUSE, MOTOR, HEATERS & CONTROLS
- H1-H3 - HEATER, MAIN
- H6-H11 - HEATER, IR
- HSR1 - RELAY, 2 POLE SOLID STATE
- M1 - MOTOR, MAIN FAN
- M2 - MOTOR, CONVEYOR
- EXM-ACMD - CONTROL, CONVEYOR MOTOR
- R1 - RELAY, MAIN HEATER
- R2 - RELAY, MAIN FAN
- S1 - SWITCH, MAIN
- S2 - SWITCH, CONVEYOR REVERSING
- SC1, SC2, SC3 - RELAY, SOLID STATE
- T1 - THERMOSTAT, OVEN HIGH LIMIT
- TBI - TERMINAL BLOCK, MAIN POWER
- TC - THERMOCOUPLE, TYPE K
- TD - TIME DELAY, 30 MINUTES
- XR1 - TRANSFORMER, CONTROL

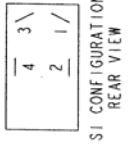

TROUBLESHOOTING GUIDE

1981	120/208 VAC	60 HZ.	3 PHASE
1982	120/240 VAC	60 HZ.	3 PHASE

SYMPTOM	POSSIBLE CAUSE	EVALUATION
Oven fan will not run	Incoming power supply	Check circuit breakers. Reset if required. Call power co. if needed.
	Fuses, 10 Amp, motor and controls	Check, replace if necessary.
	Fuse holder	Check, replace if necessary.
	Hi-limit thermostat, Oven cavity	Terminals are normally closed. If open, reset thermostat and retest. If thermostat will not hold for maximum oven temperature, and oven is not exceeding temperature setting, check for proper location of capillary bulb in its spring holder. If the capillary checks okay, replace the hi-limit thermostat.
	Switch, main power	Check continuity between switch terminals. Replace switch as needed.
	30 minute time delay relay	Check for supply voltage to 30 minute time delay relay at terminals #1 and #6. If no voltage is present, trace wiring back to main power switch. If there is supply voltage at terminals #1 and #6, check for output voltage at terminals #2 and #3. If there is incoming voltage but no output voltage, and the main power switch is on, replace the 30 minute time delay relay.
	Relay, main fan	Check for supply voltage to relay contacts, if no voltage is present, trace wiring back to power supply. Check for supply voltage to the coil of the main fan relay. If no voltage is present, trace wiring back to the 30 minute time delay relay. If voltage is present, check to insure contacts are closing. Replace as needed.
	Main fan motor	Check for supply voltage at motor. If no voltage is present, trace wiring back to circuit breakers. WITH POWER OFF: Check for opens, shorts or grounds. Turn fan blade to check for locked rotor.
	Capacitor	Check for shorts or grounds. WARNING: Capacitor has a stored charge, discharge before testing.
Oven will not heat	Main fan motor	Check for main fan operation. If it is not operating, refer to "Oven fan will not run".
	Control transformer	Check for 208/240VAC supply to the primary of the control transformer. If no voltage is present, trace wiring back to the main power switch. If voltage is present, check for 24VAC at the transformer secondary. If there is primary voltage, but no secondary voltage, replace the control transformer.
	Oven control	Check for 24VAC supply to control. If no voltage is present, trace wiring back to control transformer. If 24VAC is present, check for a read-out on the display. If there is 24VAC supplied, but there is no read-out on the control display, replace the oven control. If there is a read-out on the control, set the control to maximum temperature (see installation operations manual for temperature adjustment). With the control set at maximum temperature, check for supply voltage to the oven control at terminals J3-12 and J3-3. If there is no voltage present, trace wiring back to the air pressure switch. If there is voltage present, check for

		output voltage at the Main heater relay (R1). If there is voltage at the Main heater relay, proceed to “Main heater relay” for next check. If there is no voltage at the Main heater relay, trace wiring back to the oven control. If there is no voltage output at the oven control, check the read-out on the control. If the control reads “PROBE FAIL”, this indicates that the thermocouple has failed or become disconnected from the oven control.
	Thermocouple	Check to be sure that the thermocouple is securely connected to the oven control. If the thermocouple is connected to the oven control, and the control indicates “PROBE FAIL”, disconnect the thermocouple from the oven control and measure the resistance of the thermocouple. The thermocouple should read approx. 11Ω. If these readings are not achieved, replace the thermocouple. If these readings are correct, proceed.
	Oven control	If the thermocouple checks good, but the oven control display indicates that there is a thermocouple failure, replace the oven control. If the oven control indicates a temperature reading but the oven will not heat, proceed.
	Thermocouple	WITH POWER ON AND THERMOCOUPLE ATTACHED TO THE OVEN CONTROL: Measure the DC millivolt output of the thermocouple. Refer to the thermocouple chart (located in the “Removal” section of the manual) for proper millivolt readings. If these readings are not achieved, replace thermocouple.
	Oven control	If the thermocouple checks good, but there is no voltage output to the Main heater relay, replace the oven control. If there is voltage output to the Main heater relay, proceed.
	Main heater relay	Check for supply voltage to the relay coil. If voltage is present and the relay will not activate, replace the Main heater relay. Also check each relay contact for high voltage input and output.
	Heating element(s)	Check the Amp draw on each power leg for proper load. Check the specification plate for rating information. If the amp draw is high or low, check the individual elements for opens, shorts and proper resistance. WITH POWER OFF: To check resistance of the elements, remove all leads from the elements and use a digital multimeter. The element resistance should be as follows: Circular element 120V – 7.5 ohms approx. Side elements 120V – 14 ohms approx. Replace heating elements as needed.
No Infrared Heating	Main fan motor	Check for main fan operation. If it is not operating, refer to “Oven fan will not run”.
	Infrared heater relay	Check for supply voltage to the relay coil. If no voltage is present, trace wiring back to Infrared heater switch. If voltage is present and the relay will not activate, replace the Infrared heater relay. Also check each relay contact for high voltage input and output.
	Infrared Heating element(s)	Check the Amp draw on each power leg for proper load. Check the specification plate for rating information. If the amp draw is high or low, check the individual elements for opens, shorts and proper

		<p>resistance.</p> <p>WITH POWER OFF: To check resistance of the elements, remove all leads from the elements and use a digital multimeter.</p> <p>The element resistance should be as follows: 208V – 45 ohms approx. 240V – 58 ohms approx.</p> <p>Replace heating elements as needed.</p>
Oven heats with switch off	Main heater relay or Infrared heater relay	The Main heater relay or Infrared heater relay has probably failed in the closed position. If there is no voltage to the operating coil, but there is high voltage at the relay output, replace the heater relay.
Intermittent heating	Thermal/overload of motor	The main fan motor is equipped with internal thermal protection and will cease to operate if overheating occurs. As the motor overheats and then cools, this will cause the oven to cycle on and off intermittently. Improper ventilation or lack of preventive maintenance may cause this. Also, most of the problems listed under "Oven will not heat" can cause intermittent failure.
Conveyor will not run	NOTE: Display will indicate "Belt Jam"	
	Power supply	Check circuit breakers, reset if required. Check power plug to be sure it is firmly in receptacle. Measure incoming power, call power co. if needed.
	Fuse, 10 Amp	Check, replace if necessary.
	Fuse holder	Check, replace if necessary.
	Hi-limit thermostat, oven cavity	Terminals are normally closed. If open, reset thermostat and retest. If thermostat will not hold for maximum oven temperature, and oven is not exceeding temperature setting, check for proper location of capillary bulb in its spring holder. If the capillary checks okay, replace the hi-limit thermostat.
	Switch, Main Power	WITH POWER OFF: Check continuity between switch terminals. Replace switch as needed.
	Control transformer	Check for supply voltage to the primary of the control transformer. If no voltage is present, trace wiring back to the oven power relay. If voltage is present, check for 24 VAC at the transformer secondary. If there is primary voltage but no secondary voltage, replace control transformer.
	Conveyor motor	<p>Check for supply voltage to the conveyor motor. If no voltage is present, trace wiring back to the primary of the control transformer. If voltage is present and the motor will not run, check the motor windings for opens or shorts.</p> <p>WITH POWER OFF: Check the motor windings as follows: Grey to black - 236 ohms approx. Grey to brown - 236 ohms approx. Brown to black - 472 ohms approx.</p> <p>If any of the above fails, replace conveyor motor.</p>
	Capacitor, conveyor motor	<p>Check for shorts or grounds. Replace capacitor as needed.</p> <p>WARNING: Capacitor has a stored charge, discharge before testing.</p>
	Switch, conveyor reversing	Check continuity between switch terminals. Replace switch as needed.
	Oven control	If there is supply voltage to the motor, and the motor, motor capacitor, and reversing switch check good,

		replace the oven control.
Conveyor motor runs, but there is no speed display	Oven control	Check for output voltage from oven control to hall effect sensor (sensor is located in conveyor motor). Measure voltage at the motor connector, red wire and yellow wire. Voltage should be approx. 10VDC. If no voltage is present, trace wiring back to oven control. If there is no voltage present at the oven control, replace the oven control.
	Conveyor motor	If there is voltage supplied to the hall effect sensor, check for a frequency output from the hall effect sensor. Measure frequency across the yellow and white wires at the motor connector. Frequency reading should be approx. 25 – 100 Hz. If these readings are not achieved, replace conveyor motor. If the readings are achieved, proceed.
	Oven control	If the hall effect sensor readings are correct, but there is no speed indicated on the display, replace the oven control.

REMOVAL, INSTALLATION AND ADJUSTMENT

DUAL TECHNOLOGY FINISHER

CAUTION!

BEFORE REMOVING OR INSTALLING ANY COMPONENT IN THE DUAL TECHNOLOGY FINISHER, BE SURE TO DISCONNECT THE ELECTRICAL POWER SUPPLY.

MOTOR, MAIN FAN - REPLACEMENT

1. Shut off power at main breaker.
2. Remove conveyor and finger assemblies from oven (see installation operations manual).
3. Remove front plenum assembly. Measure location of main fan on motor shaft for reassembly. Loosen two set screws and remove main fan from motor shaft.
4. Remove rear cover. Disconnect wiring from motor. Remove motor and motor mount assembly from back of oven.
5. Measure proper location of cooling fan on motor shaft for reassembly. Remove cooling fan. Remove motor from motor mount.
6. Reassemble in reverse order and test for proper operation.

CAPACITOR, MAIN FAN MOTOR – REPLACEMENT

1. Shut off power at main breaker.
2. Remove rear cover, open rear access panels.
3. Discharge capacitor, disconnect wiring and remove capacitor.
4. Reassemble in reverse order and check system operation.

MAIN FAN - REPLACEMENT

See “MOTOR, MAIN FAN” above.

SWITCH, ON/OFF - REPLACEMENT

1. Shut off power at main breaker.
2. Remove control box top.
3. Depress clips on sides of switch and remove switch from front panel.
4. Disconnect all wires from switch. Mark all wires for reinstallation.
5. Reassemble in reverse order and check system operation.

RELAY, TIME DELAY - REPLACEMENT

1. Shut off power at main breaker.
2. Remove rear cover, open rear access panels.
3. Remove wires from time delay relay and mark wires for reinstallation.
4. Remove mounting screw and remove time delay relay.
5. Reassemble in reverse order and check system operation.

RELAY, MAIN FAN - REPLACEMENT

1. Shut off power at main breaker.
2. Remove rear cover, open rear access panels.
3. Remove wires from main fan relay and mark wires for reassembly.
4. Remove mounting screws and remove main fan relay.
5. Reassemble in reverse order and check system operation.

FUSE HOLDER - REPLACEMENT

1. Shut off power at main breaker.
2. Remove rear cover, open rear access panels.
3. Remove wires from appropriate fuse holder and mark wires for reassembly.
4. Remove mounting screws from fuse holder and remove fuse holder.
5. Reassemble in reverse order and check system operation.

RELAY, MAIN HEATER – RELAY, INFRARED HEATER - REPLACEMENT

1. Shut off power at main breaker.
2. Remove rear cover, open rear access panels.
3. Remove wires from appropriate relay and mark wires for reassembly.
4. Remove mounting screws from relay and remove relay.
5. Reassemble in reverse order and check system operation.

REVERSING SWITCH, CONVEYOR - REPLACEMENT

1. Shut off power at main breaker.
2. Remove rear cover, open rear access panels.
3. Remove wires from reversing switch and mark wires for reassembly.
4. Remove mounting nut from reversing switch and remove reversing switch.
5. Reassemble in reverse order and check system operation.

TRANSFORMER, CONTROL - REPLACEMENT

1. Shut off power at main breaker.
2. Remove rear cover, open rear access panels.
3. Remove wires from control transformer and mark wires for reassembly.
4. Remove mounting screws and remove control transformer.
5. Reassemble in reverse order and check system operation.

CAPACITOR, CONVEYOR MOTOR – REPLACEMENT

1. Shut off power at main breaker.
2. Remove control box top and rear control box cover.
3. Discharge capacitor, remove wiring from capacitor and remove one mounting screw.
Remove capacitor.
4. Reassemble in reverse order and check system operation.

CONVEYOR MOTOR – REPLACEMENT

1. Shut off power at main breaker.
2. Remove coupling from conveyor shaft (one screw at end of motor shaft).
3. Remove control box top and rear control box cover.
4. Disconnect wiring for motor and remove motor mounting screws. Remove conveyor motor and mounting bracket.
5. Remove conveyor motor from mounting bracket.
6. Reassemble in reverse order and check system operation.

THERMOCOUPLE – REPLACEMENT

1. Shut off power at main breaker.
2. Remove control box top. Remove rear cover, open rear access panels. Remove right side heating element cover.
3. Remove mounting screws and remove thermocouple from oven cavity.
4. Disconnect thermocouple from main control, remove thermocouple.
5. Reassemble in reverse order and check system operation.

THERMOCOUPLE MEASUREMENT

TEMPERATURE (°F)	D.C. MILLIVOLTS
200°	2.8
250°	4.0
300°	5.1
350°	6.0
400°	7.1
450°	8.2
500°	9.3
550°	10.4
600°	11.5

THERMOSTAT, HI-LIMIT – REPLACEMENT

1. Shut off power at main breaker.
2. Remove rear cover, open rear access panels, remove right side heating element cover.
3. Remove hi-limit thermostat mounting plate. Remove hi-limit thermostat.
4. Reassemble in reverse order and check system operation. Be sure to reset thermostat before testing.

HEATING ELEMENT, MAIN – REPLACEMENT

1. Shut off power at main breaker.
2. Remove conveyor, finger assemblies and plenum front. Remove rear cover, open rear access panels and remove appropriate heating element cover.
3. Remove wires from heating element and mark wiring for reassembly.
4. Remove mounting screws and remove heating element.
5. Reassemble in reverse order and check system operation.

HEATING ELEMENT, INFRARED – REPLACEMENT

1. Shut off power at main breaker.
2. Remove conveyor and lower finger assemblies. Remove front conveyor support from oven cavity.
3. Remove front cover and heating element cover. Disconnect wiring from heating element and mark wires for reassembly.
4. Reassemble in reverse order and check system operation.

MAIN CONTROL – SETTINGS

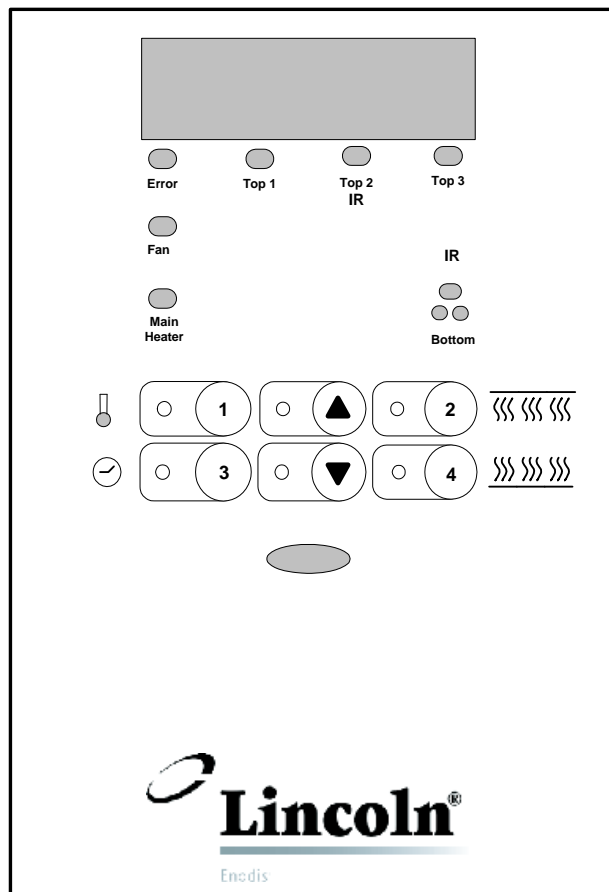

START UP

1. Push the “On Off” (O / |) switch to the “ON” position. The display will indicate “**SELECT PROGRAM**”
2. Press the **#1 PROGRAM BUTTON**. The toasting program will indicate “**SANDWICH**” The #1 program button will blink. (Buttons #2, #3 and #4 can be used for other menu item programs.)
3. Programming the unit to desired settings:

To enter the program mode, press and hold the **UP BUTTON** for 5 seconds. The **UP** and **DOWN BUTTONS** will light indicating the control is in a change status.

- a. Press the **TEMPERATURE BUTTON (#1)** to see existing toasting temperature. Use the **UP or DOWN BUTTONS** to change to desired temperature.
 - b. Press the **TIME BUTTON (#3)** to see existing toasting time. Use the **UP or DOWN BUTTONS** to change to desired toasting time.
4. The unit will return to normal operations 10 seconds after the last button is pushed and saves the latest program settings.
 5. Preheat toaster for 30 minutes.

COOL DOWN CYCLE

1. Push the “On Off” (O / |) switch to the “OFF” position. The unit’s main fan will run for approximately 30 minutes after shutting off in a cool down mode.

PROGRAM MODE

1. To enter the **PROGRAM MODE** press and hold the **UP BUTTON** for 5 seconds. Each button has a light that indicates when it can be used. When no buttons are pressed for 10 seconds the unit will exit the program and retain last entry.
2. Use the **UP and DOWN BUTTONS** to view or change;
 - a. **TEMPERATURE SETPOINT = TEMPERATURE BUTTON (#1)**
 - b. **TOP IR ON/OFF = (#2) BUTTON**
 - c. **COOK TIME VALUE = (#3) BUTTON**
 - d. **BOTTOM I/Rs ON/OFF STATUS = (#4) BUTTON**

The **TOP I/R** Icon follows the 8 available selections

The **BOTTOM I/R** Icon follows the 8 available selections:

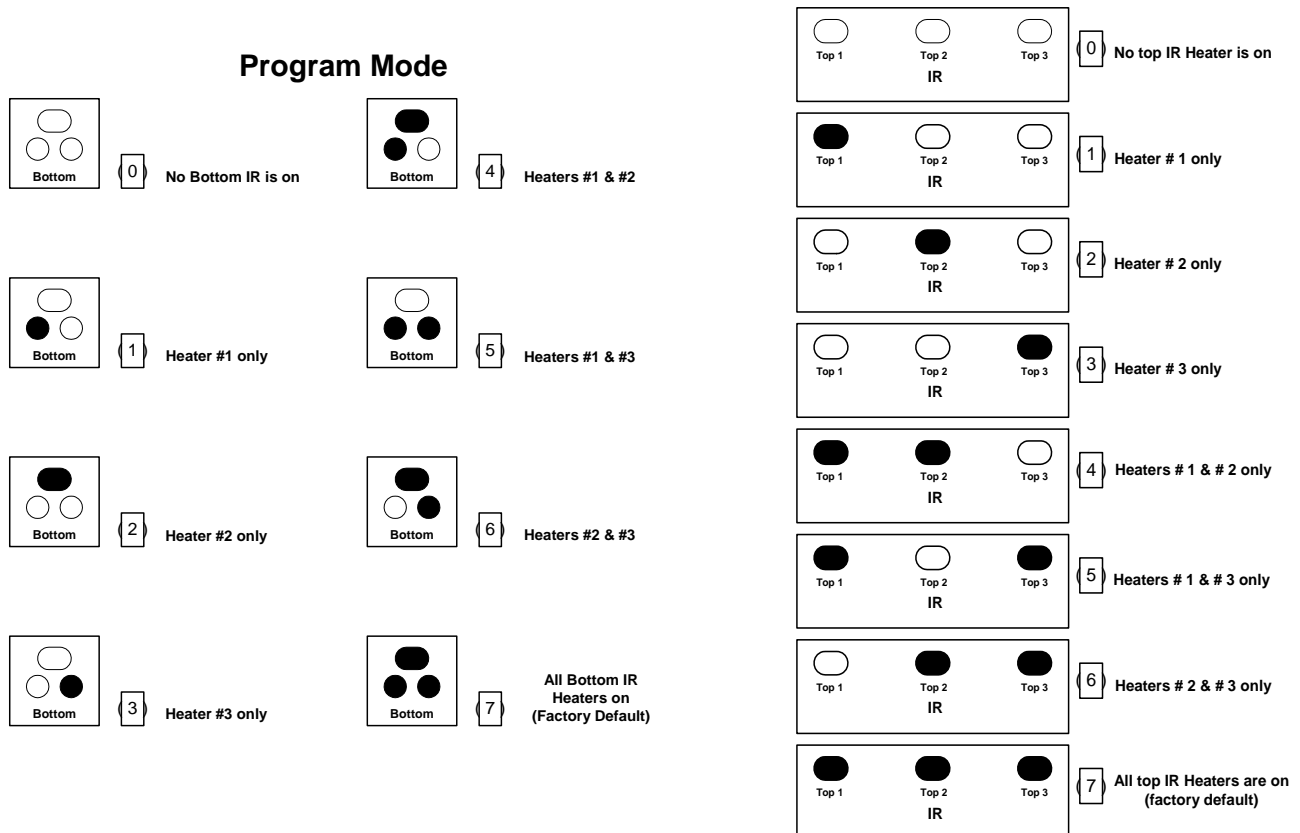

3. Set **TEMPERATURE UNITS (C° or F°)**.
 - a. Press and hold **BUTTON #1** for 20 seconds to change the **C or F** value.
 - b. To change again, repeat step **a**.
4. Set **TEMPERATURE DISPLAY** between **REAL** and **SETPOINT**.
 - a. Press and hold **BUTTON #4** for 20 seconds.
 - b. To change again, repeat step **a**.
5. Set **LANGUAGE SELECTION**.
 - a. Press and hold **BUTTON #2** for 20 seconds. Use **UP** and **DOWN** **BUTTONS** to select language.

SUBSET POINTS MENU

1. To enter **SUBSET MENU**, press and hold the **TIME BUTTON (#3)** for 20 seconds. **BUTTON (#3)** toggles between parameter names and values.
 - a. If parameter name is displayed, use the **UP** and **DOWN** arrow buttons to browse through previous/next parameter in the list.
 - b. If parameter value is displayed, use the **UP** and **DOWN** arrow buttons to change the parameter value to within the allowed limits.
2. Select the parameter to be adjusted by pressing the **TIME BUTTON (#3)** when the parameter is displayed.
3. Use the **UP** and **DOWN** arrow buttons to change the value within the allowed limits. (See Chart below).
4. To **EXIT** the menu, press **TIME BUTTON (#3)** for 3 seconds. Or, if no button is pressed for 30 seconds, the unit will automatically **EXIT** the **SUBSET MENU**.

SUBSET LIMITS / DEFAULTS

PARAMETER	VALUE LIMITS	FACTORY DEFAULT
DEFAULT SET POINT (Preheat Mode)	F: 32° to 700° C: 0° to 370°	F: 575° C: 300°
Main Heater PROBE OFFSET	F: -200° to 200° C: -129° to 94°	F: -60° C: -33°
Main Heater MAXIMUM SET POINT	F: 32° to 700° C: 0° to 370°	F: 650° C: 340°
Main Heater MINIMUM SET POINT	F: 32° to 700° C: 0° to 370°	F: 215° C: 100°
DEFAULT COOK TIME	0:14 to 10:00 (MM:SS)	0:21 (MM:SS)
CALIBRATION (Conveyor Speed)	-4 to 4 See instructions below	0

NOTE

CALIBRATION instructions: The calibration must be done at 33 seconds of cook time. A positive value in this parameter accelerates the conveyor and a negative value decelerates the conveyor.

SYSTEM DIAGNOSTICS

SAFE MODE: Occurs when the unit detects a defective temperature probe.

- a. Display will scroll **SAFE MODE – CALL SERVICE**.
- b. Main Heater is off.
- c. Selected COOK program light is on.
- d. Top and Bottom I/R heaters are on.
- e. Error light is on.
- f. **ALARM** sounds. (Can be turned off by pressing the **DOWN ARROW BUTTON**.)
- g. **COOK PROGRAM** and **SUBSET MENU** modes are not accessible.
- h. Unit can be restarted after a 30 minute **COOLDOWN CYCLE**.

SHUTDOWN MODE: Occurs when the unit detects a conveyor error.

- a. Display will scroll **SHUTDOWN - CALL SERVICE**.
- b. Main Heater is off.
- c. Top and Bottom I/R Heaters are off.
- d. **ALARM** sounds. (Can be turned off by pressing the **UP ARROW BUTTON**.)
- e. Unit can be restarted after 30 minute **COOLDOWN CYCLE**.

TEMPERATURE CALIBRATION

Calibration is to be performed with oven control set at 650° F, with the belt speed set at 4:00 minutes and all IR's off. The cavity temperature is to be measured in the center of the oven cavity with the temperature-sensing device resting on the conveyor belt.

Calibration must be done with all covers, fingers, air washes and conveyor belt in place to ensure accuracy for Gecko-equipped DTT ovens.

1. If oven is not on, turn oven on. Display will light up and run through start-up sequence. After start-up sequence, display will scroll "Select Program". Press and release the button labeled "3". Display will scroll "Menu Item 3".
2. To set the oven for calibration, simply press and hold the button with the arrow pointing up ("up arrow"). After about 5 seconds, the display will change to read the correct temperature set point and the light next to the button number will become solid rather than flashing. If the "up arrow" button is not released the set point will begin to go up unless it is already at maximum value. Use the up/down arrows to adjust this set point to "650". Next press and release button "3" to bring up the belt speed set point. The light on this button should now be solid to indicate that this option is currently active. Adjust the up/down arrows to read "4:00". Press and release button "2" and the light by this button will come on. Use up/down arrows to change this setting to "0 (zero)". Above the numbered button are 5 labeled lights, the two on the far right indicate the state of the IRs. The light above the "Top IR" should be off. Last, press button "4" to set the lower IRs. The light on the bottom will turn on and lights above the label "Bottom" will show the status of the lower IRs. The display will show a number between 0 and 7. Use the arrow button to adjust this value to 0. The lights above the label "Bottom" will change to indicate which IRs are on and which are off. After properly

setting oven for calibration, do not press any buttons and the control will return to heat up mode automatically after about 10 seconds.

3. Allow oven to heat up. Light on button number “3” should flash until oven is up to temp set point, then light will become solid and oven will begin to cycle. Check the temperature being recorded in the oven cavity. This temperature should be within 5°F of 650°. If temp is below 645°F or above 655°F then the probe offset must be adjusted. The equation to be used for adjusting the offset is as follows:

Change in Probe Offset = Cavity Temp – Display Temp

Examples of adjusting the offset: If the Cavity Temp is 550°F and the Probe offset is 0 with the display temp set at 575°F, then the Probe Offset should be set around –25 (minus 25) to make the cavity temp equal to the Display Temp. If the Cavity Temp is at 565°F with the Display Temp set at 575°F, then the Probe Offset must change by –10 degrees. For example, if the Probe Offset was at –40 and the change in the Probe Offset is calculated to be –15 then the Probe Offset must be –55.

4. To access the Probe Offset option, press the hold button “3” for about 30 seconds. The display will scroll “Temperature Units” when the control enters the correct menu. Use the up/down arrow button to scroll through the options until “Probe Offset” scrolls across the display. At this point, press and release button “3” and the display will show the current set point of the Probe Offset. Default setting is –60. Use the up/down arrows to adjust the offset based on the calculated Change in Probe Offset from above. Once the Probe Offset is changed to the desired value, press and hold button “3” for 3 seconds to exit the menu. Oven will now return to the heat mode and the light next to button “3” should flash until oven reaches set temperature of 600°F. Check the cavity temperature again after oven temperature has stabilized to ensure that the Probe Offset is now correct.
5. Once the cavity temp and display temp match within 5° F, the calibration is complete.
6. Press Program 1 key. IRs will turn on, and the settings are preset. Maximum temperature setting is 650°F. Cavity temperature should reach 710°F to 760°F. Calibration is complete.

NOTE: Cavity temperature should not exceed 825°F. If Hi Limit trips replace Hi-Limit.

MAIN CONTROL – REPLACEMENT

1. Shut off power at main breaker.
2. Remove control box top, front panel and rear control box cover.
3. Disconnect all wiring from control and mark all wiring for reassembly.
4. Remove mounting screws from main control and remove main control board.
5. This is a two piece control, be sure to replace both parts when the control is replaced. Reassemble in reverse order and check system operation.

CONVEYOR DISASSEMBLY FOR CLEANING

Pull conveyor out the right end. Place on table or work surface.

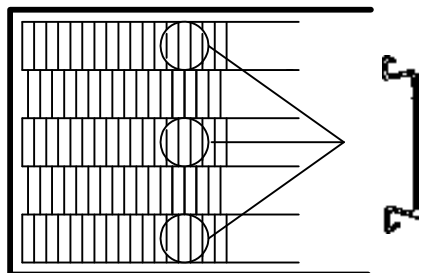

CONNECTING LINKS IN THREE PLACES

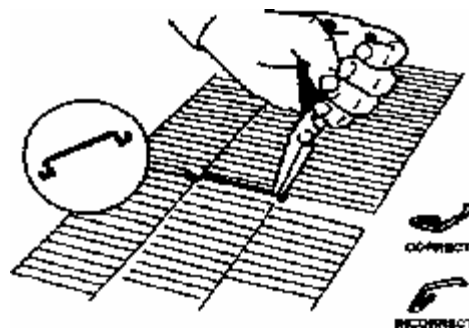

1. Locate connecting links on the conveyor belt, turn belt to place the links on the top left end of the conveyor approximately 8" (203mm) from the shaft.
2. You can easily remove the connecting links by grasping them with a pair of pliers and slipping the eye of the connecting link over the wire of the other links. Also notice the direction of the other links. The belt will have to be reinstalled with the opening facing the same way.
3. Carefully pull out the belt, rolling it up as you go. After you have it removed it may be placed in a pan of detergent solution to soak. Rinse with clean water.

CONVEYOR REASSEMBLY

Conveyor Belt Installation

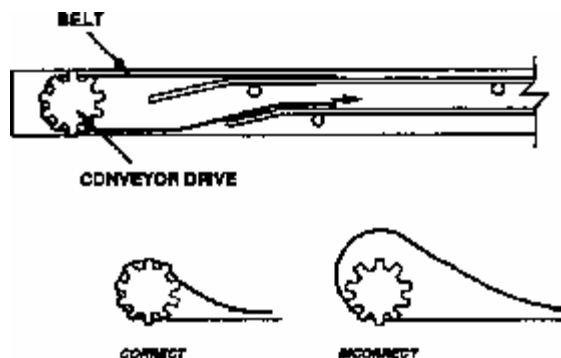

1. Put conveyor belt back on by setting the rolled belt to the left of the conveyor and thread approximately 2/3 of the belt over the bottom of the slider bed.
2. Put the loose end of the belt around the idler shaft and back on the conveyor. The belt must lay on top of the upper conveyor slider bed.
NOTE: The belt should curl around the conveyor sprockets and lay flat on top of the sprockets. If the belting does not curl around the sprockets and lay flat, remove the belting and turn over. Reinstall.
3. Pull all of the slack belt through the conveyor until both ends are on top of the conveyor on the left end.
4. Reconnect the conveyor belt by slipping the connecting links back in place.
NOTE: The conveyor belt of the Impinger DTF does not have a tension adjustment. If the belt would become too loose, a link(s) will have to be removed to tighten. A belt that is too tight will also cause operational problems due to excessive drag. We suggest that you have a qualified service person perform this adjustment.



WARNING:

Careful consideration should be exercised prior to removing a belt link because a belt that is too tight will impede the smooth operation of the conveyor.



CAUTION:

Do not work around conveyor belt with long hair, loose clothing or dangling jewelry. Getting caught in the belt could result in dismemberment or fatal injury.



CAUTION: BELT MAY BE HOT!

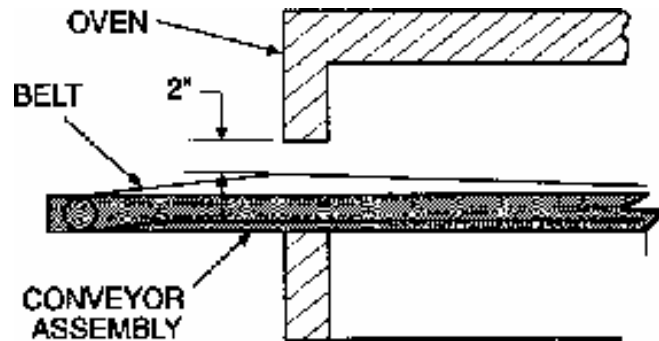

This page intentionally left blank.

GENERAL
MODEL 1980 SERIES

A	370515	Rubber Bumper
B	370593	Front Cover
C	370594	Front Element Cover
D	370713	Finger Housing, Bottom Right
E	370718	Columnating Panel
F	370703	Finger Cover
G	370450	¼ Turn Fastener
H	370717	Air Wash Assembly
I	370717	Air Wash Assembly
J	370703	Finger Cover
K	370718	Columnating Panel
L	370714	Finger Housing, Top Right
M	370619	Plenum Front
N	370597	Drive Shaft Cover
O	370598	Top Cover
P	370716	Finger Housing, Top Left
R	370718	Columnating Panel
S	370703	Finger Cover
T	370717	Air Wash Assembly
U	370717	Air Wash Assembly
V	370703	Finger Cover
W	370718	Columnating Panel
X	370715	Finger Housing, Bottom Left
Y	369373	Receptacle, Snap-In

GENERAL VIEW
MODEL 1980 SERIES

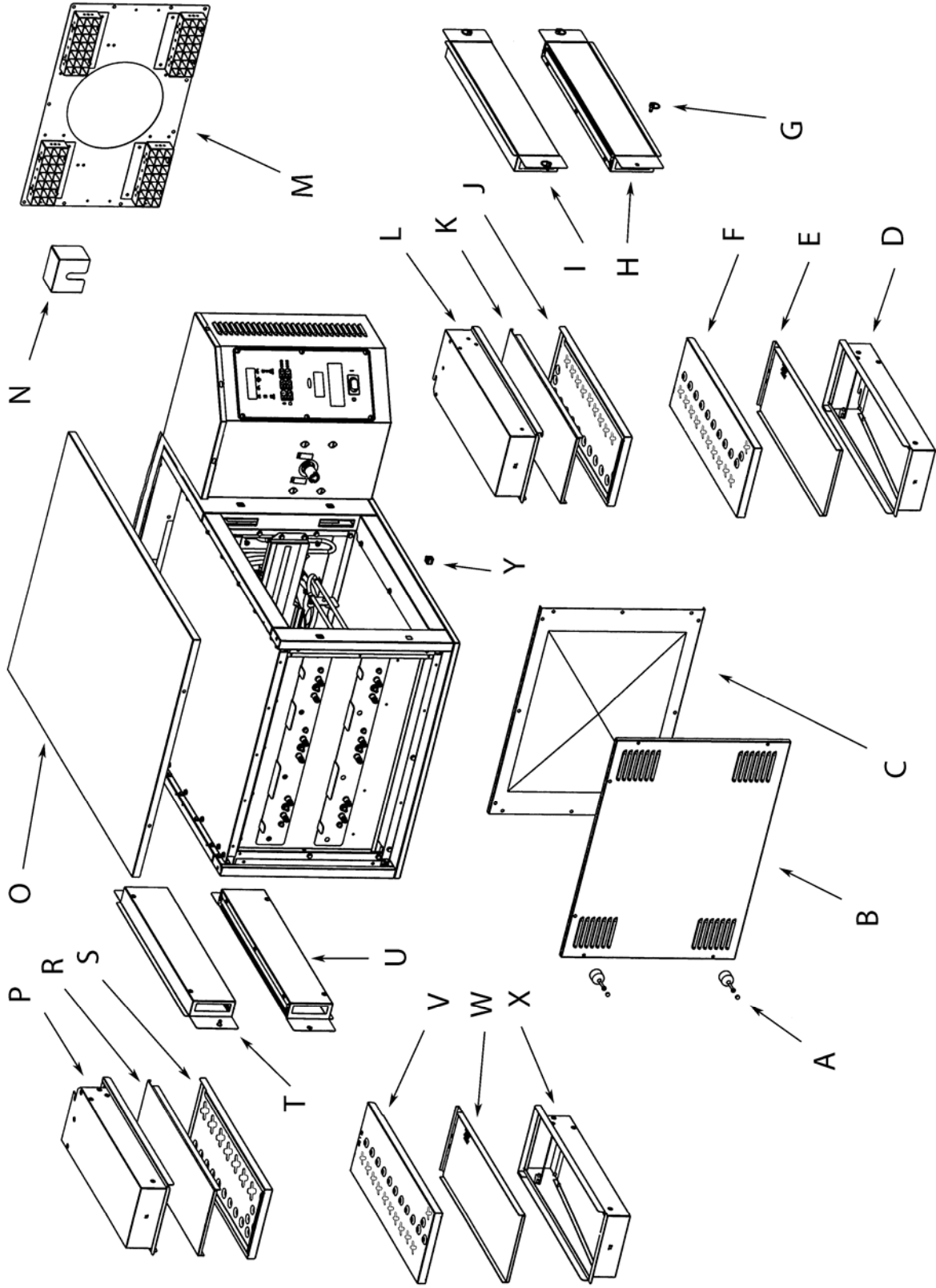

CONTROL BOX MODEL 1980 SERIES

A	369432	Switch, on/off
B	370573	Label, control panel
C	370599	Front panel
D	370571	Control, main and display
E	370383	Capacitor, conveyor motor
F	370519	Bracket, Motor
G	370600	Cover, rear control box
H	370462	Motor, conveyor
I	370601	Top, control box
J	370547	Gasket, Conveyor Motor
K	See Page 36	Heating element, Infrared (s/n 8001208 & below)
Not Shown	See Page 36	Heating element, Infrared (s/n 8001209 & above)
L	350259	Screw
M	370106	Washer
N	369413	Drive key
O	369460	Spring, compression
P	370671	Coupling sleeve

CONTROL BOX VIEW
MODEL 1980 SERIES

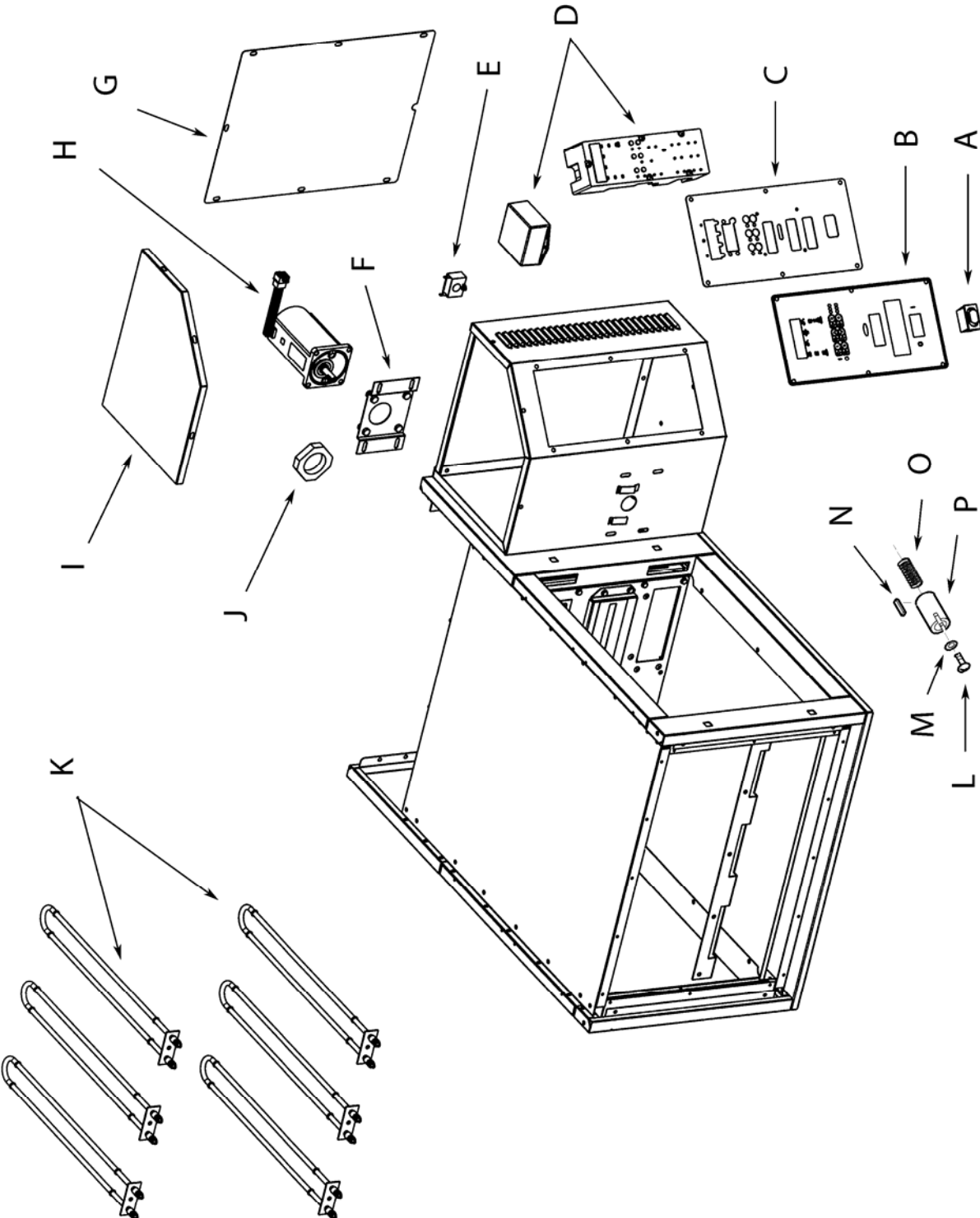

REAR VIEW MODEL 1980 SERIES

A	370704	Cover, Rear
B	370603	Cover, Heating Element
C	370618	Motor Mount
D	370604	Electrical Panel, RH
E	370603	Cover, Heating Element
F	370546	Fuse, 8A
G	370342	Fuse Holder
H	370551	IR Element Relay Assembly
Not Shown	370570	IR Element Relay (Relay Only)
I	369422	Relay, Main Fan
K	370515	Rubber Bumper
L	370569	Relay, Solid State
M	370582	Contactora, 3 Pole
N	370583	Power Cord
O	370693	Strain Relief (domestic models only)
	370694	Strain Relief (export models only)
P	370552	Reversing Switch, Conveyor
Q	369166	Fuse, 10A
R	369129	Fuse Holder
S	357067	Thermostat, Hi-Limit
T	369192	Capacitor
U	370576	Thermocouple
V	370577	Main Fan
Not Shown	See Page 37	Main Fan Element (s/n 8001208 & below)
Not Shown	See Page 37	Main Fan Element (s/n 8001209 & above)
Y	369427	Transformer, Control
Z	370466	Timer, Cool Down, 30 minute
AA	369422	Relay, Main Fan
BB	370606	Cooling Fan
CC	369033	Hose Clamp
DD	370607	Motor, Main Fan
EE	370605	Electrical Panel, LH

REAR VIEW
MODEL 1980 SERIES

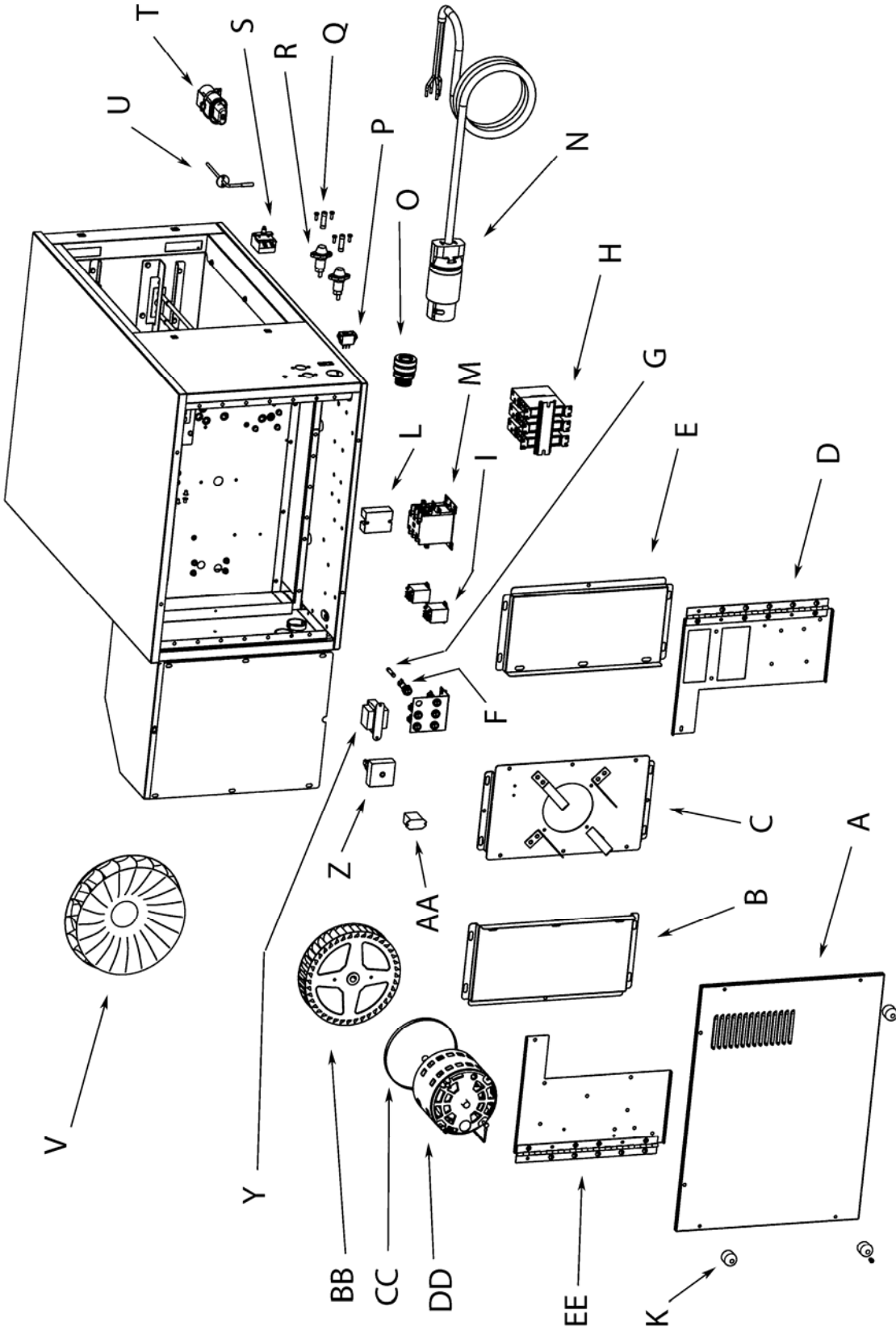

I.R. ELEMENTS VIEW
MODEL 1980 SERIES

S/N 8001209 AND ABOVE

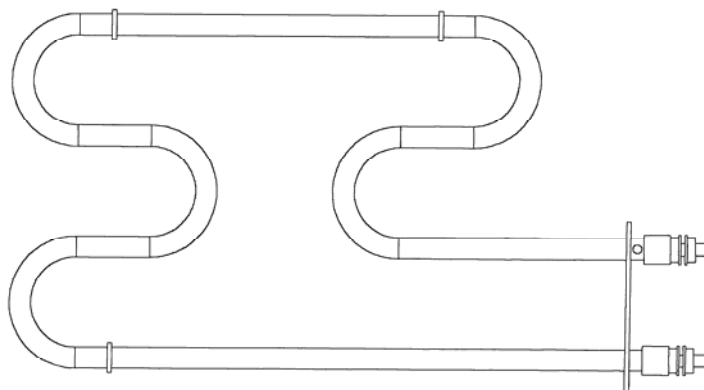

Model Description	Part Number
1981	370458
1982	370460
1982-000-E	370460
1983-000-E	370535
1984-000-E	370534
1984	370534

S/N 8001208 AND BELOW

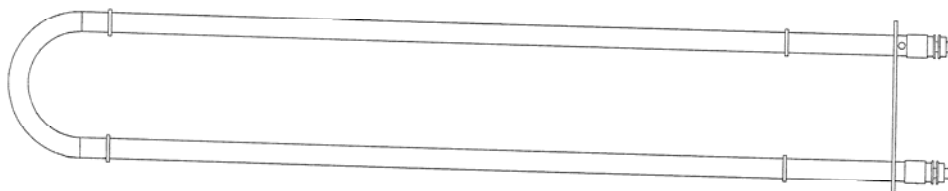

Model Description	Part Number
1981	370602
1982	370616

MAIN FAN ELEMENTS VIEW
MODEL 1980 SERIES

S/N 8001209 AND ABOVE

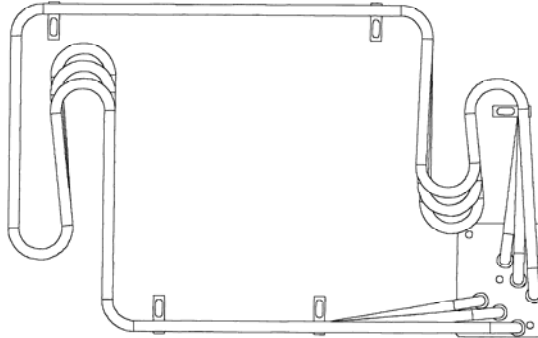

Model Description	Part Number
1981	370705
1982	370708
1982-000-E	370708
1983-000-E	370706
1984-000-E	370707
1984	370707

S/N 8001208 AND BELOW

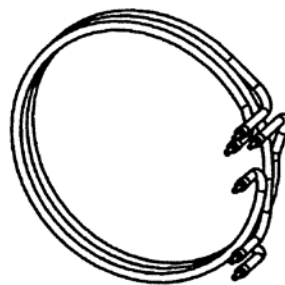

Model Description	Part Number
1981	370629
1982	370629

CONVEYOR MODEL 1980 SERIES

A	370477	Crumb pan, drive end
B	370478	Crumb pan, idle end
C	370480	Bracket, conveyor bearing
D	370526	Bushing, bearing retainer
E	370481	Flanged bearing, conveyor
F	370529	Conveyor frame
G	370650	Sprocket, idle
H	370509	Drive sprocket
I	370479	Conveyor belting
J	369952	Connecting links (three required)
K	370719	Pan stop, drive end
L	370720	Pan stop, idle end
M	370482	Shaft, idler
N	369471	Pin
O	370483	Shaft, drive
Not shown	370721	Conveyor assembly, complete

CONVEYOR VIEW MODEL 1980 SERIES

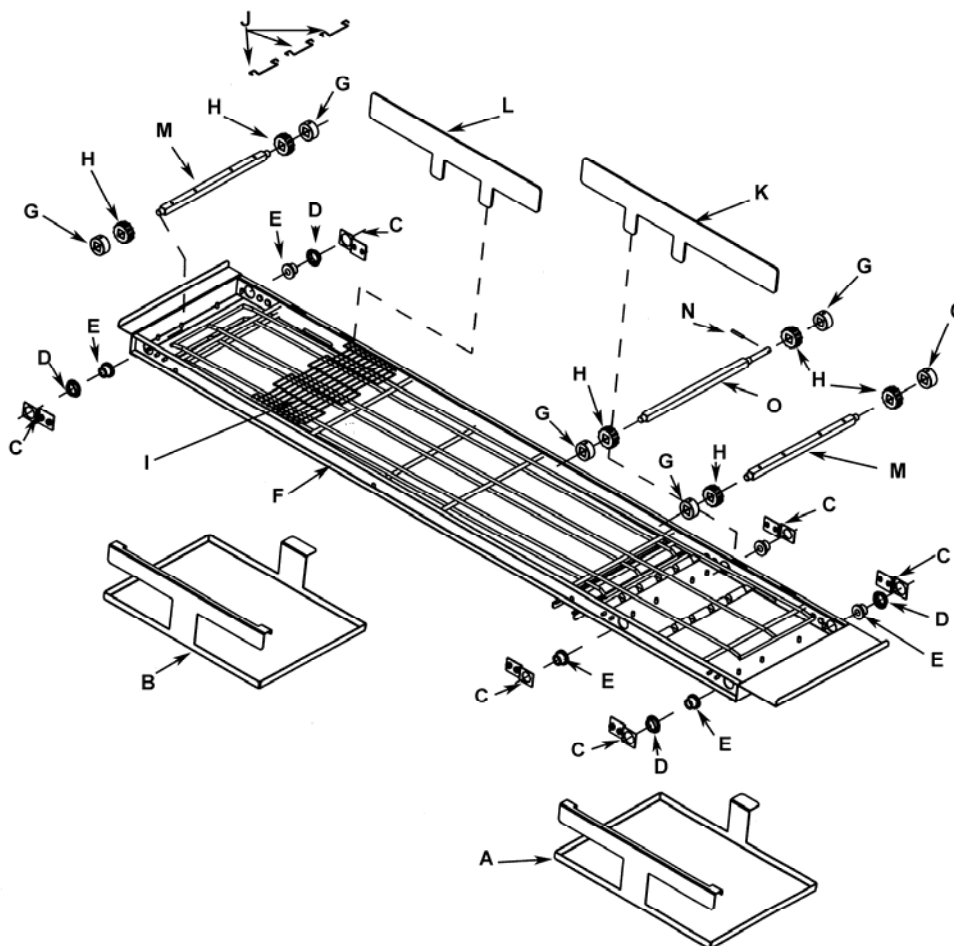

This page intentionally left blank.

This page intentionally left blank.

This page intentionally left blank.



Lincoln Foodservice Products, LLC
1111 North Hadley Road
Fort Wayne, Indiana 46804
United States of America

Telephone: (260) 459-8200
U.S. Fax: (888) 790-8193
Int'l Fax: (260) 436-0735

Service Hotline: (800) 678-9511

www.lincolnfp.com

