

**OPERATING • INSTALLATION • SERVICE
INSTRUCTIONS**

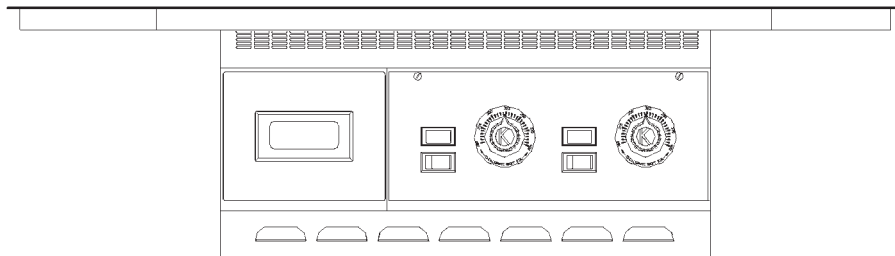

TEPPANYAKI GRIDDLE



1-800-KEATING
www.keatingofchicago.com

KEEP THIS MANUAL FOR TRAINING NEW PERSONNEL

TABLE OF CONTENTS

SECTION I INTRODUCTION

General	.1
Standard Features	.1
Model Variations	.1
Safety Precautions	.1

SECTION II INSTALLATION

Installation	.2
Damage During Shipment	.2
Positioning	.2
Leveling	.2
Electrical Connection	.2

SECTION III OPERATING THE GRIDDLE

Conditioning the Griddle	.2
Cooking	.2-3
Cleaning the Griddle	.3-4
Shutdown	.4

SECTION IV MAINTENANCE

Preventive Maintenance	.4
Calibration	.4
Griddle Surface	.5
Cleaning	.5

SECTION V SERVICE DIAGNOSIS

Trouble-Shooting Chart	.5
------------------------	----

SECTION VI PARTS LIST

Ordering Parts	.6
Warning and Operating Plates	.6
Teppanyaki Electric Griddle Control Panel	.6
Heating Element Assembly	.7

SECTION VII WIRING DIAGRAMS

Teppanyaki Griddle	.7
--------------------	----

NOTICE: This operating, installation, and service manual should be given to the user. The operator of the griddle should be familiar with the functions and operation of the griddle. This manual must be kept in a prominent, easily reachable location near the griddle.

NOTICE: Keating of Chicago, Inc. (manufacturer) reserves the right to change specifications at any time.

 <p>WARNING</p> <p>Improper installation can cause damage, injury or death.</p>	<p>WARNING</p> <p>IMPROPER INSTALLATION, ADJUSTMENT, ALTERATION, SERVICE OR MAINTENANCE CAN CAUSE PROPERTY DAMAGE, INJURY OR DEATH. READ THESE INSTALLATION, OPERATING AND MAINTENANCE INSTRUCTIONS THOROUGHLY BEFORE INSTALLING OR SERVICING THIS EQUIPMENT.</p>
---	---

 <p>WARNING</p> <p>Do not store flammable liquids near this or any other appliance.</p>	<p>FOR YOUR SAFETY</p> <p>DO NOT STORE OR USE GASOLINE OR OTHER FLAMMABLE VAPORS OR LIQUIDS IN THE VICINITY OF THIS OR ANY OTHER APPLIANCE.</p>
---	---

I INTRODUCTION

GENERAL

Keating MIRACLEAN® or polished steel Teppanyaki Griddles are designed to give maximum production efficiency, delivering high quality food products. The following design features are incorporated into Keating MIRACLEAN® or polished steel Teppanyaki Griddles.

STANDARD FEATURES

- MIRACLEAN® or polished steel energy efficient plate
- Baffled grease drawer with rear handle
- Stainless steel control panel

OPTIONS

- Welded stainless steel perimeter
- Front drain trough

STANDARD ACCESSORIES FOR MIRACLEAN® TEPPANYAKI GRIDDLE

- Keating griddle scraper
- Package of 10 scraper blades
- Keating Klenzer sample
- Palmetto Brush

STANDARD ACCESSORIES FOR POLISHED STEEL TEPPANYAKI GRIDDLE

- Keating Klenzer sample

ELECTRICAL

- All 230V = 1 Phase

MODEL VARIATIONS

Keating Teppanyaki Griddles can range in size from 24" (610mm) x 24" (610mm) to 72" (1829mm) x 30" (762mm). The actual heating surface on all sizes is 24"W (610mm) x 18"D (457mm).

SAFETY PRECAUTIONS

WARNING

THIS SYMBOL WARNS YOU THAT SERIOUS BURNS OR OTHER INJURIES MAY RESULT IF SAFETY INSTRUCTIONS ARE NOT FOLLOWED.

WARNING

THIS APPLIANCE MUST BE EARTHED.

- This service manual should be retained in a safe place for future reference.
- The installation of your new griddle must conform to local codes.
- Your ventilation hood, when installed, must conform to the current standard.
- Installation clearance requires 6" (152mm) from rear and side walls and supporting surfaces regardless of size of unit. 6"/152.4mm side clearance also required below the cooking surface.
- Adequate clearance for servicing and proper operation must be maintained. Your Keating MIRACLEAN® is designed to be serviced from the front, except for the rear field wire connections (electric input).
- Keating commercial griddles are intended for other than household use.
- ALWAYS instruct new employees on proper griddle operation.
- A MIRACLEAN® griddle should be operated ONLY by properly trained personnel.
- ALWAYS turn griddle off each night.
- ALWAYS disconnect electrical supply before servicing.
- NEVER leave a griddle unattended during operation.
- NEVER move griddle when hot.
- NEVER submerge in water.

THIS GRIDDLE MAY NOT BE ALTERED, MODIFIED OR CHANGED IN ANY WAY.



Safe operation of this equipment is possible only when the operating instructions and the safety precautions are read completely and the instructions are strictly observed. Before operating this equipment, ask for a practical demonstration.

Servicing should be performed by qualified and licensed service companies.

This unit is designed to be connected by fixed wiring only. Cords and plug caps are not acceptable. Electrical connection must be hard-wired by qualified personnel.

This is a fixed appliance and requires a disconnect on the fixed wiring with a contact separation of at least (3mm) in all poles. Power connection must remain accessible after installation.

NOTE: Only install in a non-combustible supporting surface.

II INSTALLATION

This unit must be installed, inspected, calibrated and serviced by qualified and/or certified and licensed personnel. Contact your dealer for assistance.

INSTALLATION

Installation must conform with local codes.

DAMAGE DURING SHIPMENT

The griddle has been assembled, tested and inspected at the factory. Upon arrival, the complete griddle should be checked for any damage that may have occurred during shipment.

What to do if equipment arrives damaged:

VISIBLE LOSS OR DAMAGE – Be certain to note this on the freight or express receipt and have it signed by the delivery person.

POSITIONING

The griddle must be placed under an exhaust hood with a fire retardant system. ALL connections and placements must comply with local and national codes. It is the responsibility of the owner and local installer to comply with these regulations when installing the griddle.

LEVELING

Your Teppanyaki Griddle will operate at its highest efficiency when properly leveled. The Teppanyaki griddle must be leveled within the table and the table must be leveled to the floor.

ELECTRICAL CONNECTION

The Teppanyaki Griddle is equipped with a three wire terminal block with ground for field wiring. Compare the griddle terminal connections with the wiring diagram on

page 7. This unit is designed to be connected by hard fixed wiring only. Cords and plug caps are not acceptable. Electrical connection must be hard-wired by qualified personnel.

WARNING

THIS APPLIANCE MUST BE EARTHED.

NOTE: NOT FOR OUTDOOR INSTALLATION.

NOTE: Customer must provide drawing of table that will be used, and table must be ventilated. Keating does not manufacture the table.

III OPERATING

CONDITIONING THE MIRACLEAN® GRIDDLE

The Teppanyaki Griddle plate has been “seasoned” at the factory. The chrome surface when heated creates a thin layer of chrome oxide which acts as a releasing agent for food products. If you feel you need to recondition the surface, the following instructions should be followed:

1. Follow cleaning instructions on page 3.
2. Heat the Teppanyaki to 400°F (204°C) for one hour.
3. Lower thermostat to 350°F (177°C), allowing the Teppanyaki to cool to about 350°F (177°C), as is evident when griddle cycles on or surface thermometer indicates desired temperature.
4. Lightly coat the Teppanyaki surface with griddle oil.

NOTE: Despite its food releasing properties, the chrome surface is not a true “non-stick” surface. For best cooking results and product appearance, use griddle oil for products that require the surface to be conditioned.

CONDITIONING THE POLISHED STEEL GRIDDLE

The surface of the polished steel griddle is conditioned by lightly coating the surface with griddle oil before each run of product.

COOKING

Follow cooking procedures below.

1. The actual heating section on all Teppanyaki griddles is 24”(610mm)x18”(457mm). The heating section is located in the center front of the griddle.

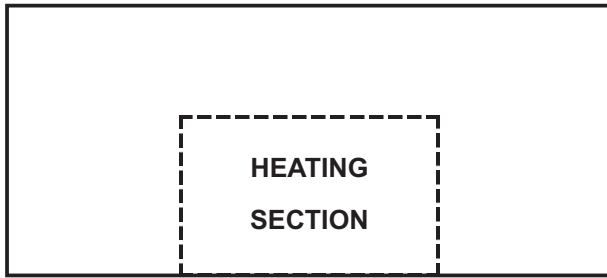

NOTE: Because of the superior heating characteristics and heat retention properties found in the Teppanyaki Griddle, operating temperatures should be set 10°F to 25°F (6°C to 14°C) below conventional griddles.

- Set the thermostat to the desired temperature and wait ten minutes for preheating.
- See figure 3-1 for proper food placement. The thermostat sensing bulbs are located below the plate.
- Load the product to the left and right of each sensing bulb, then fill the area above the thermostat sensing bulb. See figure 3-1.

Figure 3-1
Sample configuration of proper food placement

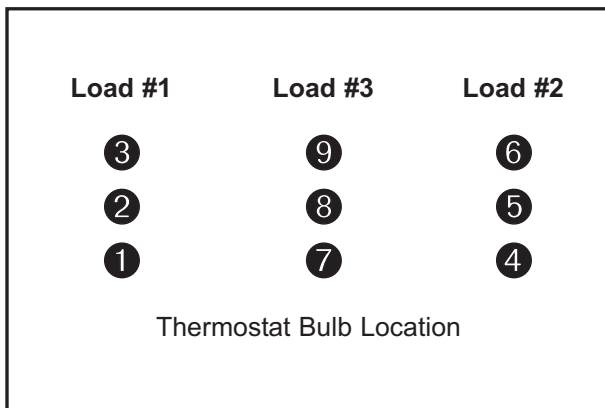

If you cook over the sensing bulb only, you are drawing heat from that section, activating the thermostat to call for more heat even though the area around it is still at the temperature setting. This will result in higher surface temperatures which will affect your cooking and product appearance.

Figure 3-2
Top view placement of elements under Teppanyaki Griddle plate.

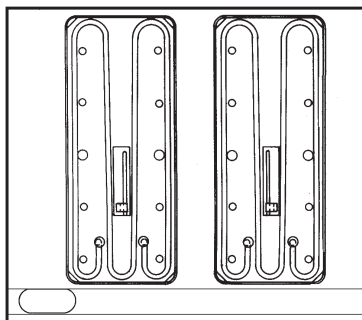

- After each load, scrape the griddle surface completely clean using the 4" (102mm) wide replaceable blade scraper.

CAUTION

DO NOT HACK, CHOP, HIT OR CUT ON THE TEPPANYAKI SURFACE. You will dent the steel plate under the trivalent chrome. It is even possible to hack two nicks close together and actually tear the Teppanyaki surface as the chromium will not stretch. Below is a sketch showing the side view of a griddle plate and how the surface can be damaged.

Figure 3-3
Surface Damage

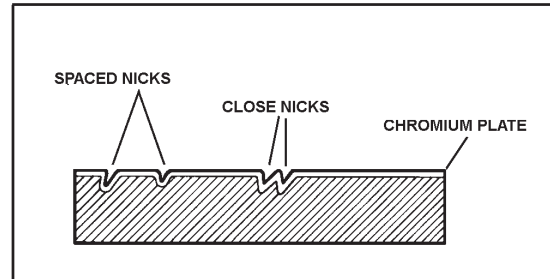

Never use griddle scraper on the polished steel Teppanyaki Griddle. This will damage the surface.

CAUTION

Damage done to the Teppanyaki surface is irreparable.

CLEANING THE MIRACLEAN® GRIDDLE

The surface of the Teppanyaki Griddle is very durable and with proper care, following the procedures below, will last many years.

A sample of Keating Klenzer and a 4" (102mm) scraper are included with each new Miraclean® griddle.

- Scrape Teppanyaki surface with the Keating scraper.

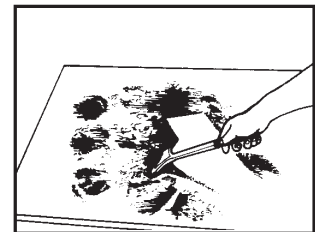

- Clean with potable tap water and a palmetto brush.

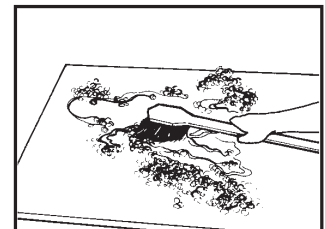

- Polish surface with USDA certified Keating Klenzer. Rinse with potable water to remove excess Keating Klenzer.

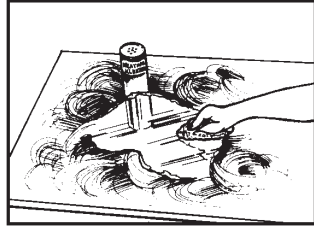

⚠ WARNING

BECAUSE OF THE SUPERIOR TEPPANYAKI MIRACLEAN® SURFACE, THE ONLY TOOLS YOU WILL EVER NEED TO CLEAN THE GRIDDLE ARE A PALMETTO BRUSH AND A KEATING SCRAPER.

- **NEVER USE A GRIDDLE STONE, BRICK OR SCREEN TO CLEAN THE TEPPANYAKI MIRACLEAN® SURFACE.**
- **DAMAGE DONE TO THE TEPPANYAKI SURFACE BY GRIDDLE STONE, BRICK OR SCREEN WILL VOID THE WARRANTY.**
- **THE DAMAGE DONE TO THE TEPPANYAKI SURFACE IS IRREPARABLE.**
- **NEVER USE ICE TO COOL THE TEPPANYAKI SURFACE. USE OF ICE MAY WARP THE TEPPANYAKI SURFACE.**
- **USE ONLY KEATING SUPPLIED CLEANING TOOLS AND KLENZER.**

CLEANING POLISHED STEEL SURFACE

To clean polished steel surface use griddle stone or screen with Keating Klenzer. Rinse with potable water to remove excess Keating Klenzer. Put a light coating of oil on the polished steel surface to prevent rusting.

SHUTDOWN

Turn each thermostat fully counterclockwise to “OFF” position.

IV MAINTENANCE

PREVENTIVE MAINTENANCE

Following preventive maintenance procedures will help keep your Teppanyaki working efficiently. Proper care and servicing will lead to years of quality performance.

PREVENTIVE MAINTENANCE CHART

TIME FRAME	OPERATOR/OWNER	SECTION
Daily	<ul style="list-style-type: none"> ● Check controls. ● Clean griddle surface. ● Drain and clean grease drawer. ● Completely wipe down griddle cabinet. 	III
Monthly*	<ul style="list-style-type: none"> ● Check condition of Teppanyaki surface and review proper cleaning procedures. ● Check calibration of thermostat(s). ● Review installation and operating instructions received with griddle. 	III IV II
Yearly*	<ul style="list-style-type: none"> ● Have griddle completely checked, calibrated, tested, cleaned, etc. by qualified service personnel. 	

*High production facilities should be checked more often.

CALIBRATION

Tools: Accurate surface thermometer
Standard screwdriver

- Turn on the griddle with thermostat set at 300°F(149°C). Allow elements to cycle on and off three times. (Approximately 10 minutes.)
- Place thermometer on surface over thermostat bulb. The thermostat bulb is approximately 2/3 to 3/4 of the way straight back to the rear of the griddle.
- When elements cycle off, the griddle is up to temperature. If temperature is within 15°F(10°C) of thermostat setting, remove knob. Loosen two screws in the thermostat dial.
- Replace knob. Turn dial plate until temperature matches thermometer.
- Remove knob. Tighten screws on dial plate. Replace knob.

For calibration over a 15° difference, contact your local service distributor.

CLEANING

Proper care should be taken to fully clean the griddle on a regular basis..

DISCONNECT ELECTRIC POWER SOURCE BEFORE CLEANING.

CONTROL PANEL - Clean any grease build-up on the thermostat knobs.

NOTE: If grease gets into the body of the thermostat, it may cause it to fail.

**IF GREASE GETS INTO THE BODY OF THE THERMOSTAT,
IT MAY CAUSE POSSIBLE ELECTRICAL SHOCK.**

V SERVICE DIAGNOSIS

A. Trouble-Shooting

The following diagnosis is only to be used as a guide to qualified service personnel. Keating recommends that you use a qualified service company.

PROBLEM	PROBABLE CAUSE	SOLUTION
Griddle won't heat.	<ul style="list-style-type: none">a. No electricity to griddle.b. Thermostat isn't on.c. Thermostat is faulty.d. Connections are loose.e. Element is faulty.	<ul style="list-style-type: none">a. Connect griddle to an approved source of power.b. Turn thermostat to desired cooking temperature.c. Replace thermostat.d. Tighten connections.e. Replace element.
Temperature of griddle is erratic.	<ul style="list-style-type: none">a. Thermostat out of calibration.b. Thermostat bulb improperly placed.c. Exhaust problems or drafts.	<ul style="list-style-type: none">a. Calibrate thermostat. See page 4—Calibration.b. Adjust thermostat bulb.c. Contact your HVAC representative.
Griddle is overheating.	<ul style="list-style-type: none">a. Thermostat out of calibration.b. Thermostat is faulty.	<ul style="list-style-type: none">a. Calibrate thermostat.b. Replace thermostat.

VI PARTS LIST

ORDERING PARTS

Parts may be ordered by part number by calling Keating at 1-800-KEATING or your service company. You may also order online at Keating's part store, www.keatingofchicago.com.

The model/serial plate is located on the control panel assembly. The serial and model numbers are necessary when ordering.

WARNING AND OPERATING PLATES

All warning and operating plates on the Keating Teppanyaki Electric Griddle should be in place at all times. If plates are damaged or lost, replace them immediately.

TEPPANYAKI ELECTRIC GRIDDLE CONTROL PANEL

Figure 6-1

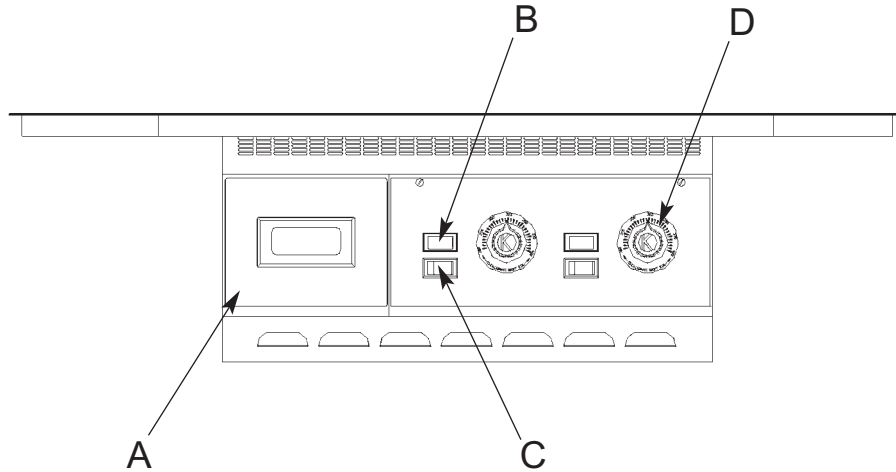

	Part No.	Description
A	052505	Grease Drawer
B	050255	Light
C	054920	Switch
D	029521	Thermostat 550°
	058038	Thermostat Dial Plate 550°
	009914	Thermostat Knob 550°

HEATING ELEMENT ASSEMBLY

Figure 6-2

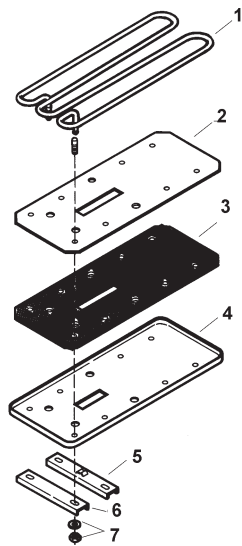

ITEM	DESCRIPTION	PART NUMBER
1	HEATING ELEMENT 3.3kW, 220V	002482
	HEATING ELEMENT 3.3kW, 380V	006335
	HEATING ELEMENT 3.3kW, 415V	012084
	HEATING ELEMENT 3.3kW, 480V	005567
2	HEATING ELEMENT PAN 24"(610mm)	020553
3	INSULATION BOARD 24"(610mm)	002489
4	HEAT DISPERSION PLATE 24"(610mm)	005913
5	HEATING ELEMENT BULB HOLD DOWN "M" BRACKET	008593
6	HEATING ELEMENT HOLD DOWN BRACKET	029352
7	3/8"(9.525mm) NUT, WASHER, LOCK-WASHER AND PALNUT	028736
	Items 6 & 7 as a kit	029352

VII WIRING DIAGRAM

A wiring diagram is mounted inside the control panel of every griddle. See your individual piece of equipment for specific diagram.



WARRANTY

LIMITED WARRANTY

Keating Of Chicago, Inc. ("Keating") warrants to the original purchaser. ("Customer"), all new Keating Fryers, Filter Systems, Griddles, Keep Krisp[®], Custom Pasta Systems, Top-Side[™] Cookers, Computer Timers, Fryer & Pasta Vessels, and Keating replacement parts ("products") installed after June 1, 1994 to be free to defects in material or workmanship, subject to the following terms and conditions.

LENGTH OF WARRANTY

All products other than Fryer & Pasta Vessels and replacement parts shall be warranted for a period of one year from the date of original equipment installation. Keating replacement parts are warranted for a period of ninety days from the date of installation. Fryer & Pasta Vessels are warranted as described below.

FRYER & PASTA VESSEL WARRANTY

Fryers purchased after June 1, 1994 carry a prorated vessel warranty on defects in materials or workmanship to the Customer based on the following scale:

Time from Installation Date	Fryer Vessel Warranty Credit
13-60 months	100%
61-72 months	80%
73-84 months	60%
85-96 months	40%
97-108 months	20%
109-120 months	10%

The credit for the defective fryer & pasta vessel shall be applied against the cost of the replacement vessel, utilizing Keating's then current price, upon return of the vessel to Keating. (Freight to be paid by Keating within the first 2 months only), only during the first 60 months as described above, subject to the limitations described below.

LIMITATIONS OF LIABILITY

In the event of warranty claim or otherwise, the sole obligation of Keating shall be the repair and/or replacement at the option of Keating of the product or part thereof. Such repair or replacement shall be at the expense of Keating except that the Customer shall pay the following expenses: all freight and labor expense for Keating replacement parts for all other products, mileage exceeding 50 miles or travel more than one hour, labor costs of more than one person, overtime rates, truck charges, difference between ground and other mode of transportation, and holiday charges. Any repair or replacement under this Limited Warranty does not constitute an extension of the original warranty for any period for the product or for any component or part thereof. Parts to be replaced under this Limited Warranty will be repaired at the option of Keating with new or functionally operative parts. Keep Krisps and Computer Timers must be returned to Keating for warranty repair or replacement. Field repairs of those items are not authorized.

THE LIABILITY OF KEATING ON ANY CLAIM OF ANY KIND, INCLUDING CLAIMS BASED ON WARRANTY, EXPRESSED OR IMPLIED, CONTRACT, NEGLIGENCE, STRICT LIABILITY OR ANY OTHER THEORIES SHALL BE SOLELY AND EXCLUSIVELY THE REPAIR OR REPLACEMENT OF THE PRODUCT AS STATED HEREIN, AND SUCH LIABILITY SHALL NOT INCLUDE, AND CUSTOMER SPECIFICALLY RENOUNCES ANY RIGHTS TO RECOVER, SPECIAL, INCIDENTAL, CONSEQUENTIAL OR OTHER INJURIES TO PERSONS OR DAMAGE TO PROPERTY, LOSS OF PROFITS OR ANTICIPATED PROFITS, OR LOSS OF USE OF THE PRODUCT.

If any oral statements have been made regarding the Keating products, such statements do not constitute warranties and are not part of the contract sale. This Limited Warranty constitutes the complete, final and exclusive statement with regard to warranties.

THIS LIMITED WARRANTY IS EXCLUSIVE AND IS IN LIEU OF ALL OTHER WARRANTIES WHETHER WRITTEN, ORAL, STATUTORY OR IMPLIED, INCLUDING BUT NOT LIMITED TO ANY WARRANTY OF MERCHANTABILITY OR FITNESS FOR PARTICULAR PURPOSE OR WARRANTY AGAINST LATENT DEFECTS.

EXCLUSIONS

The warranties provided by Keating of Chicago, Inc. do not apply in the following instances:

1. Defects arising out of or resulting from improper installation or maintenance, abuse, misuse, modification or alteration by unauthorized service personnel, or any other condition not attributable to a defect in material or workmanship. Proper installation and maintenance are the responsibility of the installer and Customer, respectively. Proper installation and maintenance procedures are prescribed by the Keating Service Manual.
2. In the event that the product was damaged after leaving the factory due to flood, fire, other acts of God or accident, damage during shipment should be reported to the carrier and is not the responsibility of Keating.
3. In the event the serial number or rating plate has been removed from the product or altered.
4. On parts which would normally be worn or replaced under normal conditions, including but not limited to electric bulbs, fuses, interior and exterior finishes, gaskets and radiants.
5. With regard to adjustments and calibrations such as leveling, tightening of fasteners or plumbing connections, improper gas pressure or improper electrical supply, the checking of and changes in adjustment and calibrations are the responsibility of the installer. Proper installation procedures are prescribed by the Keating Service Manual.
6. In the event of unauthorized repairs or alterations to the Keating product.
7. With the use of sodium chloride in pasta vessels or harsh chemicals in fryer or pasta vessels.

OTHER TERMS AND CONDITIONS

The Customer must provide proof of purchase from Keating.

This Limited Warranty is valid in the 50 United States, its territories, and Canada, and is void elsewhere.

Keating products are sold for commercial use only. If any Keating product is sold as a component of another product or used as a consumer product, such Keating product is sold As Is without any warranty. If any provision of this Limited Warranty is held to be unenforceable under the law of any jurisdiction, such provision shall be inapplicable in such jurisdiction, and the remainder of the warranty shall remain unaffected. Further in such event, the maximum exclusion or limitation allowable under applicable law shall be deemed substituted for the unenforceable provision. This Limited Warranty shall be governed by and construed in accordance with the laws of the State of Illinois.

TO SECURE WARRANTY SERVICE

All repair services under this Limited Warranty must be authorized by Keating or performed at Keating. Authorization may be obtained by calling 1-800-KEATING within the Continental United States, Alaska, Hawaii, Puerto Rico and Canada during normal business hours (7:00 a.m. through 6:00 p.m. Central Time, Monday through Friday). When calling, please have the following information available: (1) name, address and telephone number of the Customer; (2) location of product; (3) name, model number and serial number of the product; (4) installation date; and (5) description of defect. Keating will then issue a service authorization work order number to one of its approved independent servicing organizations, or request the product or part be shipped to Keating for repair or replacement, as appropriate. Any defective part subject to a claim under this Limited Warranty must be shipped freight prepaid and examination. Keating's decision as to the cause and nature of any defect under this Limited Warranty shall be final.

KEATING

KEATING OF CHICAGO, INC., 1-800-KEATING WWW.KEATINGOFCHICAGO.COM

SERVICE INFORMATION

If you have a service related question call 1-800-KEATING.

Please state the nature of the call; it will ensure speaking with the appropriate person.

Have your serial and model number available when ordering parts.

KEATING OF CHICAGO, INC.

8901 W. 50th Street, McCook, Illinois 60525-6001

Phone: (708) 246-3000 FAX: (708) 246-3100

Toll Free 1-800-KEATING (In U.S. and Canada)

www.keatingofchicago.com

***As continuous product improvement occurs, specifications may be changed without notice.**

KEATING LIMITED WARRANTY CARD

PLEASE COMPLETE AND MAIL AT ONCE--WARRANTY IS NOT IN EFFECT UNTIL CARD IS RETURNED

COMPANY: _____

ADDRESS: _____

CITY: _____ STATE: _____ ZIP: _____

DEALER: _____

DATE OF PURCHASE: _____ INVOICE NUMBER: _____

SERIAL NUMBER: _____ FRYER FILTER SYSTEM GRIDDLE

REMARKS: _____ TOP-SIDE COOKER HOT PLATE PASTA PLUS

I HAVE READ THE INSTALLATION AND OPERATION INSTRUCTIONS.

SIGNED: _____ DATE: _____

"Serving Those Who Serve The Very Best"