



"Serving Those Who Serve The Very Best"®

MIRACLEAN® 2000 ELECTRIC GRIDDLE

INSTALLATION MANUAL USER OPERATION and MAINTENANCE SERVICE INSTRUCCIONES

READ AND SAVE THIS MANUAL FOR FUTURE REFERENCE

Record the Model No. and Serial No. of this Miraclean® Griddle in the space provided below.

Serial No. _____

Model No. _____

Keep these numbers for future reference.

IMPORTANT: Keep a copy of your bill of sale. The date on the bill establishes the warranty period should service be required. If service is performed, it is in your best interest to obtain and keep all receipts.

CONTENTS

General	1	Griddle Surface	6
Standard Features	1	Limited Calibration.....	6
Model Variations.....	1	Trouble Shooting Chart	7
Safety Precautions.....	1	Ordering Parts	8
Installation	2	Warning and Operating Plates	8
Damage During Shipment.....	2	Miraclean® Electric Griddle Assembly	8-9
Positioning	2	Heating Element Assembly	9
Leveling.....	2	Wiring Diagram.....	10
Restraining Devices.....	2	27"-30" Wide Electric Griddles	11
Electrical Connection	3	36" & 42"-48" Wide Electric Griddles	12
Conditioning the Griddle.....	3	60" & 72" Wide Electric Griddles	13
Cooking	3-4	24" Deep Models	11
Cleaning the Griddle	5	30" Deep Models	12
Shutdown	5	36" Deep Models	13
Warranty Repairs	5		
Preventive Maintenance	5		

This Owner's Guide provides specific operating instructions for your model.

Versión en español

Si desea obtener una copia en español de este Manual del Usuario, sírvase escribir a la dirección que se incluye a continuación.

***As continuous product improvement occurs, specifications may be changed without notice.**

1-800-KEATING

www.keatingofchicago.com



POST THIS LABEL IN A PROMINENT LOCATION ON YOUR UNIT.

<p>⚠ WARNING</p>  <p>Do not store flammable liquids near this or any other appliance.</p>	<p>⚠ WARNING</p> <p>DO NOT STORE OR USE GASOLINE OR OTHER FLAMMABLE VAPORS OR LIQUIDS IN THE VICINITY OF THIS OR ANY OTHER APPLIANCE.</p>
---	--

<p>⚠ WARNING</p>  <p>Improper installation can cause damage, injury or death.</p>	<p>⚠ WARNING</p> <p>IMPROPER INSTALLATION, ADJUSTMENT, ALTERATION, SERVICE OR MAINTENANCE CAN CAUSE PROPERTY DAMAGE, INJURY OR DEATH. READ THE INSTALLATION, OPERATING AND MAINTENANCE INSTRUCTIONS THOROUGHLY BEFORE INSTALLING OR SERVICING THIS EQUIPMENT.</p>
---	--

INTRODUCTION

GENERAL

Keating MIRACLEAN® Electric Griddles are designed to give maximum production efficiency, delivering high quality food products. The following design features are incorporated into Keating MIRACLEAN® Electric Griddles.

STANDARD FEATURES

- MIRACLEAN® energy efficient plate
- Welded stainless steel perimeter
- Welded stainless steel grease trough
- Baffle grease drawer with rear handle
- Stainless steel control panel

STANDARD ACCESSORIES

- Keating griddle scraper
- Package of 10 scraper blades
- Palmetto brush
- 4" special Keating spatula
- Keating egg turner
- Keating Klenzer sample

OPTIONS

- 380 or 480 volt input
- Single phase input
- High input heating elements

MODEL VARIATION

Standard Griddles: Keating MIRACLEAN® electric griddles are available in widths ranging from 24" to 72" and in 24", 30" and 36" depths. The electric griddles are ETL listed.

SAFETY PRECAUTIONS

WARNING

THIS SYMBOL WARNS YOU THAT SERIOUS BURNS OR OTHER INJURIES MAY RESULT IF SAFETY INSTRUCTIONS ARE NOT FOLLOWED.

- This service manual should be retained in a safe place for future reference.
- The installation of your new griddle must conform to local codes or in the absence of local codes, with the current National Electrical Code ANSI/NFPA 70 or Canadian Electrical Code CAN 22.2 as applicable.
- Your ventilation hood, when installed, must conform to the current ANSI/NFPA 96 standard.
- Installation clearance requires 6" from rear and side walls.
- You must maintain this appliance free and clear from combustibles.
- Adequate clearance for servicing and proper operation must be maintained.
- Your Keating MIRACLEAN® is designed to be serviced from the front, except for the rear field wire connections (electric input).
- Keating commercial griddles are intended for other than household use.
- ALWAYS instruct new employees on proper griddle operation.
- A MIRACLEAN® griddle should be operated ONLY by properly trained personnel.
- ALWAYS turn griddle off each night.
- ALWAYS disconnect electrical supply before servicing.
- NEVER leave a griddle unattended during operation.
- NEVER move griddle when hot.



THIS GRIDDLE MAY NOT BE ALTERED, MODIFIED OR CHANGED IN ANYWAY.

Safe operation of this equipment is possible only when the operating instructions and the safety precautions are read completely and the instructions contained therein are strictly observed. Before operating this equipment, ask for a practical demonstration.



Periodically inspect cable and plug, if provided, before using machine. Servicing should be performed by qualified and licensed service companies.

II INSTALLATION

This unit must be installed, inspected, calibrated and serviced by qualified and/or certified and licensed service personnel - you may void your Keating warranty if installation is not completed per local, national and Keating specifications. Contact your dealer for assistance.

INSTALLATION

Installation must conform with local codes or, in absence of local codes, with the current National Electrical Code ANSI/NFPA 70 or Canadian Electrical Code CAN22.2 as applicable.

DAMAGE DURING SHIPMENT

The griddle has been assembled, tested and inspected at the factory. Upon arrival, the complete griddle should be checked for any damage that may have occurred during shipment.

The carrier is responsible for all damage in transit whether visible or concealed. Do not pay the freight bill until the griddle has been thoroughly checked for damage. If concealed damage is found later, contact the carrier immediately to file a claim.

What to do if equipment arrives damaged:

VISIBLE LOSS OR DAMAGE -- Be certain to note this on the freight or express receipt and have it signed by the delivery person.

FILE CLAIM FOR DAMAGES IMMEDIATELY -- Regardless of extent of damage.

CONCEALED LOSS OR DAMAGE -- If damage is noticed when equipment is unpacked, notify the freight company immediately, and file a "concealed damage claim". This **MUST** be done immediately. Be sure to retain the shipping container for inspection.

Keating does not assume responsibility for Loss or Damage incurred in transit.

POSITIONING

The griddle must be placed under an exhaust hood with a fire retardant system. Your ventilation hood, when installed, must conform to the current ANSI/NFPA 96 standard. ALL connections and placement must comply with local and national codes. It is the responsibility of the owner and local installer to comply with these regulations when installing the griddle.

NOTE: NOT FOR OUTDOOR INSTALLATION

LEVELING

Your MIRACLEAN® Griddle will operate at its highest efficiency when properly leveled. Place a level on the griddle plate from side to side. For griddles on legs, the bottom foot of the leg is adjustable. Turn clockwise to decrease height or counterclockwise to increase height until level. For griddles on stands with casters, the casters are adjustable by loosening the jam nut and turning the caster in or out. When the desired level is reached, tighten the jam nut. Adjustments of more than 3/4" are not recommended on any caster. The same procedure should be followed to the level the griddle from front to back.

Figure 2-1

Leveling Griddle

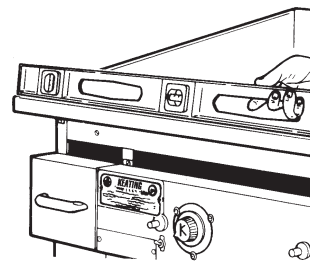

RESTRAINING

For griddle installations on stands with casters, casters and jam nuts must be completely tightened. Adequate means must also be provided to limit the movement of the appliance.

The restraint must be attached to the rear of the griddle as close as possible to the center line width and the bottom of the cabinet back to allow the restraining bolt to be anchored to the cabinet back between the cabinet bottom and inner liner to ensure positive support to restrain griddle movement.



IF DISCONNECTION OF THE RESTRAINT IS NECESSARY, IT MUST BE RECONNECTED WHEN THE MIRACLEAN® GRIDDLE IS RETURNED TO ITS ORIGINALLY INSTALLED POSITION.

ELECTRICAL CONNECTION

The Keating Electric MIRACLEAN® Griddle is equipped with a three wire terminal block for customer connections. Compare the griddle terminal connections to the appropriate wiring diagram for the griddle (see page 10 - Wiring Diagram) to see if the griddle is connected three phase or single phase. All wires, cords, plugs, receptacles and circuit breakers must be sized adequately for the full load rating of the griddle as specified by local codes or, in the absence of local codes, by the current National Electrical Code ANSI/NFPA 70 or the Canadian Electrical Code CAN 22.2 as applicable.

The Electric MIRACLEAN® Griddle is also equipped with a grounding lug next to the terminal block. For proper grounding procedures, see local codes or, in the absence of local codes, the current National Electrical Code ANSI/NFPA 70 or the Canadian Electrical Code CAN 22.2 as applicable.

NOTE: The connections to the griddle can be changed in the field from three phase to single phase or from single phase to three phase. This can be done by simply changing the wiring at the terminal block. To change the connections for your griddle, see the wiring diagram for your griddle on page 10.

NOTE: For griddles rated at 208-240 volts, the amperage ratings marked on the nameplates of the griddles are listed at 240 volts as required by UL. If your griddle uses a 208 or 220 volt system, refer to the Electric Griddle Specifications on pages 11 to 13 to determine the full load rating of the griddle.

NOTE: A hole has been punched in the rear of the griddle cabinet for a cord or conduit exit. If a cord is used, the National Electrical Code, UL standards and most local codes require a bushing or strain relief (not provided by Keating) to protect the cord.

III OPERATING

CONDITIONING THE GRIDDLE

The MIRACLEAN® Griddle plate has been “seasoned” at the factory. The chrome surface when heated creates a thin layer of chrome oxide which acts as a releasing agent for food products. If you feel you need to recondition the surface, the following instructions should be followed:

1. Follow cleaning instructions on page 5.
2. Heat the MIRACLEAN® to 400°F for one hour.
3. Lower thermostat to 350°F, allowing the MIRACLEAN® to cool to about 350°F, as is evident when griddle cycles on or surface thermometer indicates correct temperature.
4. Lightly coat the MIRACLEAN® surface with griddle oil.

NOTE: Despite the food releasing properties, the chrome surface is not a true “non-stick” surface. For best cooking results and product appearance, use griddle oil for products that require the surface to be conditioned.

COOKING

Keating MIRACLEAN® Griddles are designed to provide maximum production efficiency and deliver high quality food products. Follow cooking procedures below.

1. Set ON/OFF switch to “ON” position. The Power indicating light will illuminate.
2. Set the thermostat to the desired temperature and wait approximately ten minutes for preheating. Recommended cooking temperatures for various food products are as follows:

RECOMMENDED COOKING TEMPERATURES	
PRODUCT	°F
Eggs	250°F
Bacon	325°F
Sausage (patty or link)	325°F
Hash Browns	350°F
French Toast	350°F
Wheat Cakes	360°F
Hamburgers – 2/lb. (8oz.)	325°F
4/lb. (4 oz)	315°F
10/lb. (1.6oz)	310°F
Grilled Cheese	325°F
Chicken Breasts (skinless)	350°F
Hot Dogs – 45g each	310°F
57g each	310°F
Salmon Filet	325°F
Salmon Steaks	325°F
Buns/Breads (toasting) 30 seconds max.	375°F

NOTE: Because of the superior heating characteristics and heat retention properties found in the MIRACLEAN® Griddle, operating temperatures should be set 10°F to 25°F below conventional griddles.

- Locate the inverted “V’s” on the front of the griddle cooking plate. Depending on your model you may have from one to six thermostats. The “V’s” indicate where the thermostat sensing bulbs are located below the plate.
- Load the product to the left and right of each inverted “V” first, then fill the area above the thermostat sensing bulb. See figure 3-1 below.

Figure 3-1

Sample configuration of proper food placement

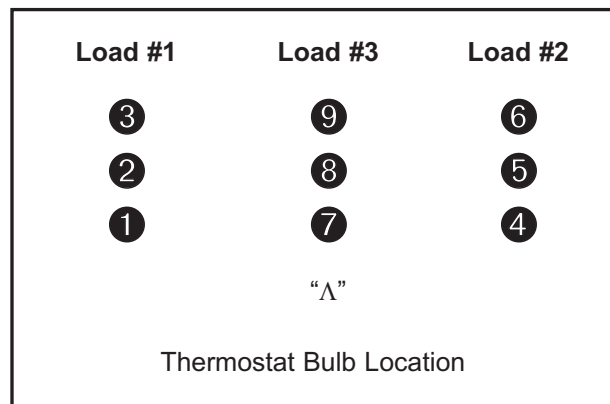

If you cook over the sensing bulb only, you are drawing heat from that section, activating the thermostat to call for more heat even though the area around it is still at the temperature setting. This will result in higher surface temperatures which will affect your cooking and product appearance.

Figure 3-2

Top view placement of elements under MIRACLEAN plate.

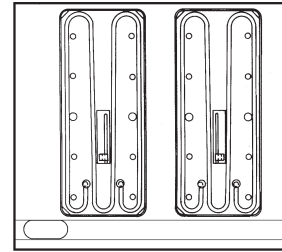

- After each load, scrape the griddle surface completely clean using the 4” wide replaceable blade scraper.

NOTE: DO NOT HACK, CHOP, HIT OR CUT ON THE MIRACLEAN® SURFACE. You will dent the steel plate under the trivalent chrome. It is even possible to hack two nicks close together and actually tear the MIRACLEAN® surface as the chromium will not stretch. Below is a sketch showing the side view of a griddle plate and how the surface can be damaged. Proper use of the utensils supplied with your MIRACLEAN Griddle will prevent surface damage.

Figure 3-3

Surface Damage

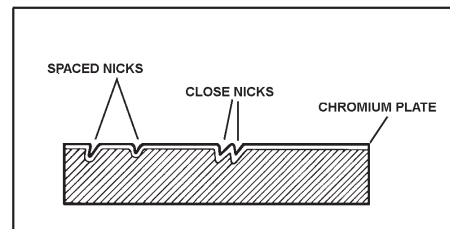

NOTE: Damage done to the MIRACLEAN® surface is irreparable and is not covered under Keating Warranty.

CLEANING THE GRIDDLE

The surface of the MIRACLEAN® Griddle is very durable and with proper care, following the procedures below, will last many years.

A sample of Keating Klenzer, Keating palmetto brush and a 4" scraper are included with each new griddle.

1. Scrape MIRACLEAN® surface with the Keating Scraper.



2. Clean with potable tap water and a Keating palmetto brush.



3. Polish surface with Keating Klenzer. Rinse with potable water to remove excess Keating Klenzer.

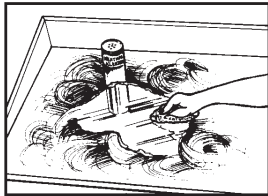

NOTE: BECAUSE OF THE SUPERIOR MIRACLEAN® SURFACE, THE ONLY TOOLS YOU WILL EVER NEED TO CLEAN THE GRIDDLE ARE A NATURAL BRISTLE BRUSH AND A KEATING SCRAPER.

■ NEVER USE A GRIDDLE STONE, BRICK OR SCREEN TO CLEAN THE MIRACLEAN® SURFACE.

■ DAMAGE DONE TO THE MIRACLEAN® SURFACE BY GRIDDLE STONE, BRICK OR SCREEN WILL VOID THE WARRANTY.

■ THE DAMAGE DONE TO THE MIRACLEAN® SURFACE IS IRREPARABLE.

■ NEVER USE ICE TO COOL THE MIRACLEAN® SURFACE. USE OF ICE MAY WARP THE MIRACLEAN® SURFACE.

■ USE ONLY KEATING SUPPLIED CLEANING TOOLS AND KLENZER.

■ USE ONLY KEATING SPATULAS.

SHUTDOWN

1. Turn each thermostat fully counterclockwise and On/Off switch to "OFF" position.

IV MAINTENANCE

WARRANTY REPAIRS

Keating's warranty begins with the date of installation. In the event that your MIRACLEAN® Electric Griddle, under warranty, needs repairs other than routine maintenance or cleaning, you are required to contact Keating of Chicago (at 1-800-KEATING) before calling a local service company.

PREVENTIVE MAINTENANCE

Preventive maintenance should be done in daily, weekly, monthly and yearly intervals as necessary. Following preventive maintenance procedures will help keep your MIRACLEAN® working efficiently. Proper care and servicing will lead to years of quality performance.

PREVENTIVE MAINTENANCE CHART

TIME FRAME	OPERATOR/ OWNER	SECTION
Daily*	<ul style="list-style-type: none"> • Check lights and controls • Clean griddle surface. • Drain and clean grease drawer. • Completely wipe down griddle cabinet. 	III
Monthly*	<ul style="list-style-type: none"> • Check condition of MIRACLEAN® surface and review proper procedures. • Check calibration of thermostat(s). • Review installation and operating instructions received with griddle. 	III IV II
Yearly*	<ul style="list-style-type: none"> • Have griddle completely checked, calibrated, tested, cleaned, etc. by qualified service personnel. 	

* High production facilities should be checked more often.

A. Griddle Surface

With proper care, the MIRACLEAN® surface and its unique cooking properties will last for many years. However, nicks or dents in the griddle surface may cause the griddle surface to lift from the depressed area. If nicks are close together, the surface may raise and be torn when a spatula or scraper is used. Care should be taken, as the damage done is irreparable. See Figure 3-3 on page 4.

CAUTION

Damage done to the MIRACLEAN® surface is irreparable and is not covered under Keating Warranty.

B. Limited Calibration (Less than 50°F difference)

You will need: One standard flat blade screwdriver
One accurate griddle thermometer

1. Set thermostat to 300°F.
2. Allow thermostat to cycle three times.
3. Locate inverted “V” on front of griddle plate above to locate thermostat bulb position. Place thermometer on plate over bulb half way toward rear of griddle.

Figure 4-1

Thermostat calibration

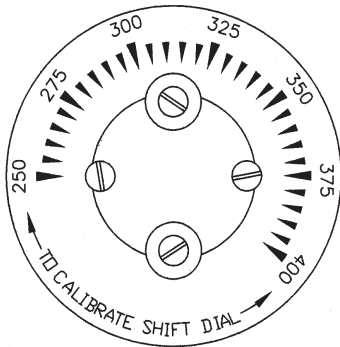

4. If calibration of griddle is found to be less than 50°F off, simply loosen four dial plate retaining screws (See Figure 4-1), rotate dial plate to match thermometer reading and tighten screws.

NOTE: Calibration is not covered under warranty.

GRIDDLE SURFACE

With proper care, the MIRACLEAN® surface and its unique properties will last for many years. However, nicks or dents in the griddle surface may cause the griddle surface to lift from the depressed area. If nicks are close together care should be taken as the damage done is irreparable. See figure 3-3 on page 4.

CLEANING

Proper care should be taken to fully clean the griddle on a regular basis.



DISCONNECT ELECTRIC POWER SOURCE BEFORE CLEANING.

A. CONTROL PANEL - Clean any grease build-up on the switches and thermostat knobs.

NOTE: If grease gets into the body of the switch or thermostat, it may cause it to fail.



IF GREASE GETS INTO THE BODY OF THE SWITCH OR THERMOSTAT, IT MAY CAUSE ELECTRICAL SHOCK.

B. CABINET - The front, back and sides of the cabinet should be kept clean for sanitary and safety reasons.

See page 5 “Cleaning the Griddle”

V SERVICE DIAGNOSIS

A. Trouble shooting

The following diagnosis is only to be used as a guide to qualified personnel. Keating recommends that you use a qualified service company. Call 1-800-KEATING if you need assistance in locating a qualified service company.

PROBLEM	PROBABLE CAUSE	SOLUTION
Griddle won't heat.	<ul style="list-style-type: none"> a No electricity to griddle. b Griddle circuit breakers (external) have tripped. c On/Off switch is on "OFF" position. d Thermostat isn't on. e On/Off switch is faulty. f Thermostat is faulty. g Connections are loose. h Element is faulty. 	<ul style="list-style-type: none"> a. Connect griddle to an approved source of power. b. Reset circuit breakers (External). c. Set On/Off switch to 'ON" position. d. Turn thermostat to desired cooking temperature. e. Replace On/Off switch. f. Replace thermostat. g. Tighten connections. h. Replace element
Indicating light does not illuminate although element is heating.	<ul style="list-style-type: none"> a. Indicating light is faulty. 	<ul style="list-style-type: none"> a. Replace indicating light
Temperature of griddle is erratic.	<ul style="list-style-type: none"> a. Thermostat out of calibration. b. Thermostat bulb improperly placed. c. Exhaust problems or drafts in kitchen. 	<ul style="list-style-type: none"> a. Calibrate thermostat. See page 6 – Calibration. b. Adjust thermostat bulb. c. Contact your HVAC representative.
Griddle is overheating.	<ul style="list-style-type: none"> a. Thermostat out of calibration. b. Thermostat is faulty. c. Improper exhaust or draft. 	<ul style="list-style-type: none"> a. Calibrate thermostat. See page 6 – Calibration. b. Replace thermostat. c. Contact your HVAC representative.

VI PARTS LIST

ORDERING PARTS

Parts may be ordered by calling 1-800-KEATING or your local Keating service company. You may also order on-line at Keating's part store, www.keatingofchicago.com

Refer to the Keating MIRACLEAN® Electric Griddle Limited Warranty for complete service and ordering information.

The model/serial plate is located inside of the grease drawer area to the left or on the front of the upper heat shield above the control panel. The serial and model numbers are necessary when ordering.

WARNING AND OPERATING PLATES

All warning and operating plates on the Keating MIRACLEAN® Electric Griddle should be in place at all times. If plates are damaged or lost, replace them immediately.

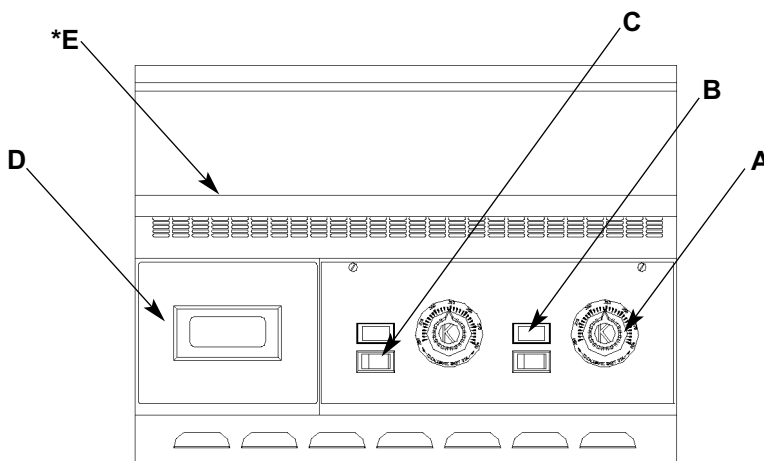

	Part No.	Description
A	035954	Thermostat 400°
	029521	Thermostat 550°
	034870	Thermostat Dial Plate 400°
	058038	Thermostat Dial Plate 550°
	004163	Thermostat Knob 400°
	009914	Thermostat Knob 550°
B	050255	Light
C	054920	Switch
D	052505	Grease Drawer
	002457	Grease Drawer for Model 32 A only
*E	<i>Not shown on this page. See page 9.</i>	

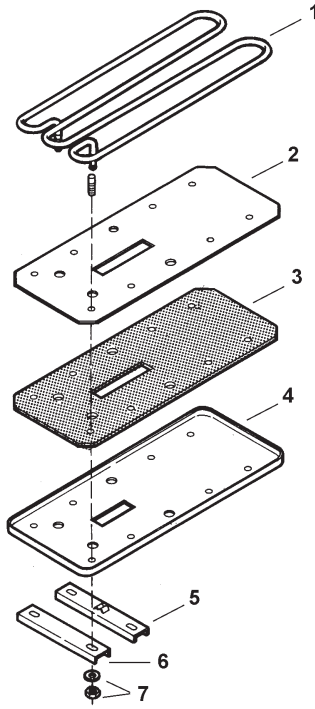

Figure 6-3
Heating Element Assembly

To replace thermostat:

- Loosen nuts (#7)
- Loosen nuts to Dispersion Plate (if needed)
- Slide thermostat bulb through slots pictured in items 2, 3, & 4.
- With bulb tight against the plate, tighten all nuts.

ITEM	DESCRIPTION	PART NUMBER	QTY 24" DEEP	QTY 30" DEEP	QTY 33" DEEP
1	HEATING ELEMENT				
	2300W, 220V	002478	1		
	3000W, 220V	002483		1	
	3750W, 220V	002487			1
	3300W, 220V (HIGH INPUT, TEPPANYAKI)	002482	1		
	4370W, 220V (HIGH INPUT)	002480		1	
2	HEATING ELEMENT PAN	020553	1		
		020554		1	
		020556			1
3	INSULATION BOARD	002489	1		
		002493		1	
		002490			1
4	HEAT DISPERSION PLATE	005913	1		
		006228		1	
		006229			1
5	HEATING ELEMENT BULB				
	HOLD DOWN "M" BRACKET	008593	1	1	1
6	HEATING ELEMENT HOLD DOWN BRACKET				
		029352	3	4	5
7	3/8" NUT, WASHER, LOCK-WASHER AND PALNUT				
		028736	8	10	12

NOTE: Quantities shown are for each element. See Specifications on pages 11 to 13 for the number of elements for your griddle.

Assembly instructions for griddle stand on casters

(There is no top on this stand)

LEFT SIDE VIEW

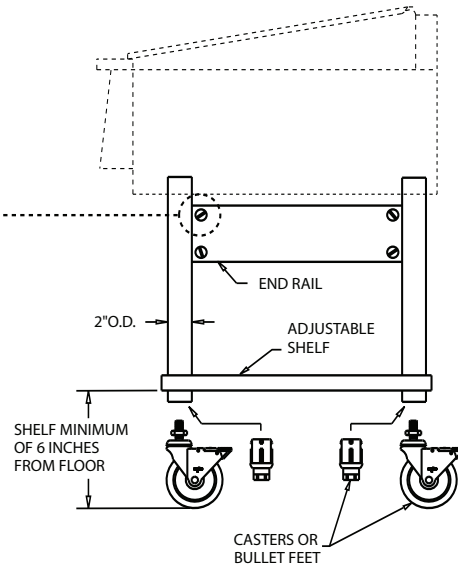
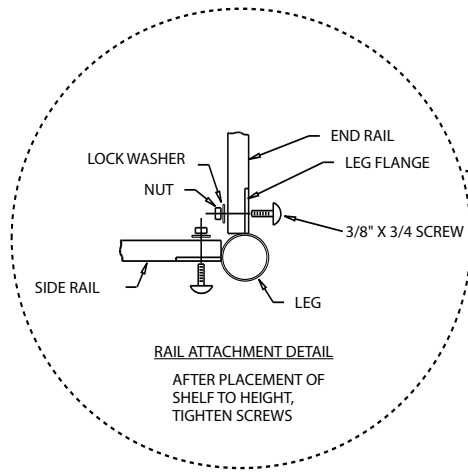

LEGS WITH BULLET FEET 22" LONG
LEGS WITH CASTERS 16" LONG
STAND TOTAL HEIGHT 23"
(WITH BULLET FEET OR CASTERS)

FRONT VIEW

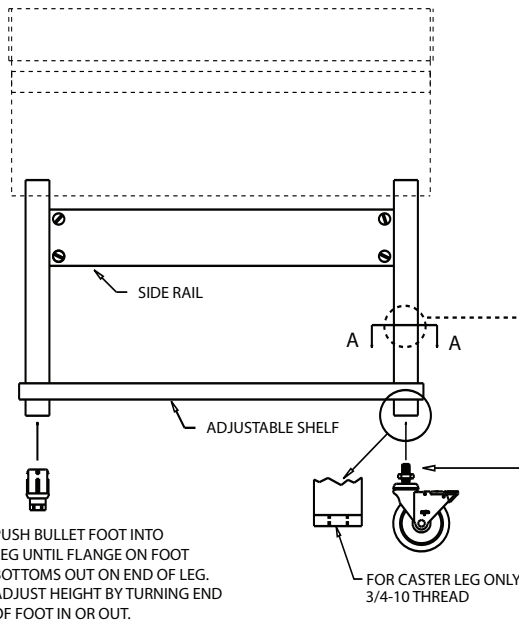

VIEW A - A OF SHELF

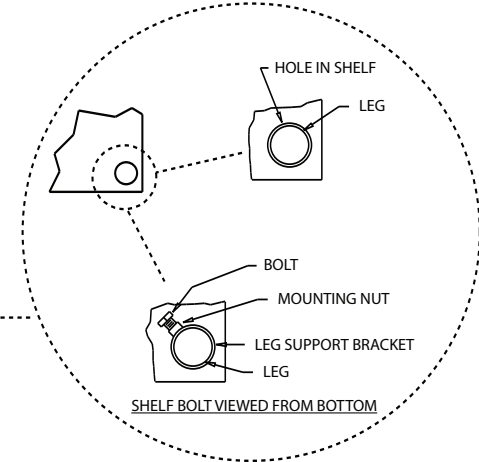

SCREW CASTERS INTO LEG ALL THE WAY AND TIGHTEN LOCK NUT. TO ADJUST HEIGHT, LOOSEN LOCK NUT AND SCREW CASTER OUT. RE-TIGHTEN LOCK NUT.

VII WIRING DIAGRAM

NOTE: Griddles rated at 480 volts use type D-1 thermostats which include On/Off switches. Separate On/Off switches are not provided with these griddles. The following wiring diagram is for griddles rated at 208-240 volts which have separate On/Off switches.

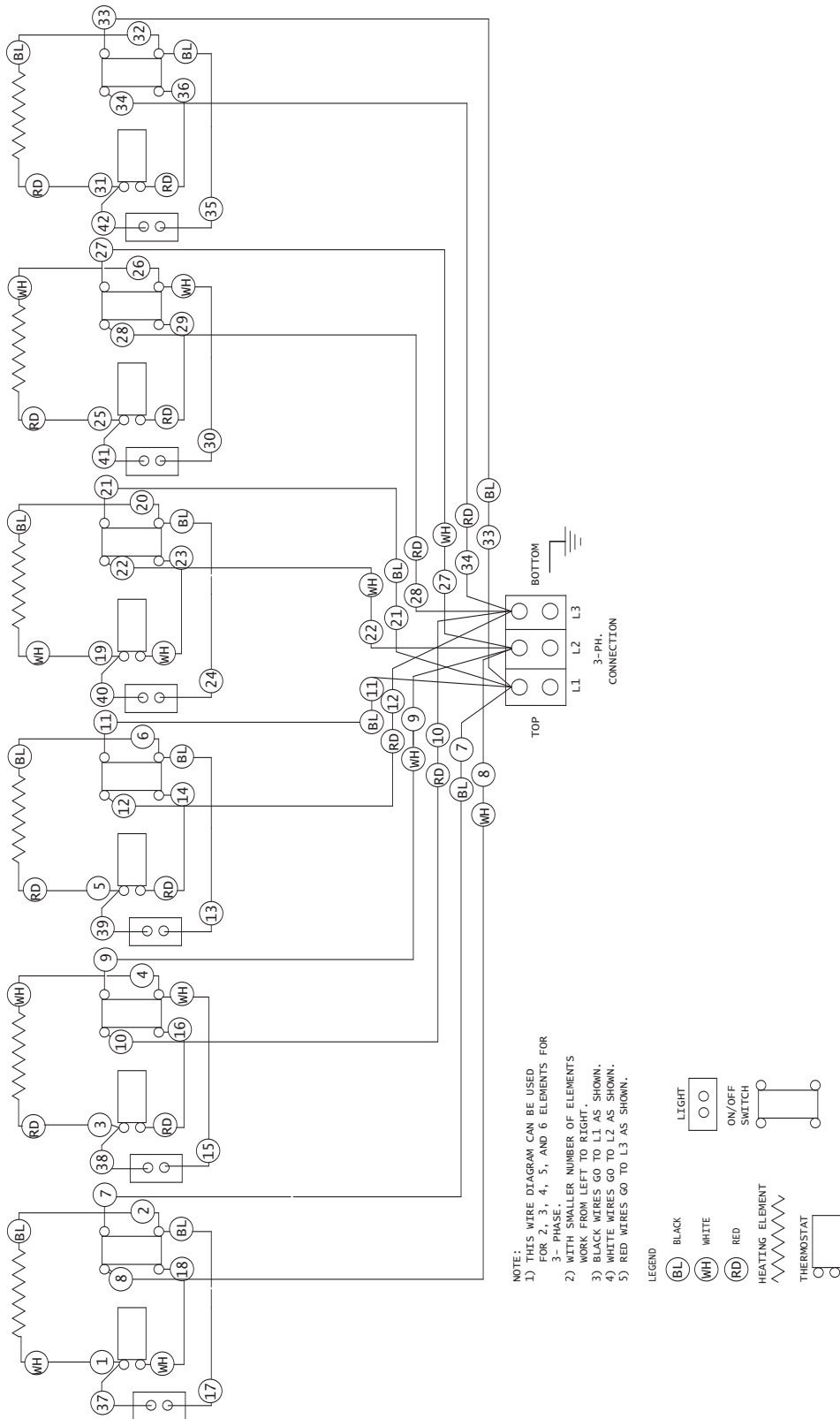

VIII KEATING GRIDDLE SPECIFICATIONS

MODELS: STANDARD & FRONT TROUGH ONLY

24" DEEP MODELS

27x24 30x24

VOLTS	kW	AMPS PER LINE-THREE PHASE			AMPS SINGLE PHASE
		L1	L2	L3	
208	4.1	10	17	10	20
220	4.6	11	18	11	21
240	5.5	11	20	11	23

- 2 ELEMENTS (2300 W EACH)

36x24

VOLTS	kW	AMPS PER LINE-THREE PHASE			AMPS SINGLE PHASE
		L1	L2	L3	
208	6.2	17	17	17	30
220	6.9	18	18	18	31
240	8.2	20	20	20	34

- 3 ELEMENTS (2300 W EACH)

42x24 / 48x24

VOLTS	kW	AMPS PER LINE-THREE PHASE			AMPS SINGLE PHASE
		L1	L2	L3	
208	8.2	26	26	17	40
220	9.2	28	28	18	42
240	10.9	30	30	20	46

- 4 ELEMENTS (2300 W EACH)

60x24

VOLTS	kW	AMPS PER LINE-THREE PHASE			AMPS SINGLE PHASE
		L1	L2	L3	
208	10.3	26	34	26	49
220	11.5	28	36	28	52
240	13.7	30	40	30	57

- 5 ELEMENTS (2300 W EACH)

MODELS: STANDARD & FRONT TROUGH ONLY

30" DEEP MODELS

24x30 27x30 30x30

VOLTS	kW	AMPS PER LINE-THREE PHASE			AMPS SINGLE PHASE
		L1	L2	L3	
208	5.4	13	22	13	26
220	6.0	14	24	14	27
240	7.1	15	26	15	30

- 2 ELEMENTS (3000 W EACH)

36x30

VOLTS	kW	AMPS PER LINE-THREE PHASE			AMPS SINGLE PHASE
		L1	L2	L3	
208	8.0	22	22	22	39
220	9.0	24	24	24	41
240	10.7	26	26	26	45

- 3 ELEMENTS (3000 W EACH)

42x30 / 48x30

VOLTS	kW	AMPS PER LINE-THREE PHASE			AMPS SINGLE PHASE
		L1	L2	L3	
208	10.7	34	34	22	52
220	12.0	36	36	24	55
240	14.3	39	39	26	60

- 4 ELEMENTS (3000 W EACH)

60x30

VOLTS	kW	AMPS PER LINE-THREE PHASE			AMPS SINGLE PHASE
		L1	L2	L3	
208	13.4	34	45	34	65
220	15.0	36	47	36	68
240	17.9	39	52	39	74

- 5 ELEMENTS (3000 W EACH)

72x30

VOLTS	kW	AMPS PER LINE-THREE PHASE			AMPS SINGLE PHASE
		L1	L2	L3	
208	16.1	41	41	41	77
220	18.0	45	45	45	82
240	21.4	52	52	52	89

- 6 ELEMENTS (3000 W EACH)

MODELS: STANDARD & FRONT TROUGH ONLY

36" DEEP MODELS

36x36

VOLTS	kW	AMPS PER LINE-THREE PHASE			AMPS SINGLE PHASE
		L1	L2	L3	
208	10.1	28	28	28	48
220	11.3	30	30	30	51
240	13.4	32	32	32	56

- 3 ELEMENTS (3750 W EACH)

42x36 48x36

VOLTS	kW	AMPS PER LINE-THREE PHASE			AMPS SINGLE PHASE
		L1	L2	L3	
208	13.4	43	43	28	65
220	15.0	45	45	30	68
240	17.9	49	49	32	75

- 4 ELEMENTS (3750 W EACH)

60x36

VOLTS	kW	AMPS PER LINE-THREE PHASE			AMPS SINGLE PHASE
		L1	L2	L3	
208		43	56	43	81
220		45	59	45	85
240	22.3	49	64	49	93

- 5 ELEMENTS (3000 W EACH)

72x36

VOLTS	kW	AMPS PER LINE-THREE PHASE			AMPS SINGLE PHASE
		L1	L2	L3	
208	20.1	56	56	56	97
220	22.5	59	59	59	102
240	26.8	64	64	64	112

- 6 ELEMENTS (3750 W EACH)



WARRANTY

LIMITED WARRANTY

Keating Of Chicago, Inc. ("Keating") warrants to the original purchaser. ("Customer"), all new Keating Fryers, Filter Systems, Griddles, Keep Krisp[®], Custom Pasta Systems, Top-Side[™] Cookers, Computer Timers, Fryer & Pasta Vessels, and Keating replacement parts ("products") installed after June 1, 1994 to be free to defects in material or workmanship, subject to the following terms and conditions.

LENGTH OF WARRANTY

All products other than Fryer & Pasta Vessels and replacement parts shall be warranted for a period of one year from the date of original equipment installation. Keating replacement parts are warranted for a period of ninety days from the date of installation. Fryer & Pasta Vessels are warranted as described below.

FRYER & PASTA VESSEL WARRANTY

Fryers purchased after June 1, 1994 carry a prorated vessel warranty on defects in materials or workmanship to the Customer based on the following scale:

Time from Installation Date	Fryer Vessel Warranty Credit
13-60 months	100%
61-72 months	80%
73-84 months	60%
85-96 months	40%
97-108 months	20%
109-120 months	10%

The credit for the defective fryer & pasta vessel shall be applied against the cost of the replacement vessel, utilizing Keating's then current price, upon return of the vessel to Keating. (Freight to be paid by Keating within the first 2 months only), only during the first 60 months as described above, subject to the limitations described below.

LIMITATIONS OF LIABILITY

In the event of warranty claim or otherwise, the sole obligation of Keating shall be the repair and/or replacement at the option of Keating of the product or component or part thereof. Such repair or replacement shall be at the expense of Keating except that the Customer shall pay the following expenses: all freight and labor expense for Keating replacement parts for all other products, mileage exceeding 50 miles or travel more than one hour, labor costs of more than one person, overtime rates, truck charges, difference between ground and other mode of transportation, and holiday charges. Any repair or replacement under this Limited Warranty does not constitute an extension of the original warranty for any period for the product or for any component or part thereof. Parts to be replaced under this Limited Warranty will be repaired at the option of Keating with new or functionally operative parts. Keep Krisps and Computer Timers must be returned to Keating for warranty repair or replacement. Field repairs of those items are not authorized.

THE LIABILITY OF KEATING ON ANY CLAIM OF ANY KIND, INCLUDING CLAIMS BASED ON WARRANTY, EXPRESSED OR IMPLIED, CONTRACT, NEGLIGENCE, STRICT LIABILITY OR ANY OTHER THEORIES SHALL BE SOLELY AND EXCLUSIVELY THE REPAIR OR REPLACEMENT OF THE PRODUCT AS STATED HEREIN, AND SUCH LIABILITY SHALL NOT INCLUDE, AND CUSTOMER SPECIFICALLY RENOUNCES ANY RIGHTS TO RECOVER, SPECIAL, INCIDENTAL, CONSEQUENTIAL OR OTHER INJURIES TO PERSONS OR DAMAGE TO PROPERTY, LOSS OF PROFITS OR ANTICIPATED PROFITS, OR LOSS OF USE OF THE PRODUCT.

If any oral statements have been made regarding the Keating products, such statements do not constitute warranties and are not part of the contract sale. This Limited Warranty constitutes the complete, final and exclusive statement with regard to warranties.

THIS LIMITED WARRANTY IS EXCLUSIVE AND IS IN LIEU OF ALL OTHER WARRANTIES WHETHER WRITTEN, ORAL, STATUTORY OR IMPLIED, INCLUDING BUT NOT LIMITED TO ANY WARRANTY OF MERCHANTABILITY OR FITNESS FOR PARTICULAR PURPOSE OR WARRANTY AGAINST LATENT DEFECTS.

The warranties provided by Keating of Chicago, Inc. do not apply in the following instances:

1. Defects arising out of or resulting from improper installation or maintenance, abuse, misuse, modification or alteration by unauthorized service personnel, or any other condition not attributable to a defect in material or workmanship. Proper installation and maintenance are the responsibility of the installer and Customer, respectively. Proper installation and maintenance procedures are prescribed by the Keating Service Manual.
2. In the event that the product was damaged after leaving the factory due to flood, fire, other acts of God or accident, damage during shipment should be reported to the carrier and is not the responsibility of Keating.
3. In the event the serial number or rating plate has been removed from the product or altered.
4. On parts which would normally be worn or replaced under normal conditions, including but not limited to electric bulbs, fuses, interior and exterior finishes, gaskets and radiants.
5. With regard to adjustments and calibrations such as leveling, tightening of fasteners or plumbing connections, improper gas pressure or improper electrical supply, the checking of and changes in adjustment and calibrations are the responsibility of the installer. Proper installation procedures are prescribed by the Keating Service Manual.
6. In the event of unauthorized repairs or alterations to the Keating product.
7. With the use of sodium chloride in pasta vessels or harsh chemicals in fryer or pasta vessels.

The Customer must provide proof of purchase from Keating.

OTHER TERMS AND CONDITIONS

This Limited Warranty is valid in the 50 United States, its territories, and Canada, and is void elsewhere.

Keating products are sold for commercial use only. If any Keating product is sold as a component of another product or used as a consumer product, such Keating product is sold As Is without any warranty. If any provision of this Limited Warranty is held to be unenforceable under the law of any jurisdiction, such provision shall be inapplicable in such jurisdiction, and the remainder of the warranty shall remain unaffected. Further in such event, the maximum exclusion or limitation allowable under applicable law shall be deemed substituted for the unenforceable provision. This Limited Warranty shall be governed by and construed in accordance with the laws of the State of Illinois.

TO SECURE WARRANTY SERVICE

All repair services under this Limited Warranty must be authorized by Keating or performed at Keating. Authorization may be obtained by calling 1-800-KEATING within the Continental United States, Alaska, Hawaii, Puerto Rico and Canada during normal business hours (7:00 a.m. through 6:00 p.m. Central Time, Monday through Friday). When calling, please have the following information available: (1) name, address and telephone number of the Customer; (2) location of product, if different; (3) name, model number and serial number of the product; (4) installation date; and (5) description of defect. Keating will then issue a service authorization work order number to one of its approved independent servicing organizations, or request the product or part be shipped to Keating for repair or replacement, as appropriate. Any defective part subject to a claim under this Limited Warranty must be shipped freight prepaid to Keating for testing and examination. Keating's decision as to the cause and nature of any defect under this Limited Warranty shall be final.

KEATING

KEATING OF CHICAGO, INC., 1-800-KEATING WWW.KEATINGOFCHICAGO.COM

SERVICE INFORMATION

If you have a service related question call 1-800-KEATING.
Please state the nature of the call; it will ensure speaking with the appropriate person.
Have your serial and model number available when ordering parts.

KEATING OF CHICAGO, INC.

8901 W. 50th Street, McCook, Illinois 60525-6001
Phone: (708) 246-3000 FAX: (708) 246-3100
Toll Free 1-800-KEATING (In U.S. and Canada)
www.keatingofchicago.com

***As continuous product improvement occurs, specifications may be changed without notice.**

KEATING LIMITED WARRANTY CARD

PLEASE COMPLETE AND MAIL AT ONCE--WARRANTY IS NOT IN EFFECT UNTIL CARD IS RETURNED

COMPANY: _____

ADDRESS: _____

CITY: _____ STATE: _____ ZIP: _____

DEALER: _____

DATE OF PURCHASE: _____ INVOICE NUMBER: _____

SERIAL NUMBER: _____ FRYER FILTER SYSTEM GRIDDLE

REMARKS: _____ TOP-SIDE COOKER HOT PLATE PASTA PLUS

I HAVE READ THE INSTALLATION AND OPERATION INSTRUCTIONS.

SIGNED: _____ DATE: _____

"Sewing Those Who Serve The Very Best"®