

# Challenger



## Rotary Glasswashing System

- Completely automatic pre-set wash and rinse programs
- Performance is quality-controlled by electronic solid state circuitry
- Individual and adjustable variable speed peristaltic pumps for: detergent, sanitizer and rinse-additive
- Electric tank heater for consistent wash temperature
- Low water tank heat protection cut-off system
- Glassware activated on and off stopping device
- Detergent sensor probe designed to ensure the correct detergent levels - thereby eliminating wastage
- Production rating of approx. 1000 glasses per hour

# Challenger

## CONSTRUCTION FEATURES

- Jet Tech® rotary-conveyor wash system
- Body features long-life unitized design
- Top cover easily removed for access to inner wash area compartment and tank
- Total accessibility reduces maintenance time
- Open clearance height of 10" which provides for washing of tall glassware
- Built-in inner waste compartment to trap unwanted scrap materials and particles
- Split door design allowing easy access to both electrical controls as well as chemical containers
- Convenient cabinet on right side for chemical storage
- Exclusive design of stainless steel wash and rinse blocks
- Conveyor system with a side-driven gear mechanism provides for smooth and quiet rotation of the conveyor assembly

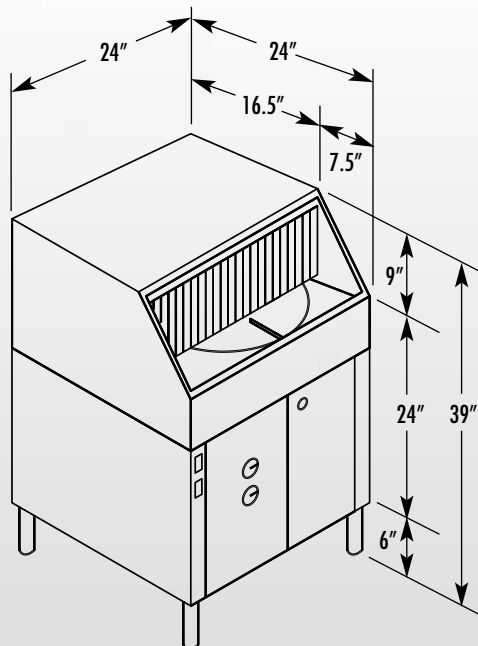

## TECHNICAL FEATURES

- **Conveyor capacity:** 350 sq. in.
- **Conveyor movement:** 1/3 r.p.m. (clockwise)
- **Water consumption:** 3.0 gal/min (max.)
- **Wash temperature:** 140°F. (60°C)
- **Rinse temperature:** 75°F. (24°C)
- **Tank heat:** 4000 Watts
- **Electrical data:** 110/220/60/1 — 20 amps
- **Water connection:** Hot and Cold water inlets (see below)
- **Drain connection:** Gravity-flow type (see below)
- **Operating pressure:** 25 to 35 p.s.i.
- **Shipping weight:** 200 lbs.

## CONSULTANT SPECIFICATION:

The glass washer must be a Jet-Tech **Challenger** rotary glasswashing system complete with: an easy removable top cover, built-in scrap/waste compartment, hot and cold water inlets, automatic pre-set wash and rinse programs, an electric tank heater, a low water tank heat protection cut-off, a detergent sensor probe, separate adjustable peristaltic pumps for detergent, sanitizer and rinse additive, a gear driven conveyor system, electrical rating of 110/220V, and approx. capacity of 1000 glasses per hour.

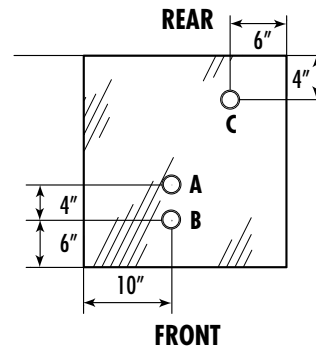

A: Cold Water: 1/2" NPTF  
B: Hot Water: 1/2" connection  
C: Drain: 1 1/2" gravity-flow type

## JET TECH SYSTEMS CORP.

TEL: (514) 737-9701  
TOLL FREE TEL: (888) 275-4538  
jet-tech.com

FAX: (514) 342-3854  
TOLL FREE FAX: (877) 453-8832  
sales@jet-tech.com



ANSI/NSF-3

In line with our continuing policy on research and product development, we reserve the right to alter specifications without notice.

