

**LEGEND**

- TB: terminal block, (control wiring)
- NFC: audio filter ( electrical noise distortion)
- PS: pressure switch, control water level
- SV: solenoid valve
- DS: door switch
- SW1: cycle switch ( start switch )
- TM: timer motor
- TS1: timer microswitch ( TM )
- TS2: timer microswitch ( TM )
- TS3: timer microswitch ( TM )
- WP: wash pump
- R-THS: rinse thermostat
- W-THS: wash thermostat
- HCC: booster heater contactor
- LP1: power on-off indicator light
- LP2: ready indicator light
- LP3: cycle indicator light
- O/L: over load protection(wash pump)
- WHT: wash heater (contactor)
- C: capacitor
- TG: temperature gauge

**TIMER PROGRAM**

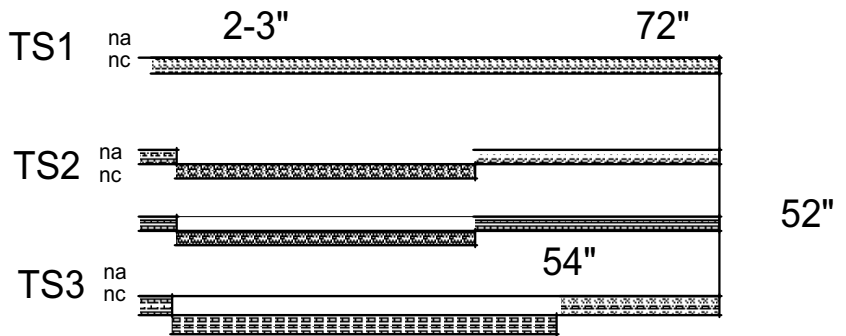

H4P 1N3 Canada