

# TECHNICAL MANUAL

INSTALLATION MANUAL FOR EXPORT UNITS  
SERVICE MANUAL FOR DOMESTIC UNITS

FOR JACKSON MODELS:

TEMPSTAR GPX

TEMPSTAR HH GPX



# ***Jackson***







## TEMPSTAR HH GPX

TEMPSTAR GPX = Gas heated, hot water sanitizing, door-type dishmachine

TEMPSTAR HH GPX = Gas heated, hot water sanitizing, door-type dishmachine with higher hood

Model: \_\_\_\_\_

Serial No.: \_\_\_\_\_

Installation Date: \_\_\_\_\_

Service Rep. Name: \_\_\_\_\_

Phone No.: \_\_\_\_\_

---

## TABLE OF CONTENTS

---

<u>Section</u>	<u>Description</u>	<u>Page</u>
<b>I.</b>	<b>SPECIFICATION INFORMATION</b>	
	Specifications of the Tempstar GPX	2
	Specifications of the Tempstar HH GPX	3
	Dimensions for the Tempstar GPX	4
	Dimensions for the Tempstar HH GPX	5
	Table Dimensions	6
<b>II.</b>	<b>INSTALLATION/OPERATION INSTRUCTIONS</b>	
	Installation Instructions	8
	Electrical Installation Instructions	9
	Gas Booster Heater Connection	10
	Operation Instructions	12
<b>III.</b>	<b>PREVENTATIVE MAINTENANCE</b>	15
<b>IV.</b>	<b>TROUBLESHOOTING</b>	17
<b>V.</b>	<b>SERVICE PROCEDURES</b>	
	Rinse Solenoid Valve Repair Parts Kit	20
	Vacuum Breaker Repair Parts Kit	22
<b>VI.</b>	<b>PARTS</b>	
	Control Box Assembly, Tempstar GPX	27
	Control Box Assembly, Tempstar HH GPX	29
	Hood Assembly, Tempstar GPX	31
	Hood Assembly, Tempstar HH GPX	32
	Frame Assemblies	33
	Tub Assembly	34
	Cantilever Arm/Door Assembly, Tempstar GPX	36
	Cantilever Arm/Door Assembly, Tempstar HH GPX	38
	Inlet Plumbing Assemblies	40
	Rinse Header Plumbing Assembly	41
	Recirculating Plumbing Assembly	42
	1/2" Solenoid Valve/Vacuum Breaker Repair Kits	43
	Wash & Rinse Assemblies, Tempstar GPX	44
	Wash & Rinse Assemblies, Tempstar HH GPX	46
	Steam Coil Assembly	48
	Exhaust Fan Control Option/Safety Door Interlock Option	49
	Tempstar GPX False Panel Installation	50
	Tempstar HH GPX False Panel Installation	51
	Drain Quench Option	52
<b>VII.</b>	<b>SCHEMATICS</b>	
	115 Volt, 50/60 Hertz, Single Phase Tempstar GPX	54
	208 - 230 Volt, 50/60 Hertz, Single & Three Phase Tempstar GPX	55
	115 Volt, 50/60 Hertz, Single Phase Tempstar HH GPX	56
	208 -230 Volt, 50/60 Hertz, Single & Three Phase Tempstar HH GPX	57
	Exhaust Fan Control Option/Safety Door Interlock Option	58

---

# **SECTION 1: SPECIFICATION INFORMATION**

## SECTION 1: SPECIFICATION INFORMATION

### SPECIFICATIONS OF THE TEMPSTAR GPX

#### PERFORMANCE/CAPABILITIES

##### OPERATING CAPACITY (RACKS/HOUR)

RACKS PER HOUR	57
DISHES PER HOUR	1425
GLASSES PER HOUR	1425

##### OPERATING CYCLE (SECONDS)

WASH TIME	45
RINSE TIME	11
DWELL TIME	2
TOTAL CYCLE TIME	60

##### TANK CAPACITY (GALLONS)

WASH TANK (MINIMUM)	8.0
---------------------	-----

##### WASH PUMP CAPACITY

GALLONS PER MINUTE	150
--------------------	-----

#### ELECTRICAL REQUIREMENTS

WASH PUMP MOTOR HP	3/4
RECIRCULATOR PUMP MOTOR HP	1/8

**NOTE: Typical Electrical Circuit is based upon (1) 125% of the full amperage load of the machine and (2) typical fixed-trip circuit breaker sizes as listed in the NEC 2002 Edition. Local codes may require more stringent protection than what is displayed here. Always verify with your electrical service contractor that your circuit protection is adequate and meets all applicable national and local codes. These numbers are provided in this manual simply for reference and may change without notice at any given time.**

<u>VOLTS</u>	<u>PH</u>	<u>HZ</u>	<u>RINSE HEATER RATINGS</u>	<u>TOTAL AMPS</u>	<u>TYPICAL ELECTRICAL CIRCUIT</u>
110 - 120	1	60	N/A	14	20 AMP
208 - 240	1	60	N/A	7	15 AMP

#### WATER REQUIREMENTS

<u>INLET TEMPERATURE</u>	<u>BOOSTER OUTPUT (BTU)</u>
60 -110°F	100,000
110 -140°F	60,000
WASH TEMPERATURE (MINIMUM)	150°F
RINSE TEMPERATURE (MINIMUM)	180°F
GALLONS PER HOUR	52.2
WATER LINE SIZE I.P.S. (Minimum)	1/2"
DRAIN LINE SIZE I.P.S. (Minimum)	1-1/2"
FLOW PRESSURE P.S.I.	20± 5

**NOTE: Always refer to the machine data plate for specific electrical and water requirements. The material provided on this page is for reference only and may be subject to change without notice.**

## SECTION 1: SPECIFICATION INFORMATION

### SPECIFICATIONS OF THE TEMPSTAR HH GPX

#### PERFORMANCE/CAPABILITIES

##### OPERATING CAPACITY (RACKS/HOUR)

RACKS PER HOUR	53
DISHES PER HOUR	1325
GLASSES PER HOUR	1325

##### OPERATING CYCLE (SECONDS)

###### SELECTION (A)

WASH TIME	45
RINSE TIME	15
TOTAL CYCLE TIME	60

###### SELECTION (B)

WASH TIME	103
RINSE TIME	15
DWELL TIME	2
TOTAL CYCLE TIME	120

###### SELECTION (C)

WASH TIME	163
RINSE TIME	15
DWELL TIME	2
TOTAL CYCLE TIME	180

###### SELECTION (D)

WASH TIME	283
RINSE TIME	15
DWELL TIME	2
TOTAL CYCLE TIME	300

##### TANK CAPACITY (GALLONS)

WASH TANK (MINIMUM)	8.0
---------------------	-----

##### WASH PUMP CAPACITY

GALLONS PER MINUTE	150
--------------------	-----

#### ELECTRICAL REQUIREMENTS

WASH PUMP MOTOR HP	2.0
RECIRCULATOR PUMP MOTOR HP	1/8

**NOTE: Typical Electrical Circuit is based upon (1) 125% of the full amperage load of the machine and (2) typical fixed-trip circuit breaker sizes as listed in the NEC 2002 Edition. Local codes may require more stringent protection than what is displayed here. Always verify with your electrical service contractor that your circuit protection is adequate and meets all applicable national and local codes. These numbers are provided in this manual simply for reference and may change without notice at any given time.**

<u>VOLTS</u>	<u>PH</u>	<u>HZ</u>	<u>RINSE HEATER RATINGS</u>	<u>TOTAL AMPS</u>	<u>TYPICAL ELECTRICAL CIRCUIT</u>
110 - 120	1	60	N/A	24	20 AMP
208 - 240	1	60	N/A	7	15 AMP

#### WATER REQUIREMENTS

<u>INLET TEMPERATURE</u>	<u>BOOSTER OUTPUT (BTU)</u>
LESS THAN 60°F	200,000
60 -110°F	100,000
140°F	60,000
WASH TEMPERATURE (MINIMUM)	150°F
RINSE TEMPERATURE (MINIMUM)	180°F
GALLONS PER HOUR	72.0
WATER LINE SIZE I.P.S. (MINIMUM)	1/2"
DRAIN LINE SIZE I.P.S. (MINIMUM)	1-1/2"
FLOW PRESSURE P.S.I.	20±5

**NOTE: Always refer to the machine data plate for specific electrical and water requirements. The material provided on this page is for reference only and may be subject to change without notice.**

# SECTION 1: SPECIFICATION INFORMATION

## DIMENSIONS FOR TEMPSTAR GPX

- A** - DRAIN 1 1/2" NPT
- B** - WATER INLET 1/2" NPT
- C** - ELECTRICAL CONNECTION

### LEGEND

- D** - STANDARD WALL CLEARANCE WITH DISHTABLE 4"
- E** - OUTLET TO BOOSTER HEATER 3/4" NPT
- F** - INLET FROM BOOSTER HEATER 3/4" NPT

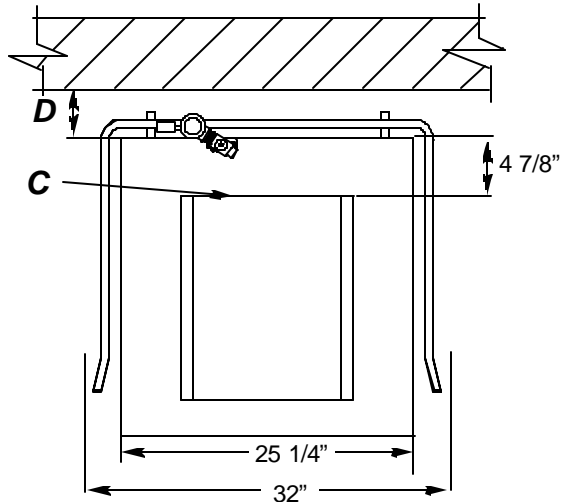
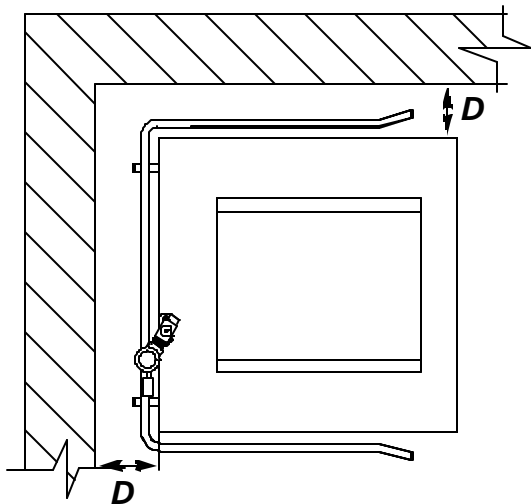

ALL DIMENSIONS ARE +/- 1/2" DUE TO ADJUSTABLE FEET.

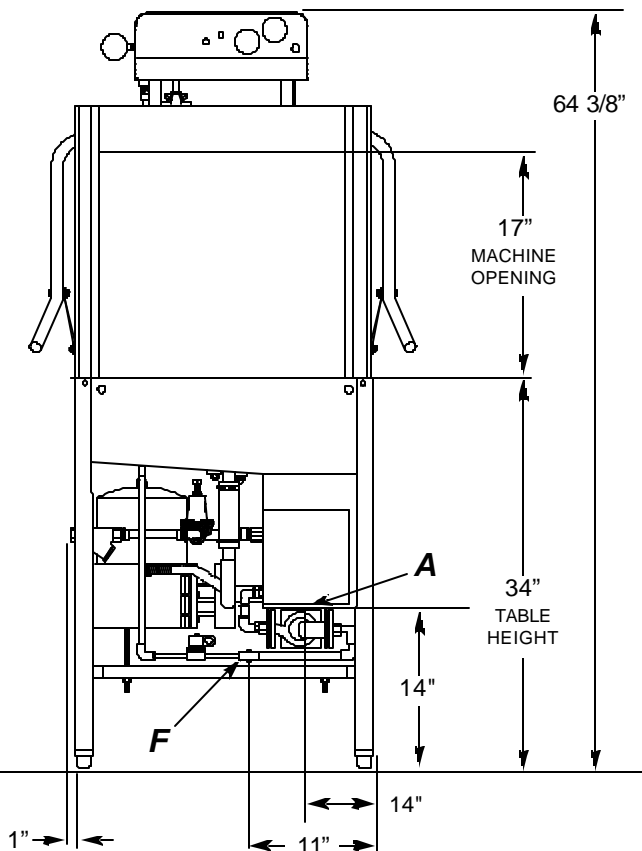
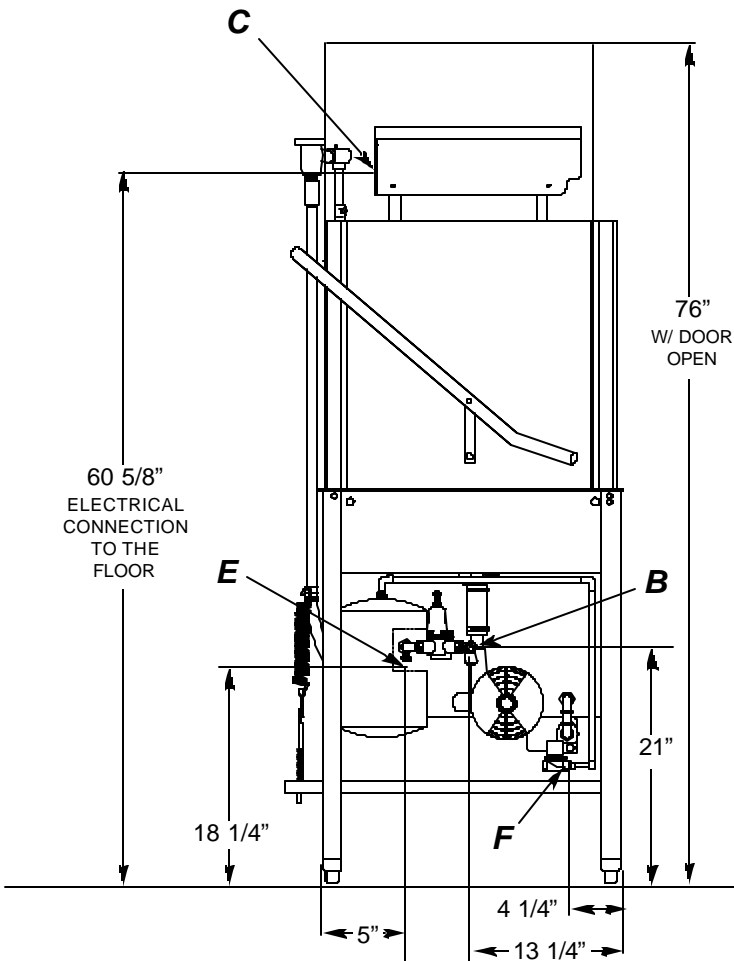

## SECTION 1: SPECIFICATION INFORMATION

### DIMENSIONS FOR TEMPSTAR HH GPX

**LEGEND:**

- A** - DRAIN 1 1/2" NPT
- B** - WATER INLET 1/2" NPT
- C** - ELECTRICAL CONNECTION
- D** - STANDARD WALL CLEARANCE WITH DISHTABLE 4"
- E** - OUTLET TO BOOSTER HEATER 3/4" N.P.T.
- F** - INLET FROM BOOSTER HEATER 3/4" N.P.T.

ALL DIMENSIONS ARE +/- 1/2" DUE TO ADJUSTABLE FEET.

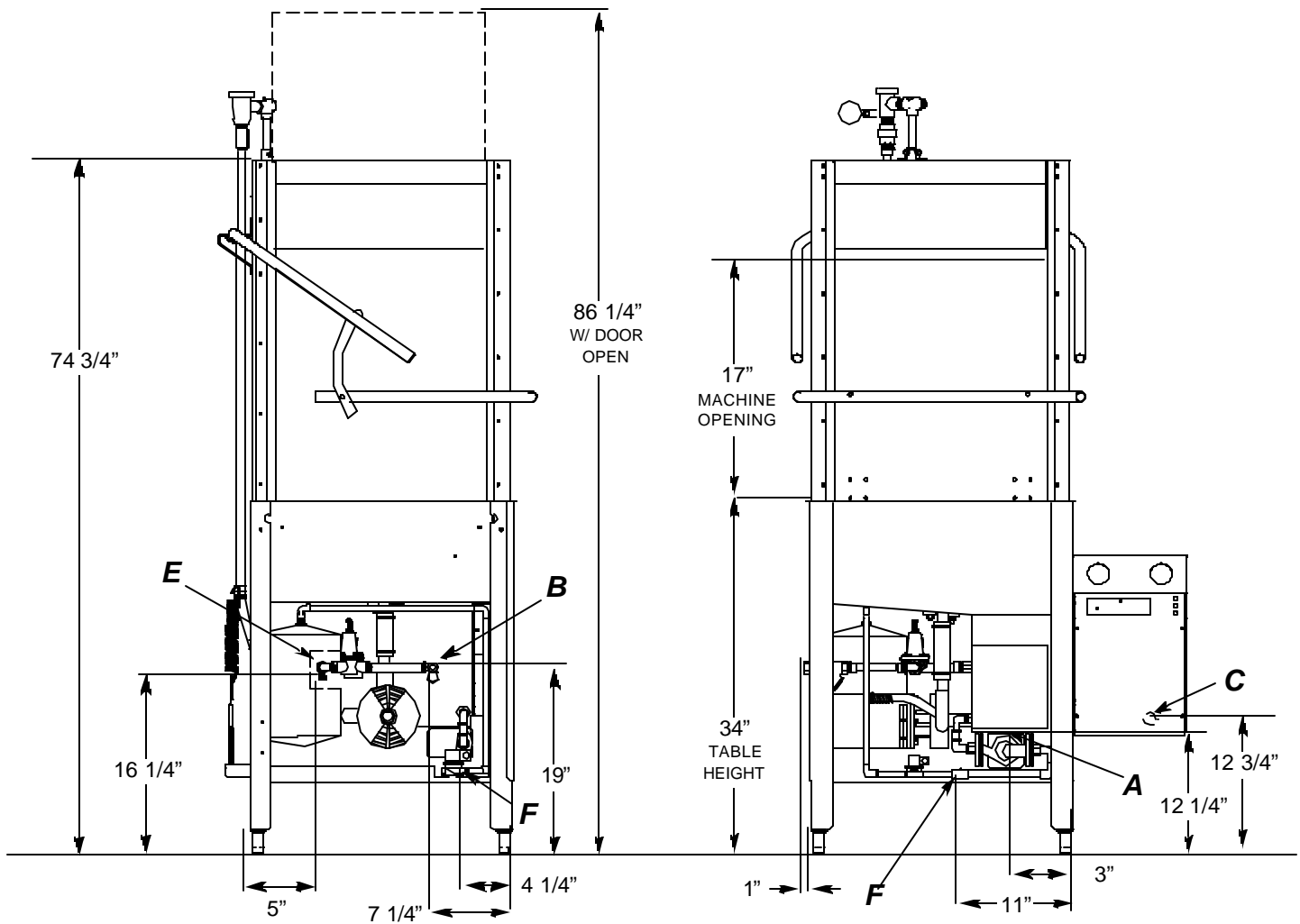
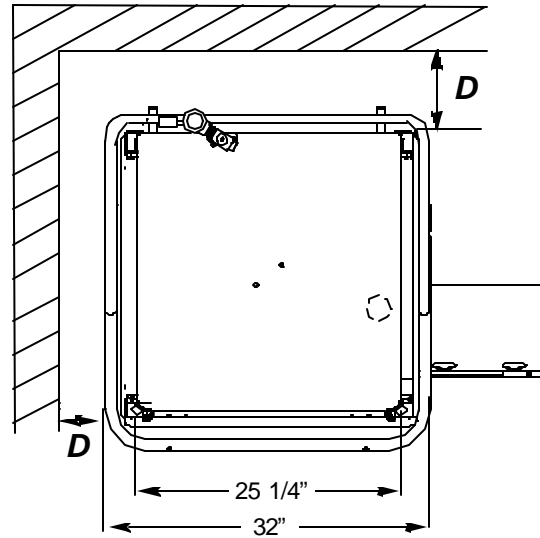

# SECTION 1: SPECIFICATION INFORMATION

## TABLE DIMENSIONS

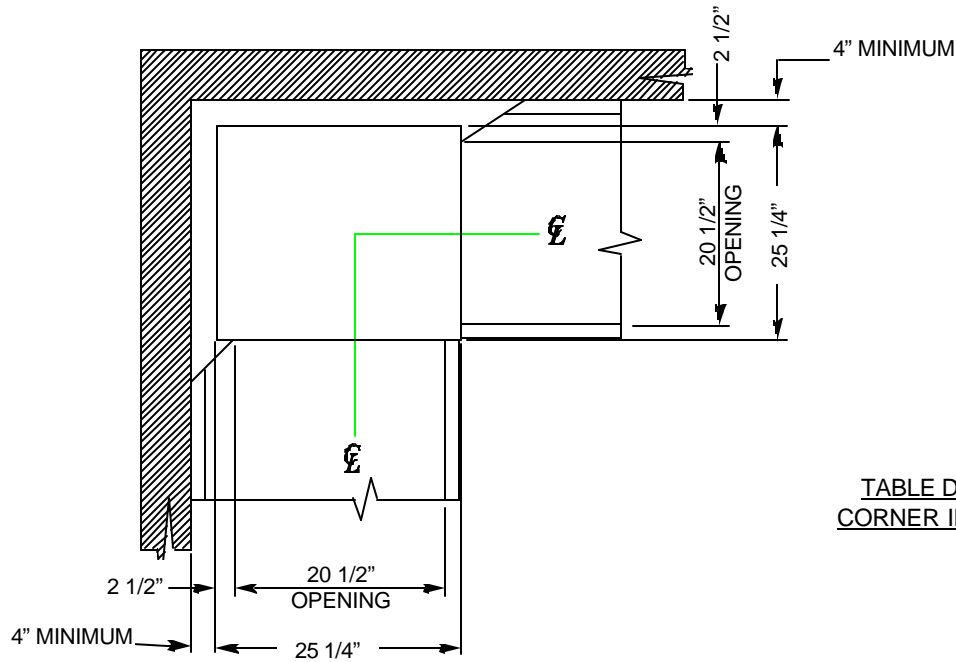

TABLE DIMENSIONS  
CORNER INSTALLATION

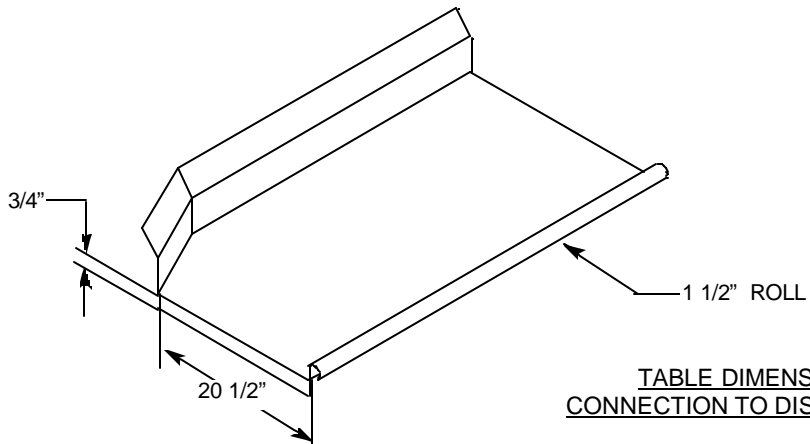

TABLE DIMENSIONS  
CONNECTION TO DISHWASHER

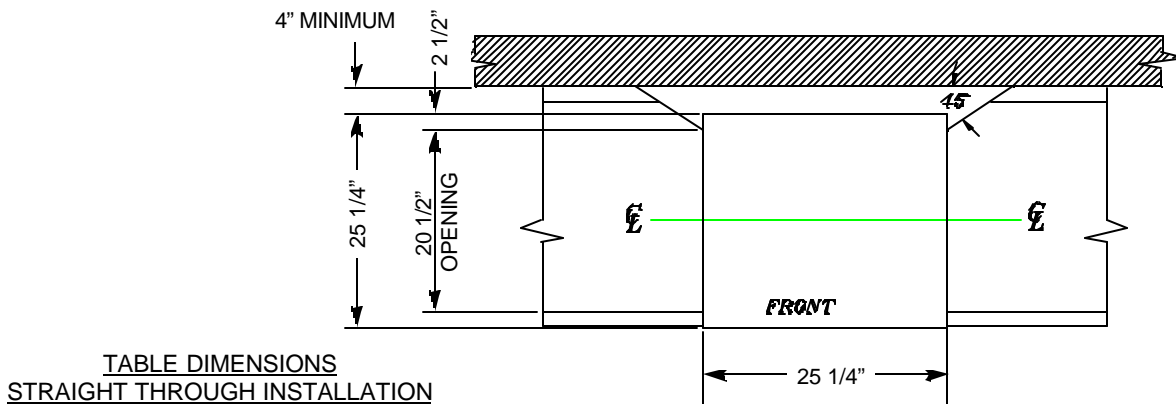

TABLE DIMENSIONS  
STRAIGHT THROUGH INSTALLATION

---

**SECTION 2:  
INSTALLATION/OPERATION  
INSTRUCTIONS**

---

## SECTION 2: INSTALLATION/OPERATION INSTRUCTIONS

### INSTALLATION INSTRUCTIONS

**VISUAL INSPECTION:** Before installing the unit, check the container and machine for damage. A damaged container is an indicator that there may be some damage to the machine. If there is damage to both the container and machine, do not throw away the container. The dishmachine has been inspected and packed at the factory and is expected to arrive to you in new, undamaged condition. However, rough handling by carriers or others may result in there being damage to the unit while in transit. If such a situation occurs, do not return the unit to Jackson; instead, contact the carrier and ask them to send a representative to the site to inspect the damage to the unit and to complete an inspection report. You must contact the carrier within 48 hours of receiving the machine. Also, contact the dealer through which you purchased the unit.

**UNPACKING THE DISHMACHINE:** Once the machine has been removed from the container, ensure that there are no missing parts from the machine. This may not be obvious at first. If it is discovered that an item is missing, contact Jackson immediately to have the missing item shipped to you.

**LEVEL THE DISHMACHINE:** The dishmachine is designed to operate while being level. This is important to prevent any damage to the machine during operation and to ensure the best results when washing ware. The unit comes with adjustable bullet feet, which can be turned using a pair of channel locks or by hand if the unit can be raised safely. Ensure that the unit is level from side to side and from front to back before making any connections.

**PLUMBING THE DISHMACHINE:** All plumbing connections must comply with all applicable local, state, and national plumbing codes. The plumber is responsible for ensuring that the incoming water line is thoroughly flushed prior to connecting it to any component of the dishmachine. It is necessary to remove all foreign debris from the water line that may potentially get trapped in the valves or cause an obstruction. Any valves that are fouled as a result of foreign matter left in the water line, and any expenses resulting from this fouling, are not the responsibility of the manufacturer.

**CONNECTING THE DRAIN LINE:** The drain for the Tempstar models covered in this manual are gravity discharge drains. All piping from the 1-1/2" FNPT connection on the wash tank must be pitched (1/4" per foot) to the floor or sink drain. All piping from the machine to the drain must be a minimum 1-1/2" NPT and shall not be reduced. There must also be an air gap between the machine drain line and the floor sink or drain. If a grease trap is required by code, it should have a flow capacity of 5 gallons per minute.

 **NOTE:** This equipment is not recommend for use with deionized water or other aggressive fluids. Use of deionized water or other aggressive fluids will result in corrosion and failure of materials and components. Use of deionized water or other aggressive fluids will void the manufacturer's warranty.

**WATER SUPPLY CONNECTION:** Ensure that you have read the section entitled "PLUMBING THE DISHMACHINE" above before proceeding. Install the water supply line (1/2" pipe size minimum) to the dishmachine line strainer using copper pipe. It is recommended that a water shut-off valve be installed in the water line between the main supply and the machine to allow access for service. The water supply line is to be capable of 25 PSI "flow" pressure at the recommended temperature indicated on the data plate. For the Tempstar GPX, the line should also have the capacity to supply 52.2 GPH @ 25 PSI "flow" pressure.

For the Tempstar HH GPX, the line should also have the capacity to supply 72 GPH @ 25 PSI "flow" pressure.

In areas where the water pressure fluctuates or is greater than the recommended pressure, it is suggested that a water pressure regulator be installed. The Tempstar models covered in this manual come with water pressure regulators as standard equipment. Please notify Jackson immediately if this component is not present on your machine.

Do not confuse static pressure with flow pressure. Static pressure is the line pressure in a "no flow" condition (all valves and services are closed). Flow pressure is the pressure in the fill line when the fill valve is opened during the cycle.

It is also recommended that a shock absorber (not supplied with the Tempstar models) be installed in the incoming water line. This prevents line hammer (hydraulic shock), induced by the solenoid valve as it operates, from causing damage to the equipment.

**WATER CONNECTION TO THE GAS BOOSTER HEATER:** Refer to page entitled "GAS BOOSTER HEATER CONNECTIONS".

---

## SECTION 2: INSTALLATION/OPERATION INSTRUCTIONS

### INSTALLATION INSTRUCTIONS

**GAS BOOSTER HEATER ELECTRICAL INSTALLATION:** The gas booster heater must have a separate electric hookup than that supplied to the dishmachine. Please refer to the manual supplied with your gas booster heater.

**GAS CONNECTION TO THE BOOSTER HEATER:** Please refer to the manual supplied with your gas booster heater.

**VENTILATION OF THE GAS BOOSTER HEATER:** Please refer to the manual supplied with your gas booster heater.

**PLUMBING CHECK:** Slowly turn on the water supply to the machine after the incoming fill line and the drain line have been installed. Check for any leaks and repair as required. All leaks must be repaired prior to placing the machine in operation.

**ELECTRICAL POWER CONNECTION:** Electrical and grounding connections must comply with the applicable portions of the National Electrical Code ANSI/NFPA 70 (latest edition) and/or other electrical codes.

Disconnect electrical power supply and place a tag at the disconnect switch to indicate that you are working on the circuit.

The dishmachine data plate is located on the right side and to the front of the machine. Refer to the data plate for machine operating requirements, machine voltage, total amperage load and serial number.

To install the incoming power lines, remove the control box cover. Install 3/4" conduit into the pre-punched holes in the back of the control box. Route power wires and connect to power block and grounding lug. Install the service wires (L1 and L2) to the appropriate terminals as they are marked on the terminal block. Install the grounding wire into the lug provided. and tighten the connections. It is recommended that "DE-OX" or another similar anti-oxidation agent be used on all power connections.

**VOLTAGE CHECK:** Ensure that the power switch is in the OFF position and apply power to the dishmachine. Check the incoming power at the terminal block and ensure it corresponds to the voltage listed on the data plate. If not, contact a qualified service agency to examine the problem. Do not run the dishmachine if the voltage is too high or too low. Shut off the service breaker and mark it as being for the dishmachine. Advise all proper personnel of any problems and of the location of the service breaker. Replace the control box cover and tighten down the screws.

## SECTION 2: INSTALLATION/OPERATION INSTRUCTIONS

### GAS BOOSTER HEATER CONNECTIONS

# ⚠ WARNING ⚠

ENSURE THAT THERE IS NO ELECTRICAL POWER APPLIED TO THE MACHINE WHEN MAKING GAS CONNECTION.

CHECK ALL GAS CONNECTIONS FOR LEAKS PRIOR TO APPLYING POWER.

THE GASES USED FOR COMBUSTION IN THIS DISH MACHINE ARE HIGHLY FLAMMABLE.  
DO NOT SMOKE AROUND THIS MACHINE.

ENSURE THAT THE AREA WHERE THIS MACHINE IS TO BE INSTALLED IS WELL-VENTILATED TO PREVENT THE BUILD-UP OF COMBUSTIBLE GASES.

ENSURE THAT ALL LOCAL HEALTH, FIRE, AND BUILDING CODES ARE BEING ADHERED TO WHEN INSTALLING THIS MACHINE. VERIFY WITH LOCAL OFFICIALS IF THERE ARE ANY QUESTIONS.

INSTALL A SHUT-OFF VALVE AT THE GAS SOURCE.

Due to the fact that each customer may have different requirements for the orientation of the gas booster heater relative to the main dishmachine, the hose lengths that connect the two units must be customized during each installation.

To prevent incorrect measurements of the hose, it is recommended to place one barbed hose fitting into the end of the uncut length of hose coil and attach that fitting to an appropriate connection. Run the hose to the corresponding connection on the other unit before cutting the hose. Use a barbed hose fitting that is screwed into the second connection on the other unit before cutting the hose. Use a barbed hose fitting that is screwed onto the second connection to gauge the correct distance. Ensure a smooth "flow" of hose without any sharp turns or kinks.

To aid in pushing the barbed hose fitting into the hose, place the fitting on a hard surface (i.e. the floor) with the barbed end of the fitting pointing upward and push the hose down onto the fitting. A small amount of lubricant (i.e. petroleum jelly) may aid in this process.

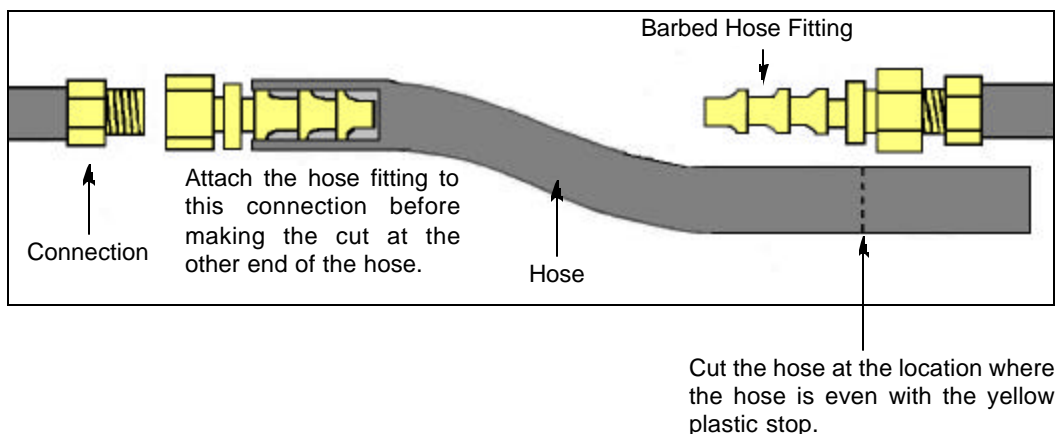

## SECTION 2: INSTALLATION/OPERATION INSTRUCTIONS

### GAS BOOSTER HEATER CONNECTIONS (CONTINUED)

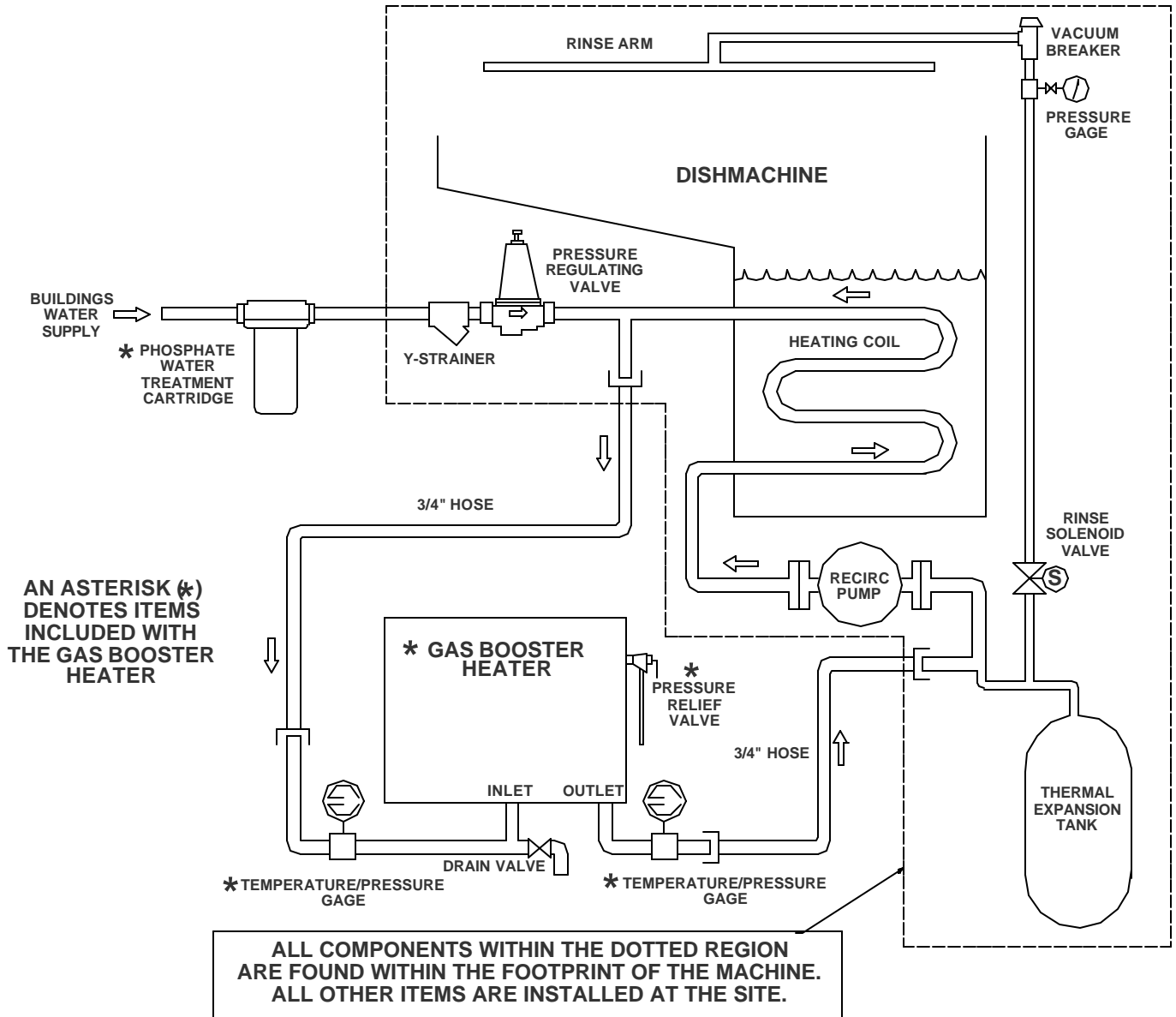

---

## SECTION 2: INSTALLATION/OPERATION INSTRUCTIONS

### OPERATION INSTRUCTIONS

**PREPARATION:** Before proceeding with the start-up of the unit, verify the following:

1. The pan strainer and pump suction strainer are in place and are clean.
2. The overflow tube and o-ring are installed.
3. That the wash and rinse arms are screwed securely into place and that their endcaps are tight. The wash and rinse arms should rotate freely.

**GAS BOOSTER HEATER OPERATION:** For all start up and operation information, please refer to the manual supplied with your gas booster heater.

**POWER UP:** To energize the unit, turn on the power at the service breaker. The voltage should have been previously verified as being correct. If not, the voltage will have to be verified.

**FILLING THE WASH TUB (TEMPSTAR GPX):** Ensure that the delime switch is in the NORMAL position, and place the power switch into the ON position. The Tempstar model should fill automatically and shut off when the appropriate level is reached (just below the pan strainer). Verify that the drain stopper is preventing the wash tub water from leaking excessively. There may be some slight leakage from the drain hole. Verify that there are no other leaks on the unit before proceeding any further. The wash tub must be completely filled before operating the wash pump to prevent damage to the component. Once the wash tub is filled, the unit is ready for operation.

**FILLING THE WASH TUB (TEMPSTAR HH GPX):** For the initial fill, ensure that the cycle selection switch is in the "AUTO" (automatic) position, and place the power switch in the "ON" position. The unit will fill automatically and run through a rinse cycle. Open the doors and verify that the water level is correct. Hereafter, the water level is controlled by the overflow tube. Verify that the drain stopper is preventing the wash tub water from draining excessively. There may be some slight leakage from the drain hole. Verify that there are no other leaks on the unit before proceeding any further. The wash tub must be completely filled before operating the wash pump to prevent damage to the component. Once the wash tub is filled, the unit is ready for operation.

**WARE PREPARATION:** Proper preparation of ware will help ensure good results and less re-washes. If not done properly, ware may not come out clean and the efficiency of the dishwasher will be reduced. It is important to remember that a dishwasher is not a garbage disposal and that simply throwing unscrapped dishes into the machine simply defeats the purpose altogether of washing the ware. Scraps should be removed from ware prior to being loaded into a rack. Pre-rinsing and pre-soaking are good ideas, especially for silverware and casserole dishes. Place cups and glasses upside down in racks so that they do not hold water during the cycle. The dishwasher is meant not only to clean, but to sanitize as well, to destroy all of the bacteria that could be harmful to human beings. In order to do this, ware must be properly prepared prior to being placed in the machine.

**DAILY MACHINE PREPARATION:** Refer to the section entitled "PREPARATION" at the top of this page and follow the instructions there. Afterwards, check that all of the chemical levels are correct and/or that there is plenty of detergent available for the expected workload.

**WARM-UP CYCLES:** For a typical daily start-up, it may be necessary to run the machine through 3 cycles to ensure that all of the cold water is out of the system and to verify that the unit is operating correctly. To cycle the machine, ensure that the power is on and that the tub has filled to the correct level. Lift the doors and the cycle light will illuminate. When the light goes out, close the doors, the unit will start, run through the cycle, and shut off automatically. Repeat this two more times. The unit should now be ready to proceed with the washing of ware.

**WASHING A RACK OF WARE:** To wash a rack, open the doors completely (being careful for hot water that may drip from the doors) and slide the rack into the unit. Close the doors and the unit will start automatically. Once the cycle is completed, open the door (again watching for the dripping hot water) and remove the rack of clean ware. Replace with a rack of soiled ware and close the doors. The process will then repeat itself.

---

## SECTION 2: INSTALLATION/OPERATION INSTRUCTIONS

### OPERATION INSTRUCTIONS (CONTINUED)

**OPERATIONAL INSPECTION:** Based upon usage, the pan strainer may become clogged with soil and debris as the workday progresses. Operators should regularly inspect the pan strainer to ensure it has not become clogged. If the strainer does, it will reduce the washing capability of the machine. Instruct operators to clean out the pan strainer at regular intervals or as required by work load.

**SHUTDOWN AND CLEANING:** At the end of the workday, close the doors. When the unit completes the cycle, turn the power switch to the OFF position and open the doors. Remove and clean the pan strainer. Remove the drain stopper from the tub and allow the tub to drain (NOTE: the wash tank water will be hot so caution is advised). Once the wash tub is drained, remove the pump suction strainer. Remove soil and debris from the strainer and set to the side. Unscrew the wash and rinse arms from their manifolds. Remove the endcaps and flush the arms with water. Use a brush to clean out the inside of the arms. If the nozzles appear to be clogged, use a toothpick to remove the obstruction. Wipe the inside of the unit out, removing all soil and scraps. Reassemble the wash and rinse arms and replace them in the unit. The arms only need to be hand tight, do not use tools to tighten them down. Reinstall the drain stopper and strainers and close the doors.

**WATER CONSUMPTION ISSUES AND EFFICIENCY:** The Tempstar HH GPX provides you, the customer, with the ability to control the hourly rack capacity of the machine. Extending the wash cycle to wash severely soiled ware, such as mixing bowls, does not increase the machine's water consumption. However, selecting a longer time cycle does lower the amount of dishes the machine will be able to wash per hour. It is important for operators to select the correct wash cycle depending on the amount of washing required. Not every rack of dishes requires the machine to be set on the longest wash cycle!

Using good prescrapping procedures and observing the results of individual racks of ware, operators will soon gain the experience and knowledge required to ensure that the Tempstar HH GPX operates at peak efficiency for your needs.

Water hardness and detergent usage will also effect the results of the Tempstar HH GPX. This manual provides a page entitled "Detergent Control" for your reference. It is recommended that owners and operators take the time to carefully review this section in order to ensure that everything is done to make sure the Tempstar HH GPX operates at peak performance!

---

## **SECTION 3: PREVENTATIVE MAINTENANCE**

---

## SECTION 3: PREVENTATIVE MAINTENANCE

### PREVENTATIVE MAINTENANCE

---

The dishmachines covered in this manual are designed to operate with a minimum of interaction with the operator. However, this does not mean that some items will not wear out in time. Jackson highly recommends that any maintenance and repairs not specifically discussed in this manual should be performed by **QUALIFIED SERVICE PERSONNEL ONLY**. Performing maintenance on your dishmachine may void your warranty if it is still in effect, so if you have a question or concern, do not hesitate to contact one of the **QUALIFIED SERVICE AGENCIES** listed in the back of this manual.

There are many things that operators can do to prevent catastrophic damage to the dishmachine. One of the major causes of component failure has to do with prescrapping procedures. A dishmachine is not a garbage disposal; any large pieces of material that are put into the machine shall remain in the machine until they are either broken up (after spreading out on your ware!) or physically removed. Strainers are installed to help catch debris, but they do no good if they are clogged. Have operators regularly inspect the pan strainers to ensure (1) that they are free of soil and debris and (2) they are laying flat in the tub.

When cleaning out strainers, do **NOT** beat them on waste cans. The strainers are made of metal and can be forgiving; but once severe damage is done, it is next to impossible for the strainer to work in the way it was designed to. Wipe out strainers with a rag and rinse under a faucet if necessary. For stubborn debris, a toothpick should be able to dislodge any obstructions from the perforations. Always ensure that strainers are placed back in the machine before operation and that they lay flat in the tub.

You may wish to also refer to the page entitled "Detergent Control" in order to learn more about how your water hardness will effect the performance of your machine. Hard water makes dishmachines work harder and decreases efficiency.

Again, it is important to remind operators that trying to perform corrective maintenance on the dishmachine could lead to larger problems or even cause harm to the operator. If a problem is discovered; secure the dishmachine using proper shut down procedures as listed in this manual and contact a **QUALIFIED SERVICE AGENCY** as listed in the back of this manual.

Some problems, however, may have nothing to do with the machine itself and no amount of preventative maintenance is going to help. A common problem has to do with temperatures being too low. Verify that the water temperatures coming to your dishmachine match the requirements listed on the machine data plate. There can be a variety of reasons why your water temperature could be too low and you should discuss it with a **QUALIFIED SERVICE AGENCY** to determine what can be done.

By following the operating and cleaning instructions in this manual, you should get the most efficient results from your machine. As a reminder, here are some steps to take to ensure that you are using the dishmachine the way it was designed to work:

1. Ensure that the water temperatures match those listed on the machine data plate.
2. Ensure that all strainers are in place before operating the machine.
3. Ensure that all wash and/or rinse arms are secure in the machine before operating.
4. Ensure that drains are closed/sealed before operating.
5. Remove as much soil from dishes by hand as possible before loading into racks.
6. Do not overfill racks.
7. Ensure that glasses are placed upside down in the rack.
8. Ensure that all chemicals being injected to machine have been verified as being at the correct concentrations.
9. Clean out the machine at the end of every workday as per the instructions in the manual.
10. Always contact a **QUALIFIED SERVICE AGENCY** whenever a serious problem arises.
11. Follow all safety procedures, whether listed in this manual or put forth by local, state or national codes/regulations.

---

## **SECTION 4: TROUBLESHOOTING**

---

## SECTION 4: TROUBLESHOOTING

### COMMON PROBLEMS



**WARNING:** Inspection, testing and repair of electrical equipment should be performed only by qualified service personnel. Certain procedures in this section require electrical tests or measurements while power is applied to the machine. **Exercise extreme caution at all times.** If test points are not easily accessible, disconnect power, attach test equipment and reapply power to test. When replacing electrical parts, disconnect power at source circuit breaker.

**Problem: Dishmachine will not fill after the door is close. Power “ON” light is illuminated.**

1. Faulty rinse solenoid valve. Repair or replace valve as required.
2. Faulty door switch. Verify the wiring of the switch; if correct, replace the switch.
3. Fouled/faulty high level probe. Clean probe if fouled. If clean, and still not working, replace.

**Problem: Dishmachine will not fill after the door is closed. Power “ON” light is not illuminated.**

1. Service breaker tripped. Reset. If the breaker trips again, contact an electrician to verify the amp draw of the machine.
2. Machine not connected to power source. Verify that the machine has been properly connected to the power source.
3. Faulty power source. Verify the wiring of the switch; if correct, replace switch.

**Problem: Dishmachine will not run after the door is closed. Power “ON” light is illuminated and the unit is filling.**

1. Timer motor is faulty. Verify that the timer is rotating. If not, check to see that the motor is receiving power. If so, replace the motor and/or timer assembly.
2. Wash motor faulty/damaged. Verify that the wash motor is getting power. If so, replace the motor.
3. Wash motor contactor faulty. Check for continuity; if contacts are open, replace the contactor.

**Problem: (TEMPSTAR GPX) Dishmachine runs continuously in the wash cycle.**

1. Machine is in Delime mode. Flip NORMAL/DELIME switch to NORMAL mode.
2. Timer motor is faulty. Verify that the timer is rotating. If not, check to see that the motor is receiving power. If so, replace the motor and/or timer assembly.
3. Cam timer jammed by obstruction. Remove obstruction.

**Problem: (TEMPSTAR HH GPX) Dishmachine runs continuously in the wash cycle.**

1. Machine is in delime mode. Change Operation Mode from DELIME to NORMAL position.
2. Wash cycle delay timer is faulty. During the wash cycle, the cam timer will move for the first 30 seconds of the wash cycle. The cycle delay timer will then cause the cam timer to stop, in order to increase the length of the wash cycle. The red light on the delay timer is in control of the cam timer. If the red light is not turning on (only during cycles B, C or D), replace the cycle timer.
3. Wash cycle delay timer settings not correctly adjusted. If the wash cycle delay timer and rotating cam timer are working correctly, the time cycles on the delay timer may be incorrectly adjusted. Adjust the delay potentiometer corresponding to the B, C or D cycle. Rerun the appropriate cycle and see if the adjustment has made any change in the length of the cycle. If not, replace the cycle delay timer.
4. Cam timer is faulty. Confirm that the wash cycle delay timer is functioning correctly (see above). Confirm that the timer motor is receiving power. If it is, replace the motor and/or timer assembly. Make sure there are no obstructions which limit the rotation of the cam timer.

**Problem: Wash or rinse heater does not work.**

1. Faulty heater element. Check element for continuity; if open, replace the heater.
2. Faulty heater contactor. Replace the contactor.
3. Misadjusted/faulty thermostat(s). Verify operation and setting of thermostats, replace if necessary.

**Problem: Dishmachine fill slowly and/or the rinse is weak.**

1. Clogged or obstructed rinse arms. Remove and clean the rinse arms.
2. Low incoming water pressure. Adjust the water pressure regulator to ensure that there is  $20 \pm 5$  PSI flow.
3. Y-strainer is clogged. Clean out the Y-strainer.

---

## SECTION 4: TROUBLESHOOTING

### COMMON PROBLEMS (CONTINUED)

---

**Problem: Rinse water not reaching required temperature.**

1. Faulty rinse heater. Check element for continuity; if open, replace heater.
2. Misadjusted/faulty thermostat(s). Verify operation and setting of thermostats, replace if necessary.
3. Rinse thermometer is defective. Replace thermometer.

**Problem: Wash water is not reaching required temperature.**

1. Faulty wash heater. Check element for continuity; if open, replace the heater.
2. Misadjusted/faulty thermostat(s). Verify operation and setting of thermostats, replace if necessary.
3. Wash thermometer is defective. Replace thermometer.

**Problem: Doors will not close completely.**

1. Improper spring tension. Adjust spring tension as required by loosening (not removing) spring bolt nuts and adjusting the tension. Tighten nuts back when done.
2. Obstruction in door channel. Remove the obstruction.
3. Doors are not square with frame. Adjust the frame to accommodate the doors.

**Problem: Doors are hard to open.**

1. Improper tension on door springs. Adjust tension.
2. Door guides worn or obstructed. Replace if worn or cracked. Clean the door guides.
3. Doors not positioned correctly. Adjust the door positioning.
4. Dish table may be pinching the door runners. Adjust the table position.

**Problem: Water leaks at the wash pump.**

1. Wash pump seal defective. Replace the seal.
2. Petcock or pump drain (if equipped) not shut/tight. Close or tighten.
3. Loose hoses (hose clamps) on the wash pump. Tighten the hose clamps.

**Problem: Will not rinse during autocycle.**

1. Defective rinse solenoid. Repair or replace the rinse solenoid as required.
2. Faulty fill microswitch. Replace microswitch.
3. No water to the machine. Verify that there is water a  $20 \pm 5$  PSI connected to the machine.

**Problem: Dishes are not coming clean.**

1. Machine temperatures are not up to the minimum requirements. Verify that incoming water, rinse water, and wash water match the required temperatures as listed on the machine data plate.
2. No detergent/too much detergent. Adjust detergent concentration as required for the amount of water held by the machine.
3. Solid dispenser canister is empty. Replace the canister.

---

# **SECTION 5: SERVICE PROCEDURES**

---

## SECTION 5: SERVICE PROCEDURES

### RINSE SOLENOID VALVE REPAIR PARTS KIT

These dishmachines are equipped with electrical solenoid valves to allow for automatic fill and rinse. These valves are designed to specific tolerances and design aspects that must be met in order to function properly.

Ecolab offers repair kits for replacing some of the wear items associated with solenoid valves which will allow you to save money in that replacement of these parts can take place *without* removing the solenoid valve from the plumbing assembly.

The instructions provided here are for maintenance personnel only. Unauthorized persons should not attempt any of the steps contained in these instructions.

**Warning: many of the instructions and steps within this document require the use of tools. Only authorized personnel should ever perform any maintenance procedure on the dishmachine!**

### PREPARATION

1. Power must be secured to the unit at the service breaker. Tag or lock out the service breaker to prevent accidental or unauthorized energizing of the machine.
2. Ensure that incoming water to the machine is secured either by use of a shut-off valve or disconnecting the incoming water line.

### TOOLS REQUIRED

The following tools will be needed to perform this maintenance evolution:

1. Small flathead screwdriver
2. Medium flathead screwdriver
2. Needle nose pliers
3. 5/16" nutdriver
4. Channel locks
5. 12" pipe wrench

### TIME REQUIRED

It is estimated that it will take (1) person twenty minutes to perform this task, not including all of the items indicated in the section entitled "PREPARATION".

### IMPORTANT NOTES

1. Read these instructions thoroughly before attempting this maintenance evolution. Become familiar with the parts and what actions need to be taken. This will save time in the long run!
2. The procedures demonstrated in this manual are shown being performed on an AJ-44CE rack conveyor dish-machine. The actual maintenance steps, however, apply to any Parker style solenoid valve found on a Jackson dish-machine.

### STEPS

1. Remove the top screw with the 5/16" nutdriver. Remove the screw and the data plate and set to the side.



Removing the top screw

2. With the top screw and data plate removed, grasp the solenoid coil and gently pull up. The coil should slide up, allowing you to remove it from the valve bonnet. If you are wanting to replace the coil, continue on with Step 3. If you are wanting to replace some of the internal components of the valve, proceed to step 12.



Removing the coil

3. **NOTE:** Replacing the solenoid coil requires working with the wiring of your machine. It is important that all wiring maintenance be performed by qualified personnel. Always verify the wiring steps presented in this instruction with the schematic that shipped with the unit. A current schematic can also be found in the unit's installation manual. Before beginning any step that involves working with wiring, ensure that the steps located in the section entitled "Preparation" have been performed. Power must be secured to the machine at the service breaker. Failure to do so could result in severe injury to maintenance personnel.

---

## SECTION 5: SERVICE PROCEDURES

### RINSE SOLENOID VALVE REPAIR PARTS KIT (CONTINUED)

---

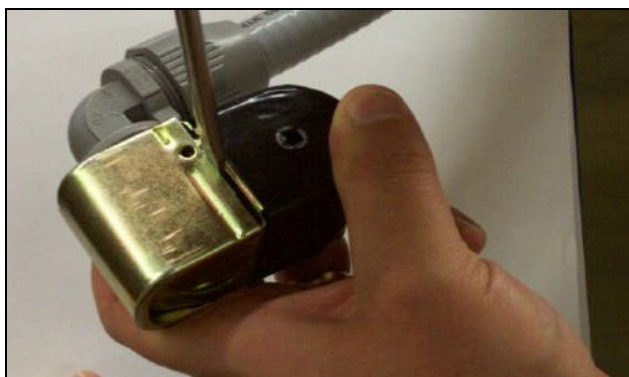

Prying open the coil wire cover

4. When replacing the coil, ensure that when removing the coil wire cover that care is taken not to damage the wires inside. Using the medium flathead screwdriver, gently use it to open the cover enough to where it could be pulled off.

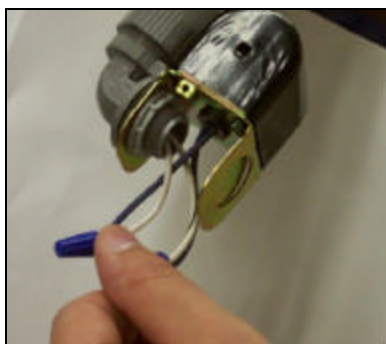

Straightening the wires

5. Once the coil wire cover has been removed and set to the side, take the internal wires and pull them out straight.



Removing the wire nuts

6. Remove the wire nuts from the wires and separate them.



Loosening the conduit nut

7. Using a pair of channel locks, gently loosen the conduit retaining ring for the conduit nut. Once it is loosened, use your fingers to unscrew and remove it.

8. Pull the conduit away and discard the bad coil. Take the new coil and attach the conduit, reinstall & tighten the conduit nut, and pull the wires through so that you will be able to wire the valve back up.

9. Reconnect the wires from the conduit to the wires from the solenoid as they had been connected previously. Ensure that the wire nuts are on tight.

10. Slide the coil wire cover back on, taking care not to damage the wires.

11. If you are done performing maintenance on the valve, continue on to step 23. Otherwise, please go on to step 12.L



Loosening the valve bonnet

12. To remove the valve bonnet, grasp it with the jaws of the pipe wrench and turn to the left. **Note:** on some models you may have to remove the valve in order to perform this and any further steps. Be careful not to damage the plumbing assembly. Only use the pipe wrench enough to where you can spin the valve bonnet off with your hand.

---

## SECTION 5: SERVICE PROCEDURES

### RINSE SOLENOID VALVE REPAIR PARTS KIT (CONTINUED)

---



Removing the valve bonnet

13. Slowly remove the valve bonnet. **Note:** The spring for the plunger is located directly under the bonnet and may come free if you are not careful. Remove the plunger, spring and valve bonnet and place to the side.



Removing the diaphragm

17. Remove the diaphragm retainer and then the diaphragm itself. Many problems associated with a solenoid valve can be traced to a clogged pilot port in the diaphragm.

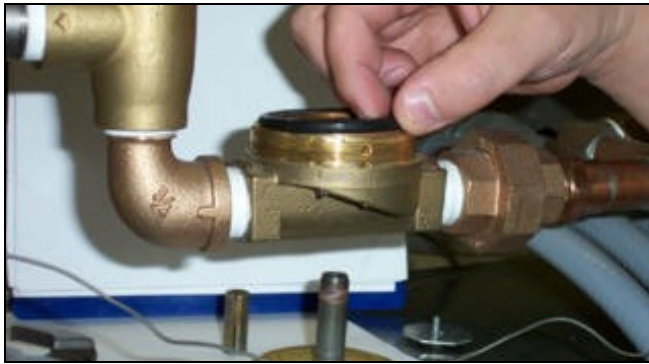

Removing the O-ring

14. Remove the O-ring and inspect it. If it has any tears or cuts or excessive flat spaces, it should be replaced.

15. Examine the threads for the valve bonnet. Check them for scoring or signs of damage. Take a cloth and clean them out to remove any foreign particles that might get lodged in the threads and cause a leak. Severely damaged threads should not be repaired; instead it is recommended that the entire valve should be replaced. These instructions do not provide information on replacing the solenoid valve.

16. **Note:** Even though an O-ring may not appear damaged, it is a good idea to go ahead and replace it if you have a new one. This will help ensure that your valve remains leak-free in the future!



Pointing out the extension hole

18. As indicated in the photo above, the extension hole can become clogged. If it is difficult to clean out, you can use a heated straight pin to push through the hole. The center hole, the pilot port, must also be clear. If the diaphragm is torn or bent in any way, it must be replaced.

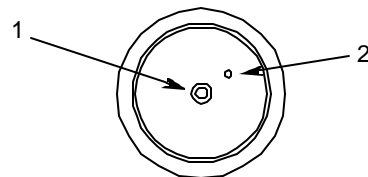

Diaphragm showing (1) pilot port and (2) extension hole

---

## SECTION 5: SERVICE PROCEDURES

### RINSE SOLENOID VALVE REPAIR PARTS KIT (CONTINUED)

---



Removing the screen retainer

19. Using the small flathead screwdriver, lift out the screen retainer. Verify that the holes in it are free of clogs and debris.



Removing the mesh strainer screen

20. Again using the small flathead screwdriver, carefully remove the mesh screen from inside the valve body. The screen should be taken and rinsed out to remove any debris fouling it.

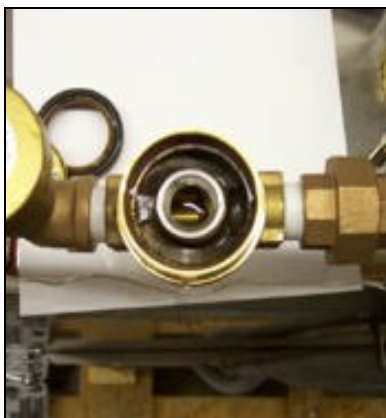

View inside the solenoid valve body

21. With the mesh screen removed, look down into the valve and verify it is not clogged. Remove any foreign objects from the valve body that would obstruct flow.

22. Reassemble the valve, reversing the steps needed to take it apart. Replace defective replacement parts with new parts from ordered kits. Ensure that components are sufficiently tightened to prevent leakage.

### **AFTER MAINTENANCE ACTIONS**

Reconnect the incoming water (if disconnected) and turn on. Then restore power to the unit. Run the unit for at least 10 minutes to ensure there are no leaks. If any problems arise please contact your Jackson representative.

### **SPECIAL PARTS**

Plunger and Spring Replacement Kit  
06401-003-07-40

Diaphragm and O-Ring Replacement Kit (3/4")  
06401-003-07-42

110V Coil and Housing  
06401-003-07-43

---

## SECTION 5: SERVICE PROCEDURES

### VACUUM BREAKER REPAIR PARTS KIT

These dishmachines are equipped with vacuum breakers to serve as back-flow prevention devices. ASSE requirements specify what type of back-flow prevention is necessary on dishmachines. Vacuum breakers, unlike air gaps, have certain parts that have specific tolerances and design aspects that must be met in order to function properly.

Ecolab offers repair kits for replacing some of the wear items associated with vacuum breakers which will allow you to save money in that replacement of these parts can take place *without* removing the vacuum breaker from the plumbing assembly.

The instructions provided here are for maintenance personnel only. Unauthorized persons should not attempt any of the steps contained in these instructions.

**Warning: many of the instructions and steps within this document require the use of tools. Only authorized personnel should ever perform any maintenance procedure on the dishmachine!**

### PREPARATION

1. Power must be secured to the unit at the service breaker. Tag or lock out the service breaker to prevent accidental or unauthorized energizing of the machine.

2. Ensure that incoming water to the machine is secured either by use of a shut-off valve or disconnecting the incoming water line.

### TOOLS REQUIRED

The following tools will be needed to perform this maintenance evolution:

1. Small flathead screwdriver
2. Needle nose pliers

### TIME REQUIRED

It is estimated that it will take (1) person twenty minutes to perform this task, not including all of the items indicated in the section entitled "PREPARATION".

### IMPORTANT NOTES

1. Read these instructions thoroughly before attempting this maintenance evolution. Become familiar with the parts and what actions need to be taken. This will save time in the long run!

### STEPS

1. **Note:** These instructions only apply to vacuum breakers (1/2" NPT and 3/4" NPT) as pictured below. The repair kits indicated in these instructions will only work on those style of back-flow preventers. If you have a machine with a different style of vacuum breaker, contact your Ecolab representative about replacement components.



Vacuum breaker

2. **Note:** Even though the photos in these instructions show a vacuum breaker that has been removed from the plumbing assembly, these maintenance steps could be performed with it installed so long as the requirements in the section entitled "PREPARATION" have been met.

3. Remove the top cap by gripping firmly and turning to the left. The cap should come off after a few turns.



Removing the cap

4. Set the cap to the side.

5. Using the needle nose pliers, gently lift out the plunger and set to the side. Examine the brass seating surface inside the vacuum breaker. The plunger is required to sit flat on this surface so it must be free of defects, imperfections and the like. If there is debris, remove it. If it is chipped or cracked then the vacuum breaker must be replaced. Failure to do so may result in the vacuum breaker not working according to its design and could result in damage to the dishmachine.

---

## SECTION 5: SERVICE PROCEDURES

### VACUUM BREAKER REPAIR PARTS KIT (CONTINUED)

---



Removing the plunger

6. Your repair kit comes with a new plunger. Examine the old one and ensure that the mating surface is not damaged or cut. Also inspect the rubber seal on the top of the plunger to ensure it is in good condition and not torn.



Examining the seal ring on the plunger



Examining the plunger seating surface

7. If any of these conditions are present, replace the old plunger with the new one from your kit. Verify that the new plunger is also free from defects. If it is not, contact your Ecolab representative immediately.

8. The plunger should drop into the vacuum breaker and seat. Ensure it is not flipped upside down (the orange seal ring should be up towards the top of the vacuum breaker).

9. Pick up the cap and examine it. With a soft towel, remove any grit, grime or debris that may have gotten caught in the threads of both the cap retainer or the vacuum breaker body. There is an O-ring that should be present on the cap retainer as well. Regardless of the condition of the plunger, this O-ring should be replaced once the cap is removed. Using a small flathead screwdriver, remove the old O-ring.



Replacing the O-ring

10. With the new O-ring in place, screw the cap back on the vacuum breaker body. The cap needs to only be hand tight (snug).

### **AFTER MAINTENANCE ACTIONS**

1. Reconnect the incoming water (if disconnected) and turn on. Then restore power to the unit. Run the unit for at least 10 minutes to ensure there are no leaks. If any problems arise please contact your Jackson representative.

### **SPECIAL PARTS**

To order the kit with components and instructions:

Components of 1/2" Repair Kit  
06401-003-06-23

Components of 3/4" Repair Kit  
06401-003-06-24

---

## **SECTION 6: PARTS SECTION**

**SECTION 6: PARTS SECTION**  
**TEMPSTAR GPX CONTROL BOX ASSEMBLY**

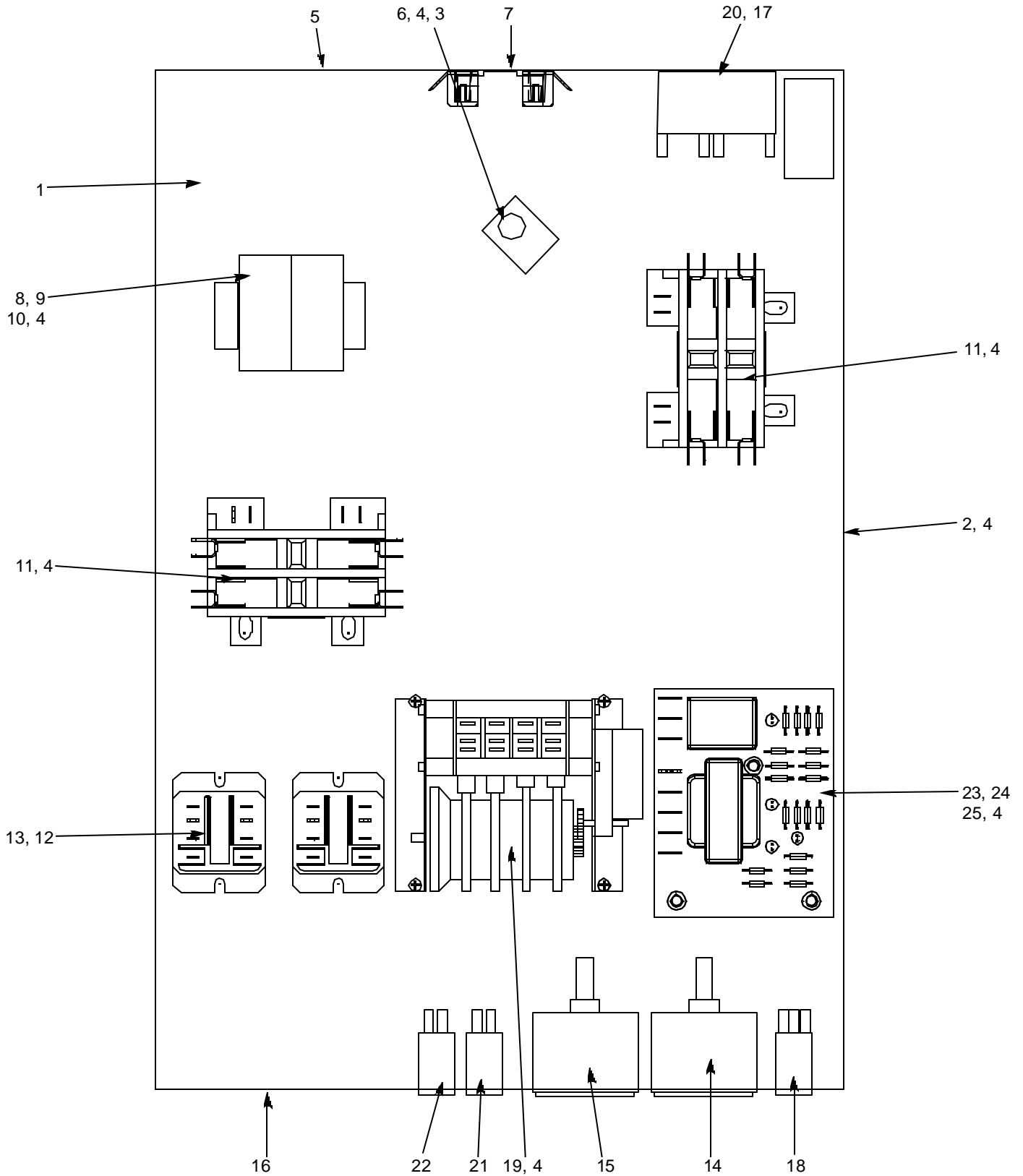

---

**SECTION 6: PARTS SECTION**  
**TEMPSTAR GPX CONTROL BOX ASSEMBLY (CONTINUED)**

---

<b>ITEM</b>	<b>QTY</b>	<b>DESCRIPTION</b>	<b>Mfg. No.</b>
1	1	Control Box Weldment	05700-002-57-08
2	1	Terminal Board, Dispenser	05940-001-97-91
3	1	Decal, Ground	09905-011-86-86
4	6	Locknut, 10-24 S/S Hex with Nylon Insert	05310-373-01-00
5	4	Plug, Heyco	05975-011-47-81
6	1	Wire Lug	05940-200-76-00
7	1	Decal, Use Copper Conductors	09905-011-47-35
8	1	Decal, L1, L2, L3	09905-101-12-66
9	2	Curtis Block	05940-500-02-19
10	1	Terminal Track	05700-000-43-60
11	2	Contactator	05945-109-03-69
12	8	Locknut, 6-32 S/S Hex with Nylon Insert	05310-373-03-00
13	2	Relay	05945-111-47-51
14	1	Rinse Thermometer	06685-111-68-48
15	1	Wash Thermometer	06685-111-68-49
16	1	Decal, Tempstar GPX	09905-002-31-84
17	1	Decal, Delime/Normal	09905-011-34-96
18	1	Switch	05930-002-43-44
19	1	Timer, 4 CKT 60Hz	05945-303-31-00
20	1	Switch, Wash	05930-301-21-18
21	1	Light, Red	05945-111-44-45
22	1	Light, Green	05945-111-44-43
23	1	Liquid Level Control Board	06680-200-08-21
24	4	Screw, 6-32 x 5/8" S/S	05305-011-39-85
25	1	Bracket, LLC Board Mounting	05700-002-13-22
26*	1	Cover, Control Box	05700-002-23-03
27*	1	Decal, Warning - Disconnect Power	09905-100-75-93
28*	1	Bolt, 10-32 x 1/2" Slotted Truss Head	05305-173-12-00
29*	4	Leg, Control Box Support	05700-002-33-05
30*	4	Screw, 1/4"-20 x 2 3/4" S/S Hex Head Cap	05305-274-13-00
31*	4	Washer, 1/4"-20 I.D.	05311-174-01-00
32*	4	Locknut, 1/4"-20 S/S Hex with Nylon Insert	05310-374-01-00

\* Represents an item not shown.

**SECTION 6: PARTS SECTION**  
**TEMPSTAR HH GPX CONTROL BOX ASSEMBLY**

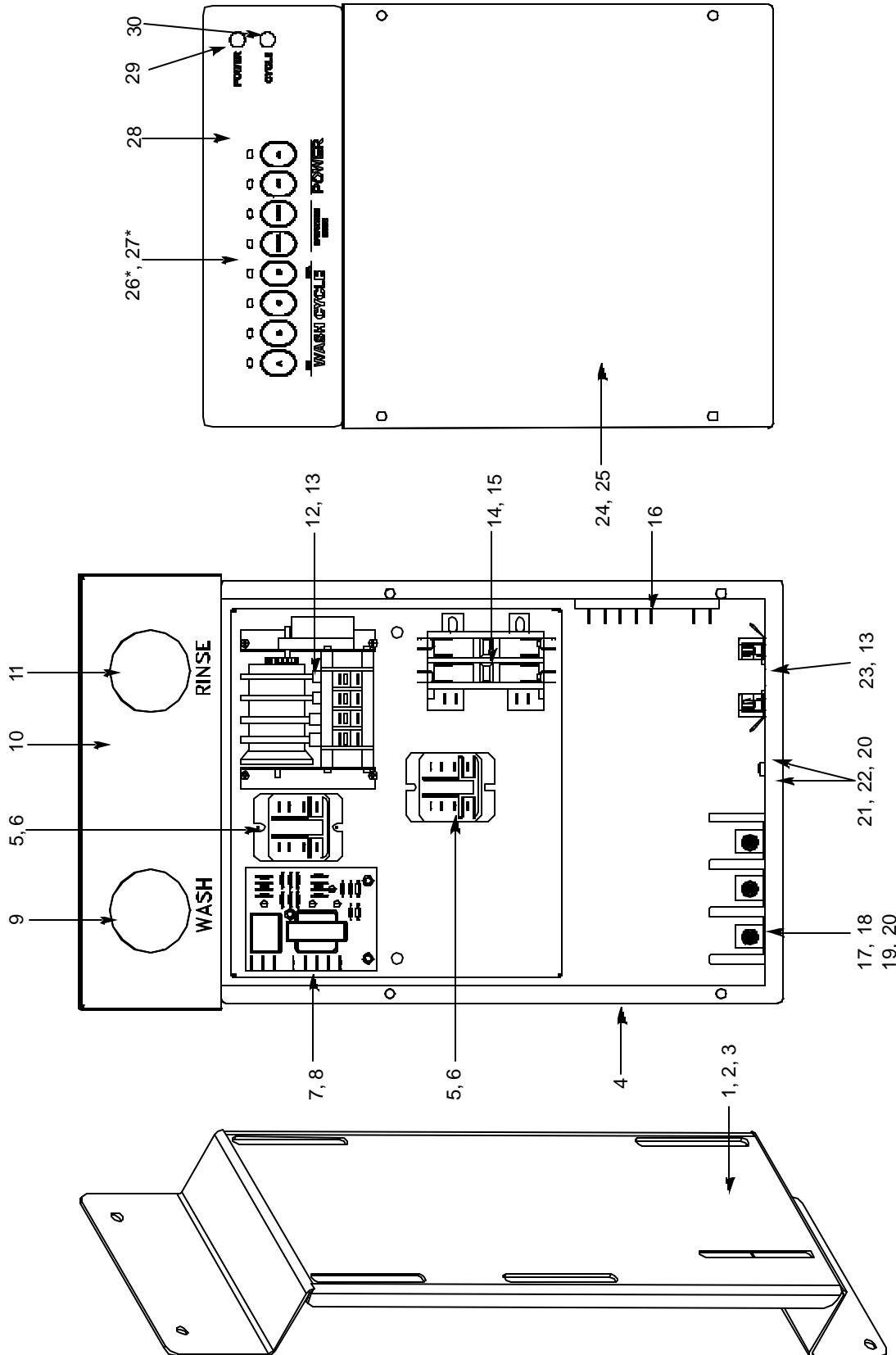

---

## SECTION 6: PARTS SECTION

### TEMPSTAR HH GPX CONTROL BOX ASSEMBLY (CONTINUED)

ITEM	QTY	DESCRIPTION	Mfg. No.
1	1	Bracket, Electrical Box Mounting	05700-002-18-48
2	9	Locknut, 1/4"-20 S/S Hex with Nylon Insert	05310-374-01-00
3	9	Washer, 1/4"-20 I.D. S/S	05311-174-01-00
4	1	Control Box Weldment	05700-002-06-48
5	2	Relay	05945-111-47-51
6	4	Screw, 10-32 x 1/2" Phillips Pan Head with Washer	05305-002-32-37
7	1	Liquid Level Control	06680-200-08-21
8	3	Screw, 6-32 x 5/8"	05305-011-39-85
*	1	Bracket, LLC Board	05700-002-13-22
9	1	Thermometer, 48 Lead	06685-111-68-48
10	1	Decal, Control Box Gauge	09905-002-00-45
11	1	Thermometer, 96 Lead	06685-111-68-49
12	1	Timer, 4CKT 208-230V Single REV	05945-303-31-00
13	8	Screw, 6-32 x 3/8" SEMS with External Tooth Washer	05305-002-25-91
14	2	Contact, 2 Pole 220V 20AMP	05945-109-03-69
15	3	Screw, 10-32 x 3/8" Phillips Pan Head	05305-173-26-00
16	1	Timer, Cycle Delay	05945-002-13-78
17	1	Curtis Block	05940-500-02-19
18	1	Decal, L1, L2, L3	09905-101-12-66
19	1	Decal, Copper Conductors	09905-011-47-35
20	4	Locknut, 10-24 S/S Hex with Nylon Insert	05310-373-01-00
21	1	Wire Lug	05940-200-76-00
22	1	Terminal Board, Dispenser	05940-001-97-91
22	1	Terminal Track	05700-000-43-60
23	1	Decal, Ground	09905-011-86-86
24	1	Cover, Control Box Weldment	05700-002-06-52
25	4	Bolt, 10-32 x 1/2"	05305-173-26-00
26*	1	Switch, 8 Button Tap Touch	05930-001-99-51
27*	1	Spacer, Switch Panel	05700-002-50-02
28	1	Decal, Control Box Cover	09905-002-31-84
29	1	Light, Red	05945-504-07-18
30	1	Light, Green	05945-504-08-18
*	1	Cover, Dielectric Control Panel	05700-021-50-89

\* Represents an item not shown.

## SECTION 6: PARTS SECTION

### TEMPSTAR GPX HOOD ASSEMBLY

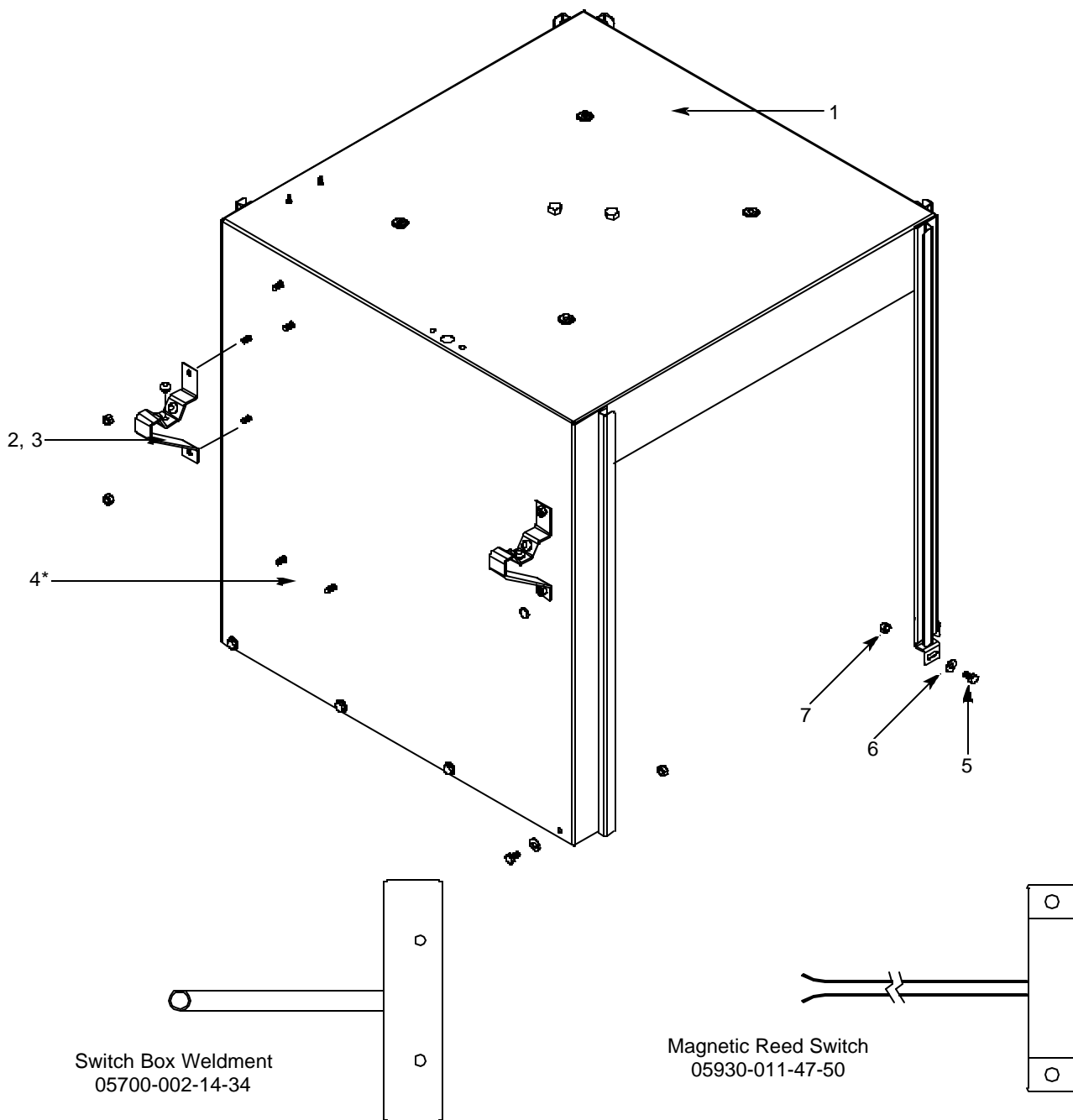

ITEM	QTY	DESCRIPTION	Mfg. No.
1	1	Hood, Single Piece Weldment	05700-002-57-02
2	2	Bracket, Cantilever Support	05700-031-88-00
3	6	Wear Button .50 Dia.	05700-011-88-01
4*	1	Conduit Bracket (not shown)	05700-021-70-88
5	8	Bolt, 1/4"-20 x 1/2" S/S Hex Head	05305-274-02-00
6	8	Washer, 1/4" I.D. S/S	05311-174-01-00
7	14	Locknut, 1/4"-20 S/S Hex with Nylon Insert	05310-374-01-00

## SECTION 6: PARTS SECTION

### TEMPSTAR HH GPX HOOD ASSEMBLY

\* Represents an item not shown.

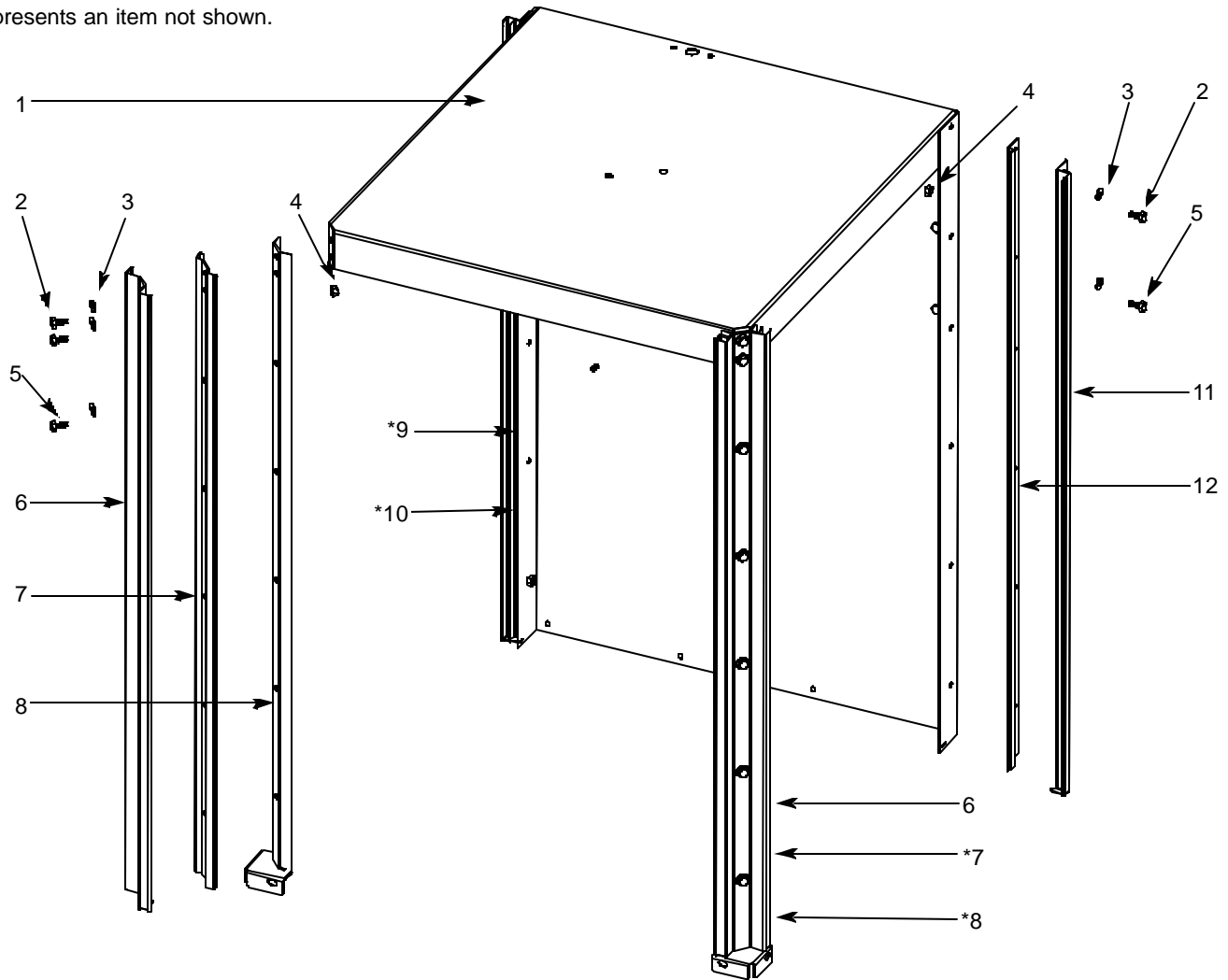

ITEM	QTY	DESCRIPTION	Mfg. No.
1	1	Hood Weldment	05700-002-01-23
2	6	Bolt, 1/4"-20 X 5/8" Long Hex	05305-274-24-00
3	26	Washer, 1/4" ID S/S	05311-174-01-00
4	26	Locknut, 1/4"-20 S/S Hex with Nylon Inserts	05310-374-01-00
5	26	Bolt, 1/4"-20 X 1/2" Long Hex	05305-274-02-00
6	2	Right/Left Front Outer Door Guide	05700-031-76-85
7	2	Right/Left Front Inner Door Guide	05700-031-76-82
8	2	Right/Left Front Hood Support Weldment	05700-002-17-68
9	1	Left Rear Outer Door Guide	05700-031-76-34
10	1	Left Rear Inner Door Guide	05700-031-76-33
11	1	Right Rear Outer Door Guide	05700-031-76-35
12	1	Right Rear Inner Door Guide	05700-031-76-32

**SECTION 6: PARTS SECTION**  
**FRAME ASSEMBLIES**

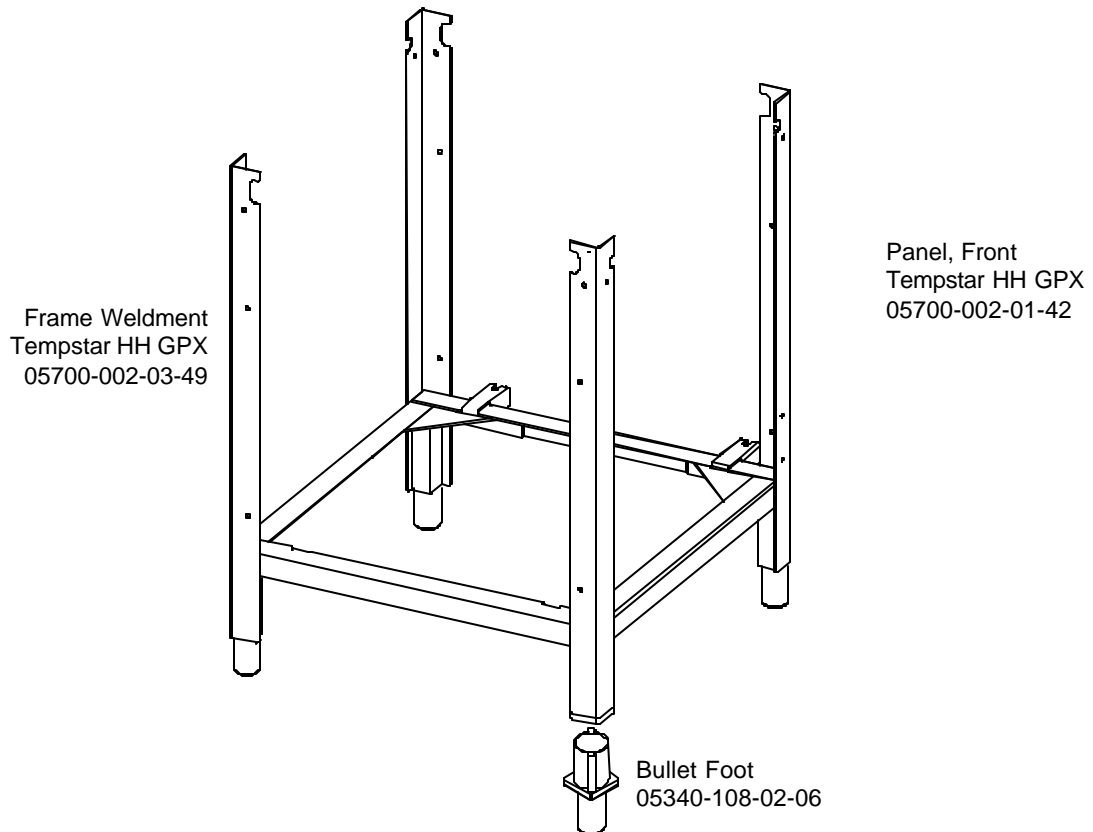
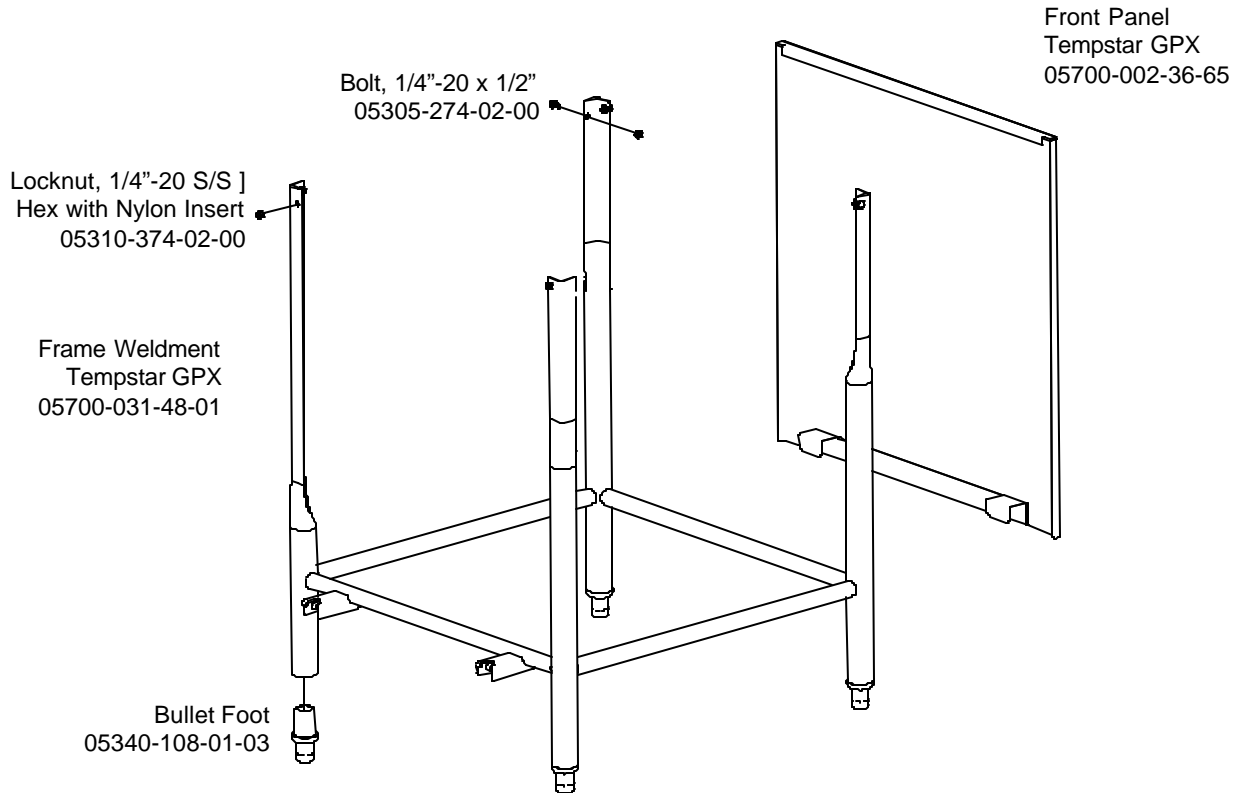

# SECTION 6: PARTS SECTION

## TUB ASSEMBLY

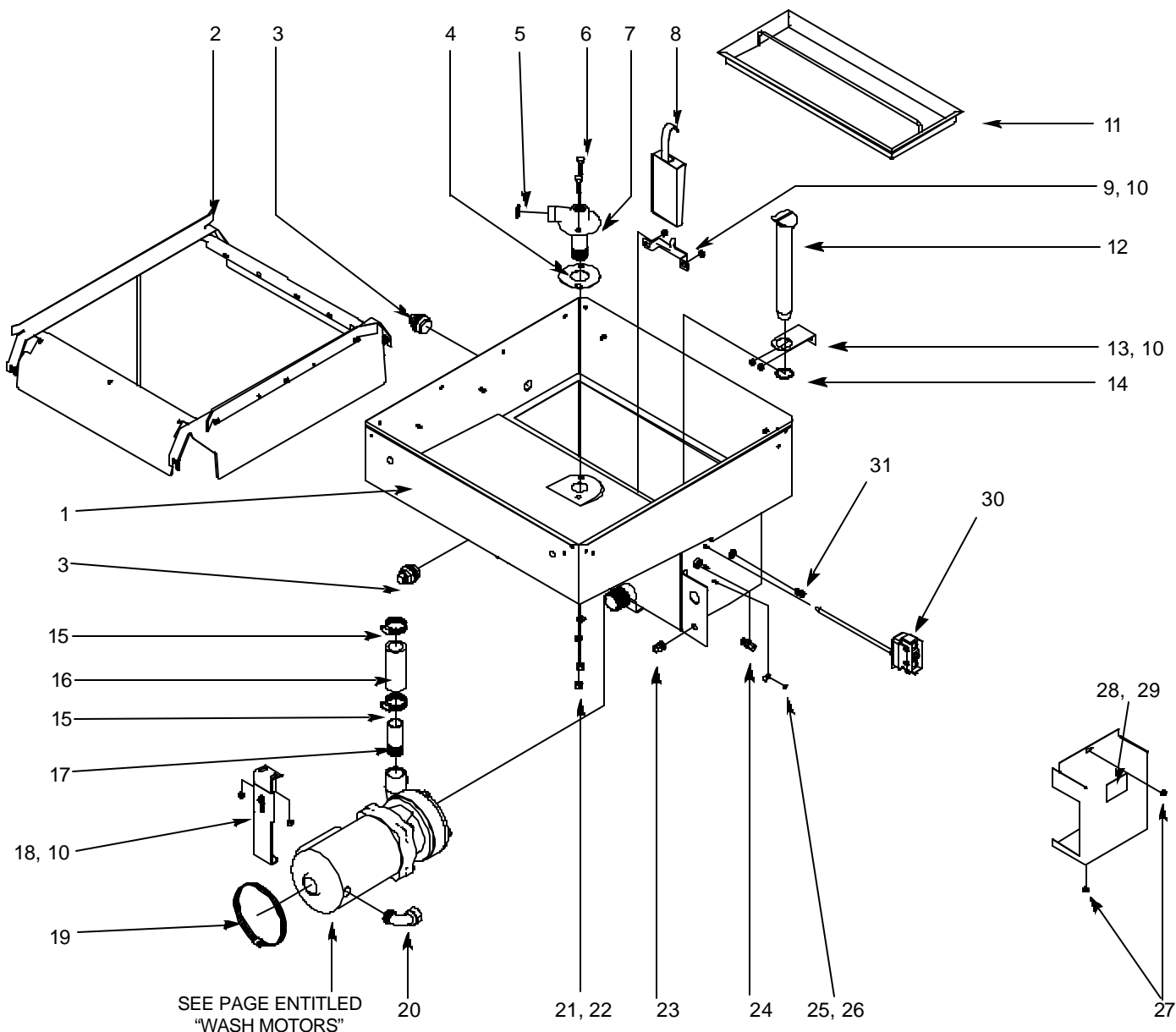

SEE PAGE ENTITLED  
"WASH MOTORS"

\* Represents an item not shown.

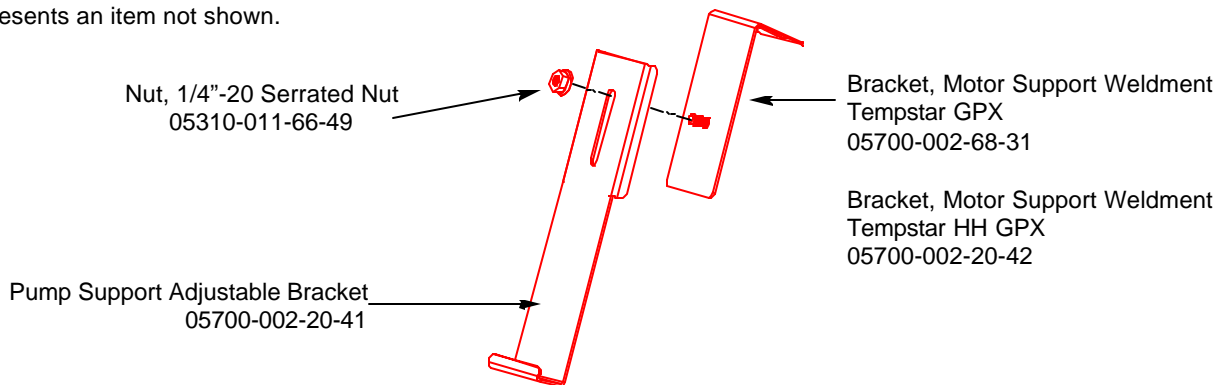

## SECTION 6: PARTS SECTION

### TUB ASSEMBLY (CONTINUED)

ITEM	QTY	DESCRIPTION	Mfg. No.
1	1	Tub Weldment, Tempstar GPX	05700-002-57-03
1	1	Tub Weldment, Tempstar HH GPX	05700-002-63-13
2	1	Rack Assembly	05700-002-01-00
3	2	Bulk Head Plug	04730-609-05-00
4	1	Gasket	05700-111-35-03
5	1	O-ring	05330-400-05-00
6	4	Bolt, Hex 3/8"-16 x 1 1/4" Long	05305-276-10-00
7	1	Lower Wash Manifold Weldment, Tempstar GPX	05700-031-46-00
7	1	Lower Wash Manifold Weldment, Tempstar HH GPX	05700-002-21-70
8	1	Suction Strainer Weldment, Tempstar GPX	05700-001-22-23
8	1	Suction Strainer Weldment, Tempstar HH GPX	05700-002-16-13
9	1	Suction Strainer Bracket, Tempstar GPX	05700-001-22-24
9	1	Suction Strainer Bracket, Tempstar HH GPX	05700-002-18-28
10	8	Locknut, 1/4"-20 with Nylon Insert	05310-374-02-00
11	1	Strainer Weldment	05700-021-50-07
12	1	Wash Overflow Weldment	05700-001-25-69
13	1	Overflow Support Bracket	05700-001-27-55
14	1	O-Ring	05330-400-05-00
15	2	Clamp, Hose 1 5/16" to 2 1/4"	04730-719-01-37
16	1	Discharge Hose	05700-011-88-24
17	1	Nipple	05700-021-34-84
18	1	Pump Support Bracket Assembly, Tempstar GPX	05700-002-00-46
18	1	Pump Support Bracket Assembly, Tempstar HH GPX	05700-002-22-73
19	1	Clamp, Hose 5 5/8" to 6"	04730-011-34-90
20	1	Connector, 1/2" 90°	05975-111-01-00
21	4	Nut, 3/8"-16 S/S Hex	05310-276-01-00
22	4	Lockwasher 3/8"	05311-276-01-00
23	1	Fitting, Olflex	05975-205-43-00
24	1	Union, 1/4"	05700-001-16-52
25	1	Clamp, 1/8" Nylon	05975-601-10-15
26	1	Locknut, 6-32 with Nylon Insert	05310-373-03-00
27	4	Locknut, 10-24 with Nylon Insert	05310-373-01-00
28	1	Cover, Wash	05700-031-47-57
29	1	Decal, Warning-Disconnect Power	09905-100-75-93
30	1	Kit, Thermostat Regulating, Tempstar GPX	06401-003-18-25
30	1	Kit, Thermostat Regulating, Tempstar HH GPX	06401-003-18-27
31	1	Fitting, 1/4" Imperial Brass	05310-924-02-05

The Tempstar models covered in this manual come supplied with various wash motor assemblies (a wash motor assembly includes the wash motor and the pump end), depending on the characteristics of the machine. To ensure that you order the correct wash motor assembly for the model you are servicing, please refer to the following table:

<u>Model</u>	<u>Volts</u>	<u>Hz</u>	<u>Phase</u>	<u>Wash Motor Assembly</u>
Tempstar GPX	208	60	1	06105-121-35-18
Tempstar GPX	230	60	1	06105-121-35-18
Tempstar HH GPX	208	60	1	06105-002-01-29
Tempstar HH GPX	230	60	1	06105-002-01-29

**Important note:** When servicing a wash motor, it is important to refer to the wiring schematic found on the motor, to ensure that the motor is wired correctly. Different manufacturers of motors may not use the same wire color codes and therefore, your new motor, which may have been built by someone different than who built your original motor, may not connect using the same wires. Always refer to the wiring diagrams on the motor you are installing. If the motor you are installing has had the schematic removed, contact Jackson MSC immediately for technical support.

**SECTION 6: PARTS SECTION**  
**CANTILEVER ARM/DOOR ASSEMBLIES TEMPSTAR GPX**

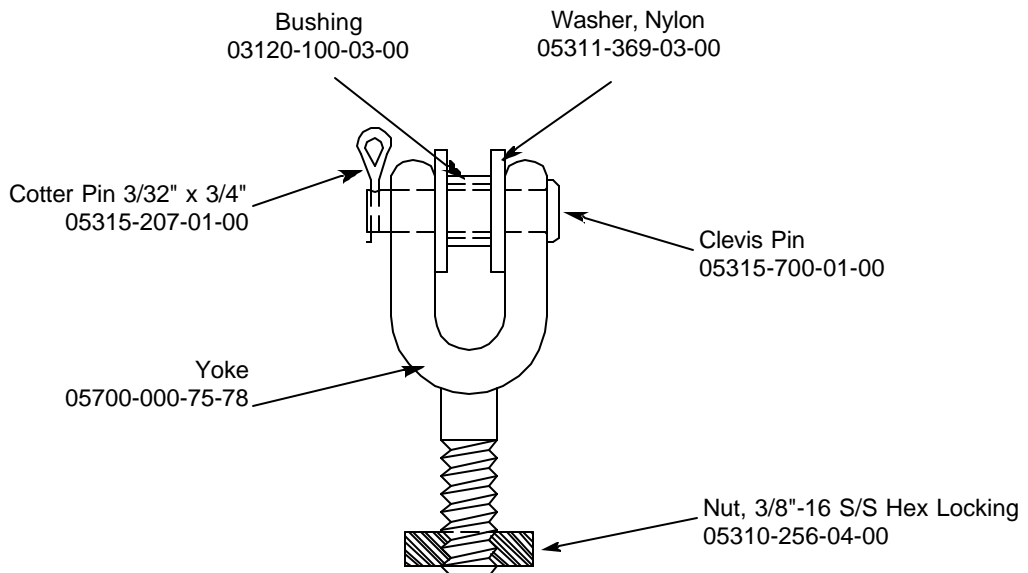
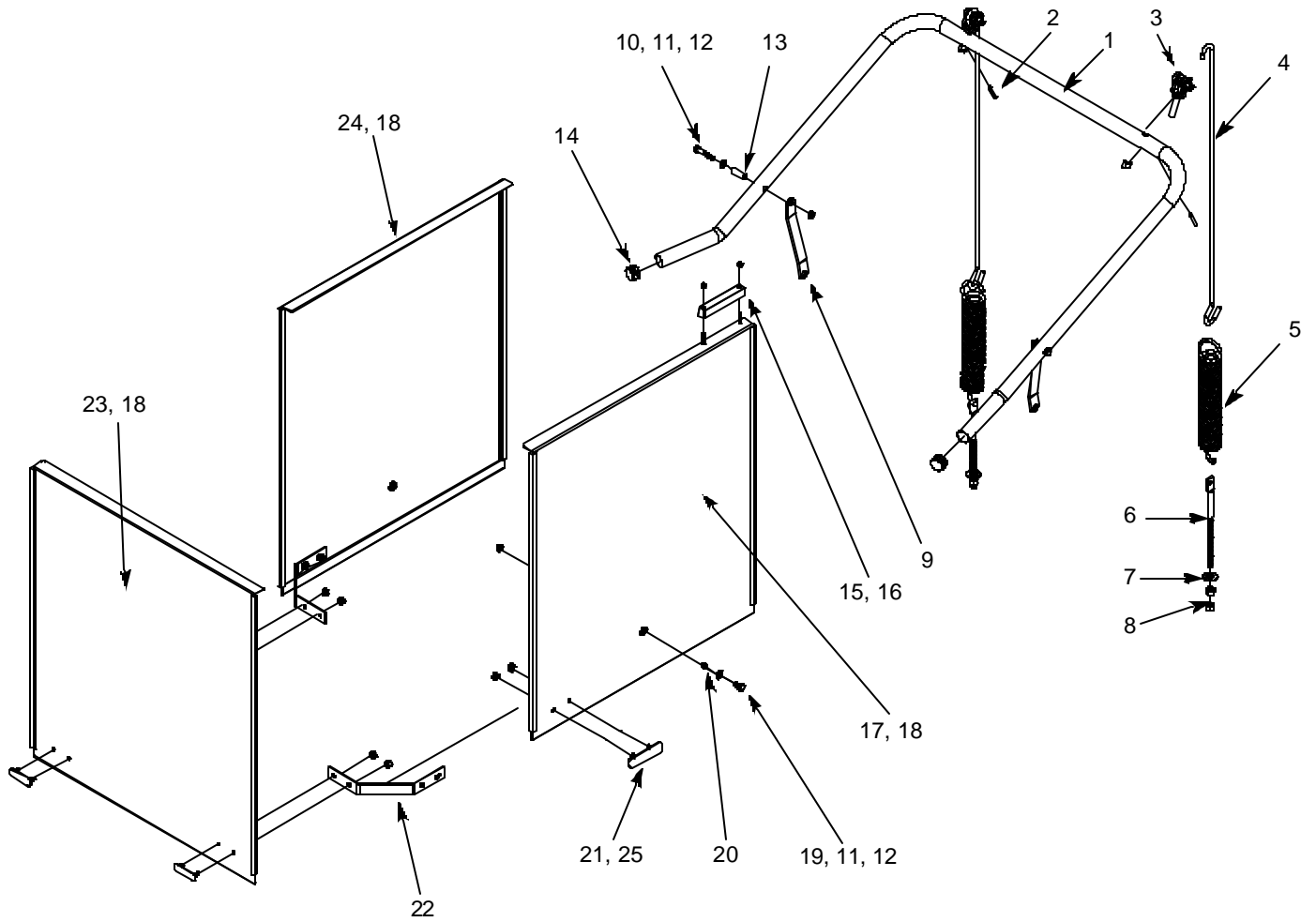

---

## SECTION 6: PARTS SECTION

### CANTILEVER ARM/DOOR ASSEMBLIES TEMPSTAR GPX (CONTINUED)

ITEM	QTY	DESCRIPTION	Mfg. No.
1	1	Cantilever Arm	05700-031-50-67
2	2	Spring Pin, 1/4" x 1 1/8"	05315-407-06-00
3	2	Yoke Assembly	05700-000-75-77
4	2	Rod, Spring	05700-002-29-38
5	2	Spring	05340-109-02-00
6	2	Bolt, Cantilever Hanger Eye 3/8"-16	05306-956-05-00
7	2	Washer, 3/8" ID x 7/8" OD S/S	05311-176-02-00
8	4	Nut, 3/8"-16 S/S Hex	05310-276-01-00
9	2	Connector, Cantilever Arm	05700-011-90-99
10	2	Screw 1/4"-20 x 1 1/2" Long S/S	05305-274-23-00
11	4	Washer, 1/4" S/S	05311-174-01-00
12	4	Locknut, 1/4"-20 S/S Hex with Nylon Insert Low Profile	05310-374-02-00
13	2	Sleeve, Cantilever Arm	05700-000-85-69
14	2	Plug, Cantilever Arm	05340-011-35-00
15	1	Magnet, Reed Switch	05930-111-51-68
16	2	Locknut, 8-32 S/S Hex with Nylon Insert	05310-272-02-00
17	1	Door, Right Side (Complete Assembly)	05700-002-30-88
17A	1	Right Door Weldment with Studs	05700-002-29-85
18	6	Door, Guides	05700-111-33-59
19	2	Screw, 1/4"-20 x 1/2" Long S/S	05305-274-02-00
20	2	Spacer, PB Bolt	05700-000-29-40
21	4	Door Plate	05700-002-20-78
22	2	Door Connector Bracket	05700-021-33-39
23	1	Door, Front (Complete Assembly)	05700-002-30-89
23A	1	Door Only, Front	05700-002-29-83
24	1	Door, Left Side (Complete Assembly)	05700-002-30-87
24A	1	Door Only, Left Side	05700-002-29-86
25	8	Locknut, 1/4"-20 with Nylon Insert	05310-374-02-00

**SECTION 6: PARTS SECTION**  
**CANTILEVER ARM/DOOR ASSEMBLIES TEMPSTAR HH GPX**

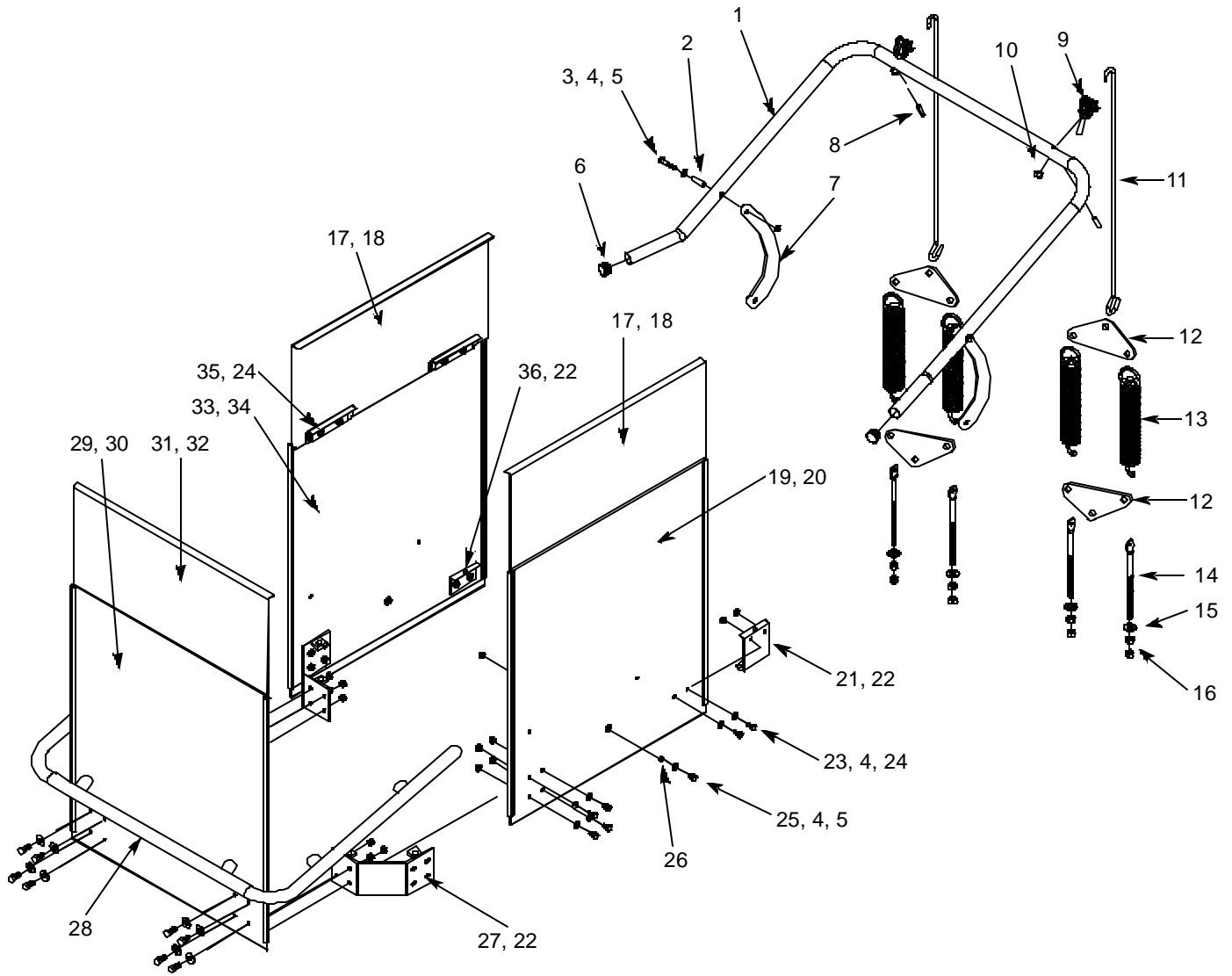

---

## SECTION 6: PARTS SECTION

### CANTILEVER ARM/DOOR ASSEMBLIES TEMPSTAR HH GPX (CONTINUED)

ITEM	QTY	DESCRIPTION	Mfg. No.
1	1	Cantilever Arm	05700-031-92-44
2	2	Sleeve, Cantilever Arm	05700-000-85-69
3	2	Screw, 1/4"-20 x 1 1/2" Long Hex Head	05305-274-23-00
4	4	Washer, 1/4" ID S/S	05311-174-01-00
5	4	Locknut, 1/4"-20 S/S Low Profile with Nylon Insert	05310-374-02-00
6	4	Plug, Cantilever	05340-011-35-00
7	2	Connecting Link	05700-021-92-45
8	2	Spring Pin, 1/4" Dia. x 1 1/8" Long	05315-407-06-00
9	2	Yoke Assembly	05700-000-75-77
10	2	Nut, 3/8"-16 S/S Hex Locking	05310-256-04-00
11	2	Rod, Spring Connecting	05700-002-00-91
12	4	Plate, Spring Multiplier	05700-002-00-88
13	4	Spring, Cantilever Door	05340-111-35-22
14	4	Bolt, Cantilever Hanger Eye 3/8"-16	05306-956-05-00
15	4	Washer, Impeller	05311-176-02-00
16	8	Nut, 3/8"-16 S/S Hex	05310-276-01-00
*	2	Door, Upper, Left and Right Assemblies	05700-002-01-30
17	2	Door, Upper, Left and Right Weldment	05700-002-29-59
18	4	Glide, Upper Door	05700-002-00-83
*	1	Door, Lower, Right Assembly	05700-002-01-33
19	1	Door, Lower, Right	05700-031-76-80
20	2	Glide, Lower Door	05700-002-23-64
21	1	Door Stop Magnet Assembly	05700-002-25-08
*	1	Door Stop Magnet Weldment	05700-002-01-27
*	1	Magnet	05930-111-69-25
*	2	End Cap	05700-011-60-92
22	6	Wear Button	05700-011-88-01
23	20	Screw, 1/4"-20 x 5/8"	05305-274-24-00
24	20	Locknut, 1/4"-20 S/S Hex with Nylon Insert	05310-374-01-00
25	2	Screw, 1/4"-20 x 1/2" Long Hex Head	05305-274-02-00
26	2	Spacer, PB Bolt	05700-000-29-40
27	2	Bracket, Door Connector	05700-001-99-39
28	1	Handle, Front Door Weldment	05700-002-00-90
*	1	Door, Lower, Front Assembly	05700-002-01-31
29	1	Door, Lower, Front	05700-031-76-77
30	2	Glide, Lower Door	05700-002-23-64
*	1	Door, Upper Front Assembly	05700-002-24-92
31	1	Door, Upper, Front Weldment	05700-002-29-57
32	2	Glide, Upper Door	05700-002-00-83
*	1	Door, Lower, Left Assembly	05700-002-01-32
33	1	Door, Lower, Left	05700-031-76-79
34	2	Glide, Lower Door	05700-002-23-64
35	6	Door Stop Weldment	05700-002-29-60
36	1	Door Stop	05700-002-00-84

## SECTION 6: PARTS SECTION

### INLET PLUMBING ASSEMBLIES

#### TEMPSTAR GPX

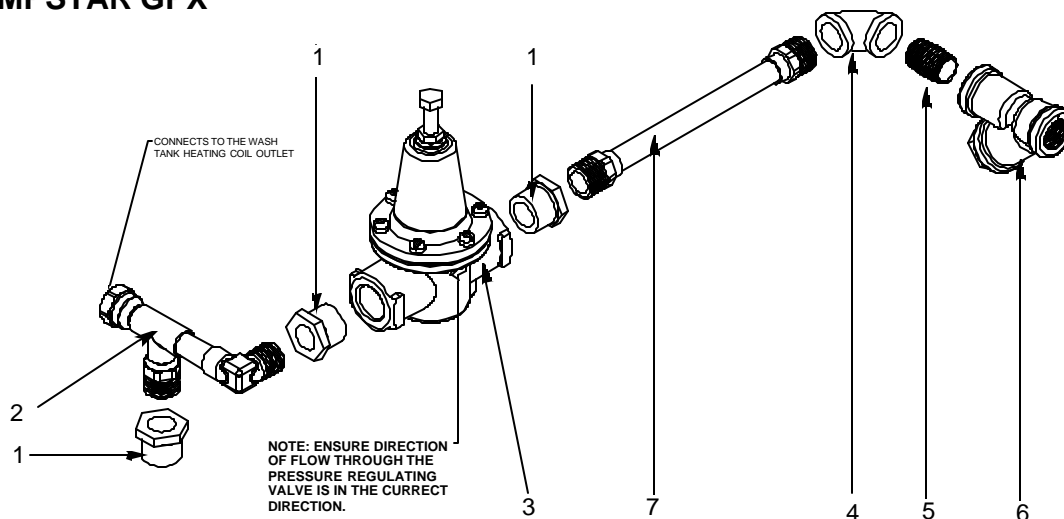

ITEM	QTY	DESCRIPTION	Mfg. No.
*	1	Plumbing, Inlet, Tempstar GPX	05700-002-56-69
1	3	Bushing, Hex 3/4" M to 1/2" F, Brass	04730-002-56-27
2	1	Outlet, Heating Coil Assembly	05700-002-56-70
3	1	Valve, Pressure Reducing, 3/4"	04820-002-51-53
4	1	Elbow, 90° 1/2" Street Brass	04730-206-08-00
5	1	Nipple, 1/2" Close Brass	04730-207-15-00
6	1	Y-Strainer, 1/2"	04730-217-01-10
7	1	Tubing, Inlet Plumbing Assembly	05700-002-56-71

#### TEMPSTAR HH GPX

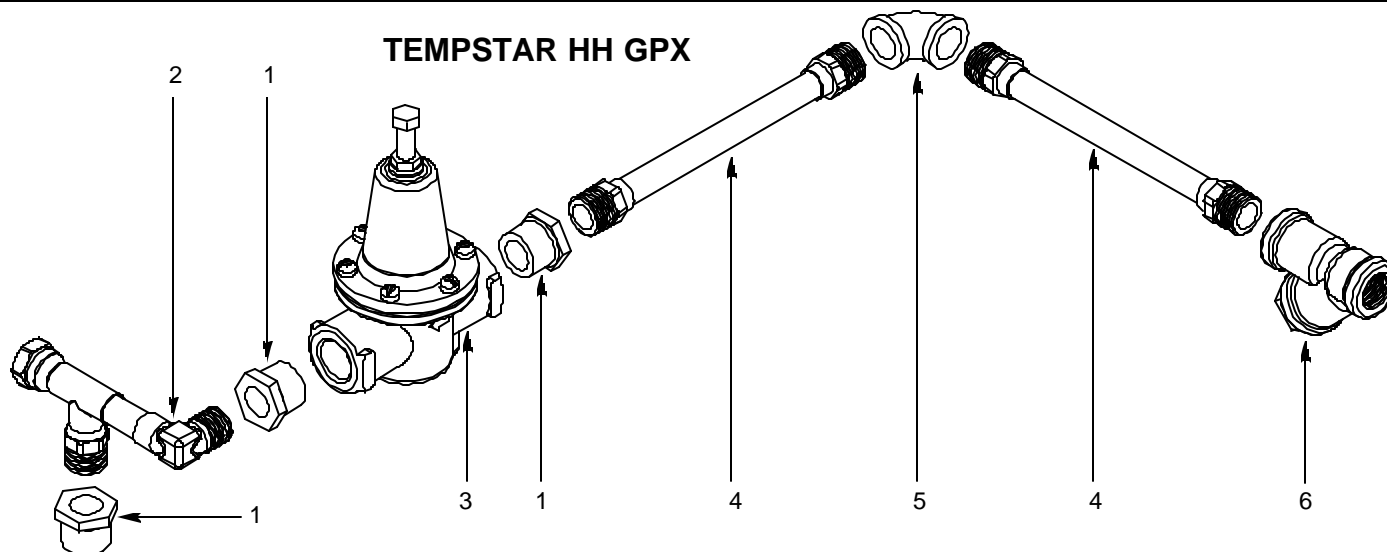

ITEM	QTY	DESCRIPTION	Mfg. No.
*	1	Plumbing, Inlet, Tempstar HH GPX	05700-002-63-16
1	3	Bushing, Hex 3/4" M to 1/2" F, Brass	04730-002-56-27
2	1	Outlet, Heating Coil Assembly	05700-002-56-70
3	1	Valve, Pressure Reducing, 3/4"	04820-002-51-53
4	2	Tubing, Inlet Plumbing Assembly	05700-002-56-71
5	1	Elbow, 90° 1/2"	04730-406-32-01
6	1	Y-Strainer, 1/2"	04730-217-01-10

**SECTION 6: PARTS SECTION**  
**RINSE HEADER PLUMBING ASSEMBLY**

Rinse Header Plumbing Assembly, Tempstar GPX  
 Rinse Header Plumbing Assembly, Tempstar HH GPX

05700-002-56-67  
 05700-002-58-02

Vacuum Breaker, 1/2"  
 04820-003-06-13

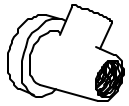

Rinse Tube Assembly, Tempstar GPX  
 05700-002-56-68

Rinse Tube Assembly, Tempstar HH GPX  
 05700-002-58-03



Ball Valve, 1/4"  
 04810-011-72-67



Pressure Gauge, 0-100 PSI  
 06685-111-88-34

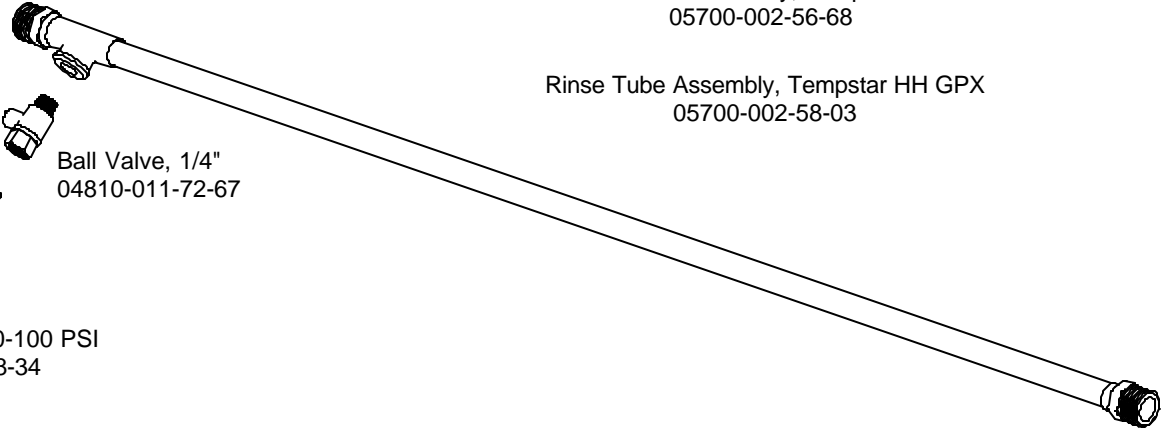

ITEM	QTY	DESCRIPTION	Mfg. No.
*	1	Rinse Hose Assembly	05700-002-57-05
	1	Hose, 1/2" x 27"	05700-002-57-04
	1	Fitting, 1/2"	04730-011-93-99

**SECTION 6: PARTS SECTION**  
**RECIRCULATING PLUMBING ASSEMBLY**

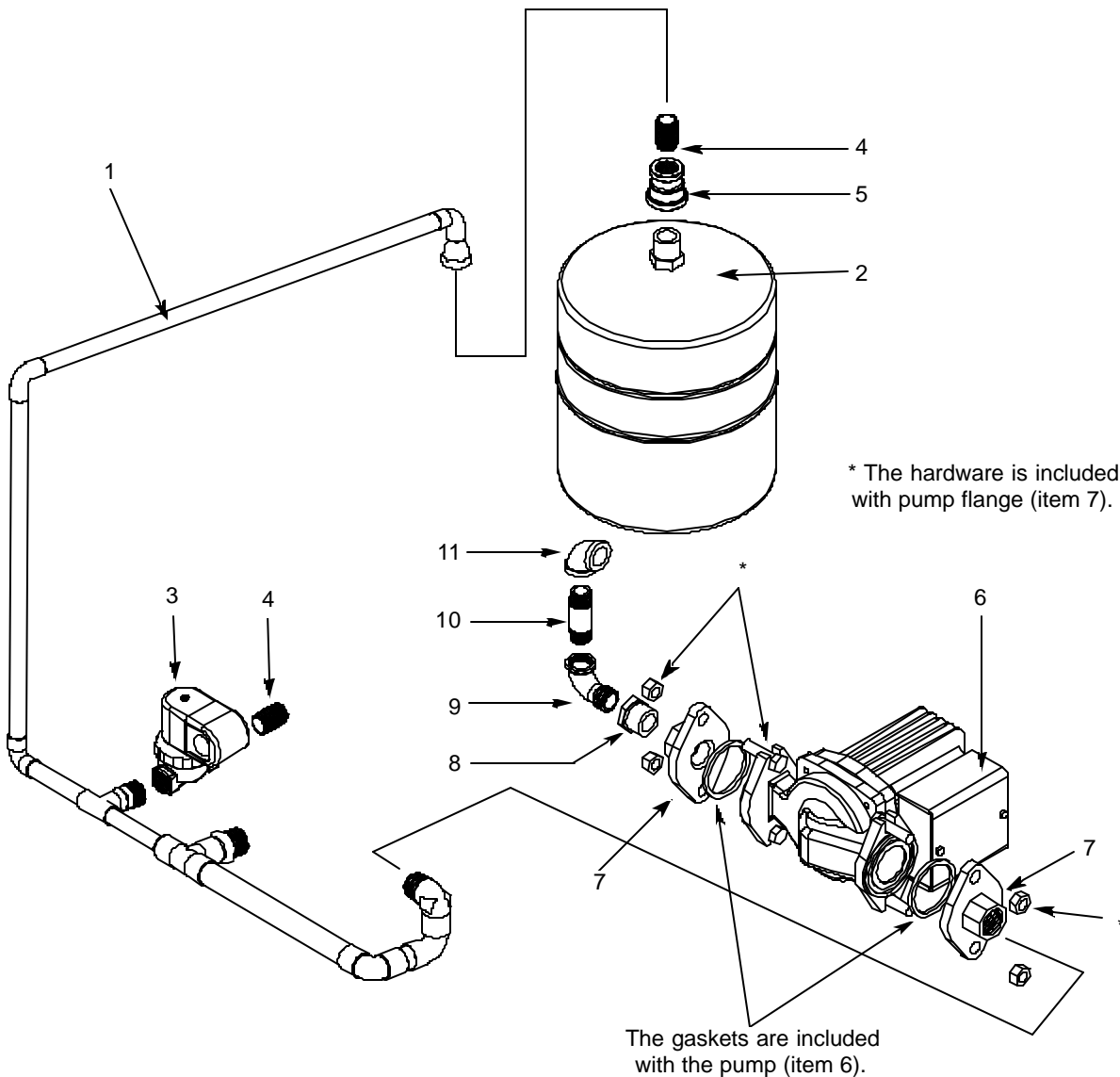

ITEM	QTY	DESCRIPTION	Mfg. No.
*	1	Plumbing, 110V Recirculating System Assembly	05700-002-56-64
*	1	Plumbing, 208-230V Recirculating System Assembly	05700-002-56-65
1	1	Tubing Assembly	05700-002-56-66
2	1	Tank, Thermal Expansion	05700-002-65-77
3	1	Valve, Solenoid 1/2" 110 Volt	04810-100-12-18
3	1	Valve, Solenoid 1/2" 208-230 Volt	04810-100-09-18
4	2	Nipple, 1/2" Close Brass	04730-207-15-00
5	1	Coupling, 1/2" x 3/4" Brass	04730-204-07-00
6	1	Pump, 110V Recirculating	06105-002-56-25
6	1	Pump, 208-230V Recirculating	06105-002-56-26
7	1	Pump, Flange	04320-002-38-17
8	1	Bushing, Hex 3/4" M to 1/2" F Brass	04730-002-56-27
9	1	Elbow, 90° 1/2" Street Brass	04730-206-08-00
10	1	Nipple, 1/2" x 2" Brass	04730-207-19-00
11	1	Elbow, 1/2" NPT, 90° Brass	04730-011-42-96

## SECTION 6: PARTS SECTION

### RINSE SOLENOID VALVE & VACUUM BREAKER REPAIR PARTS KITS

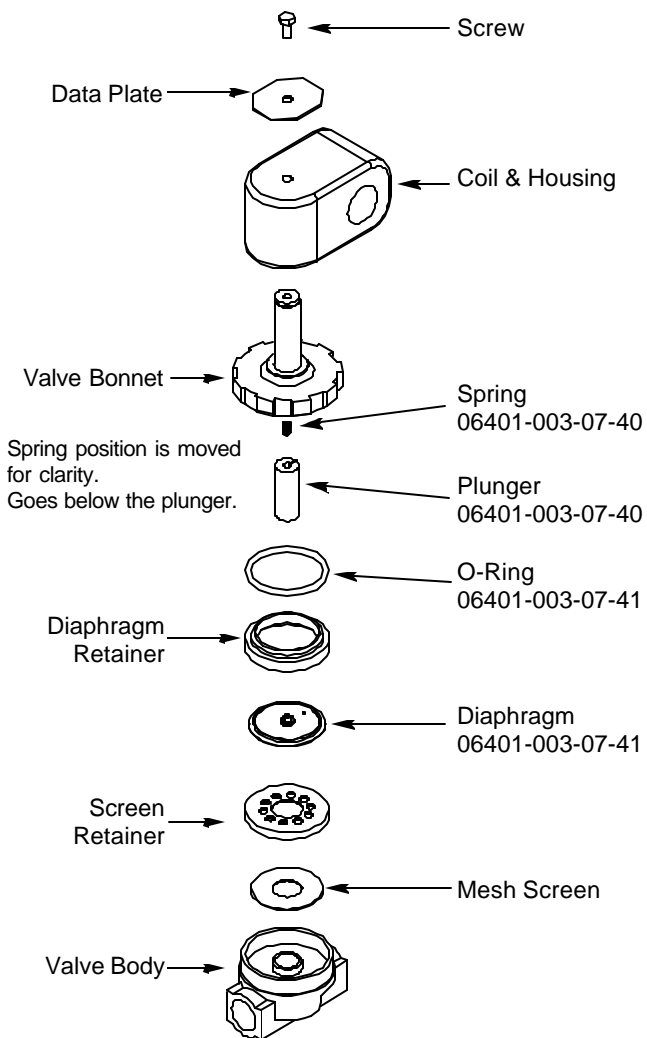

**Complete 110 Volt Solenoid Valve Assembly**

04810-100-12-18

**Coil & Housing only**

06401-003-07-43

**Complete 220 Volt Solenoid Valve Assembly**

04810-100-09-18

**Coil & Housing only**

06401-003-07-44

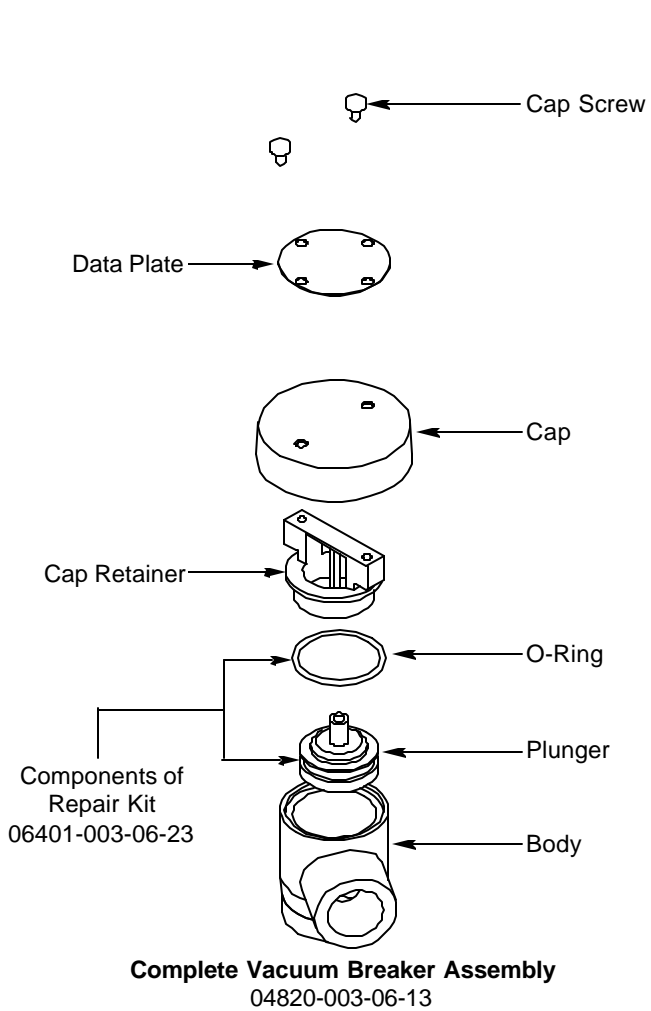

**Complete Vacuum Breaker Assembly**

04820-003-06-13

**SECTION 6: PARTS SECTION**  
**WASH & RINSE ARM/MANIFOLD ASSEMBLIES (TEMPSTAR GPX)**

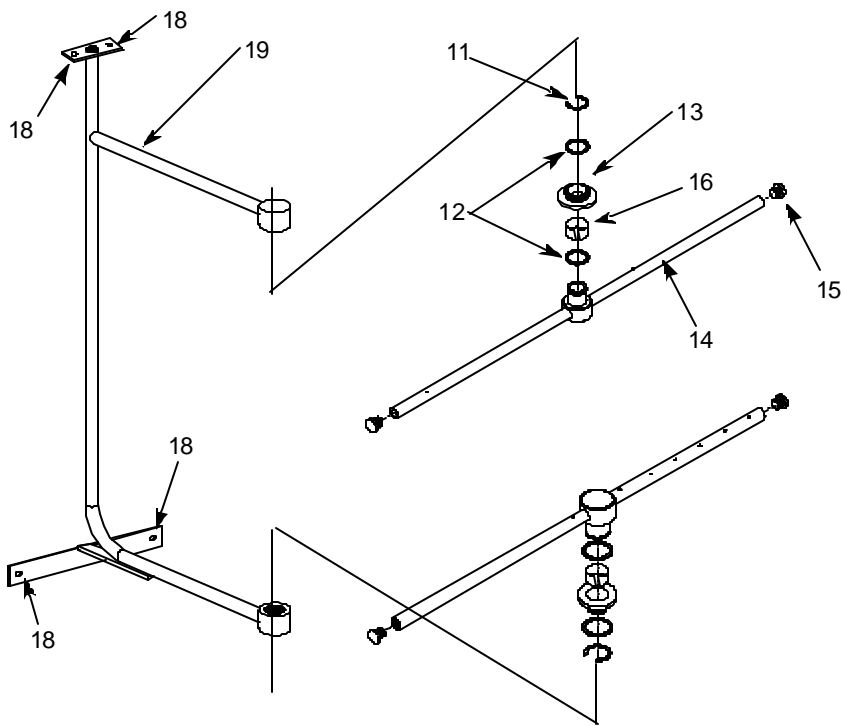

**DETAIL "A"**  
**FINAL RINSE ARMS & MANIFOLD**

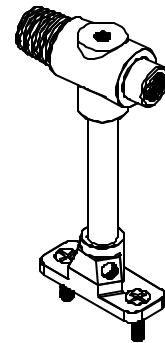

Rinse Injector Weldment  
 1 per machine  
 05700-002-56-75  
 Plug, 1/8" NPT, Brass  
 3 per Rinse Injector  
 04730-209-07-37

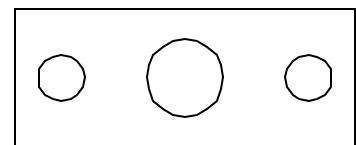

Rinse Injector Gasket  
 2 per machine  
 05330-111-42-81

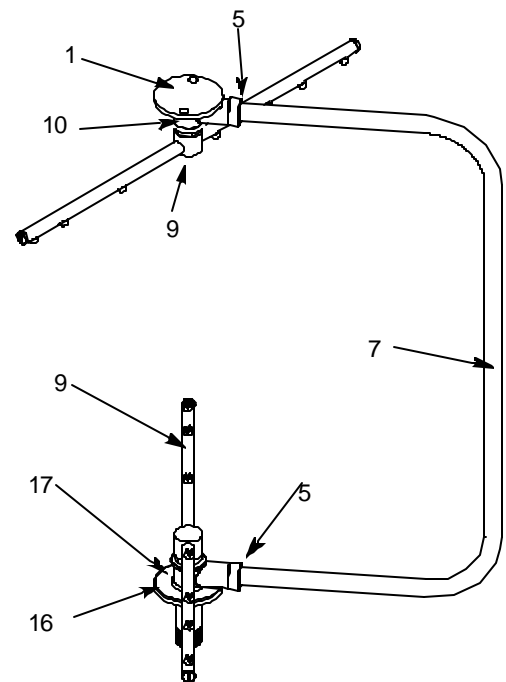
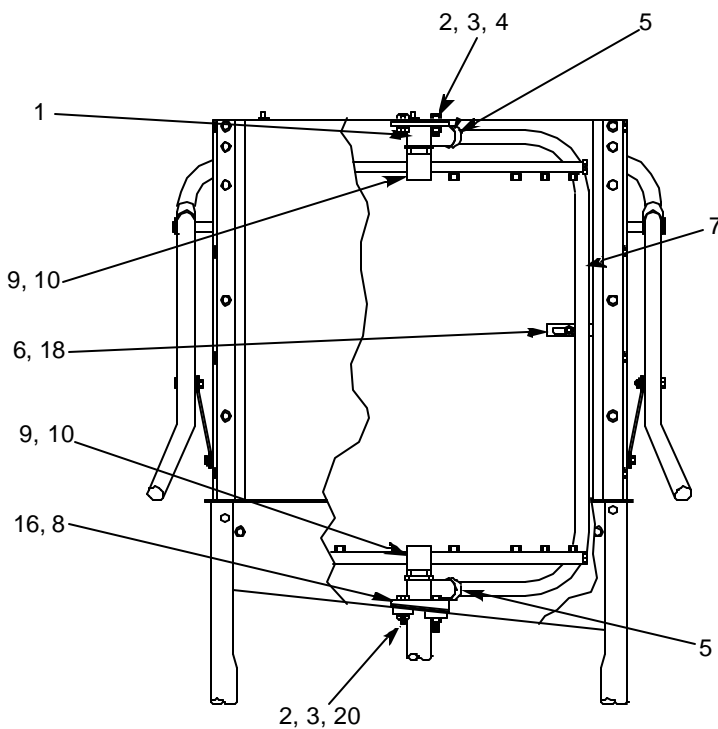

**DETAIL "B"**  
**WASH ARMS & MANIFOLD**

## SECTION 6: PARTS SECTION

### WASH & RINSE ARM/MANIFOLD ASSEMBLIES (TEMPSTAR GPX) (CONTINUED)

ITEM	QTY	DESCRIPTION	Mfg. No.
1	1	Upper Manifold	05700-031-34-82
2	4	Nut, 3/8"-16 S/S Hex	05310-276-01-00
3	4	Lockwasher, 3/8	05311-276-01-00
4	2	Bolt, Hex 3/8"-16 x 7/8" Long	05306-011-36-95
5	2	O Ring	05330-111-35-15
6	1	Positioning Bracket, Manifold Tube	05700-011-34-63
7	1	Tube, Wash Manifold	05700-031-92-58
8	2	Gasket, Manifold	05700-111-35-03
*	1	Wash Arm Assembly	05700-021-35-39
9	1	Wash Arm Weldment	05700-021-35-93
9a	1	Hub Nut	05700-011-35-94
9b	1	Hub Bushing	05700-011-35-96
9c	1	Hub Spindle	05700-011-35-95
9d	1	Ring, Retainer	05340-011-37-81
9e	15	3/16" Stainless Steel Ball	03120-100-02-00
9f	20	1/8" Stainless Steel Ball	03120-011-37-82
10	1	Bearing Assembly	05700-021-35-97
*	1	O-ring	05330-002-60-69
*	2	Rinse Arm Assembly	05700-002-58-09
11	2	Clip, Retaining, Rinse Head Bushing	05340-112-01-11
12	4	Washer	05330-011-42-10
13	2	Bushing, Rinse Head	05700-021-33-84
14	2	Rinse Arm	05700-031-49-58
15	4	Plug	04730-609-04-00
16	2	Bearing	03120-002-72-24
17	1	Lower Wash Manifold Weldment	05700-002-21-70
18	5	Locknut, 1/4"-20 S/S Hex with Nylon Insert	05310-374-01-00
19	1	Rinse Manifold Weldment	05700-002-01-19
20	2	Bolt, Hex 3/8"-16 x 1 1/4" Long	05305-276-10-00
21	1	Wash Arm, Double Assembly	05700-031-92-49

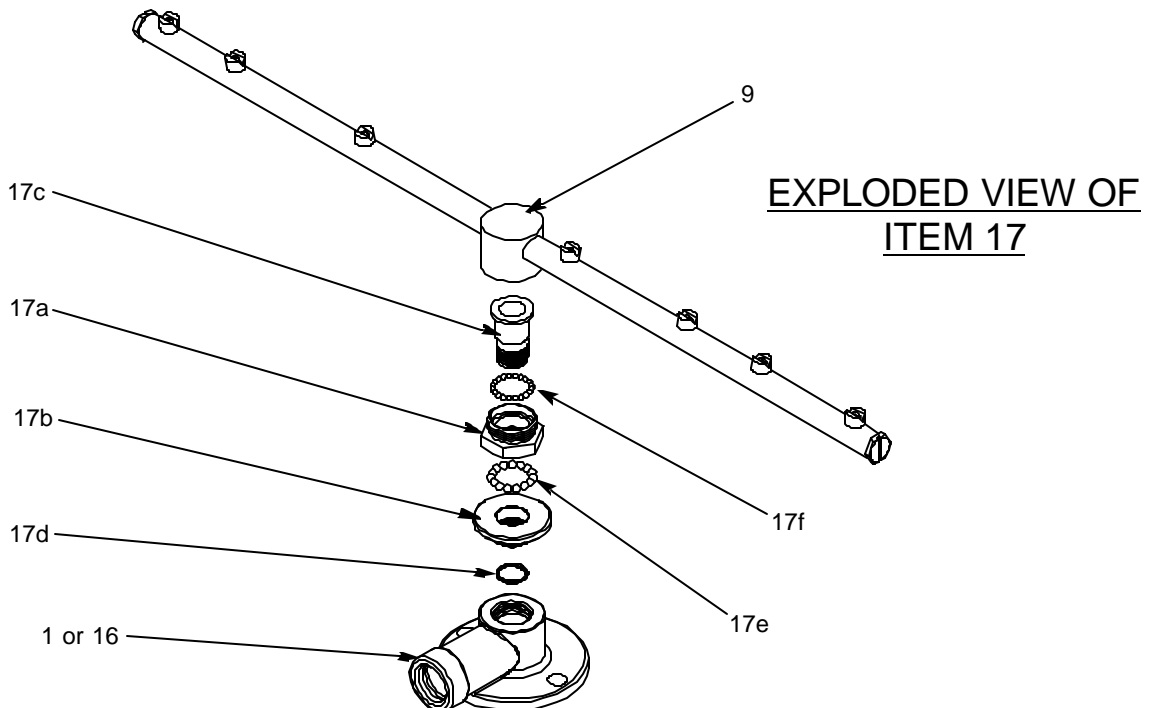

## SECTION 6: PARTS SECTION

### WASH & RINSE ARM/MANIFOLD ASSEMBLIES (TEMPSTAR HH GPX)

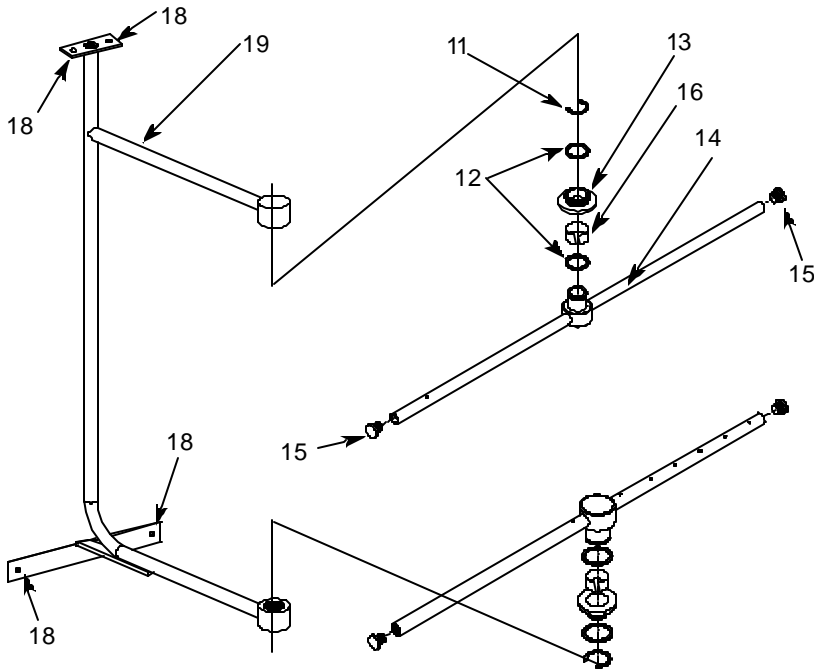

**DETAIL "A"**  
FINAL RINSE ARMS & MANIFOLD

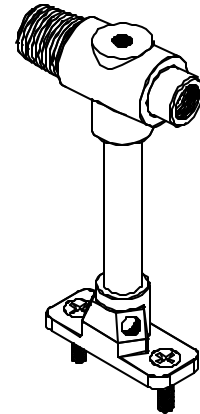

Rinse Injector Weldment  
1 per machine  
05700-002-56-75

Plug, 1/8" NPT, Brass  
3 per Rinse Injector  
04730-209-07-37

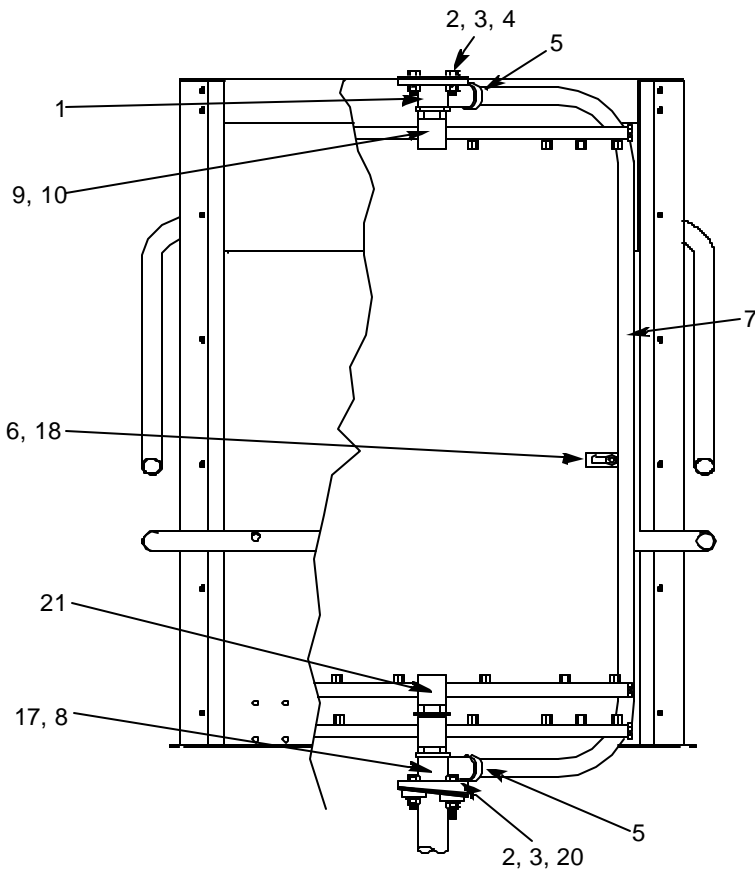

**DETAIL "B"**  
WASH ARMS & MANIFOLD

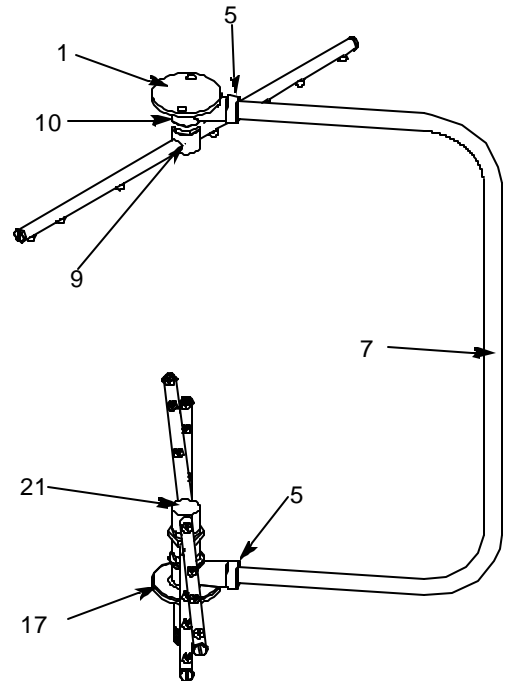

---

## SECTION 6: PARTS SECTION

### WASH & RINSE ARM/MANIFOLD ASSEMBLIES (TEMPSTAR HH GPX) (CONTINUED)

ITEM	QTY	DESCRIPTION	Mfg. No.
1	1	Upper Manifold	05700-031-34-82
2	4	Nut, 3/8"-16 S/S Hex	05310-276-01-00
3	4	Lockwasher, 3/8	05311-276-01-00
4	2	Bolt, Hex 3/8"-16 x 7/8" Long	05306-011-36-95
5	2	O Ring	05330-111-35-15
6	1	Positioning Bracket, Manifold Tube	05700-011-34-63
7	1	Tube, Wash Manifold	05700-031-92-58
8	2	Gasket, Manifold	05700-111-35-03
*	1	Wash Arm Assembly	05700-021-35-39
9	1	Wash Arm Weldment	05700-021-35-93
10	1	Bearing Assembly	05700-021-35-97
*	1	O-ring	05330-002-60-69
*	2	Rinse Arm Assembly	05700-002-58-09
11	2	Clip, Retaining, Rinse Head Bushing	05340-112-01-11
12	4	Washer	05330-011-42-10
13	2	Bushing, Rinse Head	05700-021-33-84
14	2	Rinse Arm	05700-031-49-58
15	4	Plug	04730-609-04-00
16	2	Bearing	03120-002-72-24
17	1	Lower Wash Manifold Weldment	05700-002-21-70
18	5	Locknut, 1/4"-20 S/S Hex with Nylon Insert	05310-374-01-00
19	1	Rinse Manifold Weldment	05700-002-01-19
20	2	Bolt, Hex 3/8"-16 x 1 1/4" Long	05305-276-10-00
21	1	Wash Arm, Double Assembly	05700-031-92-49

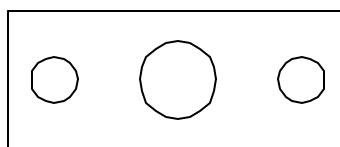

Rinse Injector Gasket  
2 per machine  
05330-111-42-81

# SECTION 6: PARTS SECTION

## COIL ASSEMBLY

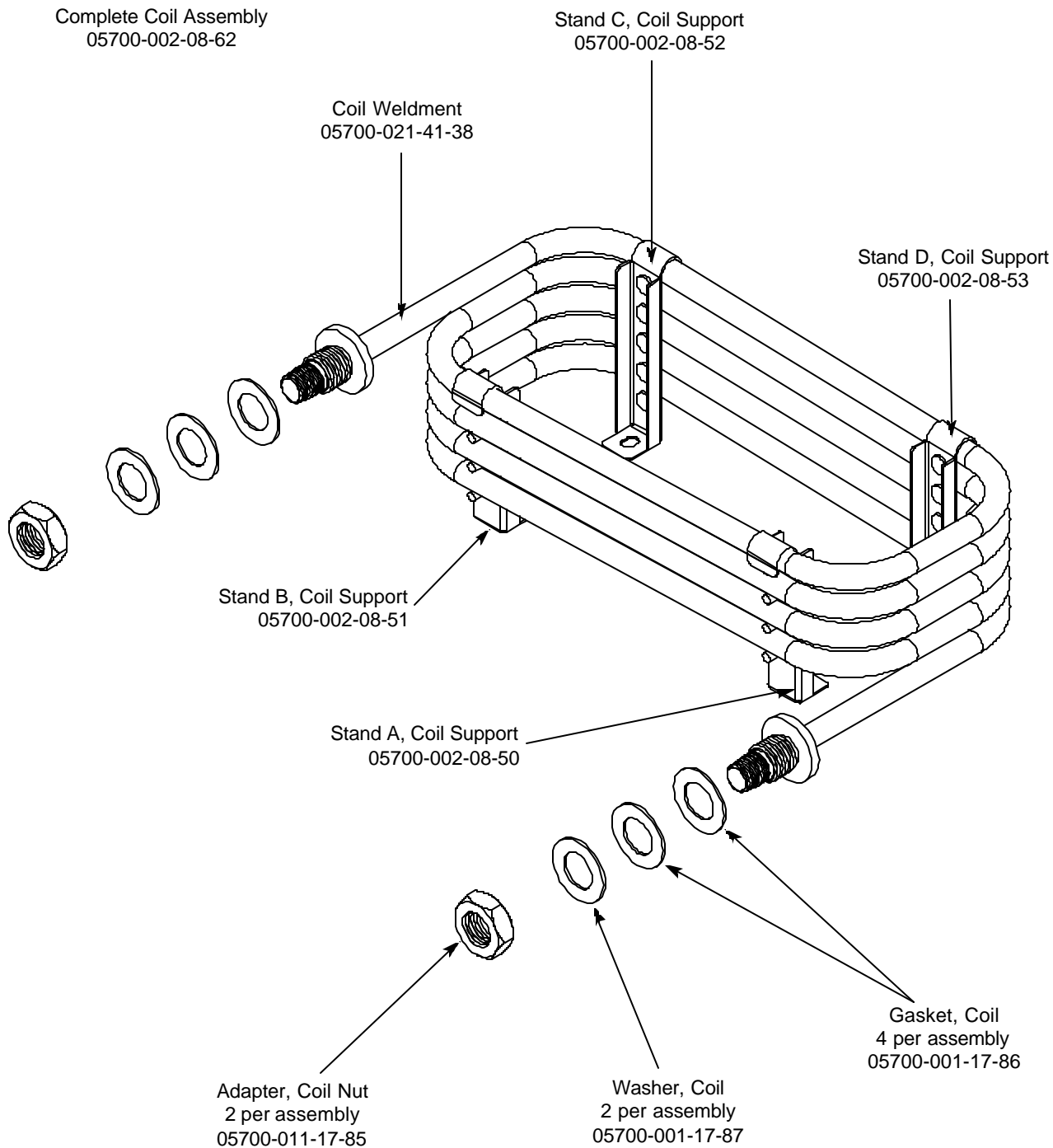

## SECTION 6: PARTS SECTION

### EXHAUST FAN CONTROL OPTION/SAFETY DOOR INTERLOCK (SDI) OPTION

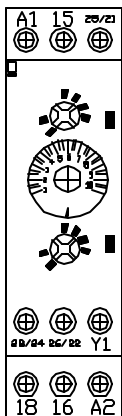

Exhaust Fan Control  
Delay Timer  
05945-011-65-44

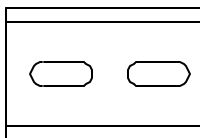

Exhaust Fan Control  
2" Din Rail  
05700-002-36-09

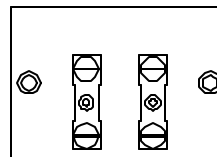

Exhaust Fan Control  
Terminal Board  
05940-011-84-41

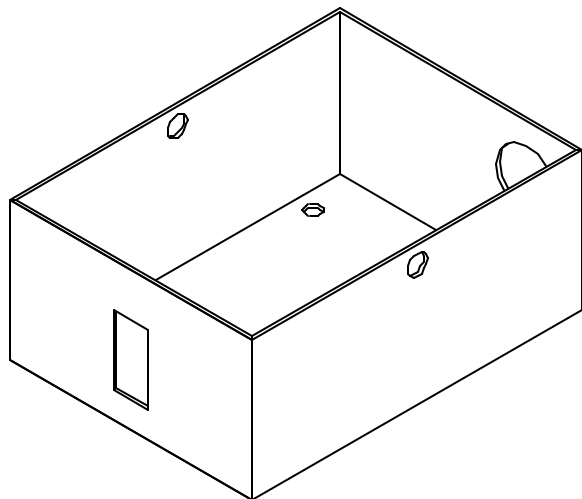

Safety Door Interlock Box Bottom  
05700-001-21-26

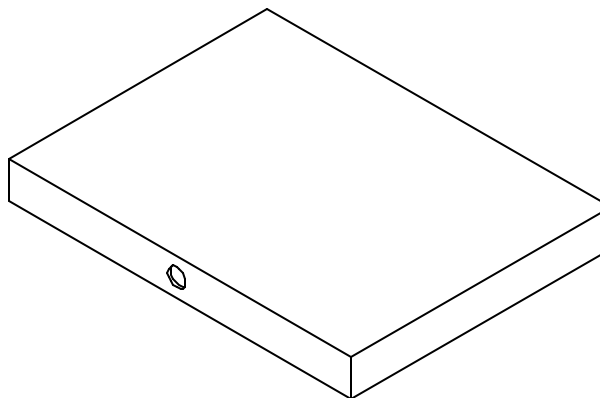

Safety Door Interlock Box Cover  
05700-001-21-27

Other Safety Door Interlock (SDI) components (not shown):

Pipe Clamp (found on the side of the machine)  
Solenoid, Electrical Interlock Option  
Relay

05700-000-35-05  
04810-100-61-33  
05945-111-47-51

**SECTION 6: PARTS SECTION**  
**TEMPSTAR GPX FALSE PANEL INSTALLATION**

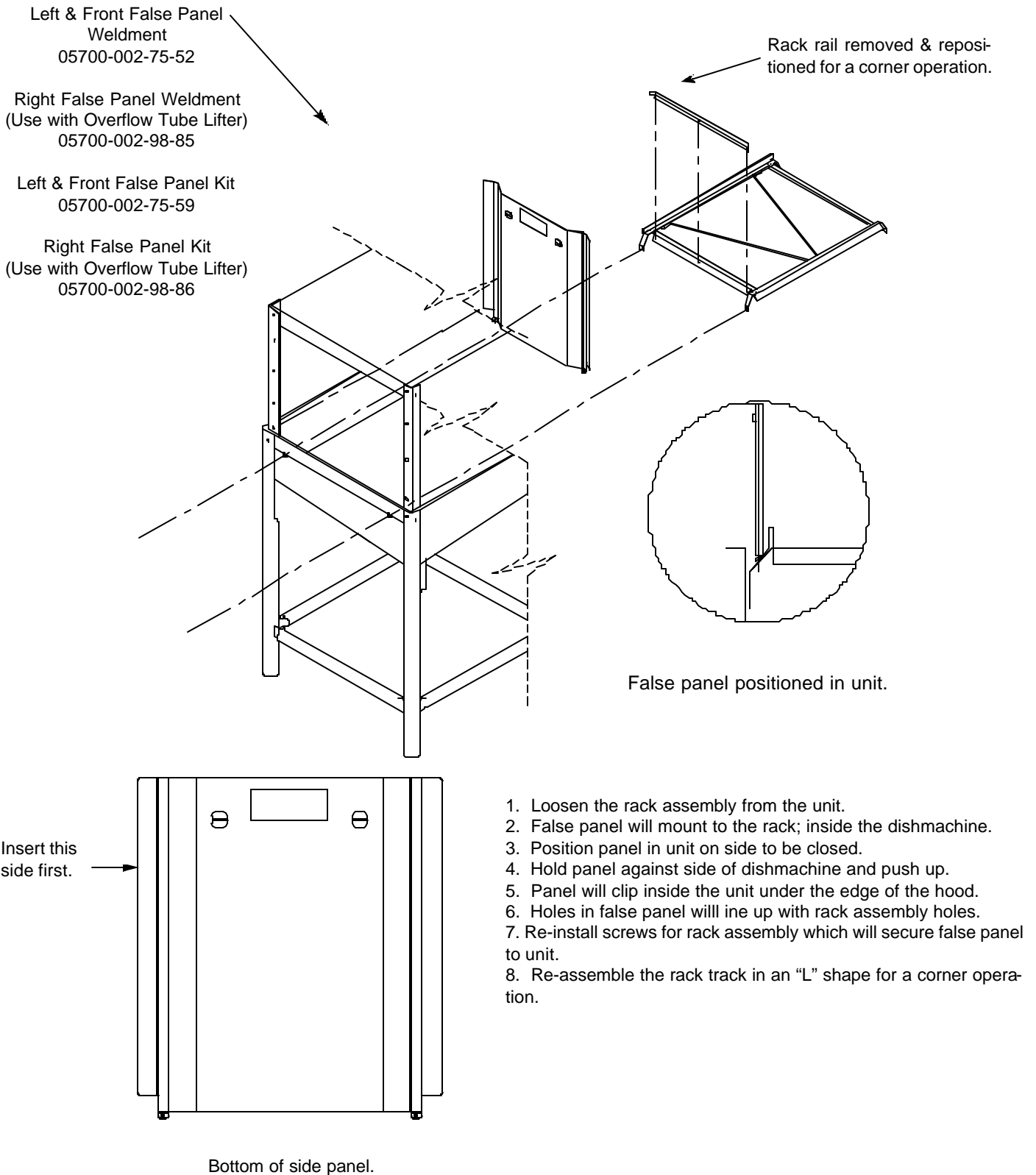

1. Loosen the rack assembly from the unit.
2. False panel will mount to the rack; inside the dishmachine.
3. Position panel in unit on side to be closed.
4. Hold panel against side of dishmachine and push up.
5. Panel will clip inside the unit under the edge of the hood.
6. Holes in false panel will line up with rack assembly holes.
7. Re-install screws for rack assembly which will secure false panel to unit.
8. Re-assemble the rack track in an "L" shape for a corner operation.

**SECTION 6: PARTS SECTION**  
**TEMPSTAR HH GPX FALSE PANEL INSTALLATION**

False Panel  
 05700-002-52-54

Kit, False Panel with  
 Mounting Hardware  
 05700-002-52-89

Rack rail removed and repositioned for a corner operation.

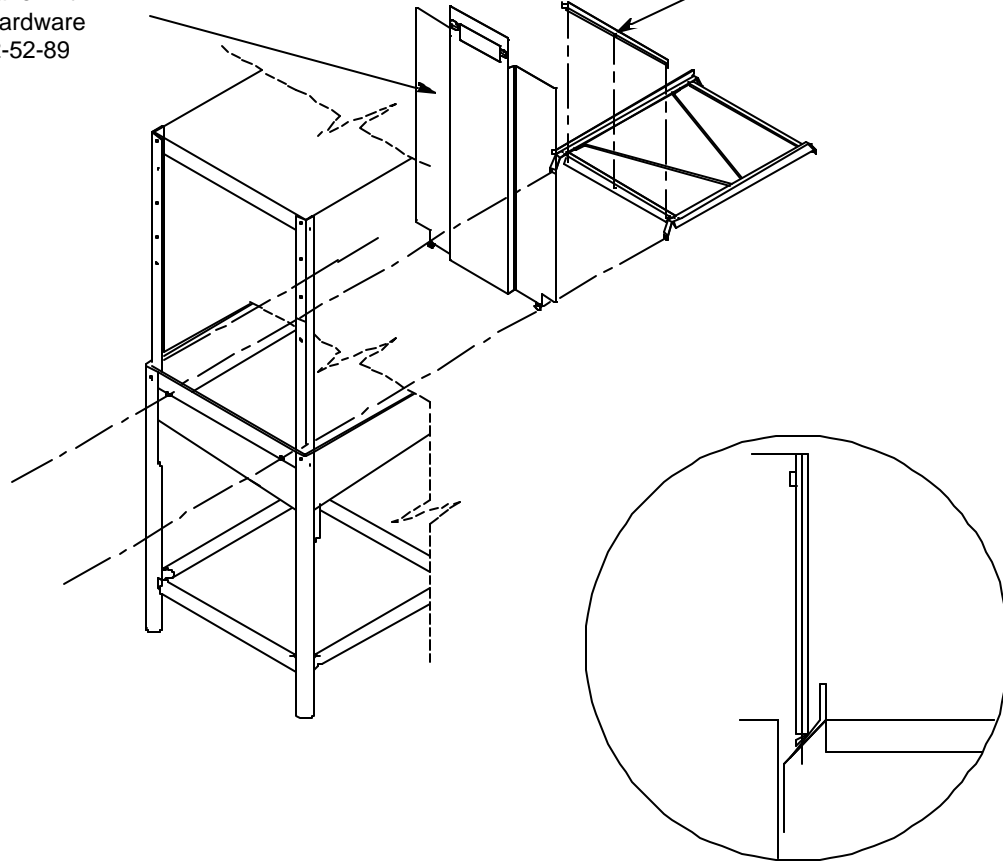

False Panel Positioned in unit.

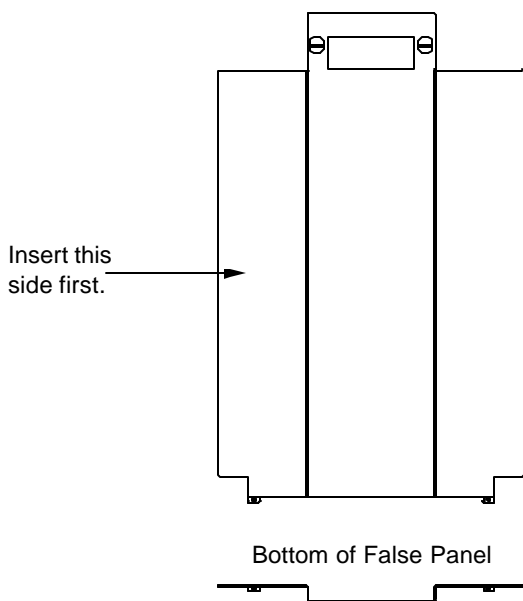

1. Remove the rack assembly from the dishmachine.
2. The false panel will mount inside of the dishmachine.
3. Position the panel in the dishmachine on the side to be closed.
4. Hold the panel against the side of the dishmachine and push upward.
5. The panel will clip in at the top, inside of the unit.
6. The holes in the false panel will line up with the rack assembly holes.
7. Re-install the screws for the rack assembly which will secure the false panel to the unit.
8. Re-assemble the rack track in an "L" shape for a corner operation.

## SECTION 6: PARTS SECTION

### DRAIN QUENCH ASSEMBLY

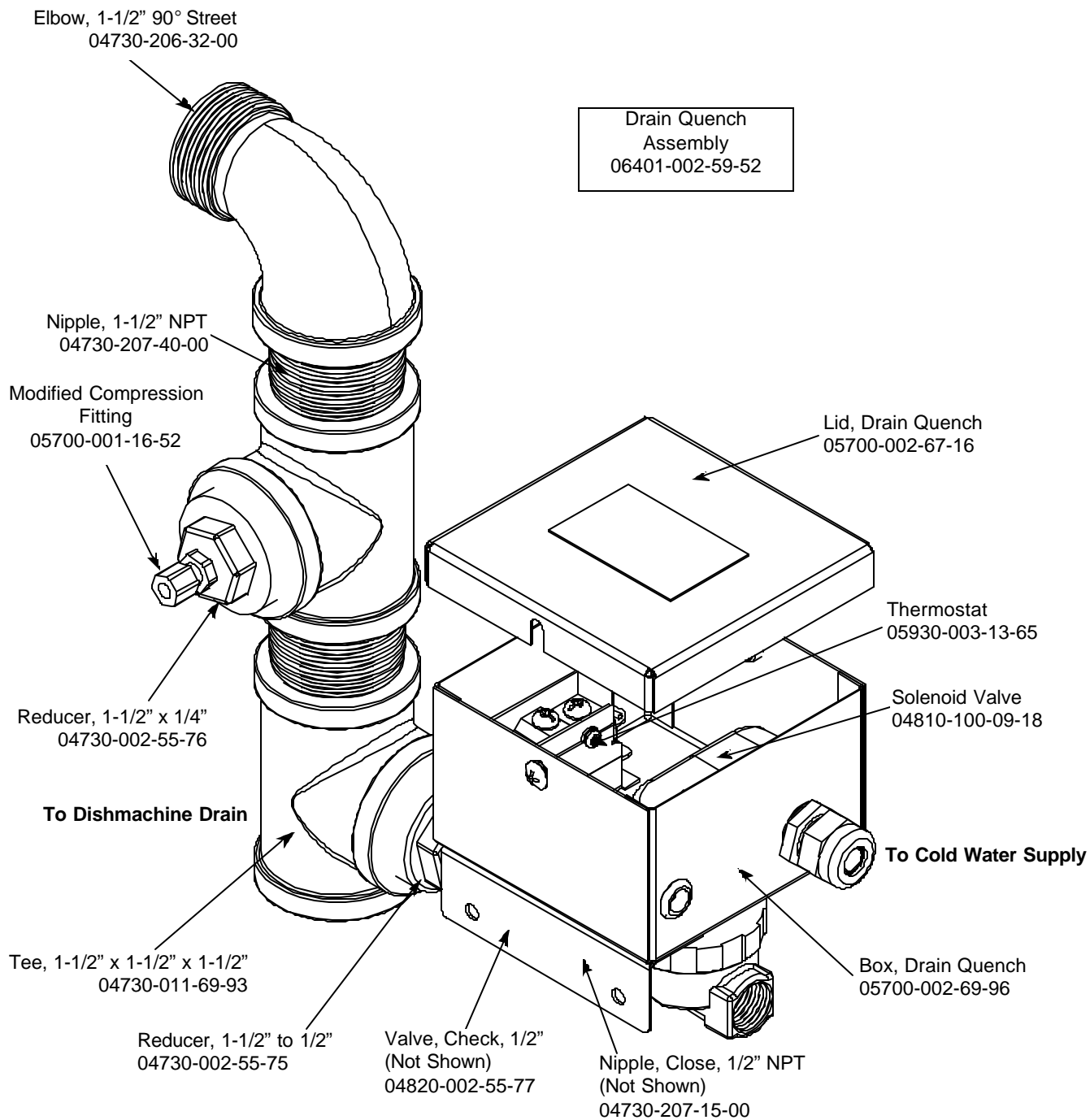

From the existing drain, attach the two additional Tees using the 1-1/2" NPT Close Nipples. Tighten the Reducers into the Tees as shown above. Attach the Modified Compression Fitting into the 1-1/2" to 1/4" Reducer. Position the bulb of the thermostat so that it rests approximately 1/4" from the bottom of the Tee. Tighten the Modified Compression Fitting as required. Attach to the incoming cold water line. Use pipe dope or thread tape as required to prevent any leaks.

---

# **SECTION 7: ELECTRICAL SCHEMATICS**

# SECTION 7: ELECTRICAL SCHEMATICS

## TEMPSTAR GPX 115 VOLT - 50/60 HERTZ - SINGLE PHASE

### LEGEND

- L1 N POWER DISTRIBUTION BLOCK
- GND GROUND
- M1 WASH PUMP MOTOR
- P1 CIRCULATOR PUMP
- R1 CONTROL RELAY
- R2 WASH MOTOR CONTACTOR
- R3 WASH TEMPERATURE RELAY
- R4 CIRCULATOR PUMP RELAY
- TM TIMER MOTOR
- C1 CYCLE SWITCH
- C2 AUTO START RESET SWITCH
- C3 WASH CYCLE SWITCH
- C4 RINSE/FILL SWITCH
- S1 POWER SWITCH
- S2 DOOR SWITCH
- S3 NORMAL/DELIME SWITCH
- E1 POWER LIGHT
- E2 CYCLE LIGHT
- FS FILL SOLENOID
- TS WASH THERMOSTAT SWITCH
- WL WATER LEVEL CONTROL
- HP HIGH LEVEL PROBE
- CF CONSTANT VOLTAGE CONNECTION
- SF SWITCHED VOLTAGE CONNECTION
- RF RINSE AID CONNECTION
- DF DETERGENT CONNECTION

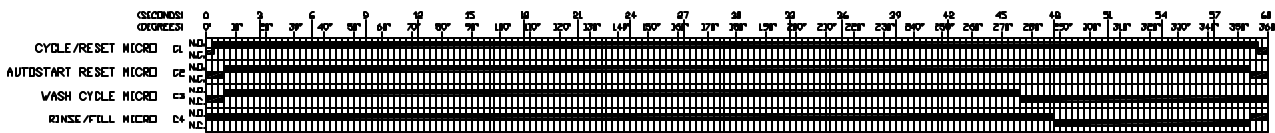
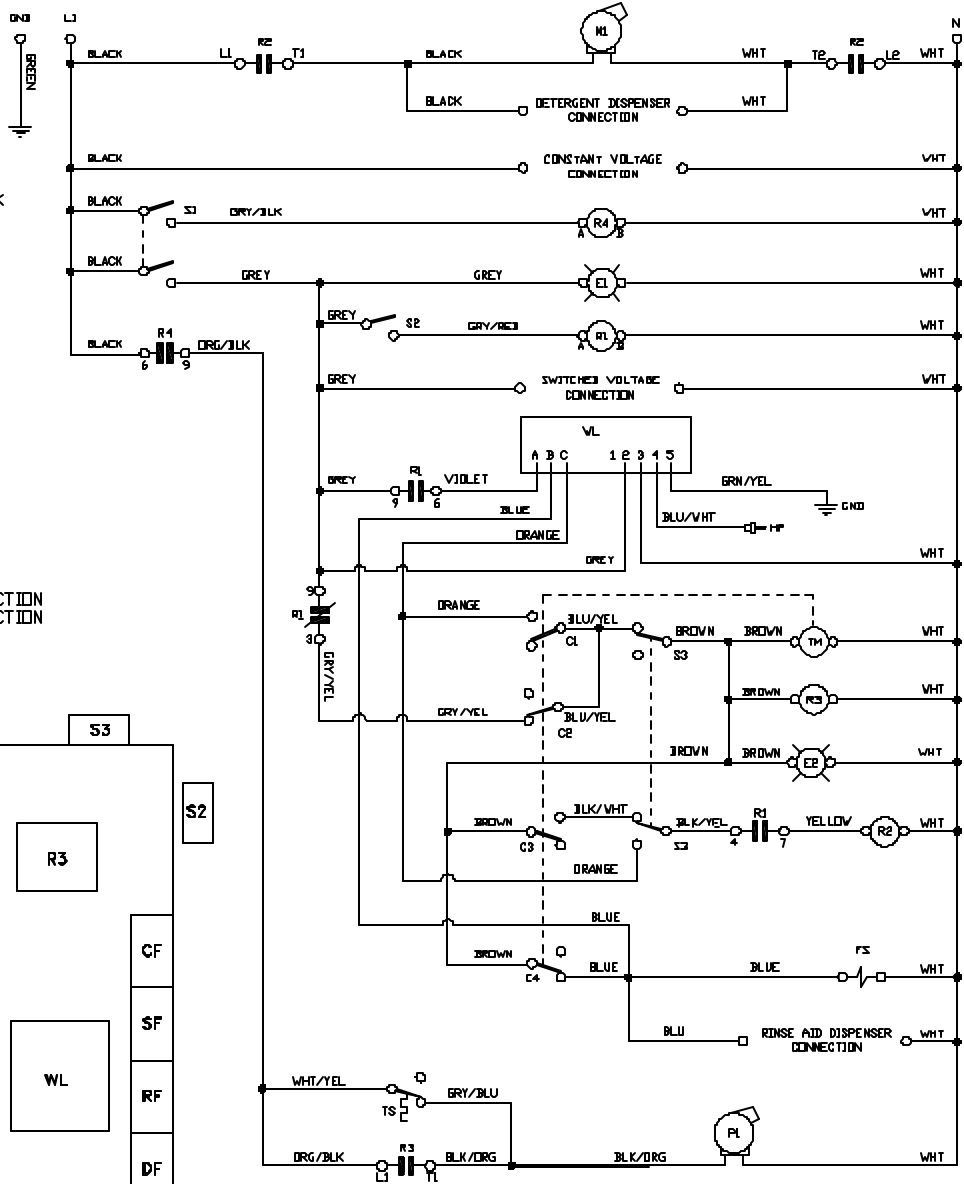
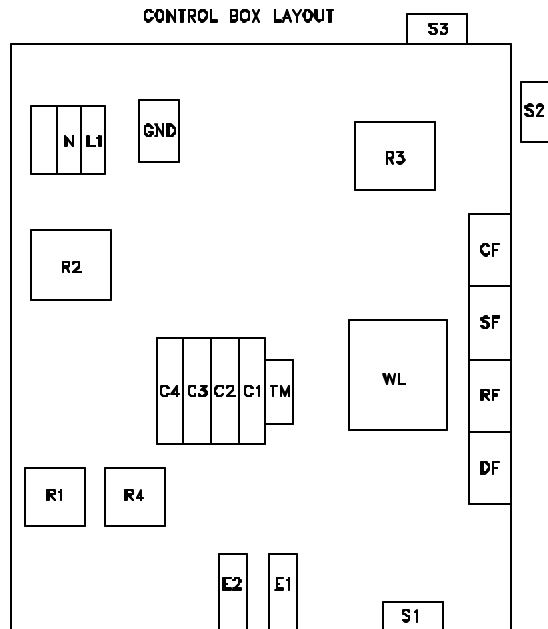

9903-002-56-091a



# SECTION 7: ELECTRICAL SCHEMATICS

## TEMPSTAR HH GPX 115 VOLT - 50/60 HERTZ - SINGLE PHASE

### LEGEND

L1 N	POWER DISTRIBUTION BLOCK
GND	CHASSIS GROUND
M1	WASH PUMP MOTOR
P1	CIRCULATOR PUMP
R1	CONTROL RELAY
R2	WASH MOTOR CONTACTOR
R3	WASH TEMPERATURE RELAY
S1	POWER SWITCH
S2	DOOR SWITCH
S3	NORMAL/DELIME SWITCH
S4	CYCLE SELECTOR SWITCH 1
S5	CYCLE SELECTOR SWITCH 2
S6	CYCLE SELECTOR SWITCH 3
S7	CYCLE SELECTOR SWITCH 4
C1	CYCLE SWITCH
C2	AUTO START RESET SWITCH
C3	WASH CYCLE SWITCH
C4	RINSE/FILL SWITCH
E1	POWER LIGHT
E2	CYCLE LIGHT
FS	FILL SOLENOID
HP	HIGH LEVEL PROBE
TS	WASH THERMOSTAT SWITCH
TM	TIMER MOTOR
VL	WATER LEVEL CONTROL
VCT	WASH CYCLE TIMER
CF	CONSTANT VOLTAGE CONNECTION
SF	SWITCHED VOLTAGE CONNECTION
RF	RINSE AID CONNECTION
DF	DETERGENT CONNECTION

### COMPONENT LAYOUT

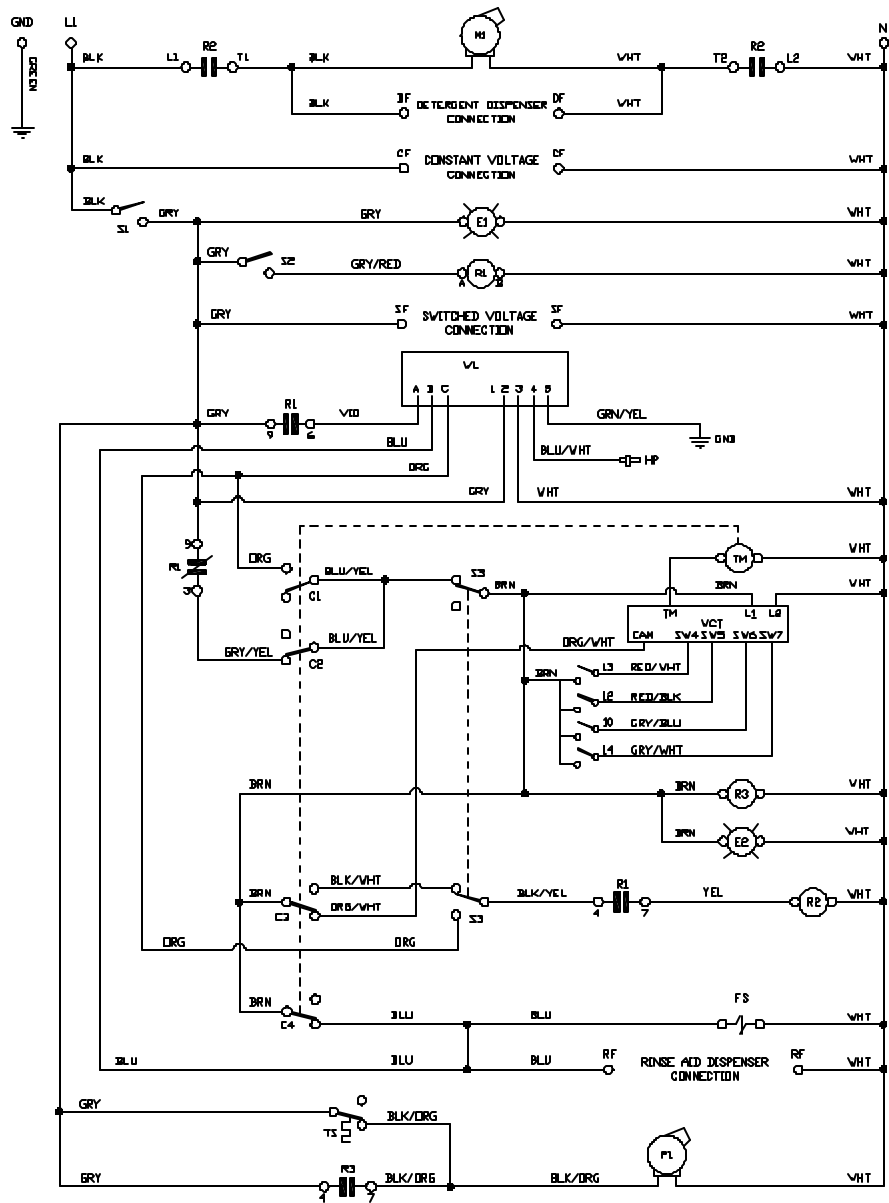
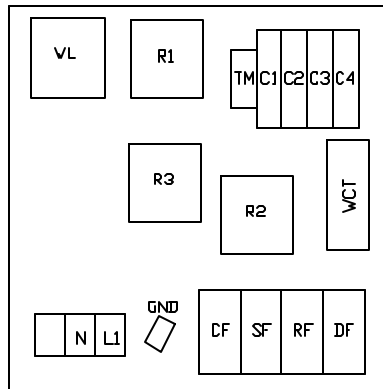

9905-002-57-61a

# SECTION 7: ELECTRICAL SCHEMATICS

## TEMPSTAR HH GPX 208-230 VOLT - 50/60 HERTZ - SINGLE PHASE

### LEGEND

- L1 L2 L3 POWER DISTRIBUTION BLOCK
- GND CHASSIS GROUND
- ML WASH PUMP MOTOR
- PL CIRCULATOR PUMP
- R1 CONTROL RELAY
- R2 WASH MOTOR CONTACTOR
- R3 WASH TEMPERATURE RELAY
- S1 POWER SWITCH
- S2 DOOR SWITCH
- S3 NORMAL/DELIME SWITCH
- S4 CYCLE SELECTOR SWITCH 1
- S5 CYCLE SELECTOR SWITCH 2
- S6 CYCLE SELECTOR SWITCH 3
- S7 CYCLE SELECTOR SWITCH 4
- C1 CYCLE SWITCH
- C2 AUTO START RESET SWITCH
- C3 WASH CYCLE SWITCH
- C4 RINSE/FILL SWITCH
- EL POWER LIGHT
- E2 CYCLE LIGHT
- FS FILL SOLENOID
- HP HIGH LEVEL PROBE
- TS WASH THERMOSTAT SWITCH
- TM TIMER MOTOR
- WL WATER LEVEL CONTROL
- WCT WASH CYCLE TIMER
- CF CONSTANT VOLTAGE CONNECTION
- SF SWITCHED VOLTAGE CONNECTION
- RF RINSE AID CONNECTION
- DF DETERGENT CONNECTION

### COMPONENT LAYOUT

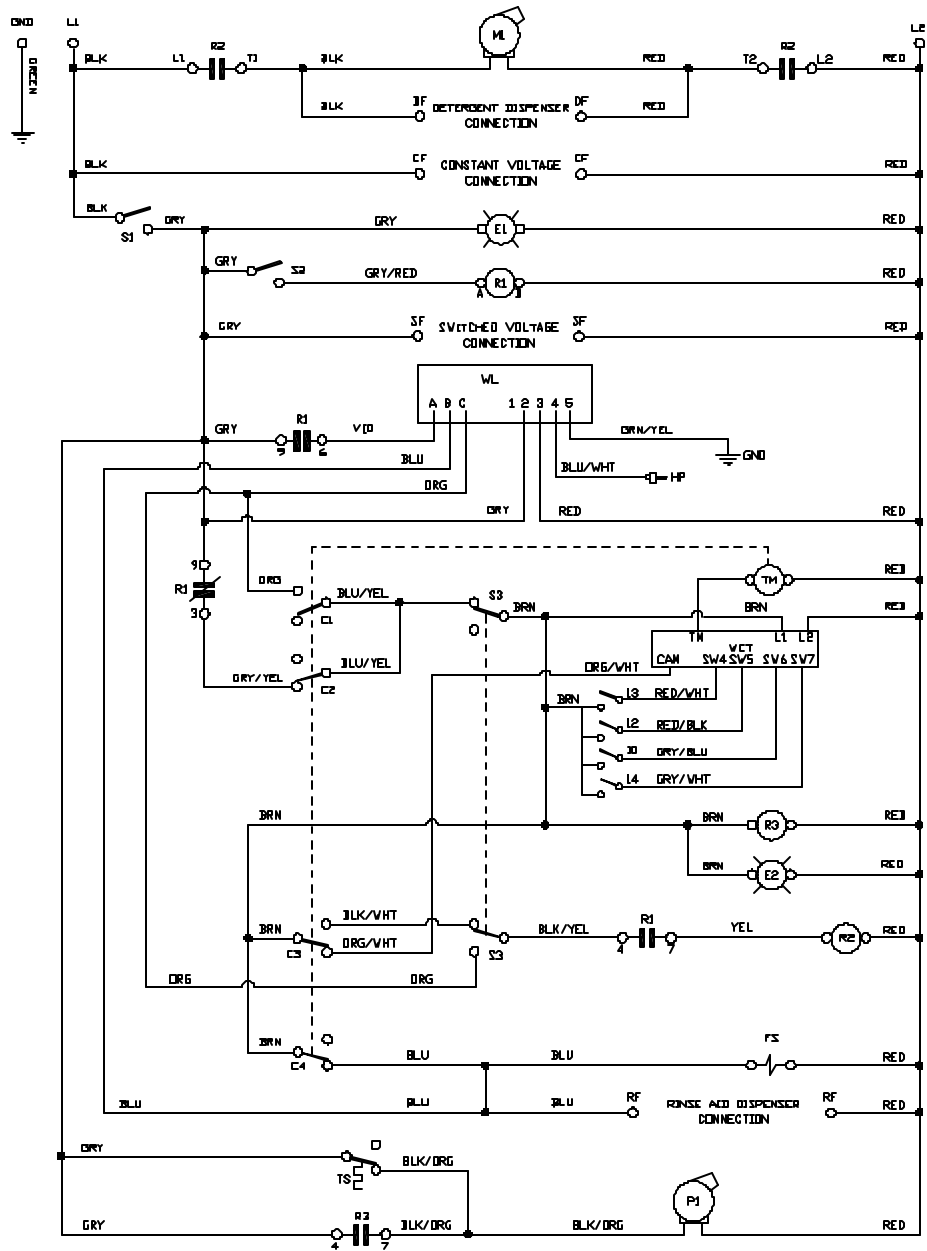
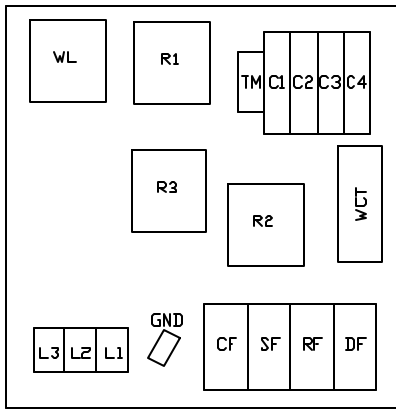

9905-002-57-60a

## SECTION 7: ELECTRICAL SCHEMATICS

### EXHAUST FAN CONTROL OPTION/SAFETY DOOR INTERLOCK (SDI) OPTION

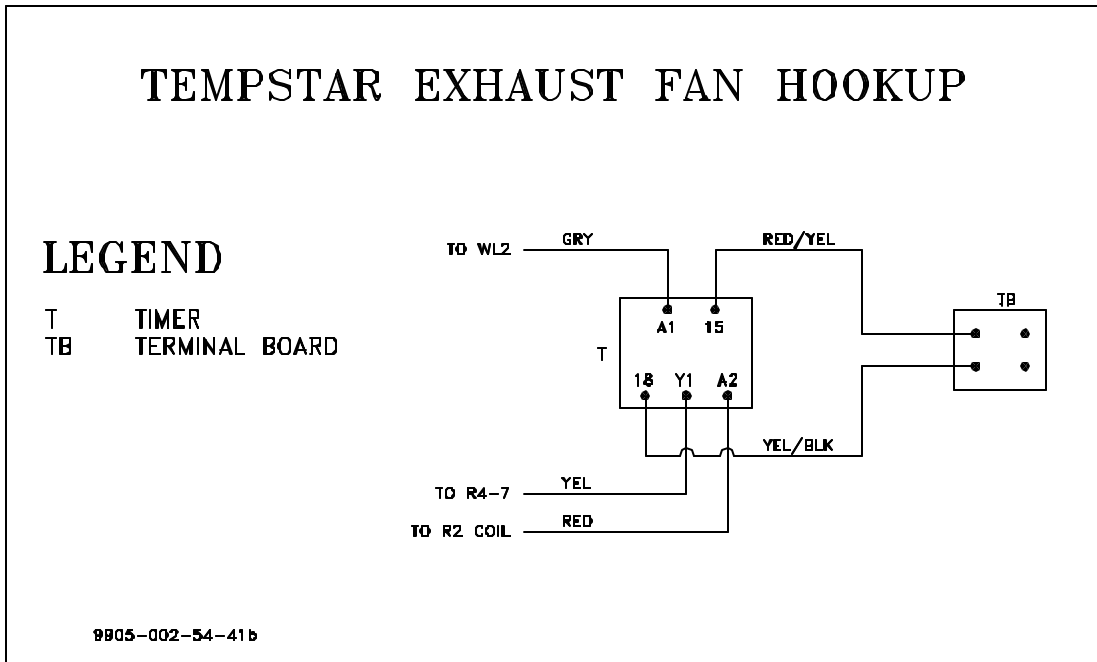

### TEMPSTAR SDI OPTION

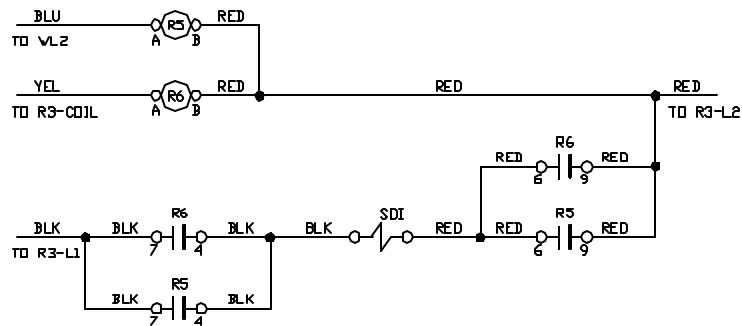

#### LEGEND

- R5     RINSE RELAY
- R6     WASH RELAY
- SDI    SAFETY DOOR INTERLOCK SOLENOID

09905-002-35-85a