

BADGER 5-82 BADGER 5-82A (With Cord)

Warranty:	2 Year Full Warranty
hp/Volts/Hertz:	1/2hp -120V / 60Hz
Production Date:	2/03
Engineer Number:	73134B/C

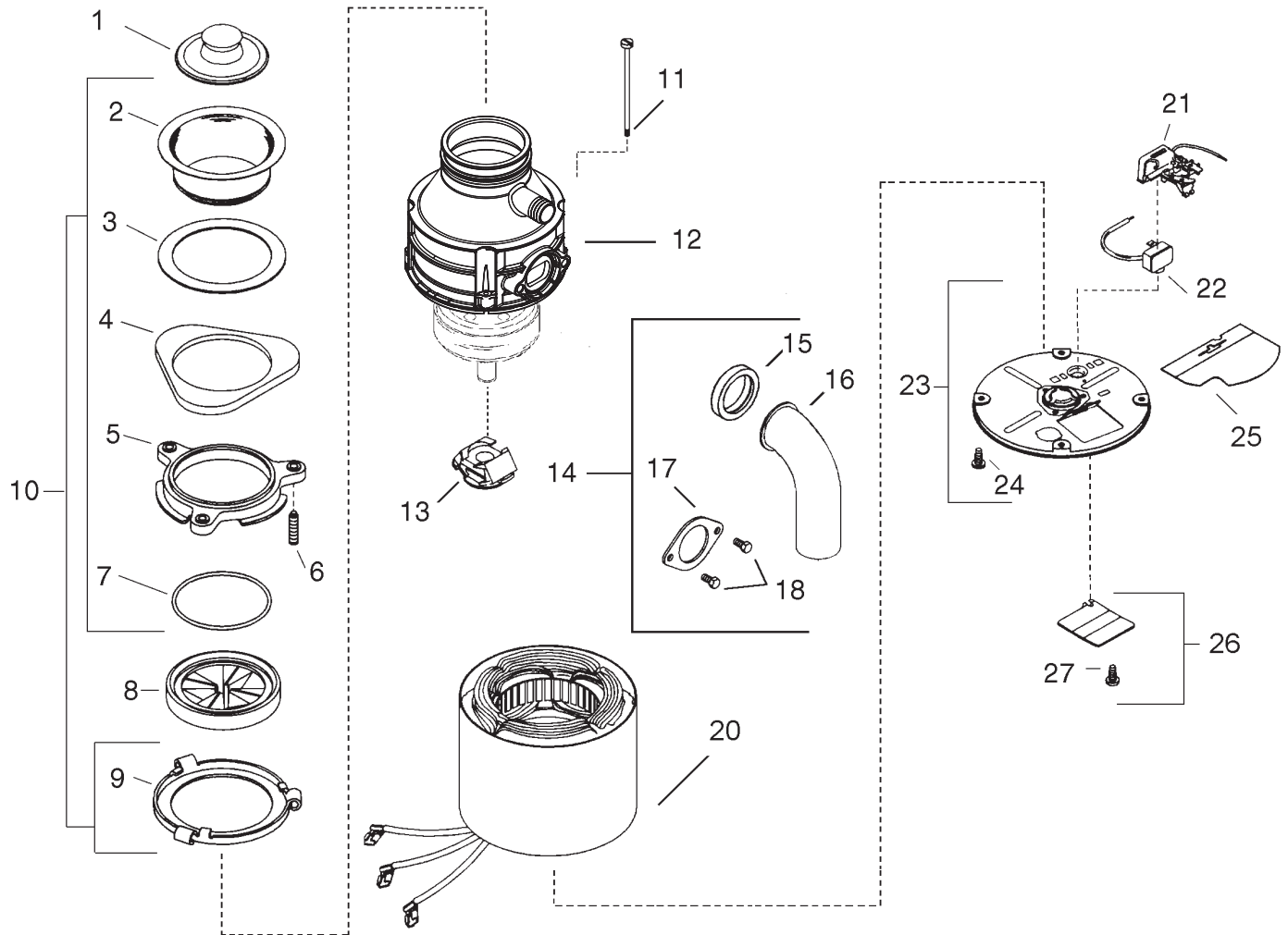

ORDER BY PART NUMBER, NOT CODE NUMBER

CODE NO.	PART NO.	NO. REQ.	DESCRIPTION	CODE NO.	PART NO.	NO. REQ.	DESCRIPTION
1	4310	1	Stopper Assembly	17	N/A	1	Tailpipe Flange
2	N/A	1	Sink Flange	18	N/A	2	Screw
3	N/A	1	Fiber Gasket	19	4577	1	Service Wrenchette (Not Shown)
4	N/A	1	Backup Ring	20	3255AN	1	Stator Assembly
5	N/A	1	Mounting Ring	21	3706C	1	Start Switch Assembly
6	N/A	3	Screw	22	2267BYZZ	1	Overload Protector
7	N/A	1	Snap Ring	23	71875D	1	End Frame Assembly (Includes Code 24)
8	70368	1	Mounting Gasket	24	N/A	1	Ground Screw
9	N/A	1	Body Flange	25	4134	1	Wire Shield
10	3173DA	1	Mounting Assy (Inc. Codes 2-7 & 9)	26	72647A	1	Terminal Cover Assy (Includes code 27)
11	73193A	4	Thru Bolt	27	N/A	1	Terminal Cover Screw
12	N/A	1	Enclosure Assembly (Not Available - Replace Unit)	28	73116	1	Installation, Care & Use Manual (Not Shown)
13	2467	1	Centrifugal Actuator Assy	29	70666	1	Bushing (Badger 5-82A only - Not Shown)
14	73130	1	Installation Kit (Includes codes 15-19)	30	2272	1	Cord (Badger 5-82A only - Not Shown)
15	N/A	1	Tailpipe Gasket				
16	N/A	1	Tailpipe				