



HOUSEHOLD DISPOSER (UL)

MODEL BADGER 1-79

1 Year Full Warranty

120V / 60Hz

1/3 H.P.

Start Date:
1/98
Engineer Number:
72003
Rev: **9/98**

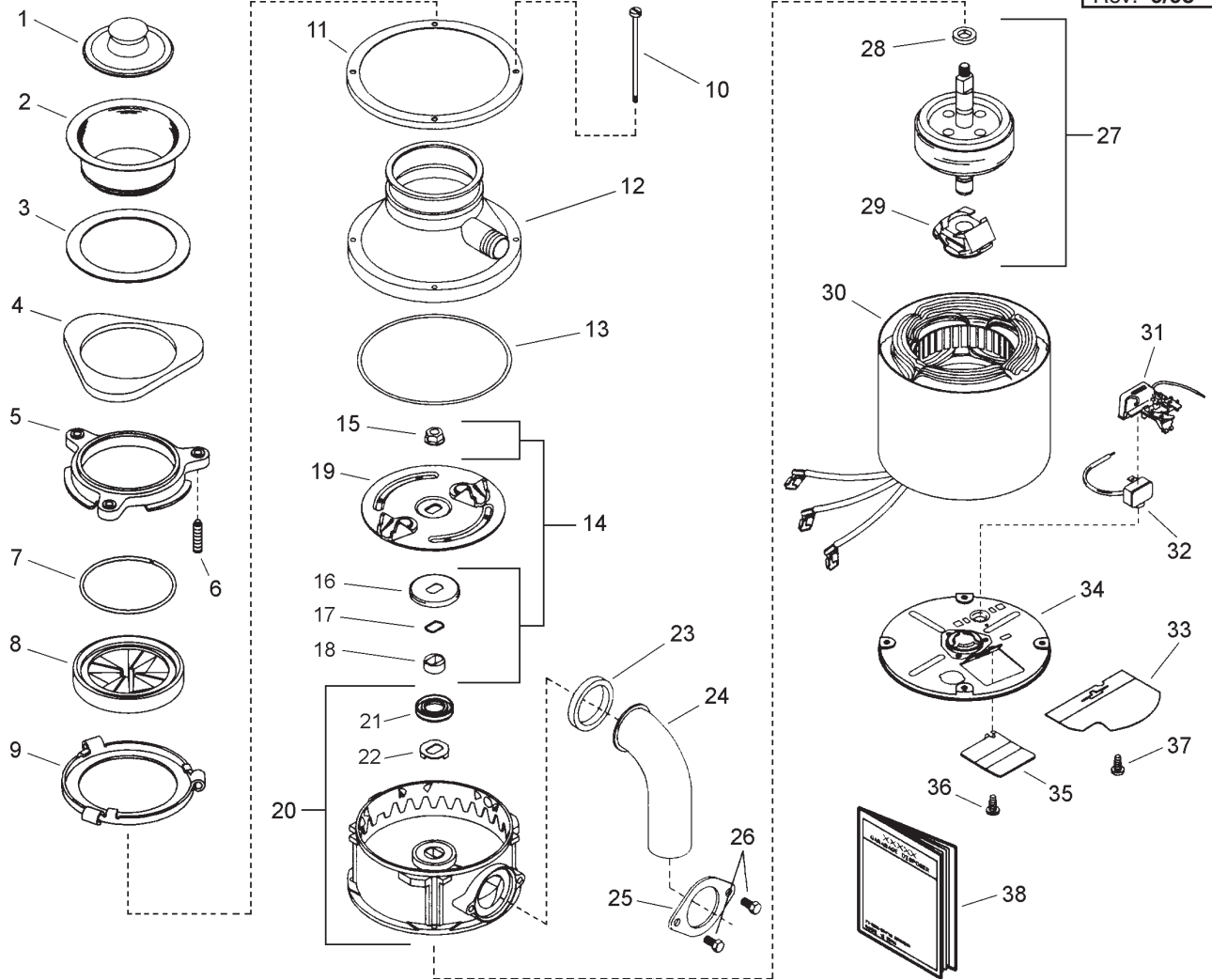

ORDER BY PART NUMBER, NOT CODE NUMBER

CODE NO.	PART NO.	NO. REQ.	DESCRIPTION	CODE NO.	PART NO.	NO. REQ.	DESCRIPTION
1	4310	1	Stopper Assembly	21	4250	1	Seal, Water & Oil
2	5170AC	1	Flange, Strainer	22	2292	1	Washer, Thrust
3	1160	1	Seal, Sink Flange	23	2592	1	Gasket, Tailpipe
4	5150E	1	Flange, Backup	24	8219	1	Tailpipe
5	5141	1	Flange, Mounting	25	2593A	1	Flange, Tailpipe
6	5147	3	Screw, Backup	26	1468	2	Screw, Tailpipe
7	5166	1	Ring, Retaining	27	4071B	1	Rotor & Shaft Assembly (Includes Codes 28 & 29)
8	70368	1	Gasket, Mounting	28	2642	1	Washer
9	5298	1	Flange, Body	29	2467	1	Centrifugal Actuator Assembly
10	71930	4	Bolt, Thru	30	4068P	1	Stator Assembly
11	9206	1	Clamping Ring	31	3706C	1	Switch Assembly, Start
12	70985N	1	Container Body (Includes Codes 11)	32	2267BY	1	Overload, Protector
13	1473	1	O-Ring	33	3622	1	Shield, Wire
14	70647	1	Sleeve & Seal Kit (Includes Codes 15-18)	34	71875	1	End Frame Assembly (Includes Code 37)
15	N/A	1	Nut, Flange	35	71387	1	Cover, Terminal
16	N/A	1	Slinger	36	70734	1	Screw, Terminal Cover
17	N/A	1	Seal	37	2466A	1	Screw, Ground
18	N/A	1	Sleeve	38	72050	1	Use & Care Booklet (English/Spanish)
19	3216B	1	Shredder Assembly, Rotating	39	2638BE	1	Instruction Assy (Not Shown) (Includes Codes 23-26)
20	8492AC	1	End Bell Assembly, Upper (Includes Codes 21 & 22)				