

OPERATOR MANUAL

Part Number 141601 Rev. B

OM-HY-6G

DOMESTIC

Model: HY-6G
HyPerSteam™
Atmospheric Convection
Steamer

Self-Contained
Gas

Capacity: 6 Steamer Pans
(12" x 20" x 2½")



THIS MANUAL MUST BE RETAINED FOR FUTURE REFERENCE. READ, UNDERSTAND AND FOLLOW THE INSTRUCTIONS AND WARNINGS CONTAINED IN THIS MANUAL.

WARNING

DO NOT STORE OR USE GASOLINE OR OTHER FLAMMABLE VAPORS AND LIQUIDS IN THE VICINITY OF THIS OR ANY OTHER APPLIANCE.

POST IN A PROMINENT LOCATION

INSTRUCTIONS TO BE FOLLOWED IN THE EVENT USER SMELLS GAS. THIS INFORMATION SHALL BE OBTAINED BY CONSULTING YOUR LOCAL GAS SUPPLIER. AS A MINIMUM, TURN OFF THE GAS AND CALL YOUR GAS COMPANY AND YOUR AUTHORIZED SERVICE AGENT. EVACUATE ALL PERSONNEL FROM THE AREA.

WARNING

IMPROPER INSTALLATION, ADJUSTMENT, ALTERATION, SERVICE OR MAINTENANCE CAN CAUSE PROPERTY DAMAGE, INJURY OR DEATH. READ THE INSTALLATION, OPERATING AND MAINTENANCE INSTRUCTIONS THOROUGHLY BEFORE INSTALLING OR SERVICING THIS EQUIPMENT.



IMPORTANT — READ FIRST — IMPORTANT

- WARNING:** THE UNIT MUST BE INSTALLED BY PERSONNEL QUALIFIED TO WORK WITH ELECTRICITY AND PLUMBING. IMPROPER INSTALLATION CAN CAUSE INJURY TO PERSONNEL AND/OR DAMAGE TO THE EQUIPMENT. THE UNIT MUST BE INSTALLED IN ACCORDANCE WITH APPLICABLE CODES.
- WARNING:** BEFORE REMOVING ANY PARTITION OR PANEL, TURN OFF THE ELECTRICAL POWER AND ALLOW THE FAN TO STOP ROTATING. BEFORE WORKING ON ANY ELECTRICAL COMPONENT DISCONNECT THE POWER SOURCE FROM THE UNIT.
- NOTICE:** Do not install the unit in any way which will block the right side vents, or within 12 inches of a heat source such as a braising pan, deep fryer, char broiler or kettle.
- NOTICE:** Level the unit front to back, or pitch it slightly to the rear, to avoid drainage problems.
- CAUTION:** MAKING ANY ELECTRICAL OR MECHANICAL CHANGE IN THE UNIT WITHOUT PRIOR APPROVAL FROM GROEN FOOD SERVICE ENGINEERING WILL VOID ALL WARRANTIES.
- WARNING:** TO AVOID DAMAGE OR INJURY, FOLLOW THE WIRING DIAGRAM EXACTLY WHEN CONNECTING A UNIT.
- CAUTION:** DO NOT USE PLASTIC PIPE. DRAIN MUST BE RATED FOR BOILING WATER.
- WARNING:** DO NOT CONNECT THE DRAIN DIRECTLY TO A BUILDING DRAIN.
- WARNING:** BLOCKING THE STEAM GENERATOR OR CAVITY DRAIN SCREEN MAY BE HAZARDOUS.
- IMPORTANT:** Improper drain connection will void warranty.
- WARNING:** WHEN YOU OPEN THE DOOR, STAY AWAY FROM STEAM COMING OUT OF THE UNIT. STEAM CAN CAUSE BURNS.
- WARNING:** ALL POTENTIAL USERS OF THE EQUIPMENT SHOULD BE TRAINED IN SAFE AND CORRECT OPERATING PROCEDURES.
- WARNING:** NO ATTEMPT SHOULD BE MADE TO OPERATE THIS EQUIPMENT DURING A POWER FAILURE.
- WARNING:** BEFORE CLEANING THE OUTSIDE OF THE STEAMER, DISCONNECT THE ELECTRIC POWER SUPPLY. KEEP WATER AND CLEANING SOLUTIONS OUT OF CONTROLS AND ELECTRICAL COMPONENTS. NEVER HOSE OR STEAM CLEAN ANY PART OF THE UNIT.
- WARNING:** ALLOW COOKING CHAMBERS TO COOL BEFORE CLEANING.
- WARNING:** CAREFULLY READ THE WARNINGS AND FOLLOW THE DIRECTIONS ON THE LABEL OF EACH CLEANING AGENT. USE SAFETY GLASSES AND RUBBER GLOVES AS RECOMMENDED BY DELIMING AGENT MANUFACTURER.
- WARNING:** DO NOT MIX DE-LIMING AGENTS (ACID) AND DE-GREASERS (ALKALI) IN THE STEAM GENERATOR OR ON THE COOKING CHAMBER WALLS.
- WARNING:** DO NOT PUT HANDS OR TOOLS INTO THE COOKING CHAMBER UNTIL THE FAN HAS STOPPED TURNING.
- WARNING:** DO NOT OPERATE THE UNIT UNLESS THE REMOVABLE RIGHT SIDE PANELS HAVE BEEN RETURNED TO THEIR PROPER LOCATIONS.
- NOTICE:** Do not use a cleaning or de-liming agent that contains any sulfamic acid or any chloride, including hydrochloric acid. If the chloride content of any product is unclear, consult the manufacturer.
- NOTICE:** Use no de-greaser that contains potassium hydroxide or sodium hydroxide or that is alkaline.
- WARNING:** USE OF ANY REPLACEMENT PARTS OTHER THAN THOSE SUPPLIED BY GROEN OR THEIR AUTHORIZED DISTRIBUTOR VOIDS ALL WARRANTIES AND CAN CAUSE BODILY INJURY TO THE OPERATOR AND DAMAGE THE EQUIPMENT. SERVICE PERFORMED BY OTHER THAN FACTORY-AUTHORIZED PERSONNEL WILL VOID ALL WARRANTIES.

Table of Contents

OPERATOR WARNINGS (READ FIRST) 2

EQUIPMENT DESCRIPTION 4

WATER QUALITY AND TREATMENT 5

INSPECTION AND UNPACKING 6

INSTALLATION AND START-UP INSTRUCTIONS 7

OPERATING INSTRUCTIONS 10

CLEANING 12

MAINTENANCE AND TROUBLESHOOTING 14

PARTS LISTS 15

ELECTRICAL SCHEMATICS 22

REFERENCES 23

SERVICE LOG 24

WARRANTY PROTECTION 25

Equipment Description

Your Groen HY-6G HyPerSteam Convection Steamer is designed to give years of service. It has two stainless steel cavities (cooking chambers) which are served by twin, independent atmospheric steam generators which are gas-heated. A powerful blower circulates the steam in each cavity, to increase heating efficiency.

Each cavity holds up to three steam table pans (12" x 20" x 2½"). A 16 gauge stainless steel cabinet encloses the cavities, the steam generators and the control compartment that houses electrical components. Door hinges are reversible (the doors may be set to open from the left or right). Operating Controls are on the front panel.

Newer model HY-6G steamers (manufactured since July 1999) are equipped with fully electronic controls and a button-activated, preprogrammed CLEAN cycle. These units are readily identified by their unique control panels. The On-Off switch on older models has been replaced by touch pad controls, and the distinctive symbol for steam is integrated into the panel design. The new model also has fewer panel louvers on the right side.

The drain system includes a spray condenser, which reduces condensate temperature and helps keep steam from escaping through the drain.



WARNING
BEFORE REMOVING ANY PARTITION OR PANEL, TURN OFF THE ELECTRICAL POWER AND LET THE FAN STOP ROTATING.

BEFORE WORKING ON ANY ELECTRICAL COMPONENT, DISCONNECT THE POWER SOURCE FROM THE UNIT.

BURNER FIRING RATES

Input Rates, BTU/hour	Natural Gas at 3.7" W.C.	L.P. Gas at 10.5" W.C.
Individual Steam Generator	45,000	45,000
Total, Both Cavities	90,000	90,000

Voltage: 108-126 VAC Single Phase 50/60 Hz
Current: 2.5 AMPs ± 10%

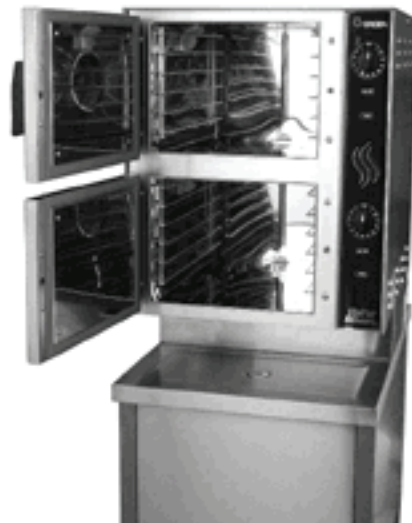

The HY-6G has two independent cavities, each with its own base-mounted steam generator.

WARNING
THE UNIT MUST BE INSTALLED BY PERSONNEL WHO ARE QUALIFIED TO WORK WITH ELECTRICITY AND PLUMBING. IMPROPER INSTALLATION CAN CAUSE INJURY TO PERSONNEL AND/OR DAMAGE TO THE EQUIPMENT. THE UNIT MUST BE INSTALLED IN ACCORDANCE WITH APPLICABLE CODES.

Water Quality and Treatment

It is essential to supply the steam generator with water that will not form scale. Even though the steam generator/boiler is engineered to minimize scale formation, scale development depends on the hardness of your water and the number of hours you operate the equipment each day.

Most water supplies contain minerals which form scale. It is this scale which could lead to an early component failure.

Your local water utility can tell you about the minerals in your water. The water going to the steam generator should have between 10 and 30 parts per million (ppm) total dissolved solids (TDS) and should have a pH (acidity rating) of 7.0 to 9.0. Please follow these simple precautions:

1. The best way to prevent scale is to use a Groen PureSteem™ Water Treatment System which has been specifically designed for Groen steamers and combination ovens. **Do not rely on unproven water treatment systems** sold for scale prevention and removal. **They are not specifically designed to work with Groen steamers and combination ovens.**
2. A well-maintained water treatment system and a regular cartridge replacement schedule is essential.
3. Using a Groen PureSteem™ Water Treatment System will provide longer steam generator/boiler life, higher steam capacity, and reduce maintenance requirements. To avoid mineral build up in the steam generator, blow down the generator after every 5 hours.
4. If you notice a slowdown in steam production or an increase in deliming, have the steamer checked for scale build-up. This could be an indication that the water treatment cartridges need replacing. Heavy scale reduces the unit's ability to boil water, and can even cause component failure.

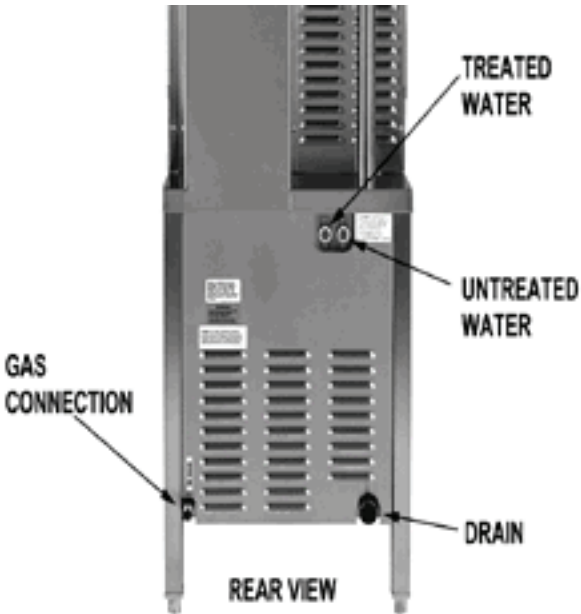

MINIMIZE SCALE PROBLEMS BY INSTALLING AND MAINTAINING A GROEN PureSteem™ WATER TREATMENT SYSTEM AND BY DELIMING THE STEAMER REGULARLY.

The Groen HY-6G Steamer features two separate water inlets — one for the steam generator/boiler (treated water), the other for the spray condenser (untreated water). The second intake will reduce treatment requirements resulting in significant savings.

The dual water connections are side by side on the rear of the unit. When seen from the back of the unit, the treated water intake is on the left.

Inspection and Unpacking

Your HY-6G HyPerSteam will be delivered completely assembled in a heavy shipping carton and attached to a skid. On receipt, inspect the carton carefully for exterior damage.

CAUTION
SHIPPING STRAPS ARE UNDER TENSION AND CAN SNAP BACK WHEN CUT.

Carefully cut the straps around the carton and detach the sides of the carton from the skid. Be careful to avoid personal injury. Strap edges may be very sharp, particularly where cut.

Write down the model number, serial number and installation date. Space for these entries is provided in the Service Log at the back of this manual. Keep the manual near the equipment for reference and update as needed.

CAUTION
THIS UNIT WEIGHS 550 POUNDS. GET HELP AS NEEDED AND USE MATERIAL HANDLING EQUIPMENT TO MOVE IT.

When installing, use material handling equipment to lift the unit straight up from the skid. Check packing materials for any loose parts.

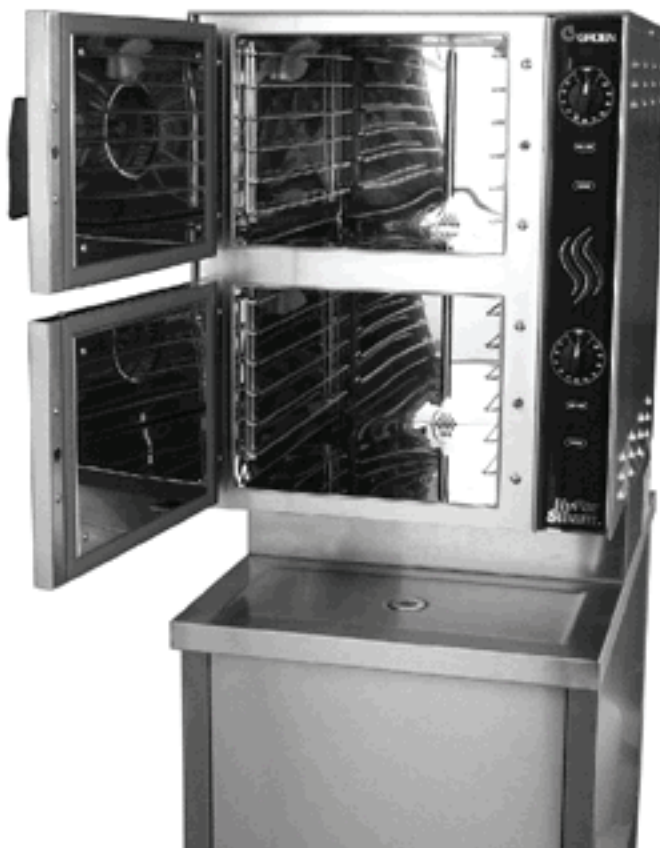

Installation and Start-Up

WARNING

THE UNIT MUST BE INSTALLED BY PERSONNEL WHO ARE QUALIFIED TO WORK WITH ELECTRICITY AND PLUMBING. IMPROPER INSTALLATION CAN CAUSE INJURY TO PERSONNEL AND/OR DAMAGE TO THE EQUIPMENT. THE UNIT MUST BE INSTALLED IN ACCORDANCE WITH APPLICABLE CODES.

CAUTION

DO NOT INSTALL THE UNIT WITH THE RIGHT SIDE VENTS BLOCKED OR WITHIN 12 INCHES OF A HEAT SOURCE (LIKE A BRAISING PAN, DEEP FRYER, CHAR BROILER, OR KETTLE).

TO AVOID DRAIN PROBLEMS, LEVEL THE UNIT FRONT TO BACK, OR PITCH IT SLIGHTLY TO THE REAR.

A. Installation

The HY-6G steamer is suitable for installation on or near both combustible and noncombustible surfaces.

Minimum installation clearances are:

Right Side	2 inches
Left Side	0 inches
Rear	6 inches

However, for easy service at least **12 inches** clearance is required for the **right** side of the unit, and it may **not be installed within 12 inches of a heat source**, as stated in the Caution above.

The unit must be installed in a well-ventilated room with an adequate air supply. The steamer must be installed beneath a ventilation hood, since gas combustion products exit the appliance.

Any item which might obstruct or restrict the flow of air for combustion and ventilation must be removed. Do not obstruct the flue cover or any front, side, rear, or top vents after installation.

The area directly around the appliance must be cleared of all combustible material. The installation must conform with local codes or, in the absence of local codes, with the National Fuel Gas Code, ANSI Z223.1, latest edition, including the following:

The unit and its individual shutoff valve must be **disconnected** from the gas supply system during any pressure testing of that system at test pressures **in excess of ½ PSI (3.45 kPa)**. It must be **isolated** from the gas supply piping system by closing its individual manual shutoff valve during any pressure testing of the gas supply piping system at test pressures **equal to or less than ½ PSI (3.45 kPa)**.

1. Electrical Supply Connection

Provide 115 VAC, 60 HZ, 1 PH, 15 AMP service. Bring conduit in through open frame on the under-side of cabinet. Local codes and/or the National Electrical Code should be observed in accordance with ANSI/NFPA 70-1987 (or latest edition). **AN ELECTRICAL GROUND IS REQUIRED.** The electrical schematic is located in the service compartment and in this manual.

Maximum load is 2½ AMPs. In Canada, provide electrical service in accordance with the Canadian Electrical Code, CSA C22.1 Part 1 and/or local codes.

2. Gas Supply Connection

Connection to the gas supply can be completed with ½" NPT pipe or approved equivalent. Although the immediate connection to the appliance is ½" NPT, gas supply piping must be large enough to provide 90,000 BTU/hr. Supply pressure must be at least 4.5" W.C. (maximum 14" W.C.) for natural gas or 12" W.C. (maximum 14" W.C.) for LP gas. In Canada, the installation must conform to the Canadian Gas Code, CAN 1-B149, Installation Codes for Gas Burning Appliances and Equipment and/or local codes.

After the unit has been connected to the gas supply, all gas joints must be checked for leaks.

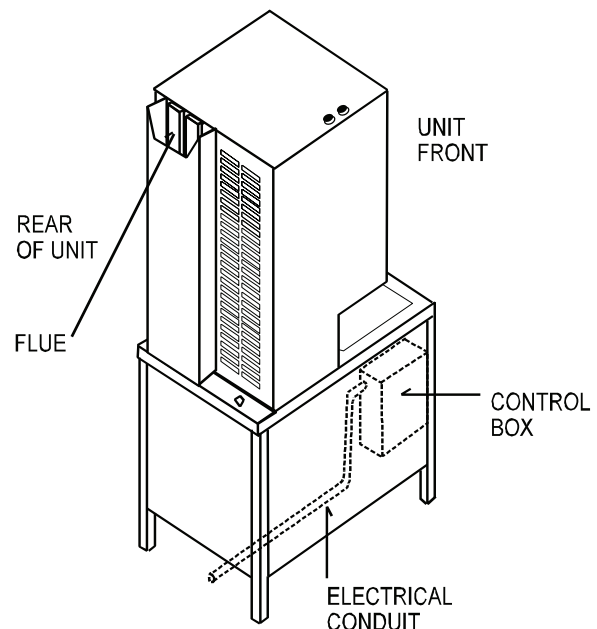

The knockout hole is sized for a one inch conduit fitting. Pass the wire up the back through this knockout hole to the front. Make the connections from the front.

OM-HY-6G

No flame should be used when checking for leaks. A thick soap solution or other suitable leak detector should be used.

For a unit on casters, complete connection to the gas supply with connectors that comply with the standard for connectors for moveable gas appliances, ANSI Z21.69 — latest edition. Restrain movement of the unit by attaching a cable or chain to the eyelet (provided at the back of the frame) and anchoring the cable or chain to the wall or floor. Make the length and location of the cable such that the unit cannot pull on the gas connection while the cable is connected.

3. Water Connection

A back siphonage device (check valve) must be installed in the incoming cold water line according to local plumbing code. The water line pressure should be between 30 and 60 PSI. A pressure regulator is required above 60 PSI. A ¾ inch NH (garden hose type) connector is required to connect the water supply to the water inlet valve. The minimum diameter of the water feed line is ½ inch. Use one washer (or, if necessary, two washers) in the hose connection. Do not allow the connection to have any leak, regardless of how small.

3A Untreated Water Second Connection

As discussed on Page 5, above, the flow of water used for steam suppression in the drain is much greater than the amount of water used to generate steam. An option available with these steamers (see illustration) permits the installer to supply treated water to the steam generator and untreated water to the drain. If your steamer has this “split water” option, the initial fill requirement for treated water is 3.5 U.S. gallons (19 L) within 2.5 minutes. The requirement for treated make-up water is 0.12 gallon (0.45 L) per minute per cavity. A field retrofit kit is available for existing units with no second water connection.

4. Drain Connection

The HY-6G Steamer must be leveled front to back. A 1½ inch (38mm) ID hose may be attached to the drain pipe (supplied) by means of a hose. **DO NOT CONNECT THE HOSE DIRECTLY TO A BUILDING DRAIN.** There must be a free air gap between the end of the hose and the building drain. The free air gap should be as close as possible to the unit drain. There must also be no other elbows or other restrictions between the unit drain and the free air gap.

Do NOT use plastic pipe. The drain must withstand boiling water.

Install the drain line with a constant downward pitch. **Do not allow any water traps in the line. A trap can cause pressure to build up inside the cavity during steaming, which will make the door gasket leak.**

B. INITIAL START-UP

After the HY-6G Steamer has been installed, test it to ensure that the unit is operating correctly.

1. Remove all literature and packing materials from the interior and exterior of the unit.
2. Make sure the water supply line is open.
3. Make sure that the gas supply line is open and that the manual knob on the main gas valve is turned to the “on” position. This valve is located behind the front access panel on the right side of the unit.
4. Turn on electrical service to the unit. The HY-6G will not operate without electrical power. Do not attempt to operate the unit during a power failure.
5. The steamer will not operate until the pilot burner has been ignited. To light the pilot burner, activate the pilot switch located next to the main gas valve. When the pilot ignition sequence has been successfully completed, a green light - on the pilot switch (old models) - and on the electrical panel (new models) will glow.
6. The “trial for ignition” period is roughly 90 seconds. If the pilot burner does not light within about 90 seconds after the switch is activated, the ignition system automatically stops gas flow to the pilot burner and stops the ignition trial. If this happens, turn off the pilot switch and repeat the trial for ignition. During the initial start-up, the pilot may require several trials for ignition until all the air is bled from the gas piping. Subsequent start-ups should require only about 5 seconds to achieve pilot ignition.

NOTE: See Automatic Operation of Pilot at the end of this section.

7. Once the pilot burner flame has been established (the green light on the pilot switch (old models) or electrical panel (new models) is on), press the “ON” switch for the desired steamer cavity. The steam generator will fill with water.

NOTE: The door **MUST** be closed for the main burner to work.

8. When the steam generator has filled with water, the burners will ignite automatically. Within approximately 8-10 minutes the READY light will come on, indicating that the water has reached its standby temperature. When the READY light is displayed, you may take any one of the following steps:
 - a. Set the timer to the desired time for timed steaming.
 - b. Turn the timer knob to the manual ON position for continuous steam.
 - c. Let the unit stay at standby temperature.



WARNING
WHEN YOU OPEN THE DOOR, STAY AWAY FROM STEAM COMING OUT OF THE UNIT. THE STEAM CAN CAUSE BURNS.

9. To shut down the unit, press the ON switch into the off position. The steam generator will then drain. You may also switch off the pilot switch to conserve energy.
10. If the HY-6G Steamer behaves as described, the unit is functioning correctly and ready for use.

Automatic Operation of Pilot

Once the pilot burner is lit, it essentially functions as a standing pilot. In this state, if the pilot is accidentally extinguished (by a very strong gust of wind for example), it will re-ignite automatically. The unit will completely shut down. Operator must turn off and then back on to reset. Then the unit will come back on and resume operation in the mode and with the (running) timer value existing just prior to shutdown. The pilot switch may be turned off during "off hours" to conserve energy.

After the unit has been running, if the pilot burner ever fails to re-ignite automatically within 90 seconds, wait 5 minutes before you attempt to reactivate it. In the unlikely event that ignition problems persist, contact your authorized Groen Service Agency.

NOTE: For operation at high altitudes (2000 feet and above) please consult the Groen Food Service Engineering Department.

Operation

WARNING

ALL POTENTIAL USERS OF THE EQUIPMENT SHOULD BE TRAINED IN SAFE AND CORRECT OPERATING PROCEDURES.

NO ATTEMPT SHOULD BE MADE TO OPERATE THIS EQUIPMENT DURING A POWER FAILURE.

NOTE: Before the steamer can be operated as described in this section, the pilot burner flame must be established. For details see the Initial Start-Up section and the Automatic Operation of Pilot, above.

A. Controls

Operator controls are on the front right of the unit.

The **control panel on new models** has the following touch pads and indicator lights:

- ! The ON/OFF touch pad gets the HyPerSteam ready for use, or shuts it off.
- ! The READY indicator light shows that the steam generator is at standby temperature and the cavity is hot enough to begin steaming.
- ! The DELIME indicator light is lit when the unit is operating in the cleaning mode.
- ! The SERVICE indicator light shows when the water level probes have stopped working, and need to be cleaned (normally an indication of lime deposits).

When one probe is not working, the DELIME light flashes briefly every few seconds. If both probes fail the SERVICE light will come on continuously and the beeper will sound.

- ! The HI TEMP indicator light comes on when the steam generator is too hot.

The unit will automatically shut off, and cannot be turned on again until the steam generator cools and the HI TEMP indicator light goes out.

- ! The TIMING indicator light stays on when the timer is running.
- ! The CLEAN touch pad is used to start the automatic 50 minute cleaning cycle.

The timer is used in three ways:

- 1 In the OFF position the steam generator stays at a low boil or “holding” temperature.
- 2 When a cook time is set, the unit steams until the timer runs down to OFF. Steaming stops,

the DONE light (a red light on older models) comes on and a beeper sounds.

- 3 With the timer turned to the ON position, the unit steams continuously. The green light stays lit. The steamer will **not** time down.

B. Operating Procedure

1. Press the ON switch/pad for the steamer. The steam generator will fill, and heat until the READY light comes on. (Approx. 10 minutes.)
2. Load food into pans in uniform layers. Pans should be filled to about the same levels, and should be even on top.
3. Open the door and slide the pans onto the supports. If you will only be steaming one pan, put it in the middle position.
4. Close the door. With the READY indicator lit, take one of the following steps:
 - ! If you want to steam the food for a certain length of time, set the timer for that period. The timer will automatically run the steamer for the set time and then turn it off. A red light will come on and a beeper will sound. Steam production stops.
 - ! If you want to steam continuously, turn the timer to the manual ON position. A green light will come on. The unit will continue steaming until you stop it by turning the timer to OFF. When steaming continuously **YOU MUST CONTROL STEAMING TIME.**

WARNING
WHEN YOU OPEN THE DOOR, STAY AWAY
FROM THE STEAM COMING OUT OF THE UNIT.
THE STEAM CAN CAUSE BURNS.



5. Open the door. Remove the pans from the steamer, using hot pads or oven mitts to protect your hands from the hot pans.
6. To shut down the unit, press the ON/OFF touch pad. The steam generator will automatically drain.



Cleaning

To keep your HY-6G Steamer in proper working order, use the following procedure to clean the unit. This regular cleaning will reduce the effort required to clean the steam generators and cavities.

A. Suggested Tools

1. Mild detergent
2. Stainless steel exterior cleaner such as Zepper®
3. Steam generator de-liming agent, such as **Groen Delimer Descaler**, Lime-Away® or an equivalent. A liquid de-liming agent will be easier to use than crystals or powders. See the warning about chlorides, below
4. De-greaser, such as EncompasS®, Malone 34®, Puritan Puribrute®, or Con-Lie®
5. Cloth or sponge
6. Plastic wool or a brush with soft bristles
7. Spray bottle
8. Measuring cup
9. Nylon pad
10. Towels
11. Plastic disposable gloves
12. Funnel



B. Procedure

1. Outside

- a. Prepare a warm solution of the mild detergent as instructed by the supplier. Wet a cloth with this solution and wring it out. Use the moist cloth to clean the outside of the unit. Do not allow freely running liquid to touch the controls, the control panel, any electrical part, or any open louver.
- b. To remove material which may be stuck to the unit, use plastic wool, a fiber brush, or a plastic or rubber scraper with a detergent solution.
- c. Stainless steel surfaces may be polished with a recognized stainless steel cleaner such as Zepper®.



WARNING

DISCONNECT THE POWER SUPPLY BEFORE CLEANING THE OUTSIDE OF THE STEAMER.

KEEP WATER AND CLEANING SOLUTIONS OUT OF CONTROLS AND ELECTRICAL COMPONENTS. NEVER HOSE OR STEAM CLEAN ANY PART OF THE UNIT.

DON'T MIX DE-LIMING AGENTS (ACID) WITH DE-GREASERS (ALKALI) ANYWHERE IN THE UNIT

AVOID CONTACT WITH ANY CLEANERS, DE-LIMING AGENT OR DE-GREASER AS RECOMMENDED BY THE SUPPLIER. MANY ARE HARMFUL. READ THE WARNINGS AND FOLLOW THE DIRECTIONS!

EVEN WHEN THE UNIT HAS BEEN SHUT OFF, DON'T PUT HANDS OR TOOLS INTO THE COOKING CHAMBER UNTIL THE FAN HAS STOPPED TURNING.

DON'T OPERATE THE UNIT UNLESS THE TWO REMOVABLE INTERIOR PARTITIONS HAVE BEEN PUT BACK IN THEIR PROPER LOCATIONS.

DON'T USE ANY CLEANING OR DE-LIMING AGENT THAT CONTAINS ANY SULFAMIC AGENT OR ANY CHLORIDE, INCLUDING HYDROCHLORIC ACID (HCl). TO CHECK FOR CHLORIDE CONTENT SEE ANY MATERIAL SAFETY DATA SHEETS PROVIDED BY THE CLEANING AGENT MANUFACTURER.

IMPORTANT

DO NOT USE ANY METAL MATERIAL (SUCH AS METAL SPONGES) OR METAL IMPLEMENT (SUCH AS A SPOON, SCRAPER OR WIRE BRUSH) THAT MIGHT SCRATCH THE SURFACE. SCRATCHES MAKE THE SURFACE HARD TO CLEAN AND PROVIDE PLACES FOR BACTERIA TO GROW. DO NOT USE STEEL WOOL, WHICH MAY LEAVE PARTICLES IMBEDDED IN THE SURFACE WHICH COULD EVENTUALLY CAUSE CORROSION AND PITTING.

2. Steam Generator and Cooking Chamber

Regular deliming, depending on your steamer usage and local water quality, must be done to enhance performance and prolong the life of your HyPerSteam™ convection steamer. Steamer must be turned off after every use to prevent lime scale buildup - do not run steamer continuously.

ALWAYS USE HOT PADS OR MITTS WHEN HANDLING HOT STEAMER PANELS OR RACKS.

RECOMMENDED TOOLS & CLEANERS:

- Groen Delimer/Descaler (Part Number 114800). **Do NOT use any product containing chlorides or sulfamic acid, including hydrochloric acid .**
- Nylon scrub pad, cloth and/or sponge

STEP 6- Delime cycle will start, taking about 30 minutes. When delime cycle is complete, DELIME light will appear, DONE light will flash and beeper will beep.

STEP 7- Press ON/OFF to turn steamer off. Let cavity cool for 5 minutes or longer. Open door, wipe out inside of cavity and wipe door gasket. Close door.

STEP 8- To use steamer, press ON/OFF. When READY light appears, steamer is ready to use.

DELIMING STEPS HY-6G (Use Touch Pad):

STEP 1 - Press ON/OFF to turn steamer off. Open door.

STEP 2 - **Let cavity cool for 5 minutes or longer.** While cool, wipe out cavity. Close door.

STEP 3 - Press and hold CLEAN while also turning steamer on by pressing ON/OFF, until only DELIME and POWER lights remain on (all lights will turn on, then off, except DELIME and POWER).

STEP 4- After 5 minutes, beeper will beep rapidly, signaling you to add Groen Delimer/Descaler. Door(s) must remain closed for entire delime cycle.

STEP 5- Pour 1 pint (2 cups) of delimer PER CAVITY into upper and /or lower delimiting port(s) and then close port(s). Press CLEAN. Double-stacked unit cavities may be delimed together or separately

NOTES:

- If DELIME light flashes rapidly (5 times per second), press DELIME to restart delime cycle.
- If power outage occurs during delimiting, delime cycle must be restarted. Press DELIME.
- For best performance, do not interrupt delime cycle. If delime cycle must be stopped, press ON/OFF to turn on. Set timer for 5 minutes. After beeper beeps, press ON/OFF to turn off. **Let cavity cool for 5 minutes or longer**, carefully open door(s) and wipe out cavity completely.

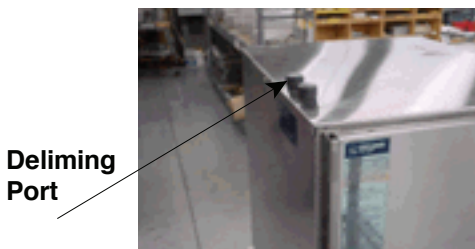

Maintenance

The HY-6G Steamer is designed for minimum maintenance, and no user adjustments should be necessary. Certain parts may need replacement after prolonged use. If there is a need for service, only Groen personnel or authorized Groen representatives should perform the work.

Always supply water with a low mineral count that meets the standards outlined in the **Water Conditioning** section of this manual.

The unit contains no fuses that should be replaced by the operator.

If steam or condensate is seen leaking from around the door, take the following steps:

1. Check the door gasket. Replace if it is cracked or split.

2. Inspect the cooking chamber drain to be sure it is not blocked.
3. Adjust the latch pin to allow for changes that might occur as the gasket ages.
 - a. Loosen the lock nut at the base of the latch pin. Turn the latch pin ¼ turn clockwise, and re-tighten the lock nut.
 - b. After adjustment, run the unit to test for further steam leakage.
 - c. If there is still leakage, repeat the adjustment.
 - d. Continue adjusting the pin clockwise until the door fits tightly enough to prevent leakage.

Troubleshooting

This Groen Steamer is designed to operate smoothly and efficiently if properly maintained. However, the following is a list of checks to make in the event of a problem. Wiring diagrams are furnished inside the service panel. If an item on the check list is marked with (X), it means that the work should be done by a factory-authorized service representative.

SYMPTOM	WHO	WHAT TO CHECK <small>(If item is marked X, work should be done by a factory authorized service rep)</small>
Pilot will not light	User	a. Are electrical connections made with a ground? b. Is gas supply connection made? c. Is pilot ignition switch on? d. Is gas valve turned on? e. Are building fuses or circuit breakers all right? f. Are there drafts which could blow out the pilot?
	Auth Service Rep Only	g. Is spark ignition cable connected to module? (X)
Steam generator does not fill with water.	User	a. Is the ON switch depressed? b. Is the water supply connected? c. Is the water turned on? d. Check for low water pressure (less than 30 PSI or 210 kPa). e. Is the screen at the water connection clogged? f. Has the steam generator been delimed?
No steam.	User	a. Is the ON switch depressed? b. Is the water supply connected? c. Is the water turned on? d. Are steamer doors open? e. Is the steam generator limed up?
Red light comes on after four minutes.	User	a. Is the water supply connected? b. Is the water turned on? c. Has the unit been delimed? (Refer to Cleaning Section)
Excessive steam escaping from rear of unit	User	a. Is the water spray hose kinked or obstructed?
	Auth Service Rep Only	b. Is the water spray solenoid connected?(X) c. Is the drain properly vented? (X)

Parts List

External Cabinet and Sheet Metal

To order parts, contact your authorized Groen Service Agency. Supply the model designation, part description, part number, quantity, and where applicable, voltage and phase.

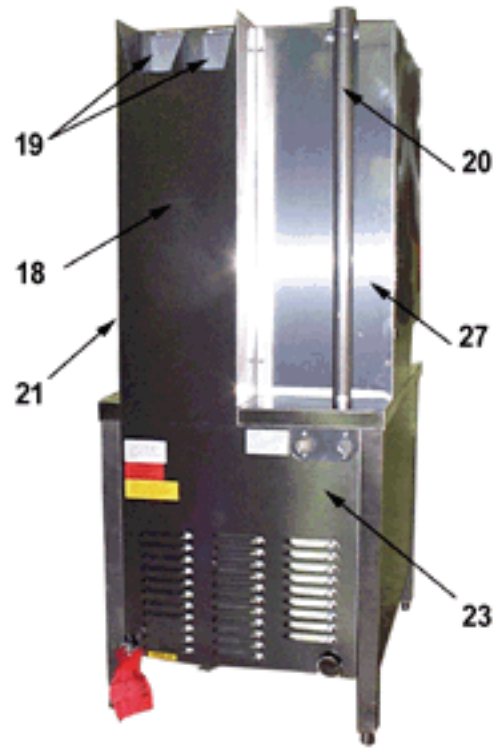
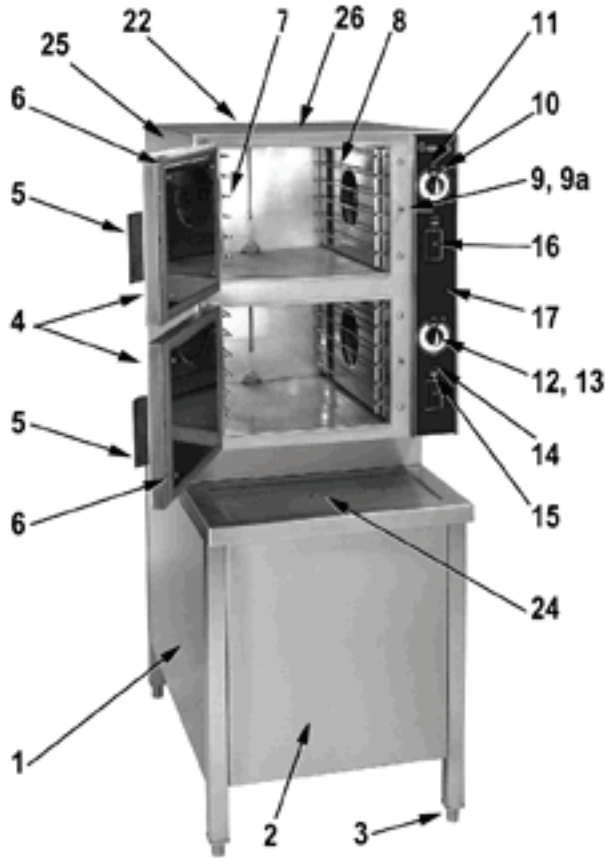

Key	Description	Part #
1	Lower Side Panels	096848
2	Lower Front Panel	096720
3	Adjustable Table Leg	042505
4	Door Assembly	130858
5	Door Handle	129723
6	Door Gasket	124849
7	Left Pan Rack	094148
8	Blower Cover/Rack	096788
9	Door Locking Pin	078914
9a	Door Pin Lock Nut	003823
10	Timer	096826
11	Timer Knob	123100
12	Mylar Overlay Plate	123128
13	Flue Cover	096765

Key	Description	Part #
14	Flue	096854
15	Vent Pipe	141346
16	Upper Right Side Panel	123183
17	Top Side Cover	096732
18	Lower Back Panel	096785
19	Sink Drain Fitting	099943
20	Upper Left Panel	123184
21	Top Panel	123182
22	Back Panel	125799

x - Part Not Required

**Parts List
Cavity Control Section**

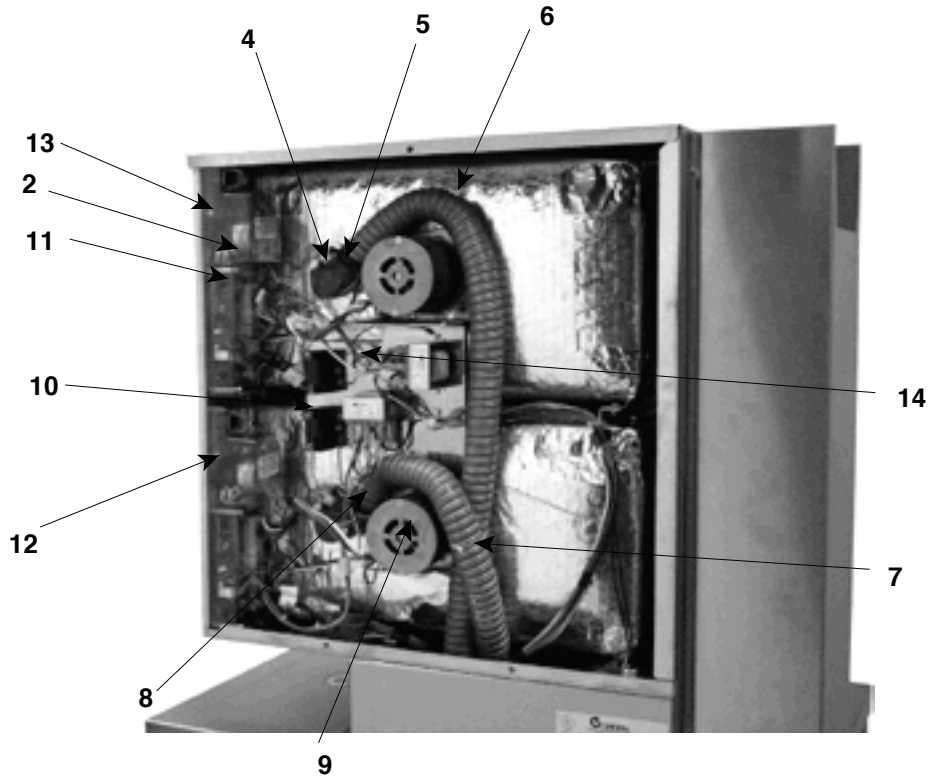

Key	Description	Part #
x	Top Cover Clip	123156
2	Timer	096826
x	Door Switch	096857
4	Ready Thermostat	088865
5	Steam Port	141366
6	Steam Hose, Top	141461
7	Steam Hose, Bottom	141462
8	1cl" Hose Clamp	127525
9	Fan Motor	096740
10	Motor Capacitor	096812
11	Control Board	141082

Key	Description	Part #
12	Light & Timer PC Board Assy	137233
13	Cover, Control Panel	119806
14	Chassis, Trfmr/Capacitor Assy	119864

x - Part Not Shown

Parts List Steamer Base Section

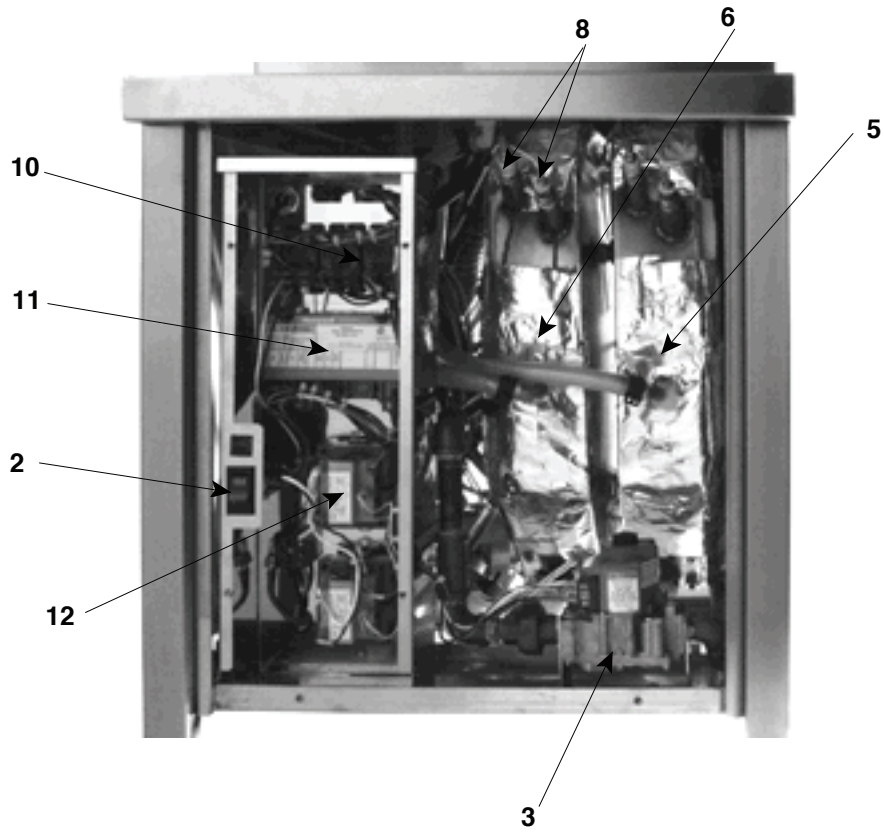

Key	Description	Part #
x	Adjustable Table Leg	042505
2	Gas Switch	087951
3	Main Gas Valve, Natural Gas	098443
	Main Gas Valve, Propane Gas	098444
x	Alternate Main Gas Valve	099988
5	Outer Steam Generator Assy	141618
6	Inner Steam Generator Assy	141618
x	Water Fill Hose	096772
8	Water Level Probe Right	141285
	Water Level Probe Left	141424
x	High Limit Thermostat	096892
10	Terminal Block	003887

Key	Description	Part #
11	Igniter Module	085153
12	120/24 Volt Transformer	121716

x - Part Not Shown

Parts List Steamer Base Section

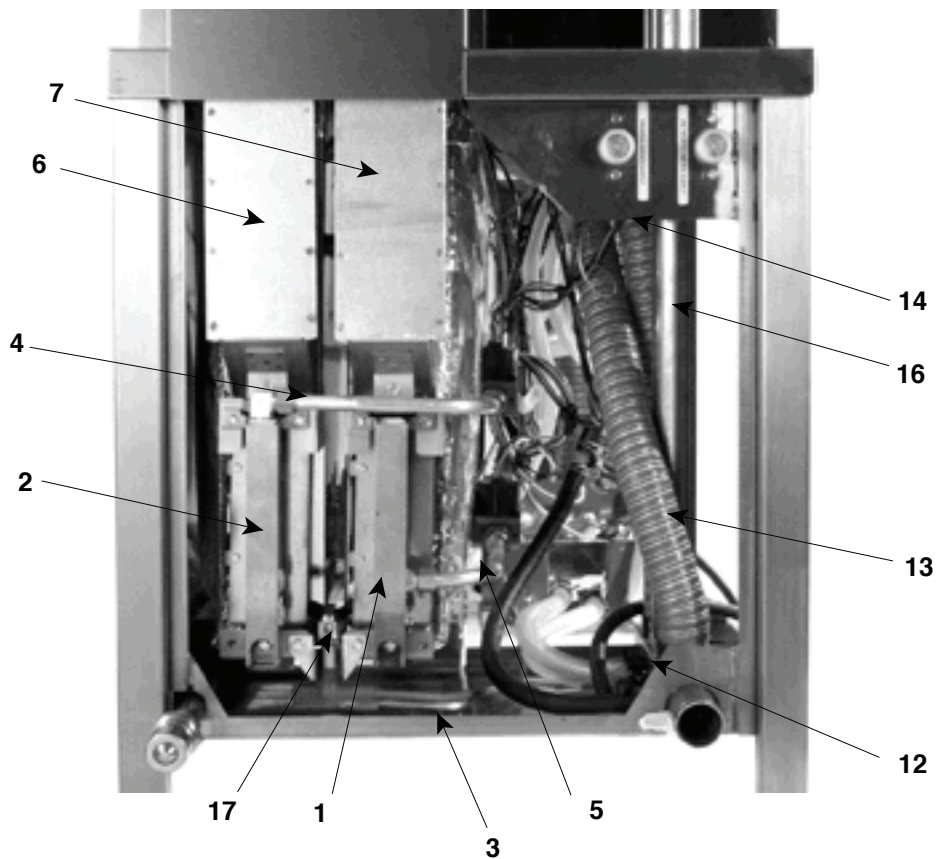

Key	Description	Part #
1	Inner Gas Manifold	141499
2	Outer Gas Manifold	141348
3	Igniter Cable	096728
4	1/2" Outer High Heat Tube	141338
5	1/2" Inner High Heat Tube	141339
6	Outer Flue	096854
7	Inner Flue	096854
x	Steam Generator Drain Valves	074594
x	Inner Generator Drain Hose	141467
—	Water inlet mounting for 2 outlet split water *	071235

Key	Description	Part #
x	Outer Generator Drain Hose	141466
x	Stm Gen Drain Hose Clamps	095656
12	Drain Box	140859
13	Upper Cavity Drain Hose	141490
14	Lower Cavity Drain Hose	141491
x	Cavity Drain Hose Clamp	126011
16	Vent Pipe	141346
x	Water Inlet Valve 3 outlet	090827
18	Pilot Burner - Natural Gas	096705
x	Pilot Burner - Propane Gas	096706
—	Water inlet valve, for second inlet on split water *	100934

x - Part Not Shown

**Parts List
Steamer Motor and Controls**

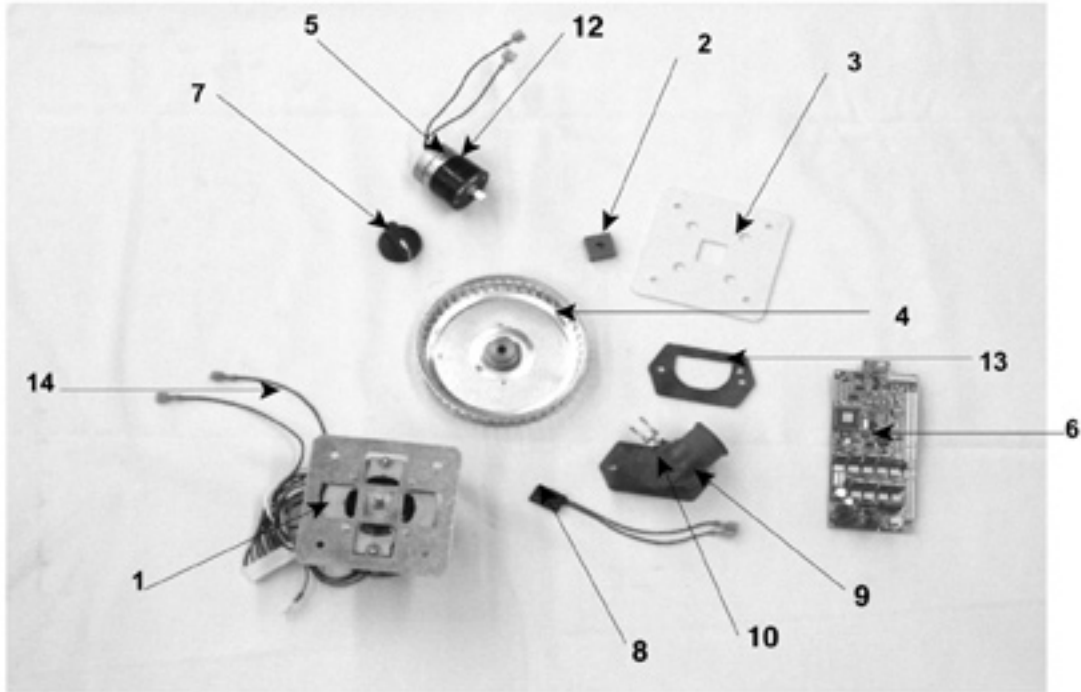

Key	Description	Part #	Key	Description	Part #
1	Fan Motor w/Mounting Plate	096740	8	Door Switch	096857
2	Motor Shaft Seal	096868	9	Steam Port Kit*	141617
3	Motor Insulator	094135	10	-Ready Thermostat	088865
4	Fan	096790	11	-Steam Port Gasket	099250
5	Timer	096826		*Includes Steam Port, Ready Thermostat and Steam Port Gasket	
6	Control Board	141082	12	Timer Fastener Nut	101145
7	Timer Knob	123100			

X - Part Not Required

Parts List Steam Generator Individual Parts

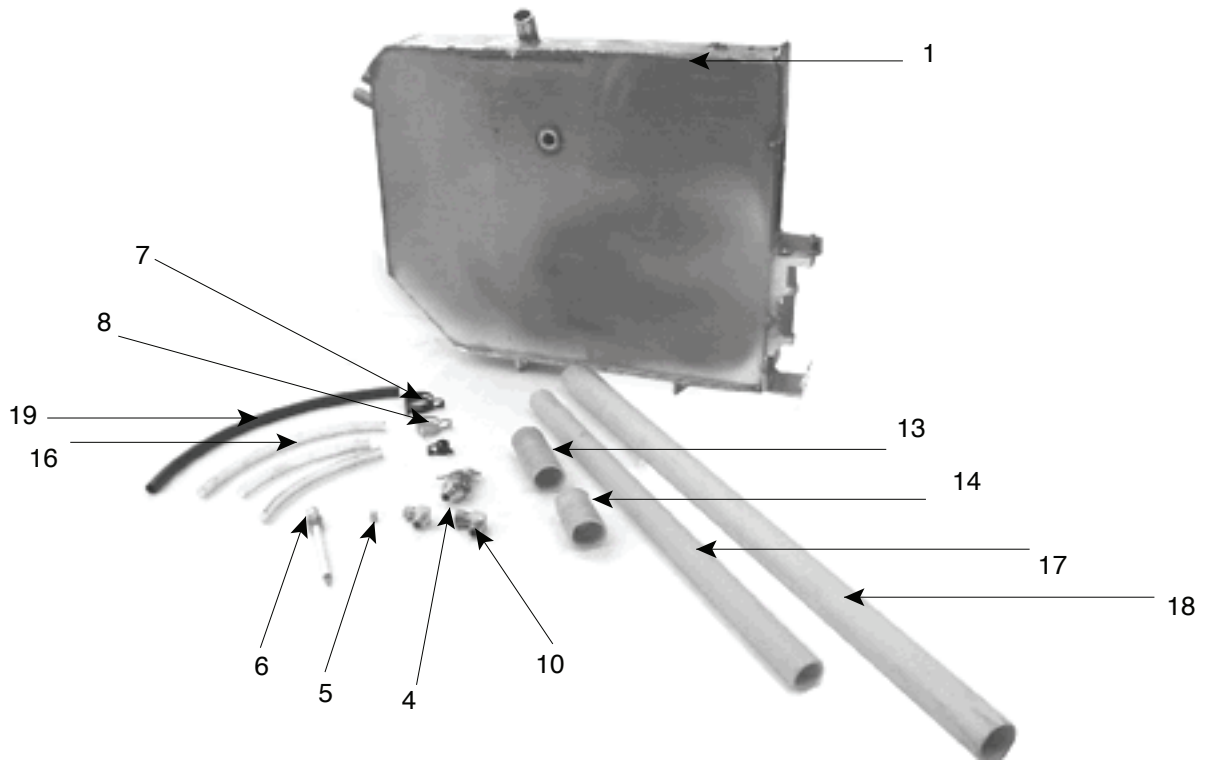

Key	Description	Part #
1	Steam Generator Weldment	141619
x	Right Steam Gen. Insulation*	096896
x	Left Steam Gen. Insulation*	096770
4	Safety Valve	106392
5	Drain Box Spray Nozzle	081670
6	Water Level Probe Right	141285
	Water Level Probe Left	141424
7	2¼" Hose Clamp	073259
8	1d" Hose Clamp	010873
x	¼" Hose Clamp	095656
10	d" Elbow with Fitting	057217
x	Top Cavity Drain Hose	141490

Key	Description	Part #
x	Bottom Cavity Drain Hose	141491
13	3" Bottom Steam Hose	099954
14	2" Bottom Steam Hose	099955
x	Sink Drain Hose	099915
16	Water Inlet Hose	096772
17	Inner Stm. Generator Hose	141467
18	Outer Stm. Generator Hose	141466
19	Condensate Hose	141463
x	Inlet Elbow	100924

* - Part Not Shown

x - Part Not Required

Parts List
Steamer -Individual Parts

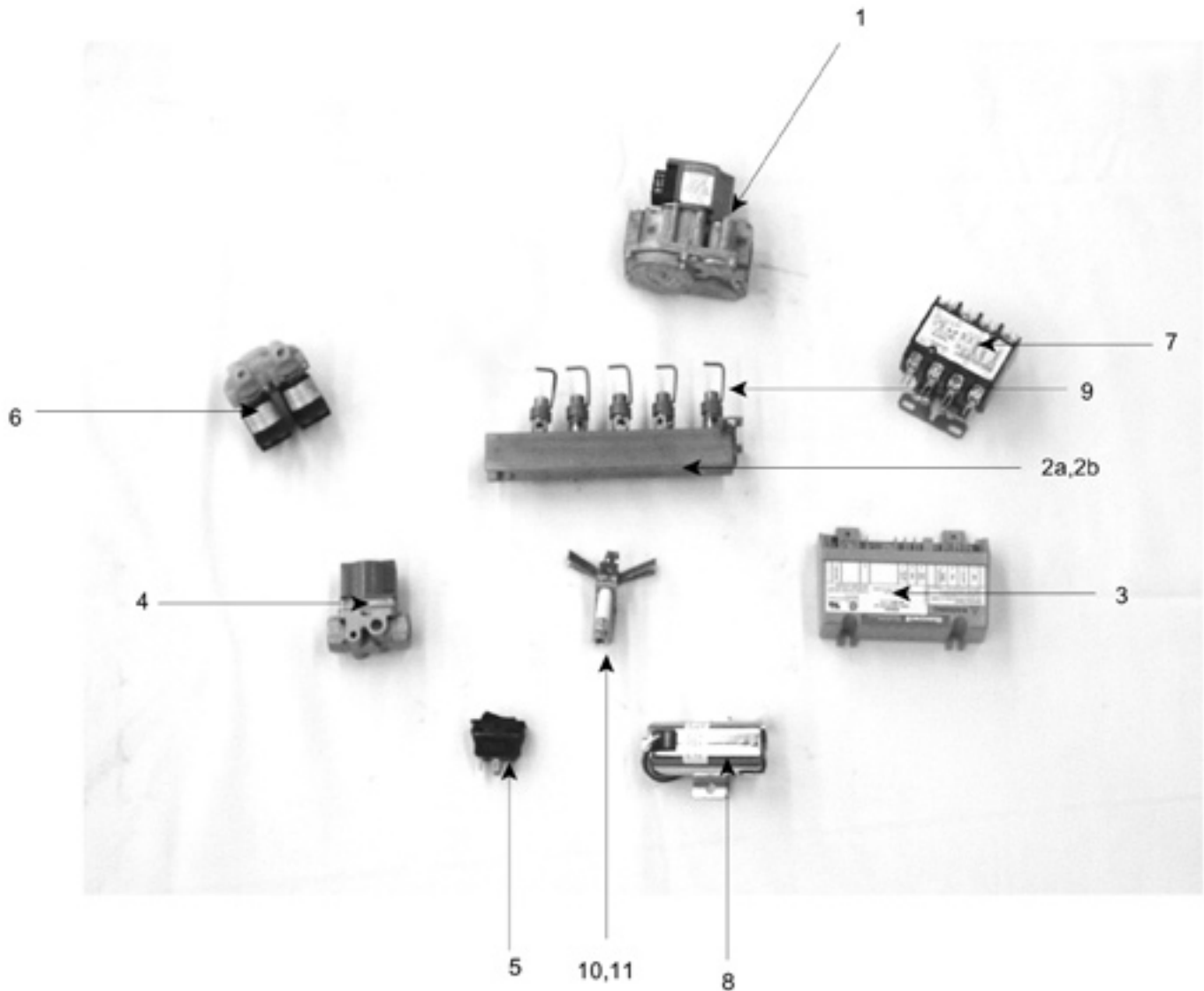

Key	Description	Part #
1	Main Gas Valve	099988
2a	Gas Manifold (Left)	141341
2b	Gas Manifold (Right)	141341
3	Igniter Module	085153
4	Solenoid Gas Valve	099906
5	Pilot Gas Switch	087951
6	Water inlet mounting for two outlet spill water	071235

Key	Description	Part #
7	Control Transformer	094164
8	Stm. Generator Drain Valve	074594
9	High Heat Flame Holder	013489
10	Pilot Burner - Natural Gas	096705
11	Pilot Burner - Propane Gas	096706
x	3 AMP Fuse	094156
x	Single water valve	100934

Electrical Schematic

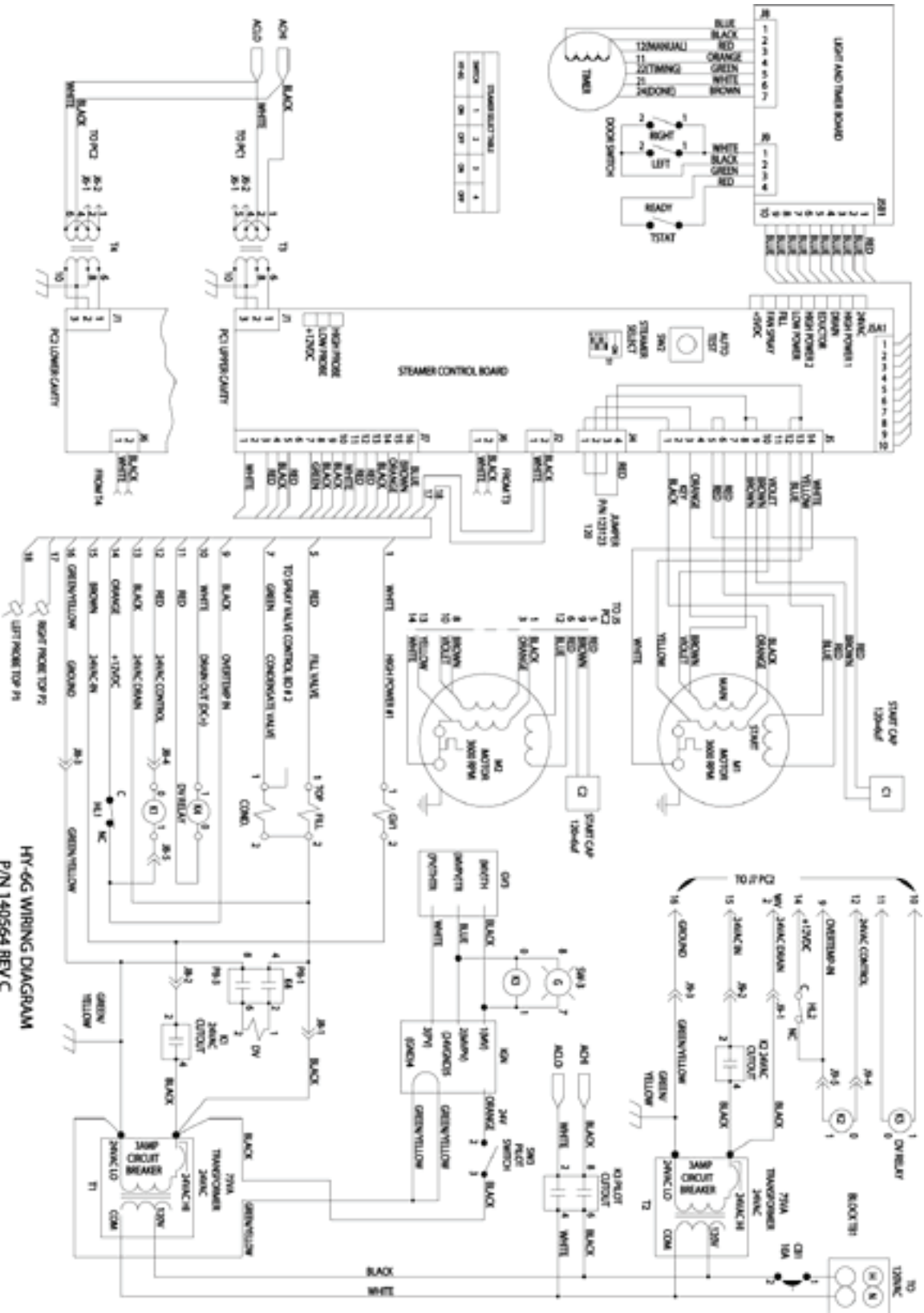

HY-6G WIRING DIAGRAM
P/N 140564 REV C

References

AMERICAN GAS ASSOCIATION LABORATORIES
8501 East Pleasant Valley Road
Cleveland, Ohio

AMERICAN NATIONAL STANDARDS INSTITUT1403
Broadway
New York, NY 10018

Z21.30 **Installation of Gas Appliances &
Piping**
Z223.1-1984 **National Fuel Gas Code**

NATIONAL SANITATION FOUNDATION
3475 Plymouth Road
Ann Arbor, Michigan 48106

NATIONAL FIRE PROTECTION ASSOCIATION
60 Battery March Park
Quincy, Massachusetts 02269

NFPA/54 **Installation of Gas Appliances &
Piping**
NFPA/70 **The National Electrical Code**

ZEP MANUFACTURING CO
1310-T Seaboard Industrial Blvd.
Atlanta, Georgia 30318

OM-HY-6G

Service Log

Model No. _____

Serial No. _____

Date Purchased _____

Purchase Order No. _____

Purchased From _____

Location _____

Date Installed _____

For Service Call _____

Date	Maintenance Performed	Performed by

LIMITED WARRANTY TO COMMERCIAL PURCHASERS*

(U.S. and Canadian Sales Only)

Groen Foodservice Equipment ("Groen Equipment") has been skillfully manufactured, carefully inspected, and packaged to meet rigid standards of excellence. Groen warrants its Equipment to be free from defects in material and workmanship for (12) twelve months with the following conditions and subject to the following limitations.

- I. This parts and labor warranty is limited to Groen Equipment sold to the original commercial purchaser/users (but not original equipment manufacturers {O.E.M.}), at its original place of installation in the continental United States, Hawaii and Canada.
- II. Damage during shipment is to be reported to the carrier, is not covered under this warranty, and is the sole responsibility of the purchaser/user.
- III. Groen, or an authorized service representative, will repair or replace, at Groen's sole election, any Groen equipment, including but not limited to, drawoff valves, safety valves, gas and electric components, found to be defective during the warranty period. As to warranty service in the territory described above, Groen will absorb labor and portal to portal transportation costs (time and mileage) for the first twelve (12) months from date of installation or fifteen (15) months from date of shipment from Groen.
- IV. This warranty does not cover boiler maintenance, calibration, periodic adjustments as specified in operating instructions or manuals, and consumable parts such as scraper blades, gaskets, packing, etc., or labor costs incurred for removal of adjacent equipment or objects to gain access to Groen Equipment. This warranty does not cover defects caused by improper installation, abuse, careless operation, or improper maintenance of equipment. This warranty does not cover damage caused by poor water quality or improper boiler maintenance.
- V. **THIS WARRANTY IS EXCLUSIVE AND IS IN LIEU OF ALL OTHER WARRANTIES, EXPRESS OR IMPLIED, INCLUDING ANY IMPLIED WARRANTY OF MERCHANTABILITY OR FITNESS FOR A PARTICULAR PURPOSE, EACH OF WHICH IS HEREBY EXPRESSLY DISCLAIMED. THE REMEDIES DESCRIBED ABOVE ARE EXCLUSIVE AND IN NO EVENT SHALL GROEN BE LIABLE FOR SPECIAL, CONSEQUENTIAL OR INCIDENTAL DAMAGES FOR THE BREACH OR DELAY IN PERFORMANCE OF THIS WARRANTY.**
- VI. Groen Equipment is for commercial use only. If sold as a component of another (O.E.M.) Manufacturer's equipment, or if used as a consumer product, such Equipment is sold AS IS and without any warranty.

***(Covers all Foodservice Equipment Ordered after October 1, 1995)**

NOTES



1055 Mendell Davis Drive
Jackson MS 39272
Telephone 601 372-3903
FAX 601 373-9587
www.groen.com

OM-HY-6G
Part Number 141601 Rev. B