

Operation Manual, Parts Directory and Price List

Glas tender®

VERTICAL DOOR COOLERS

SELF-CONTAINED MODELS - BB24, BB36, BB60, BB84, BB108, ND52, ND72, ND92, FV24, FV48, LP60, LP84, LP108, PT60, PT84, PT108, KC24, KC48, KC52, KC72, KC84

REMOTE MODELS - BB24, BB48, BB72, BB96, LP48, LP72, LP96, PT48, PT72, PT96

DRY STORAGE MODELS - DS24, DS48, DS72, LPDS24



BB60-L1-XSH(LR)



FV24-BS(L)



BB72-R1-BLN(LLR)
shown with optional wood panel doors



PT60-L1-LLH(LR/RL)

Glastender, Inc. · 5400 North Michigan Road · Saginaw, MI · 48604-9780
800.748.0423 · 989.752.4275 · Fax 800.838.0888 / 989.752.4444 · www.glastender.com

SERVICE AND PARTS

Terms and Conditions..... 1
 BB & ND Cooler Serial Number Information..... 1
 Warranty 2

INSTALLATION

Introduction 3
 Utility Requirements and Connections 3
 Uncrating and Start-Up Instructions 3
 Operation 3
 Cleaning Instructions..... 3 - 4
 Floor Sealing Instructions 4
 BB24 Minimum Air Flow Clearance Diagram..... 4
 Cooler Installation Checklist..... 5
 Cooler Design Change 6

SPECIFICATIONS

Electrical and Refrigeration Specifications..... 7
 Wiring Diagrams 8-12
 Endwall Models 8
 Self-Contained Models 9
 Remote Models 10
 Remote Models with Solenoid Control 11
 Built-in Fluorescent Light Fixtures 11
 BB24 Self-contained and KC24 Models 12

REPLACEMENT PARTS

Compressor and Condenser Related Parts 13-20
 BB24 Self-Contained & KC24..... 13
 BB36 14
 LP60, LP84, LP108, and Non Endwall BB60, BB84, BB108,
 ND52, ND72, ND92, KC72, and KC84..... 15
 BB36, BB60, ND52, and KC52 Endwall..... 16
 BB84, BB108, ND72, ND92, KC72, and KC84 Endwall 17
 KC48 18
 PT60, PT84, PT108 19
 FV24 and FV48 20
 Evaporator and Related Parts 21-23
 Doors and Related Parts 24-27
 Shelving, Racks and Related Parts 28
 Refrigeration Compartment Covers 29
 220 Volt Electrical Parts 30-31



TERMS AND CONDITIONS

PRICES:

All prices are LIST. Applicable taxes will be added.

QUOTATIONS:

Unless otherwise stated, quotations are effective for 30 days only.

ACCEPTANCE:

All orders are subject to acceptance by Glastender, Inc.'s headquarters in Saginaw, Michigan. Possession of the Product Directory and Price List is not an offer to sell.

SHIPMENTS:

F.O.B. factory in Saginaw, Michigan. Freight terms are Third Party or Collect if shipped directly to you. Prepay and Add to Invoice freight terms are available upon request. The approximate shipping weights of all products are listed with the prices. Partial shipments will be made unless otherwise specified by the customer. Surface freight classifications are:

- Glasswashers, Line Chillers - Class 92.5
- Cocktail Stations, Underbar Equipment - Class 85
- Bar Die/Underbar Equipment - Class 125
- Refrigeration Equipment, 48" long or smaller - Class 100
- Refrigeration Equipment, greater than 48" long - Class 110

All small items are evaluated to see the most cost effective means for shipment. Many small items ship via UPS or FedEx; however, when dimensional weight is excessive DB Schenker, UPS Supply Chain, or even common LTL carriers are the most cost effective choice. Spare parts orders received before 1:00 PM EST can usually be shipped the same day.

The order department is happy to assist with routing or shipping questions.

PAYMENT TERMS:

Cash should be included with all orders unless credit terms have been arranged. To establish credit, banking and trade references are required. A convenient credit application is available upon request. Payment via credit card is not our normal means of receiving payment. Visa and MasterCard will be accepted, but must be charged at the time of shipment. In addition, a payment via credit card for orders totaling more than \$500 will incur a 3% convenience fee on the total transaction amount.

DELIVERY:

The majority of equipment is manufactured to order and typically ships within three to six weeks after complete order information is received by the factory. In-stock equipment typically ships within two to three days of the factory receiving complete order information.

RETURNS:

Items specified as "Manufactured to Order" are NOT returnable.

A Return Material Authorization (RMA) number must be issued by the factory in advance for any items that are returnable. The RMA number MUST be noted on the outside of the returned package. Returns must be received within 90 days of the RMA issue date. Shipping charges must be prepaid. A minimum 20% restocking charge will be applied to all authorized returns if received in new, unused condition in the original packaging.

The above conditions apply to spare part returns, except spare part returns must be received within 30 days of original shipment for electronic or electrical parts or within 90 days for all other parts.

LOSS OR DAMAGE:

For customer routed shipments, Glastender, Inc. is not responsible for any loss, damage, or delay of merchandise during shipment. Such transit claims must be filed with the carrier. Merchandise must be examined on arrival. If shortages occur, Glastender, Inc. must be notified in writing within five (5) days of delivery to honor any shortage claim. Glastender will assume responsibility for freight claims on Prepay and Add shipments but the customer must inspect freight and note any damage upon receipt. Failure to do so may result in losses at the customer's expense.

CUSTOM ORDERS:

Custom orders must be paid in advance and are not subject to cancellation.

LAMINATES:

Some products include common, readily available plastic laminates of the customer's selection. There may be an additional charge if uncommon varieties are ordered.

05/18/10

BB & ND COOLER SERIAL NUMBER INFORMATION

This manual is specific to self-contained BB60, BB84, BB108, ND52, ND72, and ND92 coolers prior to the serial numbers and dates listed below.

BB60R	134121363F	02/26/09	ND52R	134121519F	03/09/09
BB60L	134121425F	03/03/09	ND52L	134121559F	03/11/09
BB84R	134121457F	03/04/09	ND72R	134121906F	04/08/09
BB84L	134121456F	03/04/09	ND72L	134121475F	03/11/09
BB108R	134121452F	03/04/09	ND92R	134121126F	02/09/09
BB108L	134121226F	02/17/09	ND92L	134122745F	06/10/09

WARRANTY STATEMENT



APPLICABLE TO ALL PRODUCTS SOLD WITHIN THE UNITED STATES AND CANADA

LABOR: Glastender, Inc. warrants all products to be free of defects in material and workmanship. In established areas, a start-up and a 90-day labor warranty are included with glasswasher models GT-24 and GT-30. The GT-18 series glasswashers include a 90-day labor warranty. Self-contained refrigeration models, except beer line chillers, include a 1-year labor warranty, for the duration of one year from date of installation or up to 18 months from date of factory shipment, whichever occurs sooner. For warranty labor claims beyond 15 months from the date of factory shipment, proof of date of installation or occupancy must be provided. Authorization for labor must be obtained from Glastender within the warranty period and prior to the service being performed. Labor warranty applies to the United States and Canada only.

PARTS: Within one year from date of installation or 18 months from date of factory shipment, whichever occurs sooner, Glastender, Inc. will replace any part or assembly found defective under normal use and service. Field replacement parts include a warranty of 90 days from date of installation.

FOUR YEAR ADDITIONAL COMPRESSOR WARRANTY: Glastender will warrant to the original user the compressor for all self-contained refrigeration models for an additional four years following the regular one-year warranty period. This plan applies to the compressor only.

A warranty claim form **MUST** accompany all returned defective parts or assemblies. This form **MUST** be completed in full. Failure to do so may result in delay or denial of credit. Any defective part or assembly must be returned to Glastender, Inc., Saginaw, Michigan, with all transportation and delivery charges prepaid. Warranty repairs or replacements will be shipped FOB factory in Saginaw, Michigan. Reimbursement for applicable freight charges covers ground service only.

Glastender provides in-warranty repairs during a service company's regular working days and hours. There is no provision for payment of a premium rate during "overtime" hours. When warranty service is requested during other than normal working hours, the end user will be charged the premium portion of the overtime rate.

The warranty does not cover equipment subjected to accidents, freight damage, alterations from the original design, improper power and/or plumbing hookups, improper chemical use, general misuse, or lack of routine required maintenance as determined by Glastender, Inc. Installation, normal control adjustments, general maintenance, correcting an installation error, or service calls that reveal the unit is functioning normally will not be reimbursed under warranty.

Condenser coils on self-contained refrigeration products must be cleaned regularly. Failure to provide adequate air flow to a refrigeration unit will void the warranty.

Glastender shall not be liable for loss of use, revenue, or profit, or for any other indirect, incidental, special, or consequential damage including, but not limited to, product spoilage or loss.

This warranty is conditioned upon Glastender receiving notice of any defect subject to this warranty within sixty (60) days of its discovery by the end user or dealer. All products are warranted only for the initial place of installation. Removal of a product automatically terminates this warranty.

SECOND YEAR EXTENDED PARTS & LABOR WARRANTY:

Glastender's one-year parts and labor warranty on self-contained refrigeration units, excluding beer line chillers, can be extended to two years with the purchase of a two year parts and labor warranty. Specify part number EWR2 (\$150 net price) when ordering.

EXPORT WARRANTY - One year parts only.

EXCLUSION OF WARRANTIES

EXCEPT AS PROVIDED ABOVE, GLASTENDER MAKES NO WARRANTIES, EXPRESS OR IMPLIED, INCLUDING, BUT NOT LIMITED TO, ANY IMPLIED WARRANTY OF MERCHANTABILITY, FITNESS FOR A PARTICULAR PURPOSE OR NON-INFRINGEMENT.

LIMITATION OF REMEDIES AND DAMAGES

If Buyer makes a valid and timely claim as outlined above, Glastender's liability and Buyer's remedies under this agreement will be limited solely to labor charges authorized and/or replacement or credit, at Glastender's option, with respect to Products returned at Buyer's expense within thirty (30) days after warranty repair. GLASTENDER'S LIABILITY WILL IN NO EVENT BE GREATER IN AMOUNT THAN THE PURCHASE PRICE OF THE RETURNED PRODUCTS. GLASTENDER WILL NOT BE LIABLE UNDER ANY CIRCUMSTANCE FOR CONSEQUENTIAL OR INCIDENTAL DAMAGES, INCLUDING, BUT NOT LIMITED TO, LABOR COSTS EXCEPT AS COVERED UNDER OUR WARRANTY, LOST PROFITS OR THE LOSS OF PERISHABLE PRODUCTS RESULTING FROM THE USE OF OR INABILITY TO USE OUR PRODUCTS OR FROM OUR PRODUCTS' INCORPORATION INTO OR BECOMING A COMPONENT OF ANY OTHER PRODUCT. NEITHER PARTY WILL HAVE ANY NEGLIGENCE OR OTHER TORT LIABILITY TO THE OTHER, OR TO ANY THIRD PARTY, ARISING FROM ANY BREACH OF THIS AGREEMENT.

GOVERNING LAW - JURISDICTION

The terms and conditions of an order are to be governed and construed according to the laws of the State of Michigan, without regard to conflict of laws principles. Buyer hereby consents to the jurisdiction and venue of the courts located in Saginaw County, Michigan.

No representative, distributor, dealer, or any other person is authorized to modify this warranty. This warranty replaces all other written or verbal warranties.

NOTE: Glastender, Inc.'s policy of constant quality improvement means that prices, specifications, and policies are subject to change without notice. Questions regarding this warranty should be directed to Glastender's Customer Service Representative.

03/03/10

IMPORTANT!!

Attention Refrigeration Service Companies

Please review the important warranty information on this page. If you believe a service call should be covered by the factory, please call the factory for authorization between 8AM and 5PM EST, Monday through Friday.

INTRODUCTION

This manual describes the operational features of Vertical Door Coolers. Please review this information before attempting installation and operation.

Long term, trouble-free service will follow if good housekeeping and maintenance procedures are followed. Thank you for selecting Glastender, Inc. products.

UTILITY REQUIREMENTS AND CONNECTIONS

- **Electrical:** 115 Volt AC, 1 Phase, 60 Hz. A separate 15 Amp circuit is recommended. A 6-foot grounded cord and plug is included with self-contained models.
- **Plumbing:** **Self-contained Models:** Automatic condensate evaporator is included. No drain connection required.
Remote Models: An external drain connection is required. Use the ten foot length of 1/2" ID by 5/8" OD plastic tubing provided to run the drain line for condensate. The tubing should exit through one of the 3/4" side knock-out holes.
Self-contained Keg Coolers: The drain pan drain is pre-plumbed at the factory to stub out below the compressor compartment. A field connection to an external drain must be made from that point.

UNCRATING AND START-UP INSTRUCTIONS

All models are shipped in one carton. These steps should be followed:

1. If legs or casters are included, bolt them to the base with the bolts provided.
2. Unwrap power cord from base if included.
3. Position unit and level and/or seal as required (see page 2 and 3).
4. The evaporator drain pan on remote models must be plumbed to an external drain. All units with draft beer must be plumbed to an external drain (except model KC24 which includes an internal plastic drain bottle). On self-contained models with draft beer and a factory installed finished top, the beer tower drain pan is plumbed through the cabinet and stubs out in the 3" space below the compressor compartment. Connection to an external drain must be made from that point.
5. Place shelves in desired location.
6. Plug into 115 volt AC outlet if a power cord is included. Remote models require electrical connections to be made by an electrician or remote refrigeration contractor.
7. Load with bottles or cans and allow time for products to cool.
8. Your Glastender equipment is now ready for use.

OPERATION

The operating temperature range is 36°F (2°C) to 40°F (5°C).

Self-contained models include an automatic defrost system. The refrigerator will defrost every six hours for approximately 20 minutes. Endwall coolers will defrost every four hours for approximately 15 minutes. During the defrost, the fan inside the cooler will remain on and the refrigeration system will turn off

CLEANING INSTRUCTIONS

Cleaning is essential to sustaining the integrity of your equipment and preventing corrosion.

ESTIMATED CLEANING TIME: 5 to 10 minutes per unit daily, 45 minutes quarterly

FREQUENCY: Daily cleaning of exterior & door gaskets. Quarterly cleaning of interior, including shelves.

Cleaning Instructions continued on page 4

Cleaning Instructions continued from page 3

PROCEDURE:

1. A non-chlorine based cleaner or mild detergent and warm water applied with a soft cloth or sponge to all contact surfaces.
2. Immediately rinse off cleaning agent(s), using clean warm water, clean soft cloth or sponge.
3. Dry with a soft clean cloth, removing standing water as soon as possible.

NOTES:

1. Never use hydrochloric acid, wire brushes, steel wool, scrapers, or chlorine based cleaners on stainless steel surfaces, since they will break down the passivity layer and allow corrosion to occur.
2. On stainless steel surfaces, you may use a soft bristle brush or Scotch-Brite® pad for more stubborn stains. Always scrub with the direction of the grain. Follow with a thorough cleaning as described above.
3. Deposits from food preparation must be properly removed. Even hard water deposits will rust stainless steel, if not removed.
4. Repeated cleaning may dry up black-vinyl-clad steel (exterior) surfaces of the cooler. Armor All® or similar product can bring back the shine. Apply the product to a cloth and then rub into the surface, rather than spraying it directly onto the black-vinyl-clad surface.
5. The cooler door gaskets are most often overlooked when cleaning. Failure to clean them regularly will lead to premature failure, since alcohol and moisture build-up breaks down the gasket material.

SEALING VERTICAL DOOR COOLER TO FLOOR

To comply with NSF & health codes, the cooler base must be sealed to the floor using NSF listed sealant. Place a bead of sealant along outer edges of the base and remove excess with disposable towel. The floor sealing procedure does not apply to models that include legs or casters.

Side View of Cabinet

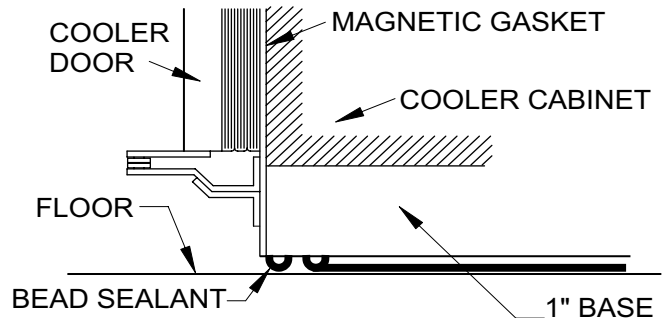

BB24 MINIMUM AIR FLOW CLEARANCE DIAGRAM

WARNING:
COMPRESSOR FAILURE DUE TO RESTRICTION OR BLOCKAGE OF AIR FLOW WILL VOID WARRANTY.

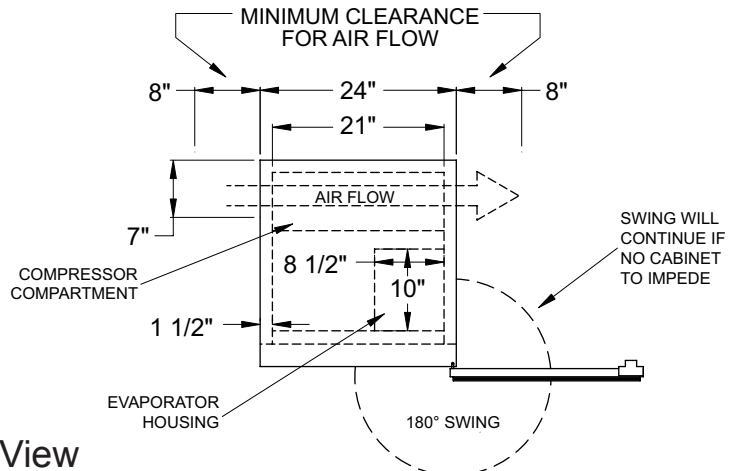

Plan View

ATTENTION INSTALLER: WARNING!!

Failure to level this cooler WILL VOID THE FACTORY WARRANTY. Doors will not close properly causing damage to hinges, handles, and/or gaskets which will adversely affect the refrigeration systems.

COOLER WITH 6" LEGS

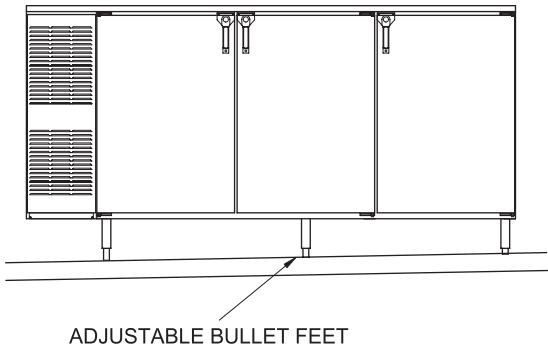

COOLER WITHOUT LEGS

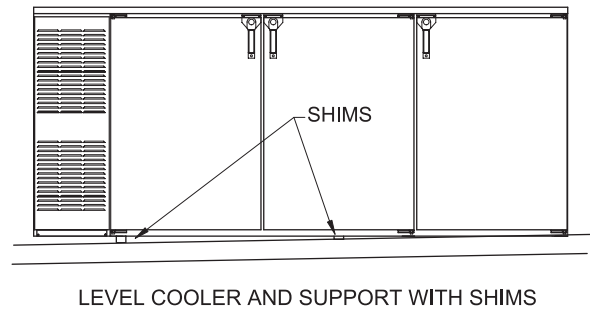

COOLER INSTALLATION CHECKLIST

- Is the unit evenly and solidly supported, either upon legs, or flat on the base; check for high spots?
- If the unit was designed for legs, are they attached?
- Is the unit level at the base, from end to end?
- Do the doors open and close freely, without touching any other part of the unit in travel?
- Are there open holes to the outside of the cabinet which are not plugged or insulated?
- Are there obstructions of any kind to air flow into or out of the condensing unit?
- Is product tubing or are other lines installed in such a manner to not allow shelf access?

SPECIAL INSTRUCTIONS FOR KEG COOLERS

Before you begin:

1. Disassemble the tower into three parts, stiffener, skin, and top plate, by unscrewing the top two screws.
2. Mount the column stiffener with the four 1/4"-20x1-1/4" bolts provided.
3. Install insulation provided into the bottom of the column stiffener.
4. Place the column skin over the stiffener. Run the beer lines through the hole at the same time.
5. Install insulation provided into the top of the tower assembly.
6. Mount the column top plate to the column stiffener with the two #10-32x1/2" phillips flat head s/s machine screws provided.
7. Apply a bead of silicone sealant around the perimeter of the column. Use your finger to smooth out the bead.
8. Wash tapping device and faucet with detergent and water. Flush beer tapping device and faucet lines.

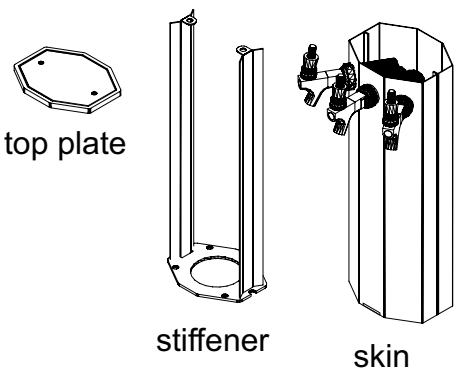

COOLER DESIGN CHANGE

IMPORTANT DESIGN CHANGE INFORMATION

In February 2004, Glastender released new BB and ND self contained cooler designs with the evaporator housing moved into an area above the compressor compartment. The serial numbers for these units will be 90000 and above. As of September 2006, KC52, KC72, and KC84 model keg coolers are being manufactured as endwall models. Due to special customer request some BB and ND self contained models may not have the endwall design. Please be sure to verify which cooler design type you are ordering parts for. The term endwall will be used throughout this document to denote parts used for coolers featuring this design.

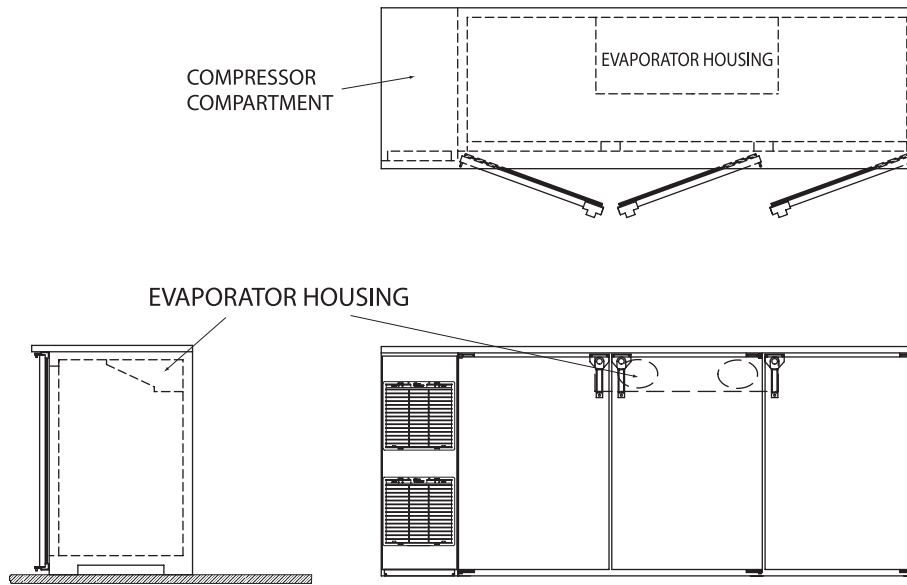

Standard cooler configuration with evaporator inside cooler area. Compressor compartment may be located left or right.

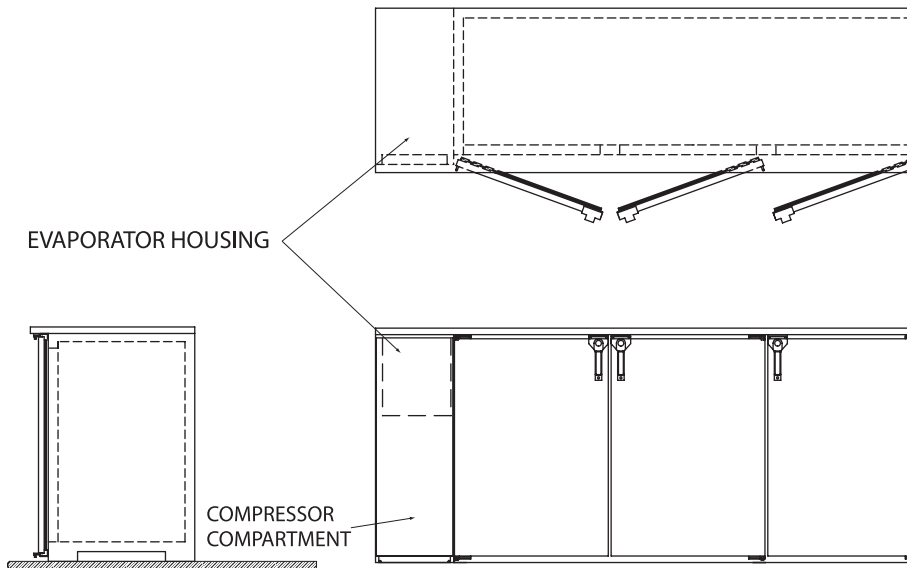

Endwall cooler configuration (most BB and ND models manufactured after Feb. 2004, most KC models manufactured after Sept. 2006) with evaporator located in housing above the compressor compartment. Compressor compartment may be located left or right.

BB24 SELF-CONTAINED & KC24 MANUFACTURED AFTER 4/14/06

<u>ELECTRICAL</u>	<u>REFRIGERANT</u>		<u>PRESSURE P.S.I.G.</u>	
	<u>TYPE</u>	<u>CHARGE</u>	<u>HIGH</u>	<u>LOW</u>
115V, 1 phase, 60 Hz 4.0 full load amps, 1/6 HP	R134a	5.0 oz.	200	85

KC24 MANUFACTURED BEFORE 4/14/06

<u>ELECTRICAL</u>	<u>REFRIGERANT</u>		<u>PRESSURE P.S.I.G.</u>	
	<u>TYPE</u>	<u>CHARGE</u>	<u>HIGH</u>	<u>LOW</u>
115V, 1 phase, 60 Hz 2.8 full load amps, 1/6 HP	R134a	5.0 oz.	200	85

FV24, FV48, AND BB36 SELF-CONTAINED MODELS MANUFACTURED BEFORE 2/04

<u>ELECTRICAL</u>	<u>REFRIGERANT</u>		<u>PRESSURE P.S.I.G.</u>	
	<u>TYPE</u>	<u>CHARGE</u>	<u>HIGH</u>	<u>LOW</u>
115V, 1 phase, 60 Hz 5.1 full load amps, 1/5 HP	R22	13.5 oz.	285	144

BB24 REMOTE, BB48, BB72, BB96, LP48, LP72, LP96, PT48, PT72, PT96

<u>ELECTRICAL</u>	<u>REFRIGERANT</u>		<u>PRESSURE P.S.I.G.</u>	
	<u>TYPE</u>	<u>CHARGE</u>	<u>HIGH</u>	<u>LOW</u>
115V, 1 phase, 60 Hz	R22	n/a	n/a	n/a

LP60, LP84, LP108 & NON-ENDWALL BB60, BB84, BB108, KC48, KC72, & KC84

<u>ELECTRICAL</u>	<u>REFRIGERANT</u>		<u>PRESSURE P.S.I.G.</u>	
	<u>TYPE</u>	<u>CHARGE</u>	<u>HIGH</u>	<u>LOW</u>
115V, 1 phase, 60 Hz 8.8 full load amps, 1/3 HP	R22	13.5 oz.	285	144

PT60, PT84

<u>ELECTRICAL</u>	<u>REFRIGERANT</u>		<u>PRESSURE P.S.I.G.</u>	
	<u>TYPE</u>	<u>CHARGE</u>	<u>HIGH</u>	<u>LOW</u>
115V, 1 phase, 60 Hz 8.8 full load amps, 1/3 HP	R404a	9.0 oz.	285	144

PT108

<u>ELECTRICAL</u>	<u>REFRIGERANT</u>		<u>PRESSURE P.S.I.G.</u>	
	<u>TYPE</u>	<u>CHARGE</u>	<u>HIGH</u>	<u>LOW</u>
115V, 1 phase, 60 Hz 8.8 full load amps, 1/3 HP	R404a	10.0 oz.	285	144

BB36, BB60, ND52, KC52 ENDWALL MODELS

<u>ELECTRICAL</u>	<u>REFRIGERANT</u>		<u>PRESSURE P.S.I.G.</u>	
	<u>TYPE</u>	<u>CHARGE</u>	<u>HIGH</u>	<u>LOW</u>
115V, 1 phase, 60 Hz 7.2 full load amps, 1/3 HP	R134a	*12.0 oz.	186	88

* 12.0 oz. charge Serial #134-106565-F and after. 20.0 oz. charge prior to Serial #134-106565-F.

BB84, BB108, ND72, ND92, KC72, KC84 ENDWALL MODELS

<u>ELECTRICAL</u>	<u>REFRIGERANT</u>		<u>PRESSURE P.S.I.G.</u>	
	<u>TYPE</u>	<u>CHARGE</u>	<u>HIGH</u>	<u>LOW</u>
115V, 1 phase, 60 Hz 10.1 full load amps, 1/3 HP	R404a	16.0 oz.	331	174

WIRING DIAGRAM FOR BB36, BB60, ND52, & KC52 ENDWALL MODELS

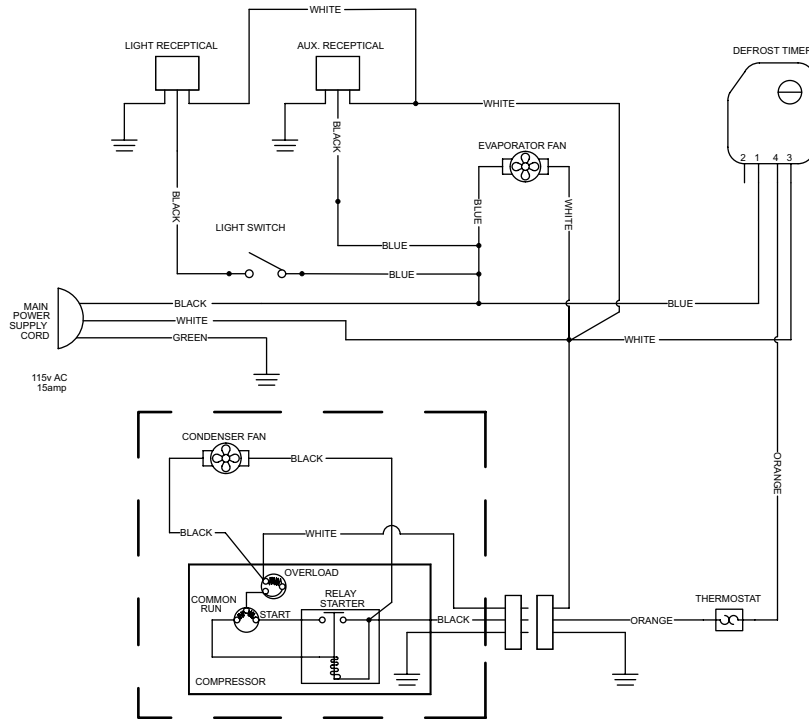

WIRING DIAGRAM FOR MODELS BB84, BB108, ND72, ND92, KC72, & KC84 ENDWALL MODELS

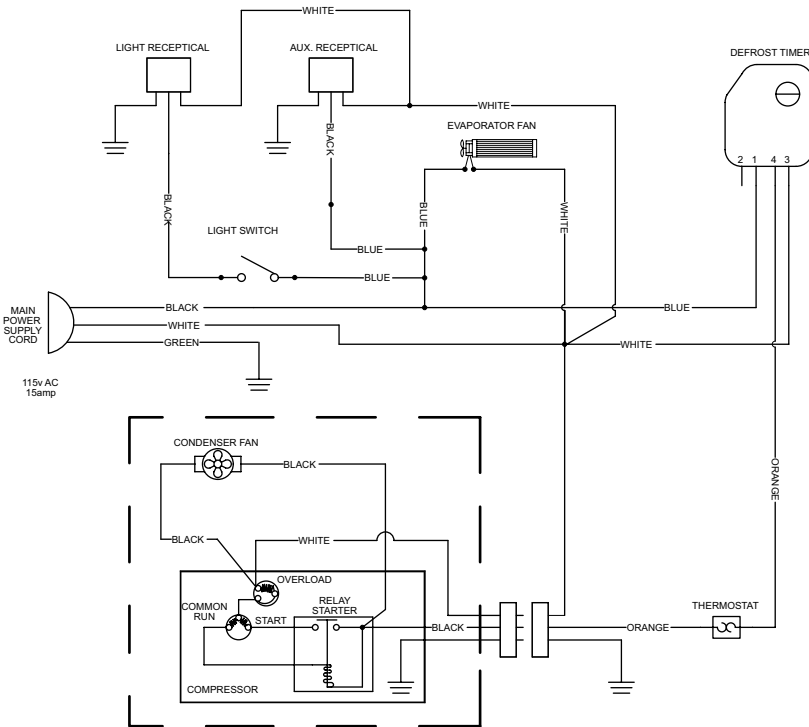

*NOTE: See page 7 for endwall BB, ND, and KC self-contained model wiring diagrams

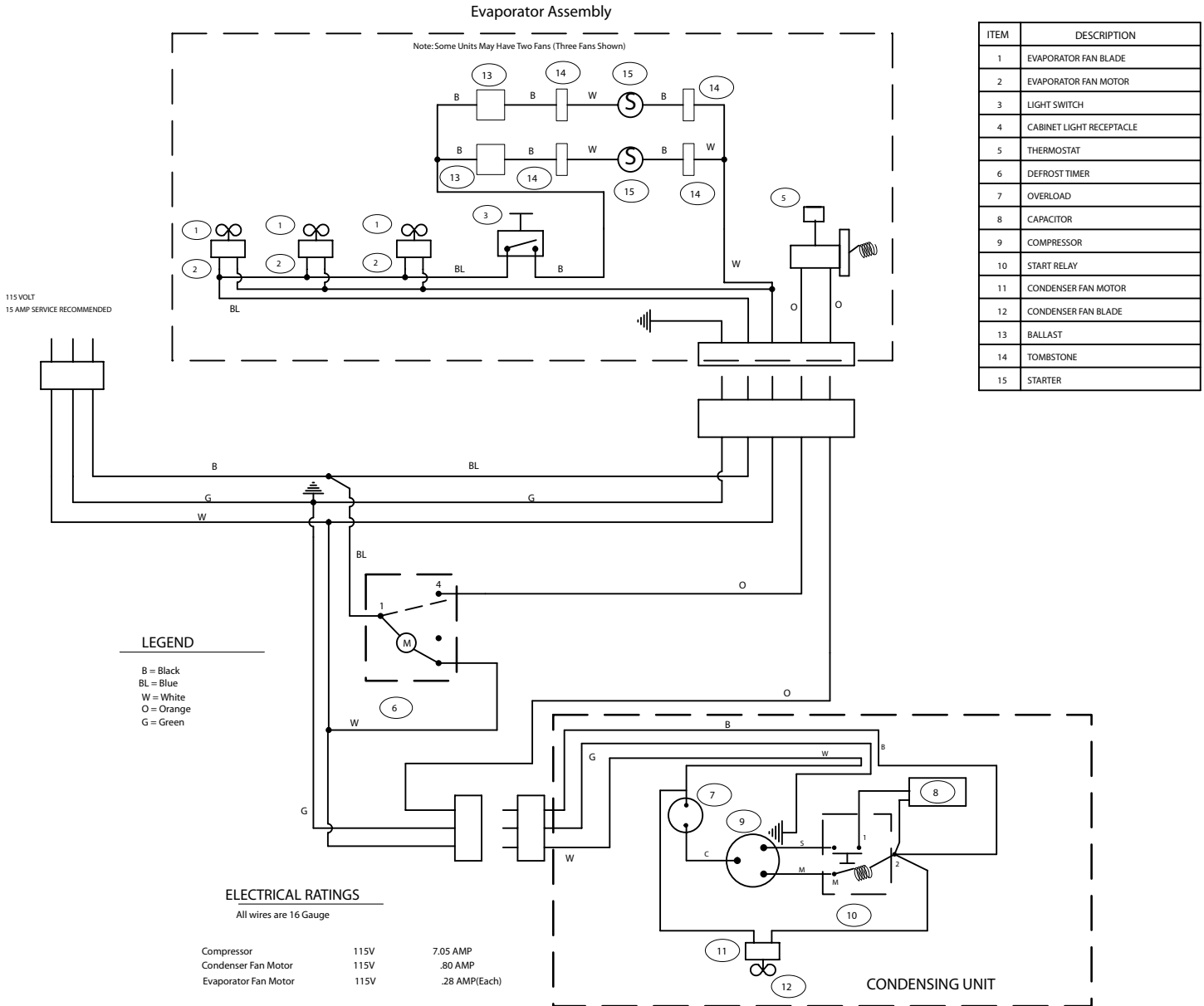

WIRING DIAGRAM FOR REMOTE COOLERS INCLUDING MODELS BB24, BB48, BB72, BB96, LP48, LP72, LP96, PT48, PT72, PT96

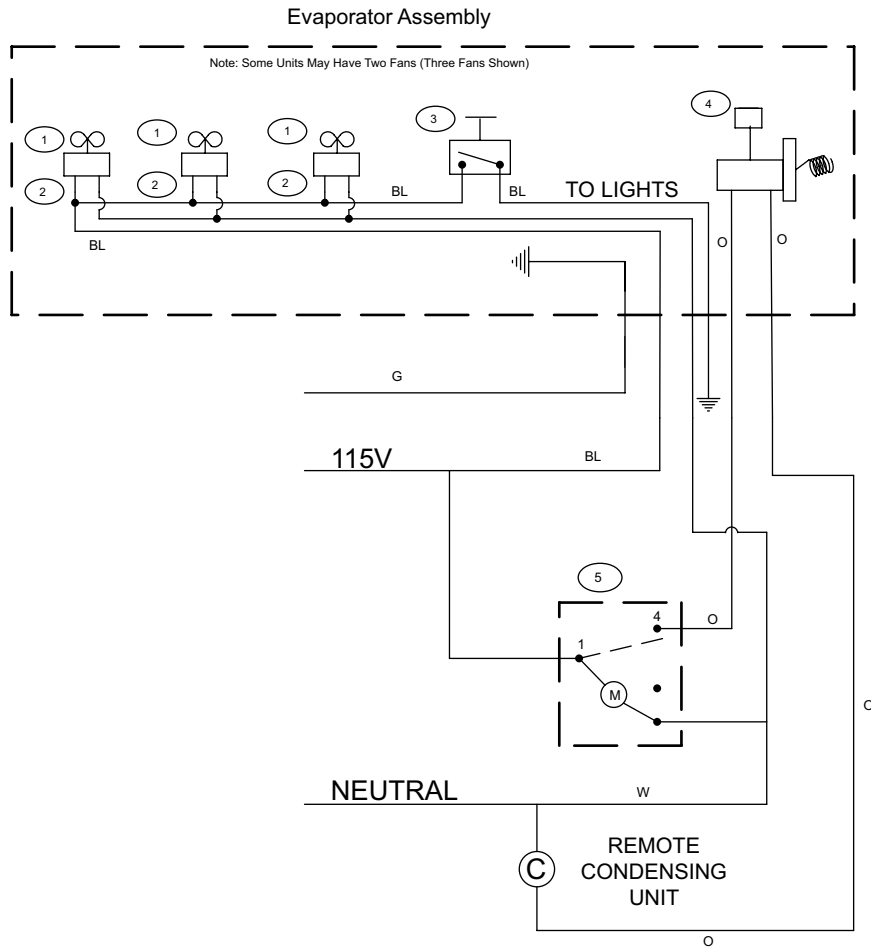

ITEM	DESCRIPTION
1	EVAPORATOR FAN BLADE
2	EVAPORATOR FAN MOTOR
3	LIGHT SWITCH
4	THERMOSTAT
5	DEFROST TIMER

LEGEND

BK = Black
 BL = Blue
 W = White
 O = Orange
 G = Green
 R = Red
 Y = Yellow
 Y/BL = Yellow w/blue stripe
 Y/R = Yellow w/red stripe

ELECTRICAL RATINGS

All wires are 16 Gauge

Evaporator Fan Motor	115V	.28 AMP(Each)
----------------------	------	---------------

**WIRING DIAGRAM FOR REMOTE COOLERS WITH SOLENOID FOR
INSTALLING MORE THAN ONE UNIT ON ONE CONDENSING UNIT**

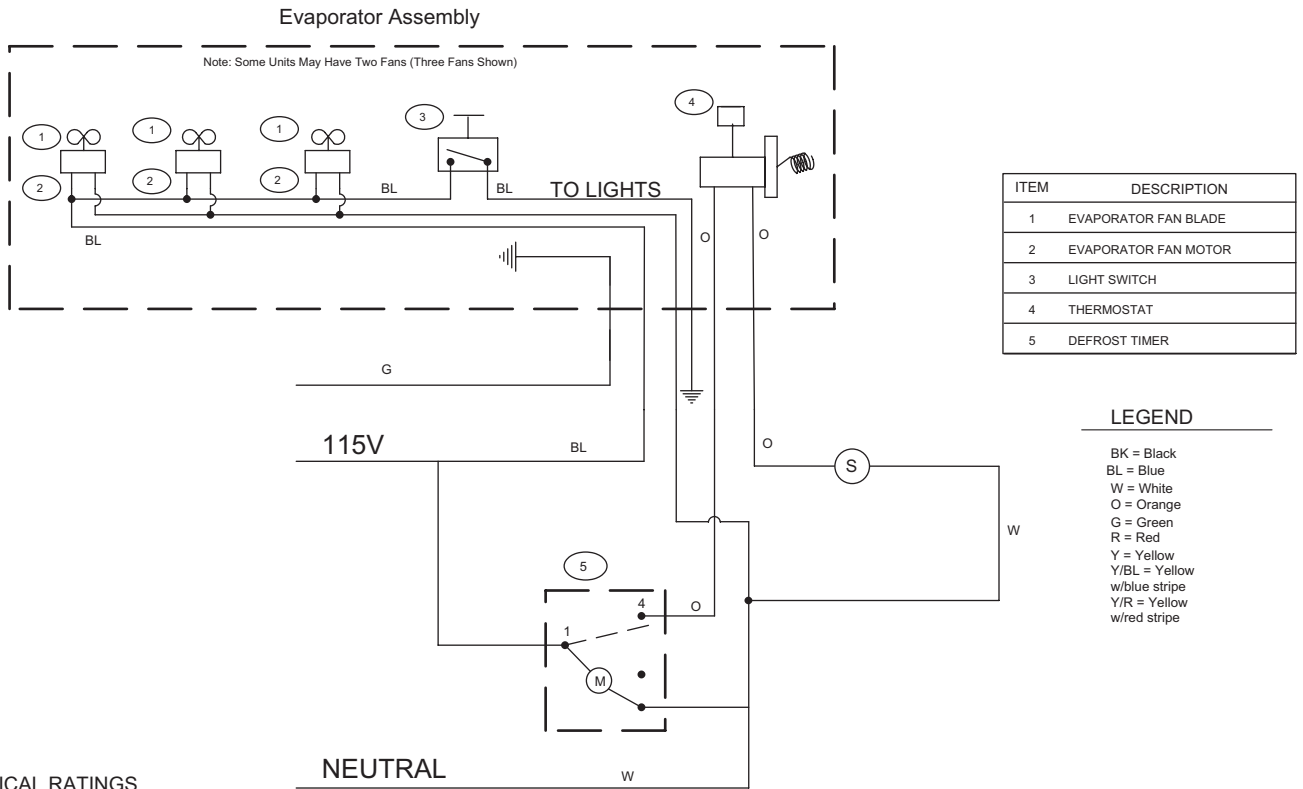

ELECTRICAL RATINGS
 All wires are 16 Gauge

Evaporator Fan Motor 115V .28 AMP(Each)

**WIRING DIAGRAM FOR MODELS AFTER 2/15/00
WITH FLOURESCENT LIGHT SYSTEM**

**FLOURESCENT LIGHT SYSTEM
TWO LIGHT**

**FLOURESCENT LIGHT SYSTEM
ONE LIGHT**

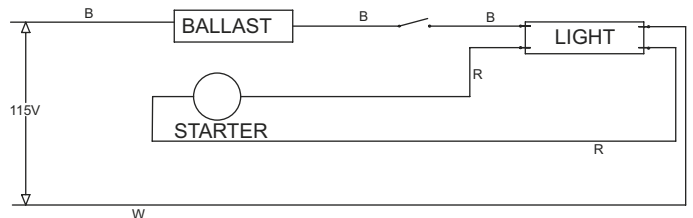
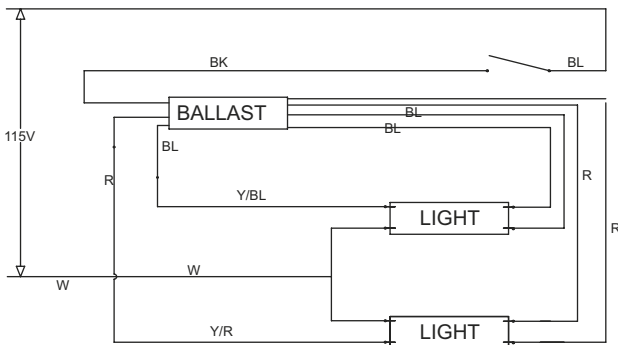

WIRING DIAGRAM FOR BB24 SELF-CONTAINED & KC24 AFTER 4/14/06

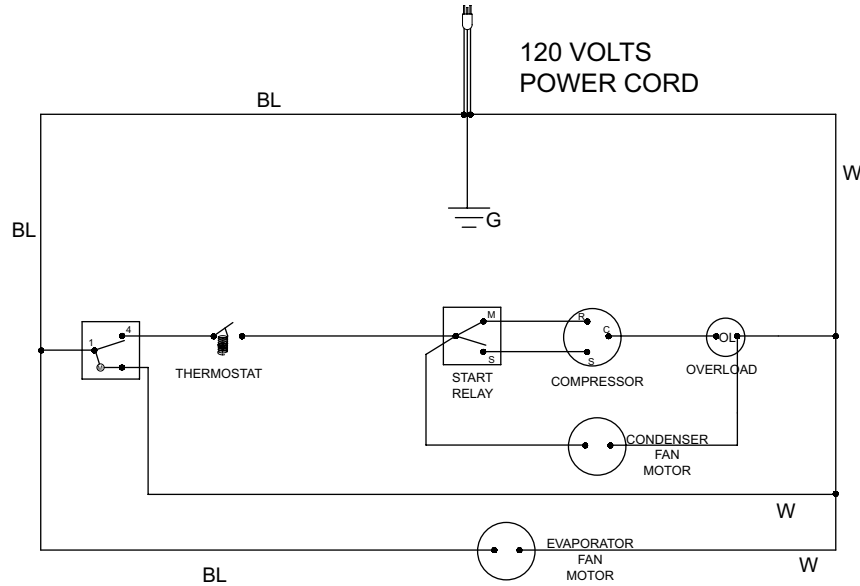

O = ORANGE
 W = WHITE
 G = GREEN
 BL = BLUE
 B = BLACK
 ALL WIRE 16GA.

ELECTRICAL RATINGS	
COMPRESSOR,	2.7 AMPS
CONDENSER FAN MOTOR	.2 AMPS
EVAPORATOR FAN MOTOR	.2 AMPS
TOTAL 3.1 AMPS	

KC24 BEFORE 4/14/06 WIRING DIAGRAM

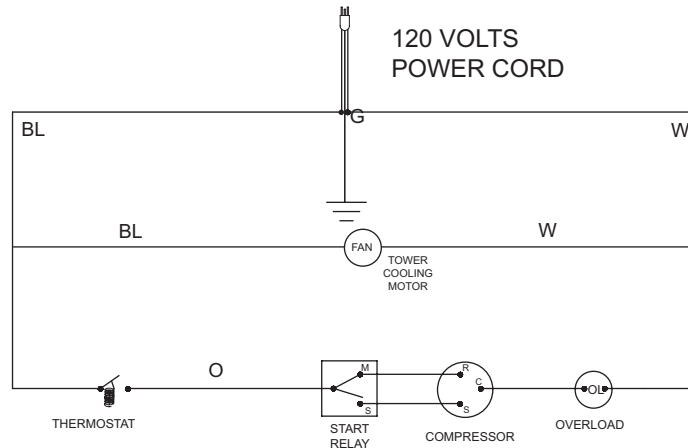

O = ORANGE
 W = WHITE
 G = GREEN
 BL = BLUE
 B = BLACK
 ALL WIRE 16GA.

ELECTRICAL RATINGS	
COMPRESSOR,	2.7 AMPS

<u>PART NO.</u>	<u>OLD PART NO.</u>	<u>DESCRIPTION</u>	<u>PRICE</u>
1. 06001435	GT-035006	1/6 HP Aspera compressor, R134a	\$390.00
2. 06001647	GT-034101	Relay for 1/6 HP Aspera R134a compressor	15.00
3. 06001341	GT-031200	Overload protector for 1/6 HP Aspera R134a compressor	15.00
4. 06001397	GT-033000	Automatic defrost timer	32.00
5. 06001694	GT-035131	Condenser fan motor	35.00
6. 09000298	GT-032804	Condenser fan motor blade	5.00
06001125	GT-032315	Beer tower cooling fan shroud (KC24 models 05/01 - 04/14/06)	17.00
06001452	GT-035128	Beer Tower Cooling Fan Motor (KC24 models 05/01 - 04/14/06)	65.00
06001396	GT-032809	Exterior blade assembly (KC24 models 05/01 - 04/14/06)	10.00
06001395	GT-032802	Interior blade assembly (KC24 models 05/01 - 04/14/06)	5.00
7. 07000133	GT-031513	Condenser fan motor mounting bracket	20.00
8. 04000100	GT-032608	Condenser coil (7" L, 6-7/8" H, 2-1/2" W)	130.00
06001389	GT-032611	Static condenser coil (KC24 before 04/14/06)	125.00
9. 06004028		Filter dryer with service port	25.00
10. 06000176	GT-038000	Condensate pan	42.00
11. 07000234		Wicking material	24.00
05000644		Wicking Material (KC24 before 04/14/06)	10.00
12. 04000124	GT-032509	Cap tube 96" X .036	20.00
13. 06001405	GT-033202	Thermostat with knob and plate [Selco]	50.00
14. 06001632	GT-038419	Knob only	3.00

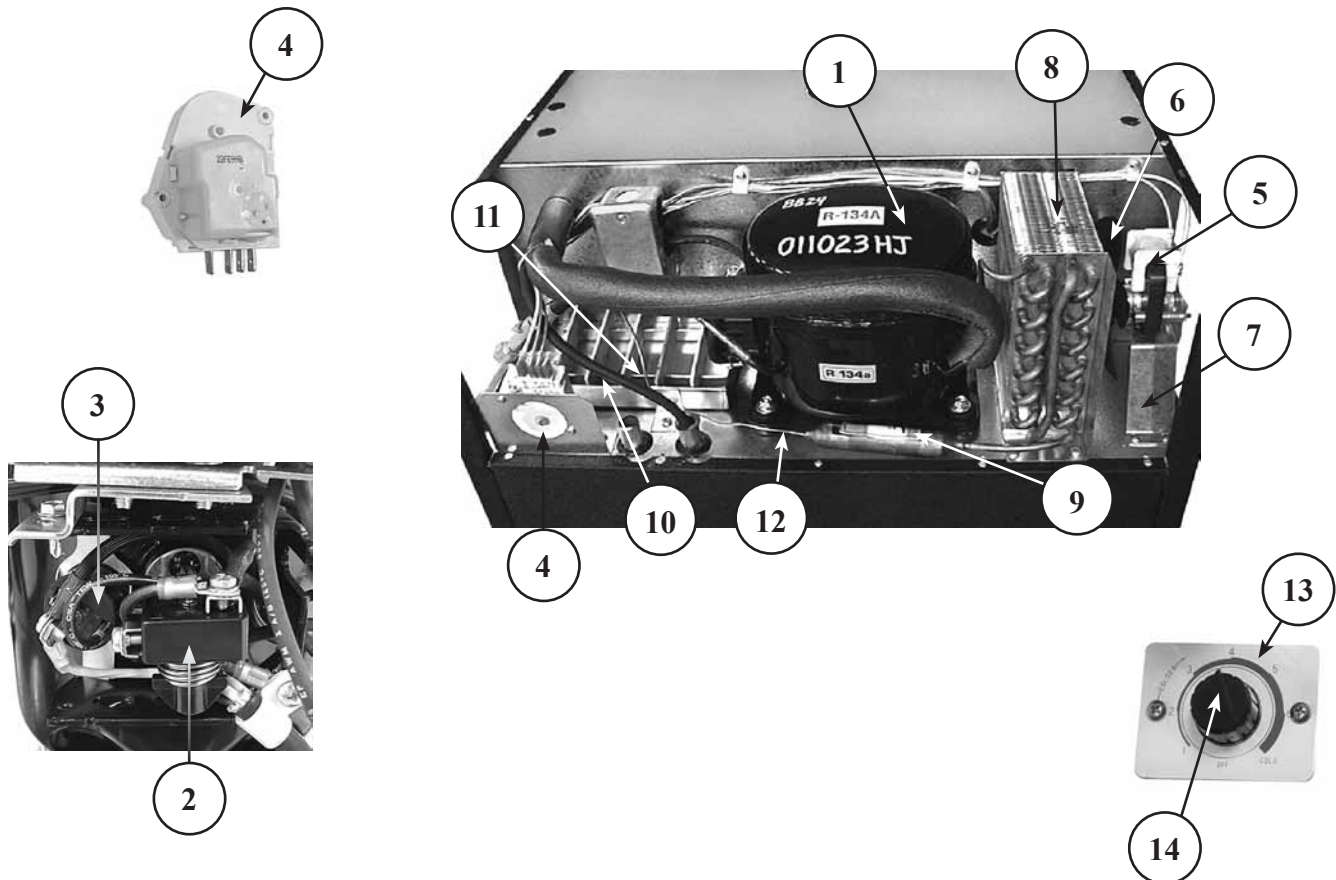

STANDARD BB36 COMPRESSOR AND CONDENSER RELATED PARTS



PART NO.	OLD PART NO.	DESCRIPTION	PRICE
1. 11000082	GT-035005	1/5 HP Aspera compressor, R22	\$535.00
2. 06001379	GT-032201	Start capacitor for 1/5 HP Aspera R22 compressor	20.00
3. 08000083	GT-034107	Relay for 1/5 HP Aspera R22 compressor	15.00
4. 08000069	GT-031204	Overload protector for 1/5 HP Aspera R22 compressor	15.00
06001444	GT-035027	1/5 HP Tecumseh compressor, R22 (after 4/00)	490.00
06001382	GT-032211	Start capacitor for 1/5 HP Tecumseh R22 compressor	15.00
06001415	GT-034117	Relay for 1/5 HP Tecumseh R22 compressor	19.00
06001303	GT-031212	Overload protector for 1/5 HP Tecumseh R22 compressor	10.00
5. 08000085	GT-035106	Condenser fan motor, 16W	110.00
6. 08000081	GT-032801	Condenser fan motor blade assembly	13.00
7. 06001321	GT-031515	Condenser fan motor mounting bracket	5.00
8. 08000076	GT-032601	Condenser coil (10"L x 7-15/16"W x 4"D)	220.00
9. 08000075	GT-032307	Fan shroud, condenser	11.00
10. 06004028		Filter dryer with service port	25.00
11. 06001648	GT-038001	Condensate pan (13-3/4"L x 9-1/2"W x 1"D)	58.00
12. 07000234	GT-038201	Wicking material (2 required)	24.00
13. 06001461		Elbow, white nylon, 1/2" x 1/2"	2.00
14. 06001345	GT-031716	Tubing, drain, clear plastic, 1/2" ID x 5/8" OD, per foot	1.45
15. 08000074	GT-031532	Base, condensing unit	30.00
16. 06001397	GT-033000	Automatic defrost timer, 6hr.	32.00
17. 06001313	GT-031400	Condensing unit power cord	20.00
11000120	GT-031717	Cap tube 60" X .036	20.00
18. 06001384	GT-032501	Accumulator, suction line	40.00

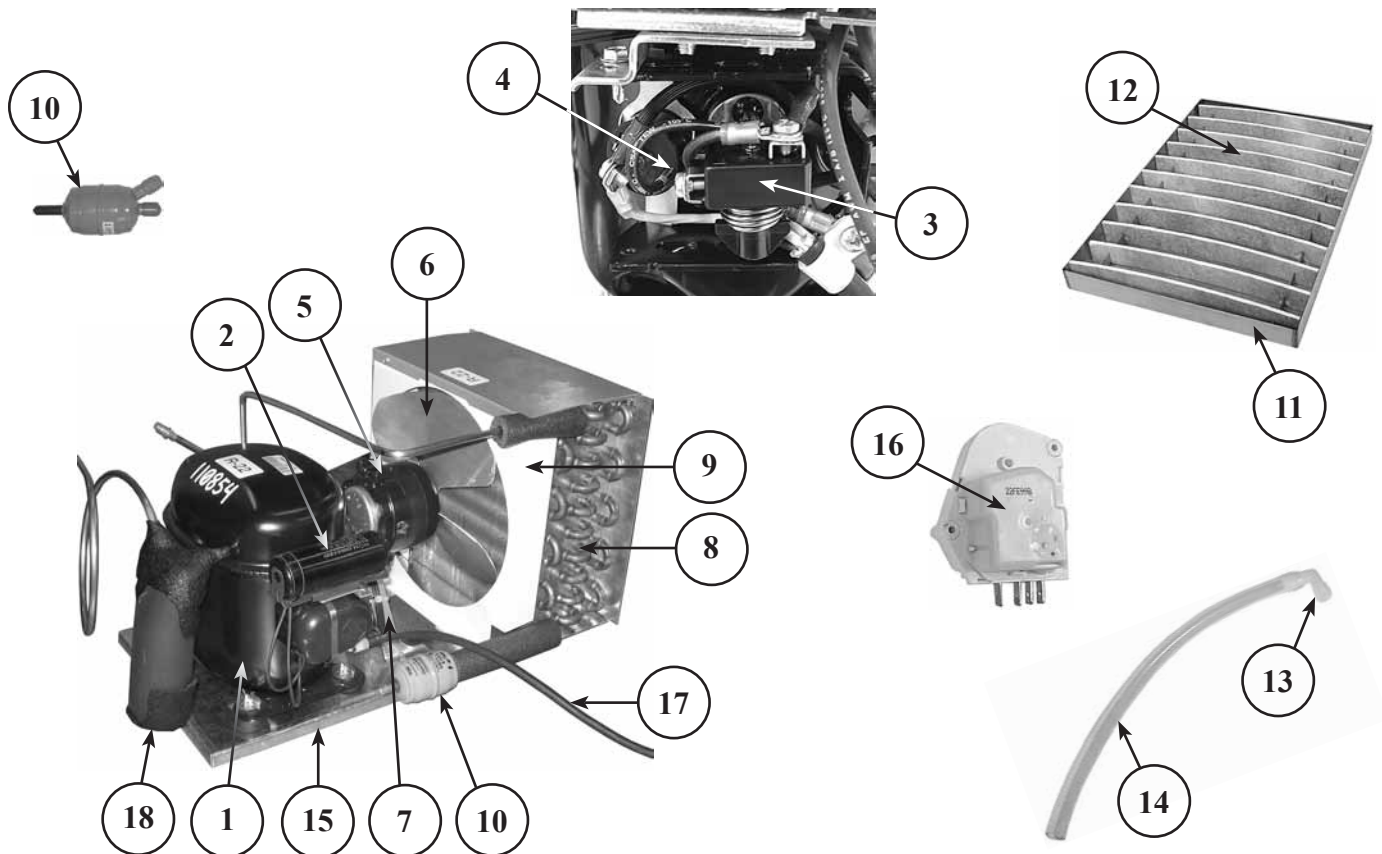

<u>PART NO.</u>	<u>OLD PART NO.</u>	<u>DESCRIPTION</u>	<u>PRICE</u>
1. 07000172	GT-035002	1/3 HP Aspera compressor, R22	\$500.00
2. 06001379	GT-032201	Start capacitor for 1/3 Aspera HP R22 compressor	20.00
3. 06001414	GT-034103	Relay for 1/3 HP Aspera R22 compressor	14.00
4. 08000068	GT-031202	Overload protector for 1/3 HP Aspera R22 compressor	12.00
06001443	GT-035025	1/3 HP Tecumseh compressor, R22 (after 2/00)	400.00
06001380	GT-032206	Start capacitor for 1/3 HP Tecumseh R22 compressor	20.00
07000168	GT-034112	Relay for 1/3 HP Tecumseh R22 compressor	18.00
07000128	GT-031207	Overload protector for 1/3 HP Tecumseh R22 compressor	12.00
5. 08000085	GT-035106	Condenser fan motor	110.00
6. 08000081	GT-032801	Condenser fan motor blade assembly	13.00
7. 06001321	GT-031515	Condenser fan motor mounting bracket	5.00
8. 08000076	GT-032601	Condenser coil (10"L x 7-15/16"W x 4"D)	220.00
9. 08000075	GT-032307	Fan shroud, condenser	11.00
10. 06004028		Filter dryer with service port	25.00
11. 06001648	GT-038001	Condensate pan (13-3/4"L x 9-1/2"W x 1"D)	58.00
12. 07000234	GT-038201	Wicking material (2 required)	24.00
13. 06001461		Elbow, white nylon, 1/2" x 1/2"	2.00
14. 06001345	GT-031716	Tubing, drain, clear plastic, 1/2" ID x 5/8" OD, per foot	1.45
15. 08000074	GT-031532	Base, condensing unit	30.00
16. 06001397	GT-033000	Automatic defrost timer, 6hr.	32.00
17. 06001313	GT-031400	Condensing unit power cord	20.00
06001614	GT-032510	Cap tube 110" X .054	20.00
18. 06001384	GT-032501	Accumulator, suction line	40.00

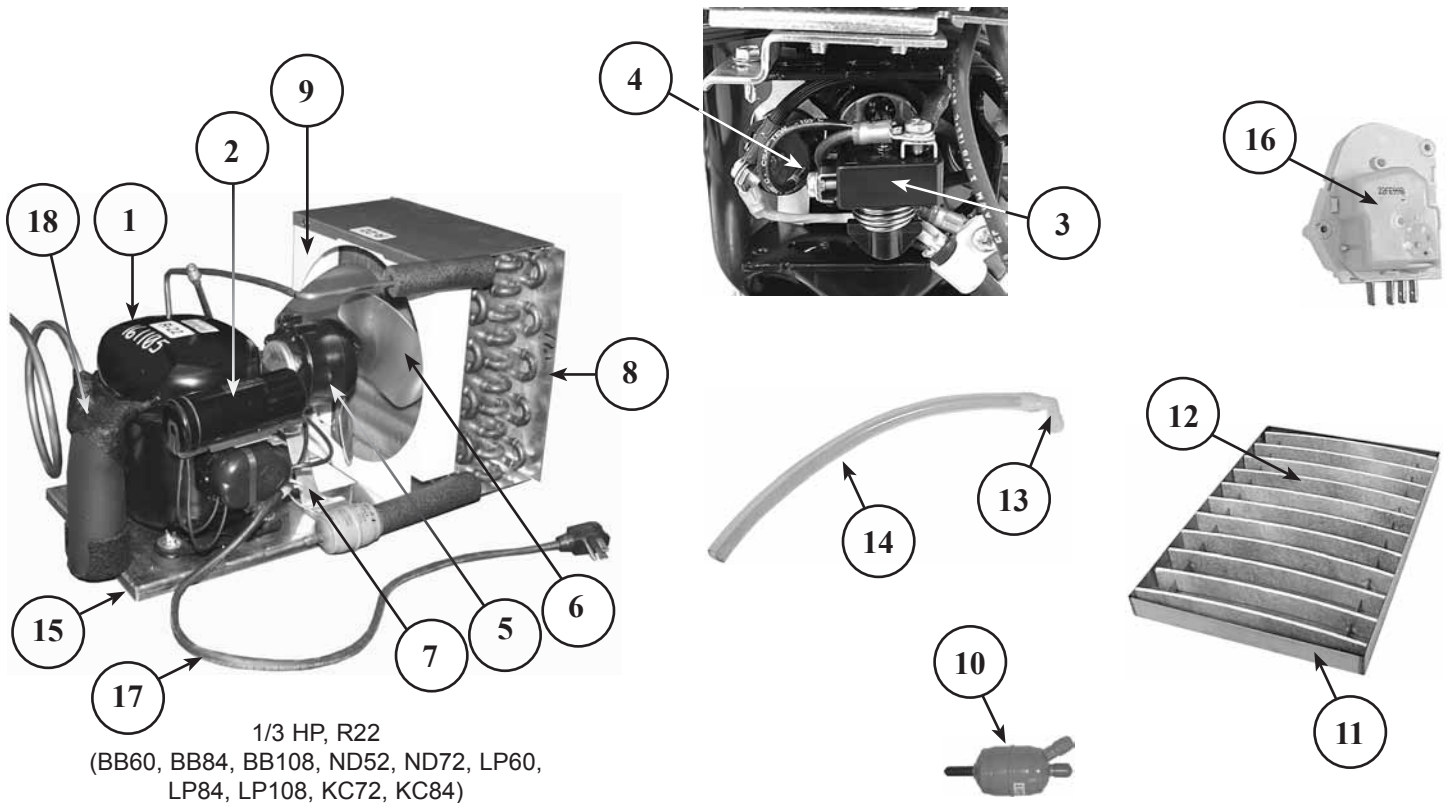

BB36, BB60, ND52, & KC52* COMPRESSOR AND CONDENSER RELATED PARTS FOR ENDWALL MODELS



PART NO.	OLD PART NO.	DESCRIPTION	PRICE
1. 06001439	GT-035014	1/3 HP Tecumseh compressor, R134a	\$435.00
2. 09000481	GT-032210	Start capacitor for 1/3 HP Tecumseh R134a compressor	10.00
3. 09000479	GT-034114	Relay for 1/3 HP Tecumseh R134a compressor	20.00
4. 09000480	GT-031211	Overload protector for 1/3 HP Tecumseh R134a compressor	11.50
5. 06001449	GT-035114	Condenser fan motor	95.00
6. 08000081	GT-032801	Condenser fan blade assembly	13.00
7. 06001319	GT-031512	Condenser fan motor mounting bracket	5.00
8. 08000076	GT-032601	Condenser coil	220.00
9. 08000075	GT-032307	Fan shroud, condenser	11.00
10. 06004028		Filter dryer with service port	25.00
11. 06000155		Condensate pan	48.00
12. 07000234		Wicking material	24.00
13. 06001350	GT-031732	Tubing, drain, clear plastic, per foot, 3/4" ID	3.50
14. 06000845	GT-031539	Base, condensing unit	22.00
15. 06001615	GT-033013	Automatic defrost timer 4hr.	32.00
16. 06001313	GT-031400	Condensing unit power cord	20.00
06001673	GT-031809	Capillary tubing 48" X 0.036" (prior to Serial #134-106565-F)	10.00
09000527		Capillary tubing 65" X 0.049" (Serial #134-106565-F and after)	20.00
17. 06001384	GT-032501	Accumulator, suction line	40.00

* KC52 production began with serial number 134099618N.

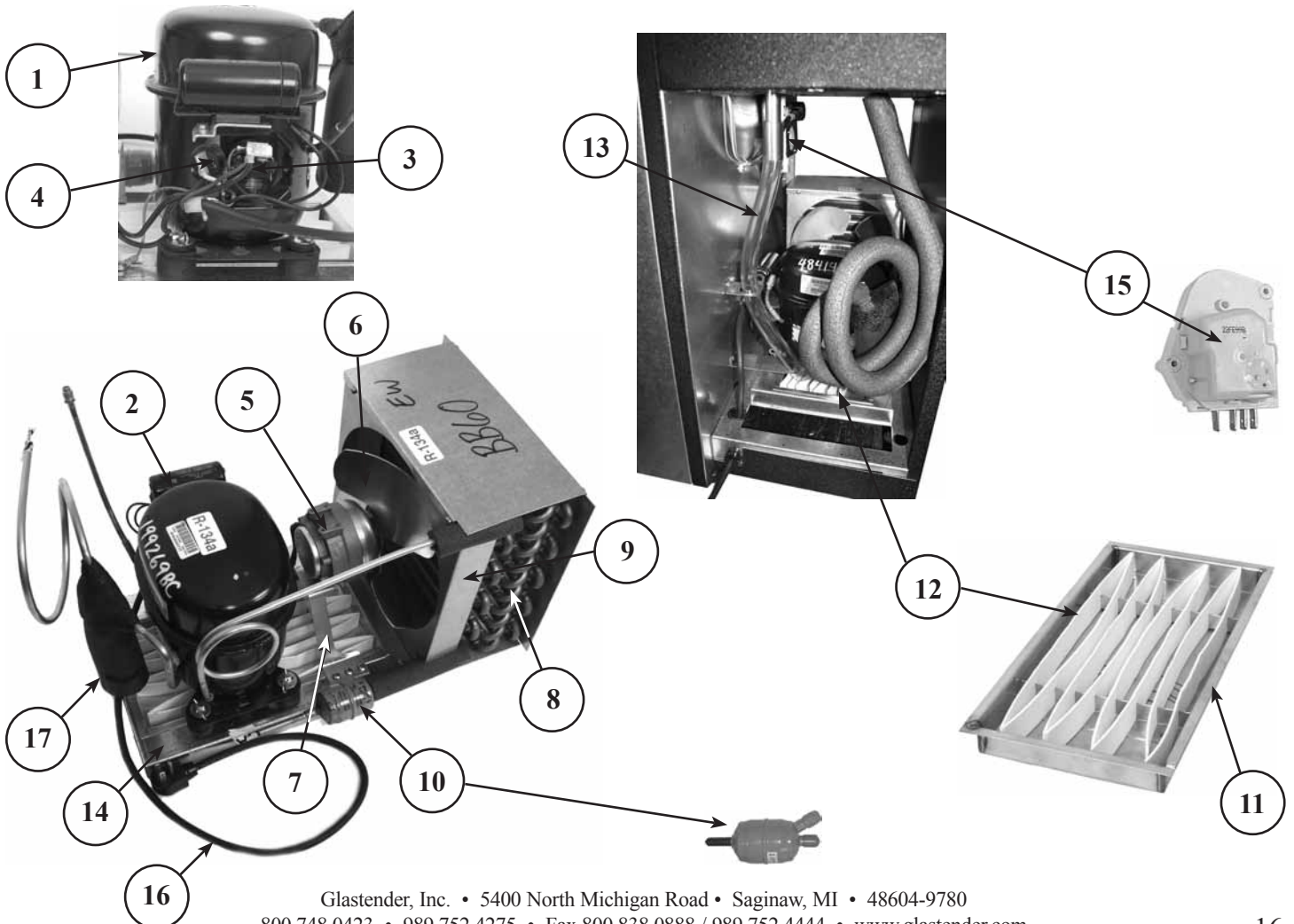

<u>PART NO.</u>	<u>OLD PART NO.</u>	<u>DESCRIPTION</u>	<u>PRICE</u>
1. 07000173	GT-035008	1/3 HP Embraco compressor, R404a	\$450.00
2. 07000151	GT-032203	Start capacitor for 1/3 HP Embraco R404a compressor	25.00
3. 06001675	GT-034103	Relay for 1/3 HP Embraco R404a compressor	15.00
4. 07000127	GT-031205	Overload protector for 1/3 HP Embraco R404a compressor	15.00
5. 08000085	GT-035106	Condenser fan motor	110.00
6. 08000081	GT-032801	Condenser fan blade assembly	13.00
7. 06001319	GT-031512	Condenser fan motor mounting bracket	5.00
8. 06001393	GT-032619	Condenser coil	230.00
9. 08000075	GT-032307	Fan shroud, condenser	11.00
10. 06004028		Filter dryer with service port	25.00
11. 06000155		Condensate pan	48.00
12. 07000234		Wicking material	24.00
13. 06001350	GT-031732	Tubing, drain, clear plastic, 3/4" dia, per foot	3.50
14. 06000845	GT-031539	Base, condensing unit	22.00
15. 06001615	GT-033013	Automatic defrost timer 4hr.	32.00
16. 06001313	GT-031400	Condensing unit power cord	20.00
06001676	GT-031810	Cap tube 84" x .049	20.00
17. 06001384	GT-032501	Accumulator, suction line	40.00

*KC72 Endwall configuration production began with serial number 404103097N.

*KC84 Endwall configuration production began with serial number 404103109N.

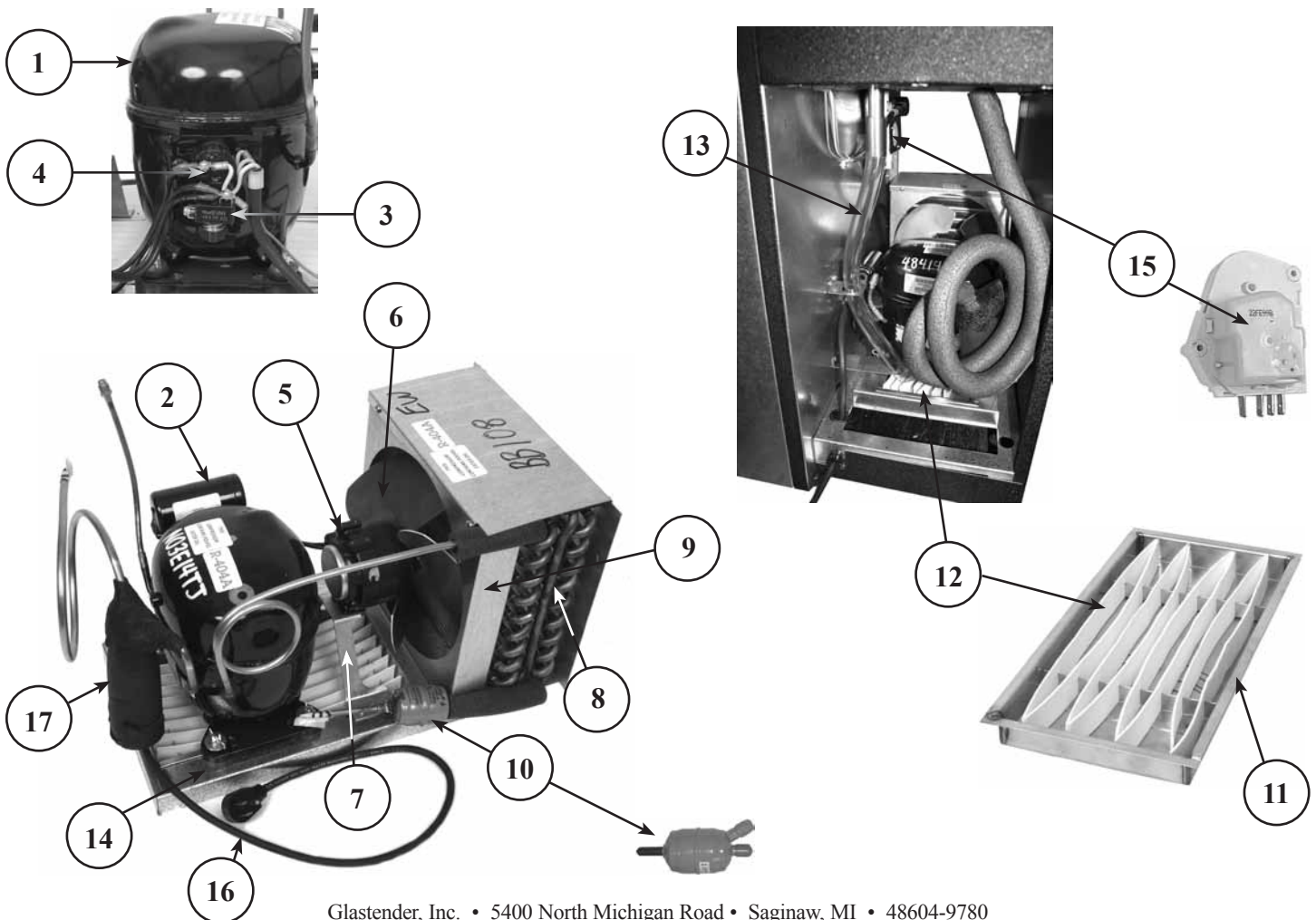

COMPRESSOR AND CONDENSER RELATED PARTS FOR KC48



PART NO.	OLD PART NO.	DESCRIPTION	PRICE
1. 07000172	GT-035002	1/3 HP Aspera compressor, R22	\$500.00
2. 06001379	GT-032201	Start capacitor for 1/3 HP Aspera R22 compressor	20.00
3. 06001414	GT-034103	Relay for 1/3 HP Aspera R22 compressor	14.00
4. 08000068	GT-031202	Overload protector for 1/3 HP Aspera R22 compressor	12.00
06001443	GT-035025	1/3 HP Tecumseh compressor, R22 (same models, after 2/00)	400.00
06001380	GT-032206	Start capacitor for 1/3 HP Tecumseh R22 compressor	20.00
07000168	GT-034112	Relay for 1/3 HP Tecumseh R22 compressor	16.00
07000128	GT-031207	Overload protector for 1/3 HP Tecumseh R22 compressor	12.00
5. 08000085	GT-035106	Condenser fan motor, 16W	110.00
6. 09000299	GT-032805	Condenser fan blade	10.50
7. 06000586		Condenser fan motor mounting bracket	9.00
8. 06001392	GT-032618	Condenser coil (19"L x 7"W x 3-1/2"D)	175.00
9. 06000405		Fan shroud, condenser (prior to 9/6/06)	11.00
06002853		Housing, condenser fan, 8" models (after 9/6/06)	11.00
06002854		Bracket, condenser fan, top, 8" models (after 9/6/06)	6.00
06002855		Bracket, condenser fan, bottom, 8" models (after 9/6/06)	6.00
10. 06004028		Filter dryer with service port	25.00
11. 06001651	GT-038024	Condensate pan (7-7/8"L x 7-1/2"W x 1-1/2"D)	42.00
12. 07000234		Wicking material	24.00
13. 06001461		Elbow, white nylon, 1/2" x 1/2"	2.00
14. 06001345	GT-031716	Tubing, drain, clear plastic, 1/2" ID x 5/8" OD, per foot	1.45
15. 06001397	GT-033000	Automatic defrost timer 6hr.	32.00
16. 06001313	GT-031400	Condensing unit power cord	20.00
06001614	GT-032510	Cap tube 110" X .054	20.00
17. 06001384	GT-032501	Accumulator, suction line	40.00

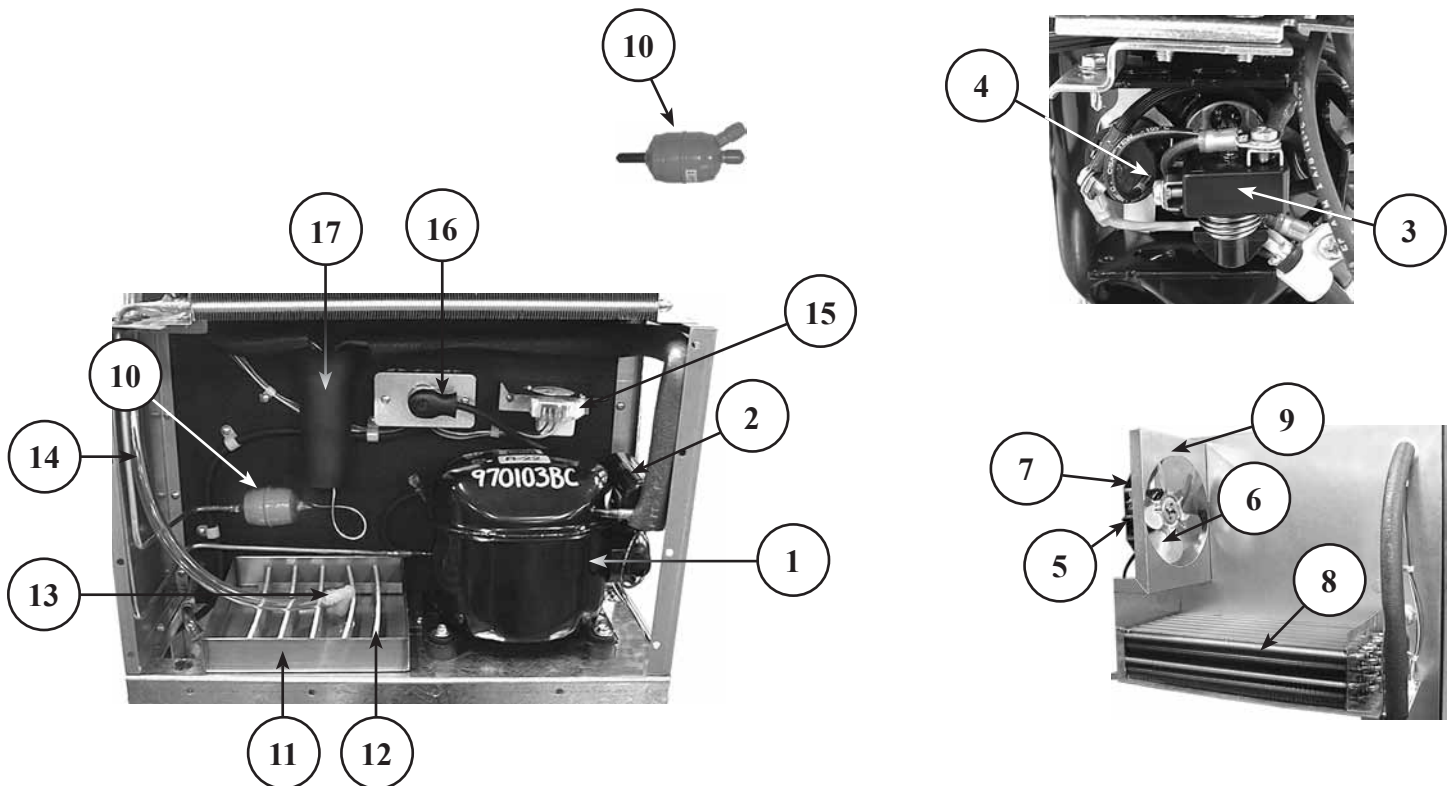

<u>PART NO.</u>	<u>OLD PART NO.</u>	<u>DESCRIPTION</u>	<u>PRICE</u>
1. 07000173	GT-035008	1/3 HP Aspera compressor, R404a	\$450.00
2. 07000151	GT-032203	Start capacitor for 1/3 HP Aspera R404a compressor	25.00
3. 06001675	GT-034115	Relay for 1/3 HP Aspera R404a compressor	15.00
4. 07000127	GT-031205	Overload protector for 1/3 HP Aspera R404a compressor	15.00
07000175	GT-035026	1/3 HP Tecumseh compressor, R404a (after 1/00)	375.00
06001380	GT-032206	Start capacitor for 1/3 HP R404a Tecumseh compressor	20.00
07000168	GT-034112	Relay for 1/3 HP R404a Tecumseh compressor	16.00
07000128	GT-031207	Overload protector for 1/3 HP R404a Tecumseh compressor	12.00
5. 08000085	GT-035106	Condenser fan motor	110.00
6. 08000081	GT-032801	Condenser fan motor blade assembly	13.00
7. 06001319	GT-031512	Condenser fan motor mounting bracket	5.00
8. 08000076	GT-032601	Condenser coil (10"L x 7-15/16"W x 4"D)	220.00
9. 08000075	GT-032307	Fan shroud, condenser	11.00
10. 06004028		Filter dryer with service port	25.00
11. 06001648	GT-038001	Condensate pan (13-3/4"L x 9-1/2"W x 1"D)	58.00
12. 07000234	GT-038201	Wicking material (2 required)	24.00
13. 06001461		Elbow, white nylon, 1/2" x 1/2"	2.00
14. 06001345	GT-031716	Tubing, drain, clear plastic, 1/2" ID x 5/8" OD, per foot	1.45
15. 08000074	GT-031532	Base, condensing unit	30.00
16. 06001397	GT-033000	Automatic defrost timer 6hr.	32.00
17. 06001313	GT-031400	Condensing unit power cord	20.00
06001614	GT-032510	Cap tube 110" X .054	20.00
06001384	GT-032501	Accumulator, suction line	40.00

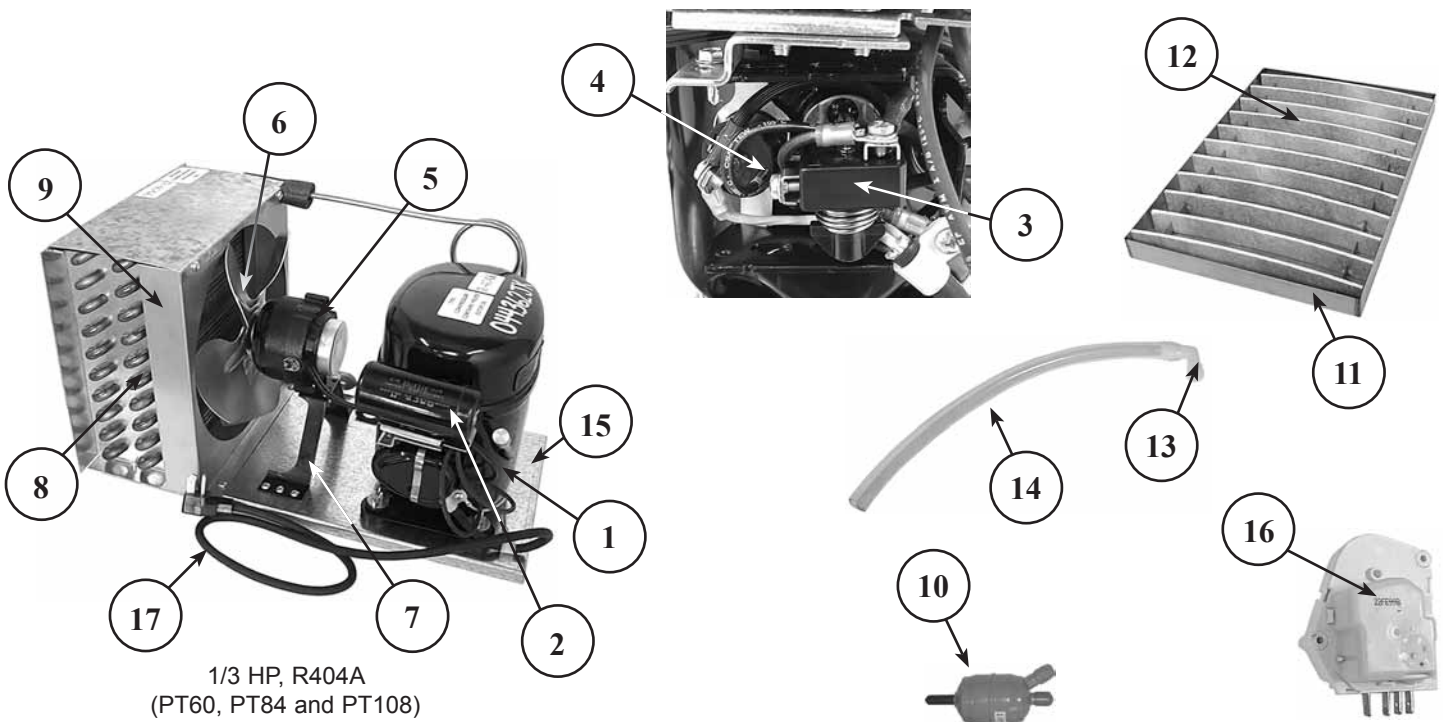

COMPRESSOR AND CONDENSER RELATED PARTS FOR FV24 AND FV48



PART NO.	OLD PART NO.	DESCRIPTION	PRICE
1. 11000082	GT-035005	1/5 HP Aspera compressor, R22 (before 04/00)	\$535.00
2. 06001379	GT-032201	Start capacitor for 1/5 HP Aspera R22 compressor	20.00
3. 06001675	GT-034115	Relay for 1/5 HP Aspera R22 compressor	15.00
4. 08000069	GT-031204	Overload protector for 1/5 HP Aspera R22 compressor	15.00
06001444	GT-035027	1/5 HP Tecumseh compressor, R22 (after 04/00)	490.00
06001382	GT-032207	Start capacitor for 1/5 HP Tecumseh R22 compressor	15.00
06001415	GT-034113	Relay for 1/5 HP Tecumseh R22 compressor	19.00
06001303	GT-031208	Overload protector for 1/5 HP Tecumseh R22 compressor	10.00
5. 07000152	GT-032302	Fan shroud, condenser	15.00
6. 06001449	GT-035114	Condenser fan motor, 6W	95.00
7. 07000155	GT-032803	Condenser fan motor blade	10.00
8. 06001321	GT-031515	Condenser fan motor mounting bracket	5.00
9. 08000078	GT-032607	Condenser coil (13"L x 8-1/4"W x 2-1/2"D)	145.00
10. 06004028		Filter dryer with service port	25.00
11. 08000125	GT-038006	Condensate pan (17"L x 3-7/8"W x 1-1/2"D), FV24	60.00
12. 07000234	GT-038201	Wicking material (2 required for the FV48)	24.00
07000260		Condensate pan, FV48	65.00
13. 06001461		Elbow, white nylon, 1/2" x 1/2"	2.00
14. 06001345	GT-031716	Tubing, drain, clear plastic, 1/2" ID x 5/8" OD, per foot	1.45
15. 06001397	GT-033000	Automatic defrost timer 6hr.	32.00
16. 06001313	GT-031400	Condensing unit power cord	20.00
11000120	GT-031717	Cap tube 60" X .036	20.00
06001384	GT-032501	Accumulator, suction line	40.00

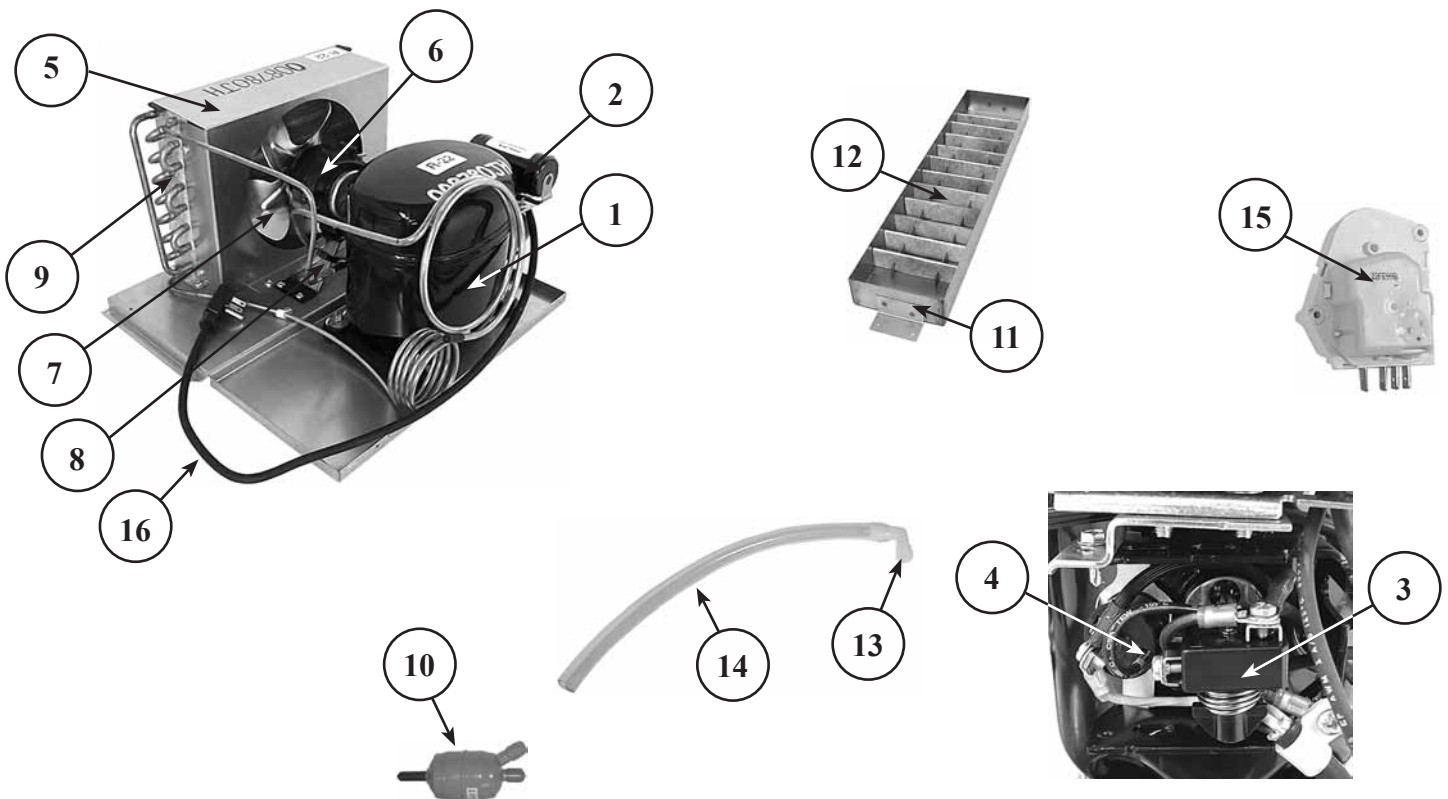

PART NO.	OLD PART NO.	DESCRIPTION	PRICE
1. 06002423	GT-034304	Expansion valve, remote model, R22 refrigerant	\$115.00
06001416	GT-034309	Expansion valve, remote model, R134a refrigerant	115.00
06001417	GT-034311	Expansion valve, remote model, R404a refrigerant	115.00
2. 06001385	GT-032502	Filter dryer for remote coolers	20.00
3. 06001405	GT-033202	Thermostat with knob and plate [Selco]	50.00
4. 06001632	GT-038419	Knob only	3.00
5. 06001431	GT-034935	Rope lighting, replacement kit, for BB24, BB36	41.00
06001432	GT-034936	Rope lighting, replacement kit, for BB60, ND48, ND52, LPT36	61.00
06001433	GT-034937	Rope lighting, replacement kit, for BB84, ND72	81.00
06001434	GT-034938	Rope lighting, replacement kit, for BB108	101.00
6. 06001419	GT-034905	Light, fluorescent, plug-in	22.00
7. 01000549	GT-033400	Switch (prior to 9/04)	14.00
06001412	GT-033421	Switch	5.00
8. 06000888	GT-033310	Electrical Outlet, black (Triboro with no ground)	7.50
06001409	GT-033304	Receptacle, snap in with ground	5.00
9. 06001589	GT-041308	Solenoid valve, remote cooler	85.00
10. 06001590	GT-041309	Solenoid Coil, 120V, remote cooler	50.00
11. 06001553	GT-038420	Thermometer	6.00
12. 06001424	GT-034925	Light bulb cover, clear plastic	10.00
13. 08000286		Light socket with wire lead, set of 2	4.00
14. 06001425	GT-034926	Light bulb, GE# F6T5	13.00
06001426	GT-034927	Ballast for one light evaporator housing	20.00
06004141		Kit, fluorescent light conversion, replaces single ballast for dual light systems	125.00
06001427	GT-034928	Ballast for two light evaporator housing	60.00
06001421	GT-034912	Starter base, fluorescent light	7.00
06001420	GT-034911	Starter, fluorescent light, 4-6-8 watt	5.00
12000089	GT-034908	Light bulb, fluorescent, 36" long, T12 (prior to 08-07)	13.50
06001423	GT-034917	Ballast, 120V, 2 lamp, rapid start (use with 12000089)	76.00
12000326		Bulb, Fluorescent 36", 25W T8 (after 08-07)	14.00
12000323		Ballast, 32W T8 (use with 12000326)	76.00
12000530		Lamp holder, Fluorescent light, set of 2	9.50

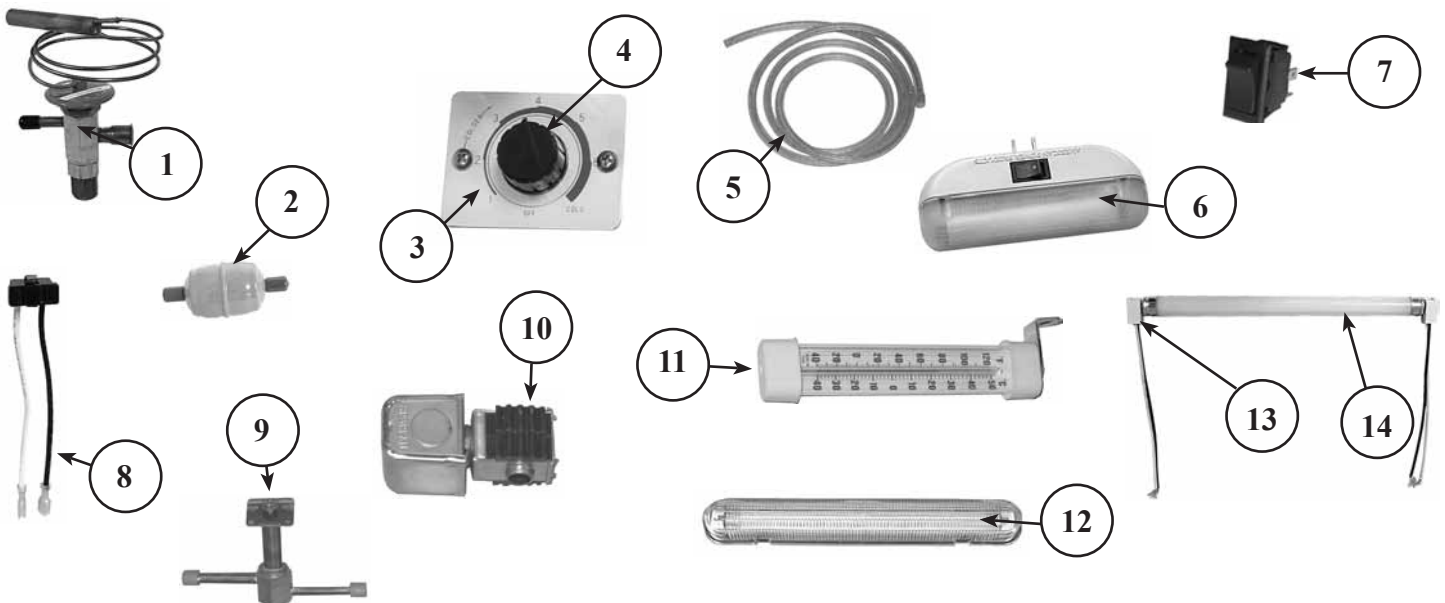

EVAPORATORS AND RELATED PARTS



1
Blower Motor Assembly
Endwall BB84, BB108,
ND72, ND92, KC52, KC72, KC84



2
Evaporator Fan Replacement Parts
Endwall BB36, BB60, ND52 & All Non Endwall Models

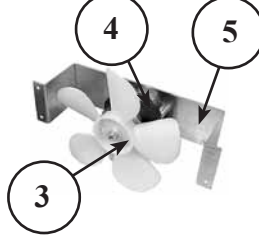

15
06000174
Drain Pan for **BB24 Self-contained, KC24**
(8-1/2" L, 3-7/8" H, 1" W)



16
06003683
Evaporator Drain Pan, Left, for **Endwall Models**
BB36, BB60, BB84, BB108,
ND52, ND72, ND92,
KC52, KC72, and KC84
(19-1/8" L, 5" H, 1/2" W)

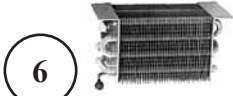

6
06001387
Evaporator Coil for
BB24 Self-contained, KC24
(8" L, 4-1/8" H, 3-1/2" W)

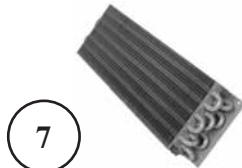

7
06001893
Evaporator Coil for
Endwall Models
BB36, BB60, BB84, BB108,
ND52, ND72, ND92,
KC52, KC72, KC84
(16" L, 6" H, 4" W)



8
06001390
Evaporator Coil for
BB24 Remote, BB36, LP48,
LP60, PT48, FV24, FV48
(18-3/4" L, 2-5/8" H, 4" W)



9
06001391
Evaporator Coil for
LP72, LP84, LP96, LP108,
PT72, PT84, PT96, PT108
(39-1/4" L, 2-5/8" H, 4" W)

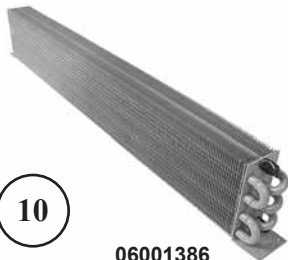

10
06001386
Evaporator Coil for
Non Endwall Models
BB48, BB60, BB72, BB84,
ND48, ND40, ND52, ND60 ND72,
KC48, KC72, KC84
(27-1/2" L, 4" H, 1-7/8" W)



11
08000077
Evaporator Coil for
BB96, BB108, ND80
(38-1/2" L, 4" H, 1-7/8" W)



17
06000481
Drain Pan for **BB96, BB108**
(39-1/2" L, 2-5/8" H, 3/4" W)



18
06000620
Drain Pan for **PT48**
(20-3/8" L, 4-3/4" H, 1" W)



19
06000607
Drain Pan for **PT72, PT84, PT96, PT108**
(41-1/8" L, 4-3/4" H, 1" W)



20
06000613
Drain Pan for **BB24 Remote, BB36, LP48, LP60**
(20-3/8" L, 4-3/4" H, 1" W)



12



13



14



21
06000632
Drain Pan for **LP72, LP84, LP96, LP108**
(41-1/8" L, 4-3/4" H, 1" W)

22

EVAPORATORS AND RELATED PARTS

<u>PART NO.</u>	<u>OLD PART NO.</u>	<u>DESCRIPTION</u>	<u>PRICE</u>
1. 06001453	GT-035129	Blower motor assembly (Endwall BB84, BB108, ND72, ND92, KC52, KC72, KC84)	\$200.00
2. 06001383	GT-032301	Evaporator fan guard (Endwall BB36, BB60, ND52 & All Non Endwall Models)	12.00
3. 06001395	GT-032802	Evaporator fan motor blade, white plastic (All Non Endwall Models)	5.00
4. 06001445	GT-035107	Evaporator fan motor (Endwall BB36, BB60, ND52 & All Non Endwall Models)	35.00
5. 07000310	GT-031514	Evaporator fan motor mounting bracket (Endwall BB36, BB60, ND52 & All Non Endwall Models)	14.00
6. 06001387	GT-032605	Evaporator coil (BB24 Self-contained, KC24)	135.00
7. 06001893		Evaporator coil (Endwall Models BB36, BB60, BB84, BB108, ND52, ND72, ND92, KC52, KC72, KC84) (after 3/06)	210.00
06003051		Evaporator coil replacement kit (BB36, BB60, BB84, BB108, ND52, ND72, ND92 Endwall Models) (prior to 3/06) It is also necessary to purchase a drain pan, 06003684 or 06003683	220.00
8. 06001390	GT-032612	Evaporator coil (BB24 Remote, BB36, LP48, LP60, PT48, FV24, FV48)	220.00
06001394	GT-032628	Evaporator coil (PT60)	320.00
9. 06001391	GT-032613	Evaporator coil (LP72, LP84, LP96, LP108, PT84, PT96, PT108)	310.00
10. 06001386	GT-032603	Evaporator coil (Non Endwall Models, BB48, BB60, BB72, BB84, ND40, ND48, ND52, ND60 ND72, KC48, KC72, KC84)	170.00
11. 08000077	GT-032604	Evaporator coil (BB96, BB108, ND80)	285.00
12. 06001110		TXV valve extension Cover (3 door remote coolers)	12.00
13. 06001111		TXV valve extension Cover (4 door remote coolers)	12.00
14. 06001105		TXV valve Cover (all remote coolers)	12.00
15. 06000174	GT-038002	Evaporator drain pan (BB24 Self-contained, KC24)	48.00
06000618		Evaporator drain pan (KC24) (prior to 04/14/06)	54.00
16. 06003684		Evaporator drain pan, Right (Endwall Models BB36, BB60, BB84, BB108, ND52, ND72, ND92, KC52, KC72, KC84) (after 3/06)	60.00
06003683		Evaporator drain pan, Left (Endwall Models BB36, BB60, BB84, BB108, ND52, ND72, ND92, KC52, KC72, KC84) (after 3/06)	60.00
06000844	GT-038027	Evaporator drain pan (Endwall Models BB36, BB60, BB84, BB108, ND52, ND72, ND92) (prior to 3/06)	60.00
17. 06000479	GT-038003	Evaporator drain pan (Non Endwall Models, BB48, BB60, BB72, BB84, ND52, ND72, KC48, KC72, KC84)	54.00
18. 06000481	GT-038004	Evaporator drain pan (BB96, BB108)	60.00
06001185		Evaporator drain pan (PT60)	54.00
19. 06000620		Evaporator drain pan (PT48)	54.00
20. 06000607	GT-038018	Evaporator drain pan (PT72, PT84, PT96, PT108)	60.00
21. 06000613	GT-038019	Evaporator drain pan (BB24 Remote, BB36, LP48, LP60)	54.00
22. 06000632	GT-038020	Evaporator drain pan (LP72, LP84, LP96, LP108)	60.00
06000663		Evaporator drain pan (FV24, FV48)	54.00
06004182		Assembly, shroud, evaporator, 2-fan, 1-2 door e/w, 110 Volt	180.00
06004188		Assembly, shroud, evaporator, 2-fan, 1-2 door e/w, 110 Volt, digital t-stat	150.00

DOORS AND RELATED PARTS



PART NO.	OLD PART NO.	DESCRIPTION	PRICE
1. 06001462	GT-035402	Door handle, stainless	\$60.00
06001653	GT-035401	Door handle, brass	110.00
06001899		Door handle, tab style, glass door, right (Prior to 2003)	65.00
06003704		Door handle, tab style, glass door, left (Prior to 2003)	65.00
2. 06001536	GT-036602	Door lock, stainless	36.00
06004009		Key, #806, for stainless cooler door lock (06001536)	4.00
06001535	GT-036601	Door lock, brass	43.00
06004010		Key, #606, for brass cooler door lock (06001535)	4.00
06001677	GT-035406	Plug for door handle, stainless	1.00
06001678	GT-035408	Plug for door handle, brass	1.00
00000200	GT-038733	Screws for top of handle, stainless (set of 2), 10/32 x 1" PFH Machine Screw	1.00
00000016	GT-038779	Screws for top of handle, brass (set of 2), 10/32 x 5/8" PFH Machine Screw	1.00
00000046	GT-038759	Screw for bottom of handle, stainless, and screws for old style brackets	.50
00000043	GT-038748	Screw for bottom of handle, black	.50
3. 11000076	GT-032114	Hinge set, 120° swing, set of two w/screws and washers	25.00
4. 06002510	GT-032101	Hinge set, 180° swing, set of two (prior to 1/99 - w/ screws and washers)	25.00
5. 06001616	GT-032115	Hinge bracket, bottom, left (prior to 1/99 - w/ 2 screws)	15.00
06001617	GT-032116	Hinge bracket, bottom, right (prior to 1/99 - w/ 2 screws)	15.00
6. 06001372	GT-032120	Hinge set and brackets, 180° swing, left (complete with screws)	35.00
7. 06001373	GT-032121	Hinge set and brackets, 180° swing, right (complete with screws)	35.00
8. 06001322	GT-031543	Lock bracket	10.00
06001376	GT-032130	Hinge set & brackets for wood doors, 180° swing, left (complete with screws)	45.00
06001377	GT-032131	Hinge set & brackets for wood doors, 180° swing, right (complete with screws)	45.00
06001378	GT-032135	Lock bracket for wood doors	10.00
9. 06001304	GT-031307	Cooler door gasket, push-in style, black, 23-1/2" x 32-1/2" OD	42.00
06001305	GT-031308	Cooler door gasket, screw-on style (wooden doors before 6/9/90) 23½" x 32½" OD	42.00
06001307	GT-031317	Cooler door gasket, LP and FV models, black, 23½" x 26½" OD	42.00
06001309	GT-031323	Cooler door gasket, narrow door, black, 19½" x 32½" OD	42.00
10. 00000067	GT-038813	Screw for door hinges (4 required)	.50
11. 00000041	GT-038746	Bolts for brackets (6 required)	.50
12. 06000140		Hinge rail, bottom, front vent coolers (2 - 06001485 washers required, not included)	20.00
06001485	GT-036012	Plastic washer for hinge	1.00
06001569	GT-038495	Bushing for hinge (gray)	1.00
06001844		Standard laminated door trim rail kit	35.00
06001846		Laminated door trim rail kit, for narrow doors	35.00
06001847		Laminated door trim rail kit, for low profile narrow doors	35.00
06001845		Laminated door trim rail kit, for low profile doors	35.00

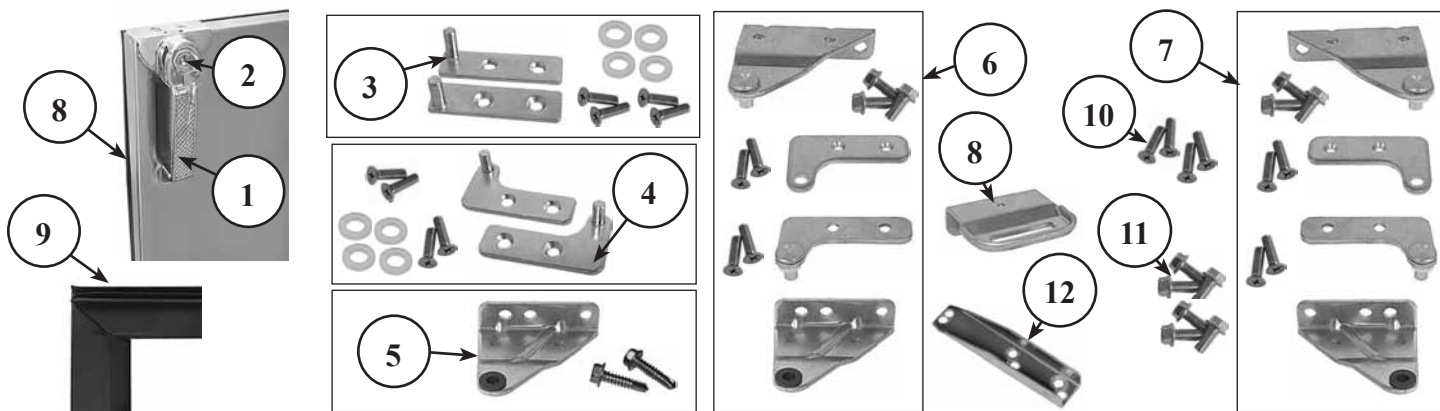

DOORS AND RELATED PARTS

REPLACEMENT DOORS FOR UNITS MANUFACTURED PRIOR TO JANUARY 1999

REPLACEMENT DOORS FOR BB, PT, RF, DS, KC72, AND KC84 MODELS

<u>PART NO.</u>	<u>OLD PART NO.</u>	<u>DESCRIPTION</u>	<u>PRICE</u>
06001489	GT-036208	Black vinyl clad door (prior to 1/99)	\$308.00
06001487	GT-036205	Unlaminated door (prior to 1/99)	308.00
06001488	GT-036207	Laminated door (prior to 1/99)	428.00
06001490	GT-036209	Stainless door (prior to 1/99)	358.00
06007221		Glass door, black (prior to 1/99)	598.00
06007222		Glass door, stainless (prior to 1/99)	648.00

REPLACEMENT DOORS FOR LP AND FV MODELS

06001505	GT-036267	Black vinyl clad door, low profile (prior to 1/99)	308.00
06001506	GT-036268	Unlaminated door, low profile (prior to 1/99)	308.00
06001507	GT-036269	Laminated door, low profile (prior to 1/99)	428.00
06001508	GT-036270	Stainless door, low profile (prior to 1/99)	358.00
06007226		Glass door, low profile, black (prior to 1/99)	598.00
06007225		Glass door, low profile, stainless (prior to 1/99)	648.00

REPLACEMENT DOORS FOR ND MODELS

06001511	GT-036273	Black vinyl clad door, narrow (prior to 1/99)	308.00
06001512	GT-036274	Unlaminated door, narrow (prior to 1/99)	308.00
06001513	GT-036275	Laminated door, narrow (prior to 1/99)	428.00
06001514	GT-036276	Stainless door, narrow (prior to 1/99)	358.00
06007224		Glass door, narrow , black (prior to 1/99)	598.00
06007223		Glass door, narrow, stainless (prior to 1/99)	648.00

NOTE: Door gaskets, handles and hinges are sold separately, see page 23 for part numbers

DOORS AND RELATED PARTS



REPLACEMENT DOORS FOR UNITS MANUFACTURED JANUARY 1999 AND AFTER

REPLACEMENT DOORS FOR BB, PT, RF, DS, AND KC MODELS

PART NO.	OLD PART NO.	DESCRIPTION	PRICE
06001517	GT-036280	Black vinyl clad door	\$308.00
06001518	GT-036281	Unlaminated door	308.00
06001519	GT-036282	Laminated door	428.00
1. 06001520	GT-036283	Stainless door	358.00
06001597		Glass door, black	598.00
06001596		Glass door, stainless	648.00

REPLACEMENT DOORS FOR LP AND FV MODELS

2. 06001523	GT-036286	Black vinyl clad door, low profile	308.00
06001524	GT-036287	Unlaminated door, low profile	308.00
06001525	GT-036288	Laminated door, low profile	428.00
06001526	GT-036289	Stainless door, low profile	358.00
06001600		Glass door, low profile, black	598.00
3. 06001599		Glass door, low profile, stainless	648.00

REPLACEMENT DOORS FOR ND MODELS

06001529	GT-036292	Black vinyl clad door, narrow	308.00
06001530	GT-036293	Unlaminated door, narrow	308.00
4. 06001531	GT-036294	Laminated door, narrow	428.00
06001532	GT-036295	Stainless door, narrow	358.00
06001603		Glass door, narrow, black	598.00
06001602		Glass door, narrow, stainless	648.00

NOTE: Door gaskets, handles and hinges are sold separately, see page 23 for part numbers

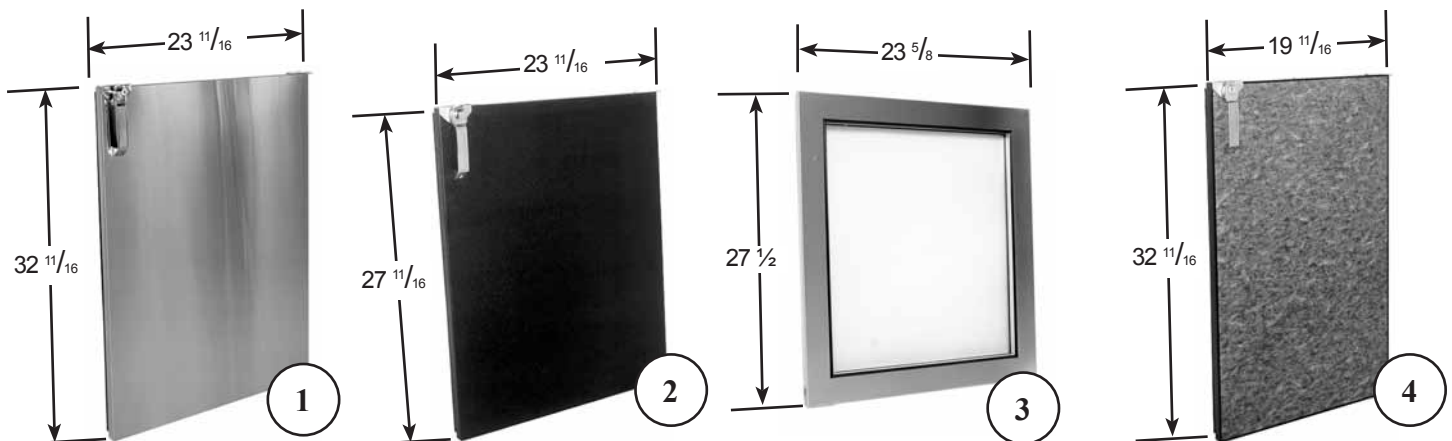

REPLACEMENT GLASS DOORS FOR UNITS MANUFACTURED SEPTEMBER 2003 AND AFTER

NOTICE: In September of 2003, we released new style glass doors for our vertical door coolers. These new style doors fit all of our units manufactured AFTER January 1999, However these new style glass doors look different than the glass doors manufactured BETWEEN January 1999 and September 2003. Please consider this fact if you need to match the look of your replacement glass door with that of existing glass doors. If you need to order the style of glass doors manufactured between January 1999 and September 2003, please refer to page 25.

REPLACEMENT DOORS FOR BB, PT, RE, DS, AND KC MODELS

PART NO.	OLD PART NO.	DESCRIPTION	PRICE
06001596	GT-042000	Stainless Steel Glass Door	\$648.00
06001597	GT-042001	Black Vinyl Clad Glass Door	598.00
15. 06001598	GT-042002	Laminated Glass Door	718.00

REPLACEMENT DOORS FOR LP AND FV MODELS

PART NO.	OLD PART NO.	DESCRIPTION	PRICE
16. 06001599	GT-042010	Stainless Steel Glass Door	648.00
06001600	GT-042011	Black Vinyl Clad Glass Door	598.00
06001601	GT-042012	Laminated Glass Door	718.00

REPLACEMENT DOORS FOR ND MODELS

PART NO.	OLD PART NO.	DESCRIPTION	PRICE
06001602	GT-042020	Stainless Steel Glass Door	648.00
17. 06001603	GT-042021	Black Vinyl Clad Glass Door	598.00
06001604	GT-042022	Laminated Glass Door	718.00

NOTE: Door gaskets, handles, and hinges are sold separately, see page 23 for part numbers



15

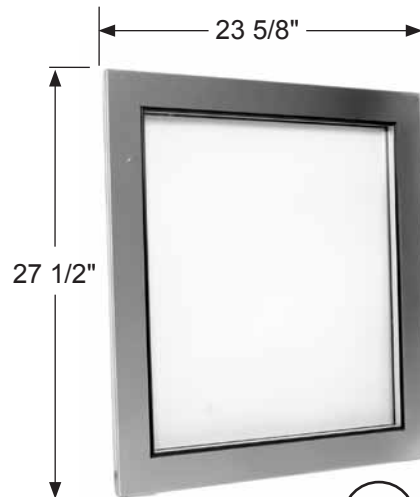

16



17

SHELVING, RACKS AND RELATED PARTS



PART NO.	OLD PART NO.	DESCRIPTION	PRICE
1. 06001399	GT-033101	18 ⁷ / ₈ " x 20 ¹ / ₈ " grey coated shelf (fits BB24, BB36, FV24, ND72 middle door and refrig. end of remote PT models)	\$77.00
2. 06001400	GT-033102	18 ⁷ / ₈ " x 22-1/16" grey coated shelf with corner notch (fits end doors on BB, and LP models and both doors on FV48)	77.00
06001401	GT-033103	18 ⁷ / ₈ " x 23 ³ / ₈ " grey coated shelf (fits middle doors on BB, LP, PT and RF models)	77.00
06001402	GT-033125	18 ⁷ / ₈ " x 18-1/16" grey coated shelf (fits end doors on ND models)	77.00
06001403	GT-033127	18 ⁷ / ₈ " x 22-1/16" grey coated shelf (fits end doors on PT and RF models)	77.00
06003971		18 ⁷ / ₈ " x 22-1/16" grey coated shelf (fits NDPT48 and 72 coolers)	77.00
06001404		Shelf divider	25.00
06001278		Floor, stainless, fits BGS-18	104.00
06001279		Floor, stainless, fits BGS-24	137.00
06001280		Floor, stainless, fits BGS-30	169.00
06001281		Shelf, stainless, fits BGS-18	104.00
06001282		Shelf, stainless, fits BGS-24	137.00
06001283		Shelf, stainless, fits BGS-30	169.00
06001284		Shelf angle for BGS	20.00
11000081	GT-033126	13 ¹ / ₂ " X 32 ¹ / ₄ " coated shelf (fits CM models)	106.00
07000159		19 ⁵ / ₈ " X 19 ⁵ / ₈ " shelf (fits MFV bottom and middle)	50.00
07000160		9-13/16" X 19 ⁵ / ₈ " shelf (fits MFV top)	35.00
3. 06000165		18 ⁷ / ₈ " X 20 ¹ / ₈ " dry storage shelf (fits DS24 manufactured before 04/03) (fits BB24, BB36, FV24, ND72 middle door and refrig. end of remote PT models)	63.00
06001195	GT-033135	20 ⁵ / ₈ " X 21 ¹ / ₂ " dry storage shelf (fits DS24 manufactured after 04/03)	63.00
4. 06001196	GT-037707	Floor for DS24 (manufactured after 04/03)	63.00
06000167	GT-033129	18 ⁷ / ₈ " X 15 ⁷ / ₈ " dry storage shelf (fits DS36)	63.00
06000168		18 ⁷ / ₈ " X 18-1/16" dry storage shelf (fits end doors on ND models)	63.00
06000169	GT-033130	18 ⁷ / ₈ " X 22-1/16" dry storage shelf (fits DS48 and DS72 ends)	63.00
06000170	GT-033131	18 ⁷ / ₈ " X 23 ³ / ₈ " dry storage shelf (fits DS72, middle)	63.00
06001557	GT-038434	Pilaster	5.00
06001574	GT-038833	Thumbscrew, stainless steel, for pilaster	1.50
06001565	GT-038468	Clip, for pilaster, stainless steel	1.50
00000018		Nut, acorn, 8/32" natural nylon	1.00
06001579	GT-040305	ABS Scuff Channel with mounting screws	26.00
06001580	GT-040328	ABS Scuff Channel (ND models) with mounting screws	26.00
5. W-RACK-18		Wine racks, set of two for 18-1/16" shelf (shelf not included)	88.00
W-RACK-20		Wine racks, set of two for 20 ¹ / ₈ " shelf (shelf not included)	88.00
W-RACK-22		Wine racks, set of two for 22-1/16" shelf (shelf not included)	88.00
06001610	K-RACK-ND	Keg rack, stainless, 18 ³ / ₄ " (ND end)	195.00
06000041	K-RACK-KC	Keg rack, stainless, 20 ³ / ₄ " (KC24 models manufactured before 04/14/06)	195.00
06001608	K-RACK-21	Keg rack, stainless, 20 ³ / ₄ " (BB self contained & KC24, BB end & ND middle)	195.00
6. 06001609	K-RACK-24	Keg rack, stainless, 24 ¹ / ₂ " (BB middle doors)	195.00
06003035	K-RACK-PT	Keg rack, stainless, 24 ¹ / ₂ " (PT end)	195.00
06000043		Keg rack, stainless, 24 ¹ / ₂ " (PT middle)	195.00

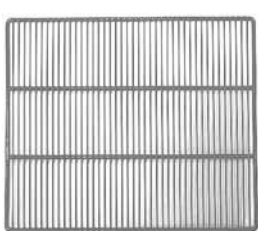

1

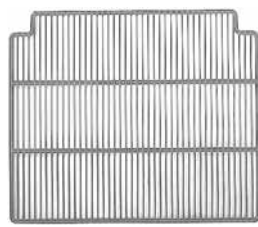

2

3



Dry Storage Shelf

18-7/8" x 20-1/8"

18-7/8" x 22-1/16"

4



DS24 Dry Storage Floor

5

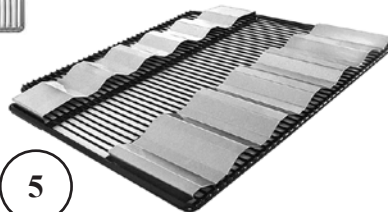

Wine Rack
(shelf not included)

6



Keg Rack

REFRIGERATION COMPARTMENT COVERS

REFRIGERATION COMPARTMENT COVERS FOR BB24 AND KC24 MODELS AFTER 4/14/06

PART NO.	OLD PART NO.	DESCRIPTION	PRICE
06002814		Panel, access, BB24/KC24	\$44.00

REFRIGERATION COMPARTMENT COVERS FOR ENDWALL BB, ND, KC52, KC72 & KC84 MODELS

1. 06000624	GT-036180	Refrigeration compartment cover, black vinyl clad (33-1/2"H, 11-3/4"L, 1-3/8"W)	110.00
06003050	GT-036181	Refrigeration compartment cover, stainless steel (33-1/2"H, 11-3/4"L, 1-3/8"W)	168.00
06000661		Refrigeration compartment cover, laminated (33-1/2"H, 11-3/4"L, 1-3/8"W)	220.00

REFRIGERATION COMPARTMENT COVERS FOR PT, AND NON ENDWALL BB, ND52, ND72, KC72, AND KC84 MODELS

2. 06001645		12" refrigeration compartment cover, black vinyl clad (33-1/2"H, 11-3/4"L, 1-3/8"W)	110.00
06001646		12" refrigeration compartment cover, stainless steel (33-1/2"H, 11-3/4"L, 1-3/8"W)	168.00
06001736		12" refrigeration compartment cover, laminated (33-1/2"H, 11-3/4"L, 1-3/8"W)	220.00
3. 06000662	GT-036182	12" low refrigeration compartment cover, black vinyl clad (19-1/2"H, 11-3/4"L, 1-3/8"W)	105.00
06001737	GT-036183	12" low refrigeration compartment cover, stainless steel (19-1/2"H, 11-3/4"L, 1-3/8"W)	156.00

REFRIGERATION COMPARTMENT COVERS FOR LP MODELS

06001738	GT-036186	12" refrigeration compartment cover, black vinyl clad (27-1/2"H, 11-3/4"L, 1-3/8"W)	110.00
4. 06001739	GT-036187	12" refrigeration compartment cover, stainless steel (27-1/2"H, 11-3/4"L, 1-3/8"W)	168.00

REFRIGERATION COMPARTMENT COVERS FOR ND48 AND KC48 MODELS

5. 06001740	GT-036190	8" refrigeration compartment cover, black vinyl clad, (33-1/2"H, 7-3/4"L, 1-3/8"W)	50.00
06001741	GT-036191	8" refrigeration compartment cover, stainless steel, (33-1/2"H, 7-3/4"L, 1-3/8"W)	90.00

REFRIGERATION COMPARTMENT COVERS FOR FV24 AND FV48 MODELS

6. 07000202	GT-036129	Refrigeration compartment cover, black vinyl clad, (FV24) (9-3/8"H, 20-7/8"L, 3/8"W)	40.00
07000203	GT-036130	Refrigeration compartment cover, stainless steel, (FV24) (9-3/8"H, 20-7/8"L, 3/8"W)	80.00
06001742		Refrigeration compartment cover, black vinyl clad, (FV48) (9-3/8"H, 44-7/8"L, 3/8"W)	55.00
06001743		Refrigeration compartment cover, stainless steel, (FV48) (9-3/8"H, 44-7/8"L, 3/8"W)	90.00

REFRIGERATION COMPARTMENT COVERS FOR 18" WIDE COMPRESSOR COMPARTMENTS

06001744	GT-036195	Refrigeration compartment cover, black vinyl clad (33-1/2"H, 17-3/4"L, 1-3/8"W)	88.00
06001745	GT-036196	Refrigeration compartment cover, stainless steel (33-1/2"H, 17-3/4"L, 1-3/8"W)	144.00
7. 06001746	GT-036197	Low refrigeration compartment cover, black vinyl clad (19-1/2"H, 17-3/4"L, 1-3/8"W)	77.00
06001735	GT-036198	Low refrigeration compartment cover, stainless steel (19-1/2"H, 17-3/4"L, 1-3/8"W)	126.00

REFRIGERATION COMPARTMENT COVERS RELATED PARTS

8. 06001360	GT-032005	Grill insert, refrigeration compartment cover, polypropylene, black	25.00
9. 06001361	GT-032006	Grill insert, refrigeration compartment cover, polypropylene, gray	25.00
06001546	GT-037023	Filter, refrigeration compartment grill insert	5.00
10. 06001848		Laminated compressor compartment trim rail kit, for BB, PT, and ND models	39.00
06001849		Laminated compressor compartment trim rail kit, for LP models	39.00
06001850		Laminated compressor compartment trim rail kit, for special low profile compartments	39.00
06001555		Rubber Bumper	2.15

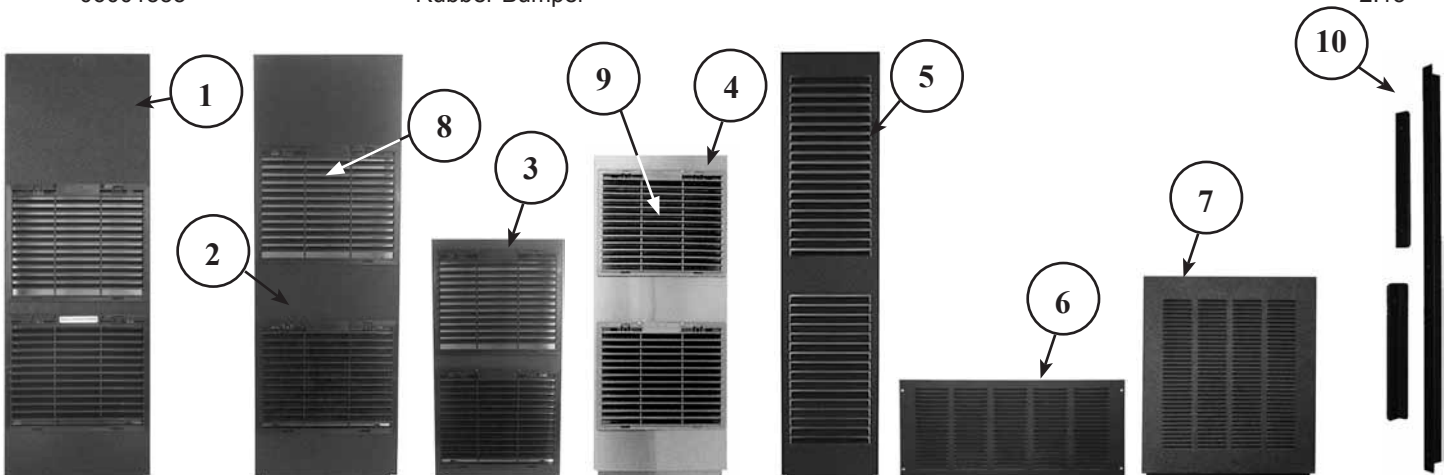

220 VOLT ELECTRICAL PARTS



BB24 SELF CONTAINED & KC24 COMPRESSOR, CONDENSER & RELATED PARTS

<u>PART NO.</u>	<u>DESCRIPTION</u>	<u>PRICE</u>
06001437	Compressor, 1/6HP, 220V, 50Hz, R134a	\$435.00
06004143	Relay, compressor, 1/6HP, 220V/50Hz, R134a	15.00
06004144	Overload protector, compressor, 1/6HP, 220V/50Hz, R134a	15.00
06001398	Automatic defrost timer, 6 hour, 220V, 50Hz	32.00
06001448	Condenser fan motor, 220V	50.00

STANDARD BB36 COMPRESSOR, CONDENSER & RELATED PARTS

11000083	Compressor, 1/5 HP, 220V, 50Hz, R22	\$485.00
11000196	Start capacitor, 1/5 HP, R22, 220V/50Hz Tecumseh compressor	15.00
11000198	Relay, 1/5 HP, R22, 220V/50Hz Tecumseh compressor	19.50
11000199	Overload protector, 1/5 HP, R22, 220V/50Hz Tecumseh	15.00
09000337	Condenser fan motor, 220V, 16 watt	140.00
06001398	Automatic defrost timer, 6 hour, 220V, 50 Hz	32.00

LP60, LP84, LP108, NON ENDWALL BB60, BB84, BB108, ND52, ND72, ND92, KC48, KC72, KC84

06001436	Compressor, 1/3 HP, 220V, 50Hz, R22	\$500.00
06001793	Start capacitor, for 1/3 HP R404A and R22 compressor, 220/50Hz	25.00
06004146	Relay, compressor, 1/3HP, 220V/50Hz, R22	15.00
06004147	Overload protector, compressor, 1/3HP, 220V/50Hz, R22	15.00
09000337	Condenser fan motor, 220V, 16 watt	140.00
06001398	Automatic defrost timer, 6 hour, 220V, 50 Hz	32.00

BB36, BB60, ND52, & KC52 COMPRESSOR & CONDENSER RELATED PARTS FOR ENDWALL MODELS

06001440	Compressor, 1/3 HP, 220V, 50Hz, R134a	\$465.00
06004203	Relay, 1/3 HP 220V 50Hz R134a Tecumseh compressor	12.00
06004057	Overload protector, 1/3 HP 220V 50Hz R134a Tecumseh compressor	17.00
11000196	Start capacitor, 1/3 HP 220V 50Hz R134a Tecumseh compressor	15.00
06001451	Condenser fan motor, 9 watt, 220V 50Hz	120.00
06001398	Automatic defrost timer, 6 hour, 220V, 50 Hz	32.00

220 VOLT ELECTRICAL PARTS

BB84, BB108, ND72, ND92, KC72 & KC84 COMPRESSOR & CONDENSER RELATED PARTS FOR ENDWALL MODELS

06001438	Compressor, 1/3 HP, 220V, 50Hz, R404a	\$510.00
06001793	Start capacitor, for 1/3 HP R404A and R22 compressor, 220/50Hz	25.00
06001794	Relay, 1/3 HP 220V 50Hz R404a compressor	15.00
06001795	Overload protector, 1/3 HP 220V 50Hz R404a compressor	15.00
09000337	Condenser fan motor, 220V, 16 watt	140.00
06001398	Automatic defrost timer, 6 hour, 220V, 50 Hz	32.00

PT60, PT84 & PT108 COMPRESSOR & CONDENSER RELATED PARTS

06001438	Compressor, 1/3 HP, 220V, 50Hz, R404a	\$510.00
06001793	Start capacitor, for 1/3 HP R404A and R22 compressor, 220/50Hz	25.00
06001794	Relay, 1/3 HP 220V 50Hz R404a compressor	15.00
06001795	Overload protector, 1/3 HP 220V 50Hz R404a compressor	15.00
09000337	Condenser fan motor, 220V, 16 watt	140.00
06001398	Automatic defrost timer, 6 hour, 220V, 50 Hz	32.00

FV24 & FV48 COMPRESSOR & CONDENSER RELATED PARTS

11000083	Compressor, 1/5 HP, 220V, 50Hz, R22	\$485.00
11000196	Start capacitor, 1/5 HP 220V/50Hz R22 Tecumseh compressor	15.00
11000198	Relay, 1/5 HP 220V/50Hz R22 Tecumseh compressor	19.50
11000199	Overload protector, 1/5 HP 220V/50Hz R22 Tecumseh compressor	15.00
06001451	Condenser fan motor, 9 watt, 220V 50Hz	125.00
06001398	Automatic defrost timer, 6 hour, 220V, 50 Hz	32.00

VERTICAL DOOR COOLER EVAPORATORS & RELATED PARTS

06001430	Rope lighting, 220V, 50Hz, per foot	9.00
06001318	Rope lighting power cord and connector, 220V European plug style	20.00
06001455	Blower motor, 220V (Endwall BB84, BB108, ND72, ND92, KC52, KC72, KC84)	225.00
06001448	Evaporator fan motor, 220V (Endwall BB36, BB60, ND52, & All Non EW Models)	50.00
06004201	Assembly, shroud, evaporator, 2-fan, 1-2 door e/w, 220 Volt	445.00
06004202	Assembly, shroud, evaporator, 2-fan, 1-2 door e/w, 220 Volt, digital t-stat	600.00

ELECTRICAL COMPONENTS

<u>PART NO.</u>	<u>DESCRIPTION</u>	<u>PRICE</u>
06006121	Replacement powercord assembly, includes (06001572 06001314)	\$40.00

UNPARALLELED UNDERBAR DESIGN & ENGINEERING

Expect more



more flexibility

more features



**Glas
tender**®

Glastender has the most complete line of bar equipment and the ability to manufacture custom units, giving you virtually unlimited design flexibility. Each piece of equipment is engineered with features that enhance your efficiency, ease your maintenance, and prolong the life of your investment.

The flexibility you want. The features you need.

Glastender. Expect more.

GLASSWASHERS • COCKTAIL STATIONS • COOLERS • FROSTERS • BEER SYSTEMS