

Operation Manual and Parts Directory

Glas tender®

ST24, ST36, ST48, ST60, ST72 AND ST96

SLIDE TOP COOLERS

PRIOR TO 2008 ENERGY STAR COMPLIANCE - SEE INSIDE FRONT COVER FOR SN INFORMATION



ST36-B



ST48-SF

Glastender, Inc. · 5400 North Michigan Road · Saginaw, MI · 48604-9780
800.748.0423 · 989.752.4275 · Fax 800.838.0888 / 989.752.4444 · www.glastender.com

<u>TOPIC</u>	<u>PAGE</u>
Terms and Conditions	2
Warranty Statement.....	3
Installation.....	4
Operation.....	4
Cleaning Instructions	5
Electrical and Refrigeration Specifications	5
Wiring Diagrams.....	6-7
ST24 and ST36	6
ST48, ST60, ST72 and ST96	7
Evaporator and related parts	8
Compressor and condenser related parts	9-10
Shelving and related parts.....	11
Doors, tops and related parts	12
Refrigeration compartment covers	13-14
220 Volt electrical parts	14

SLIDE TOP COOLER SERIAL NUMBER INFORMATION

This manual is specific to ST24, ST36, ST48, ST60, ST72, and ST96 coolers produced prior to 2008 Energy Star compliance and prior to the serial numbers and dates listed below.

ST24	134121923N	04/09/09		ST60	134124803N	11/23/09
ST36	134121978N	04/13/09		ST72	134124902N	12/01/09
ST48	134124811N	11/23/09		ST96	134125203N	01/04/10

TERMS AND CONDITIONS

**PRICES:**

All prices are LIST. Applicable taxes will be added.

QUOTATIONS:

Unless otherwise stated, quotations are effective for 30 days only.

ACCEPTANCE:

All orders are subject to acceptance by Glastender, Inc.'s headquarters in Saginaw, Michigan. Possession of the Product Directory and Price List is not an offer to sell.

SHIPMENTS:

F.O.B. factory in Saginaw, Michigan. Freight terms are Third Party or Collect if shipped directly to you. Prepay and Add to Invoice freight terms are available upon request. The approximate shipping weights of all products are listed with the prices. Partial shipments will be made unless otherwise specified by the customer. Surface freight classifications are:

- Glasswashers, Line Chillers - Class 92.5
- Cocktail Stations, Underbar Equipment - Class 85
- Bar Die/Underbar Equipment - Class 125
- Refrigeration Equipment, 48" long or smaller - Class 100
- Refrigeration Equipment, greater than 48" long - Class 110

All small items are evaluated to see the most cost effective means for shipment. Many small items ship via UPS or FedEx; however, when dimensional weight is excessive DB Schenker, UPS Supply Chain, or even common LTL carriers are the most cost effective choice. Spare parts orders received before 1:00 PM EST can usually be shipped the same day.

The order department is happy to assist with routing or shipping questions.

PAYMENT TERMS:

Cash should be included with all orders unless credit terms have been arranged. To establish credit, banking and trade references are required. A convenient credit application is available upon request. Payment via credit card is not our normal means of receiving payment. Visa and MasterCard will be accepted, but must be charged at the time of shipment. In addition, a payment via credit card for orders totaling more than \$500 will incur a 3% convenience fee on the total transaction amount.

DELIVERY:

The majority of equipment is manufactured to order and typically ships within three to six weeks after complete order information is received by the factory. In-stock equipment typically ships within two to three days of the factory receiving complete order information.

RETURNS:

Items specified as "Manufactured to Order" are NOT returnable.

A Return Material Authorization (RMA) number must be issued by the factory in advance for any items that are returnable. The RMA number MUST be noted on the outside of the returned package. Returns must be received within 90 days of the RMA issue date. Shipping charges must be prepaid. A minimum 20% restocking charge will be applied to all authorized returns if received in new, unused condition in the original packaging.

The above conditions apply to spare part returns, except spare part returns must be received within 30 days of original shipment for electronic or electrical parts or within 90 days for all other parts.

LOSS OR DAMAGE:

For customer routed shipments, Glastender, Inc. is not responsible for any loss, damage, or delay of merchandise during shipment. Such transit claims must be filed with the carrier. Merchandise must be examined on arrival. If shortages occur, Glastender, Inc. must be notified in writing within five (5) days of delivery to honor any shortage claim. Glastender will assume responsibility for freight claims on Prepay and Add shipments but the customer must inspect freight and note any damage upon receipt. Failure to do so may result in losses at the customer's expense.

CUSTOM ORDERS:

Custom orders must be paid in advance and are not subject to cancellation.

LAMINATES:

Some products include common, readily available plastic laminates of the customer's selection. There may be an additional charge if uncommon varieties are ordered.

05/18/10

APPLICABLE TO ALL PRODUCTS SOLD WITHIN THE UNITED STATES AND CANADA

LABOR: Glastender, Inc. warrants all products to be free of defects in material and workmanship. In established areas, a start-up and a 90-day labor warranty are included with glasswasher models GT-24 and GT-30. The GT-18 series glasswashers include a 90-day labor warranty. Self-contained refrigeration models, except beer line chillers, include a 1-year labor warranty, for the duration of one year from date of installation or up to 18 months from date of factory shipment, whichever occurs sooner. For warranty labor claims beyond 15 months from the date of factory shipment, proof of date of installation or occupancy must be provided. Authorization for labor must be obtained from Glastender within the warranty period and prior to the service being performed. Labor warranty applies to the United States and Canada only.

PARTS: Within one year from date of installation or 18 months from date of factory shipment, whichever occurs sooner, Glastender, Inc. will replace any part or assembly found defective under normal use and service. Field replacement parts include a warranty of 90 days from date of installation.

FOUR YEAR ADDITIONAL COMPRESSOR WARRANTY: Glastender will warrant to the original user the compressor for all self-contained refrigeration models for an additional four years following the regular one-year warranty period. This plan applies to the compressor only.

A warranty claim form **MUST** accompany all returned defective parts or assemblies. This form **MUST** be completed in full. Failure to do so may result in delay or denial of credit. Any defective part or assembly must be returned to Glastender, Inc., Saginaw, Michigan, with all transportation and delivery charges prepaid. Warranty repairs or replacements will be shipped FOB factory in Saginaw, Michigan. Reimbursement for applicable freight charges covers ground service only.

Glastender provides in-warranty repairs during a service company's regular working days and hours. There is no provision for payment of a premium rate during "overtime" hours. When warranty service is requested during other than normal working hours, the end user will be charged the premium portion of the overtime rate.

The warranty does not cover equipment subjected to accidents, freight damage, alterations from the original design, improper power and/or plumbing hookups, improper chemical use, general misuse, or lack of routine required maintenance as determined by Glastender, Inc. Installation, normal control adjustments, general maintenance, correcting an installation error, or service calls that reveal the unit is functioning normally will not be reimbursed under warranty.

Condenser coils on self-contained refrigeration products must be cleaned regularly. Failure to provide adequate air flow to a refrigeration unit will void the warranty.

Glastender shall not be liable for loss of use, revenue, or profit, or for any other indirect, incidental, special, or consequential damage including, but not limited to, product spoilage or loss.

This warranty is conditioned upon Glastender receiving notice of any defect subject to this warranty within sixty (60) days of its discovery by the end user or dealer. All products are warranted only for the initial place of installation. Removal of a product automatically terminates this warranty.

SECOND YEAR EXTENDED PARTS & LABOR WARRANTY: Glastender's one-year parts and labor warranty on self-contained refrigeration units, excluding beer line chillers, can be extended to two years with the purchase of a two year parts and labor warranty. Specify part number EWR2 (\$150 net price) when ordering.

EXPORT WARRANTY - One year parts only.

EXCLUSION OF WARRANTIES
EXCEPT AS PROVIDED ABOVE, GLASTENDER MAKES NO WARRANTIES, EXPRESS OR IMPLIED, INCLUDING, BUT NOT LIMITED TO, ANY IMPLIED WARRANTY OF MERCHANTABILITY, FITNESS FOR A PARTICULAR PURPOSE OR NON-INFRINGEMENT.

LIMITATION OF REMEDIES AND DAMAGES
If Buyer makes a valid and timely claim as outlined above, Glastender's liability and Buyer's remedies under this agreement will be limited solely to labor charges authorized and/or replacement or credit, at Glastender's option, with respect to Products returned at Buyer's expense within thirty (30) days after warranty repair. GLASTENDER'S LIABILITY WILL IN NO EVENT BE GREATER IN AMOUNT THAN THE PURCHASE PRICE OF THE RETURNED PRODUCTS. GLASTENDER WILL NOT BE LIABLE UNDER ANY CIRCUMSTANCE FOR CONSEQUENTIAL OR INCIDENTAL DAMAGES, INCLUDING, BUT NOT LIMITED TO, LABOR COSTS EXCEPT AS COVERED UNDER OUR WARRANTY, LOST PROFITS OR THE LOSS OF PERISHABLE PRODUCTS RESULTING FROM THE USE OF OR INABILITY TO USE OUR PRODUCTS OR FROM OUR PRODUCTS' INCORPORATION INTO OR BECOMING A COMPONENT OF ANY OTHER PRODUCT. NEITHER PARTY WILL HAVE ANY NEGLIGENCE OR OTHER TORT LIABILITY TO THE OTHER, OR TO ANY THIRD PARTY, ARISING FROM ANY BREACH OF THIS AGREEMENT.

GOVERNING LAW - JURISDICTION

The terms and conditions of an order are to be governed and construed according to the laws of the State of Michigan, without regard to conflict of laws principles. Buyer hereby consents to the jurisdiction and venue of the courts located in Saginaw County, Michigan.

No representative, distributor, dealer, or any other person is authorized to modify this warranty. This warranty replaces all other written or verbal warranties.

NOTE: Glastender, Inc.'s policy of constant quality improvement means that prices, specifications, and policies are subject to change without notice. Questions regarding this warranty should be directed to Glastender's Customer Service Representative.

03/03/10

IMPORTANT!!

Attention Refrigeration Service Companies

Please review the important warranty information on this page. If you believe a service call should be covered by the factory, please call the factory for authorization between 8AM and 5PM EST, Monday through Friday.

INTRODUCTION

This manual describes the operational features of Slide Top Coolers. Please review this information before attempting installation and operation.

Long term, trouble-free service will follow if good housekeeping and maintenance procedures are followed. Thank you for selecting Glastender, Inc. products.

UTILITY REQUIREMENTS AND CONNECTIONS

- *Electrical:* 115 Volt AC, 1 Phase, 60 Hz. A separate 15 Amp circuit is recommended. A 6-foot grounded cord is included.
- *Plumbing:* None required. Automatic condensate evaporator is included.

UNCRATING AND START-UP INSTRUCTIONS

All Slide Top Cooler models are shipped in one carton. These steps should be followed:

1. If legs or casters are included, bolt them to the base with the bolts provided.
2. Unwrap power cord from base.
3. Position unit and level and/or seal as required (see page 1-2).
4. Place racks in desired location.
5. Plug into 115 volt AC outlet.
6. Load with bottles or cans and allow time to cool. For best performance, load with pre-cooled bottles or cans. It is recommended that back-up product be stored in a walk-in cooler.
7. Your Glastender equipment is now ready for use.

SEALING SLIDE TOP BASE TO FLOOR

To comply with NSF & health codes. The slide top base must be sealed to the floor using NSF listed sealant. Place bead of sealant along outer edges of the base and remove excess with disposable towel.



OPERATION

The Slide Top Cooler is designed to maintain bottles and cans at an operating temperature range of 36°F (2°C) to 40°F (5°C).

Slide Top Coolers include an automatic defrost system. The cooler will defrost every six hours for approximately 20 minutes. During the defrost, the fan inside the cooler will remain on and the refrigeration system will turn off.

CLEANING INSTRUCTIONS

Cleaning is essential to sustaining the integrity of your equipment and preventing corrosion.

ESTIMATED CLEANING TIME: 5 to 10 minutes per unit daily, 45 minutes quarterly

FREQUENCY: Daily cleaning of exterior & door gaskets. Quarterly cleaning of interior, including shelves.

PROCEDURE:

1. A non-chlorine based cleaner or mild detergent and warm water applied with a soft cloth or sponge to all contact surfaces.
2. Immediately rinse off cleaning agent(s), using clean warm water, clean soft cloth or sponge.
3. Dry with a soft clean cloth, removing standing water as soon as possible.

NOTES:

1. Never use hydrochloric acid, wire brushes, steel wool, scrapers, or chlorine based cleaners on stainless steel surfaces, since they will break down the passivity layer and allow corrosion to occur.
2. On stainless steel surfaces, you may use a soft bristle brush or Scotch-Brite® pad for more stubborn stains. Always scrub with the direction of the grain. Follow with a thorough cleaning as described above.
3. Deposits from food preparation must be properly removed. Even hard water deposits will rust stainless steel, if not removed.
4. Repeated cleaning may dry up black-vinyl-clad steel (exterior) surfaces of the cooler. Armor All® or similar product can bring back the shine. Apply the product to a cloth and then rub into the surface, rather than spraying it directly onto the black-vinyl-clad surface.
5. The cooler door gaskets are most often overlooked when cleaning. Failure to clean them regularly will lead to premature failure, since alcohol and moisture build-up breaks down the gasket material.
6. A slide top cooler does not have an interior drain, so a large sponge is required for removing excess moisture from the interior after cleaning.

ELECTRICAL AND REFRIGERATION SPECIFICATIONS

MODEL (L-to-R LENGTH)	ELECTRICAL	REFRIGERANT		DESIGN PRESSURE	
		TYPE	CHARGE	HIGH	LOW
24"	115V, 1Ph., 60 Hz., 5 Amp	R22	13.5oz.	200	85
36"	115V, 1Ph., 60 Hz., 5 Amp	R22	13.5oz.	200	85
48"	115V, 1Ph., 60 Hz., 8 Amp	R22	13.5oz.	285	144
60"	115V, 1Ph., 60 Hz., 8 Amp	R22	13.5oz.	285	144
72"	115V, 1Ph., 60 Hz., 8 Amp	R22	13.5oz.	285	144
96"	115V, 1Ph., 60 Hz., 8 Amp	R22	13.5oz.	285	144

WIRING DIAGRAM FOR MODELS ST24 AND ST36

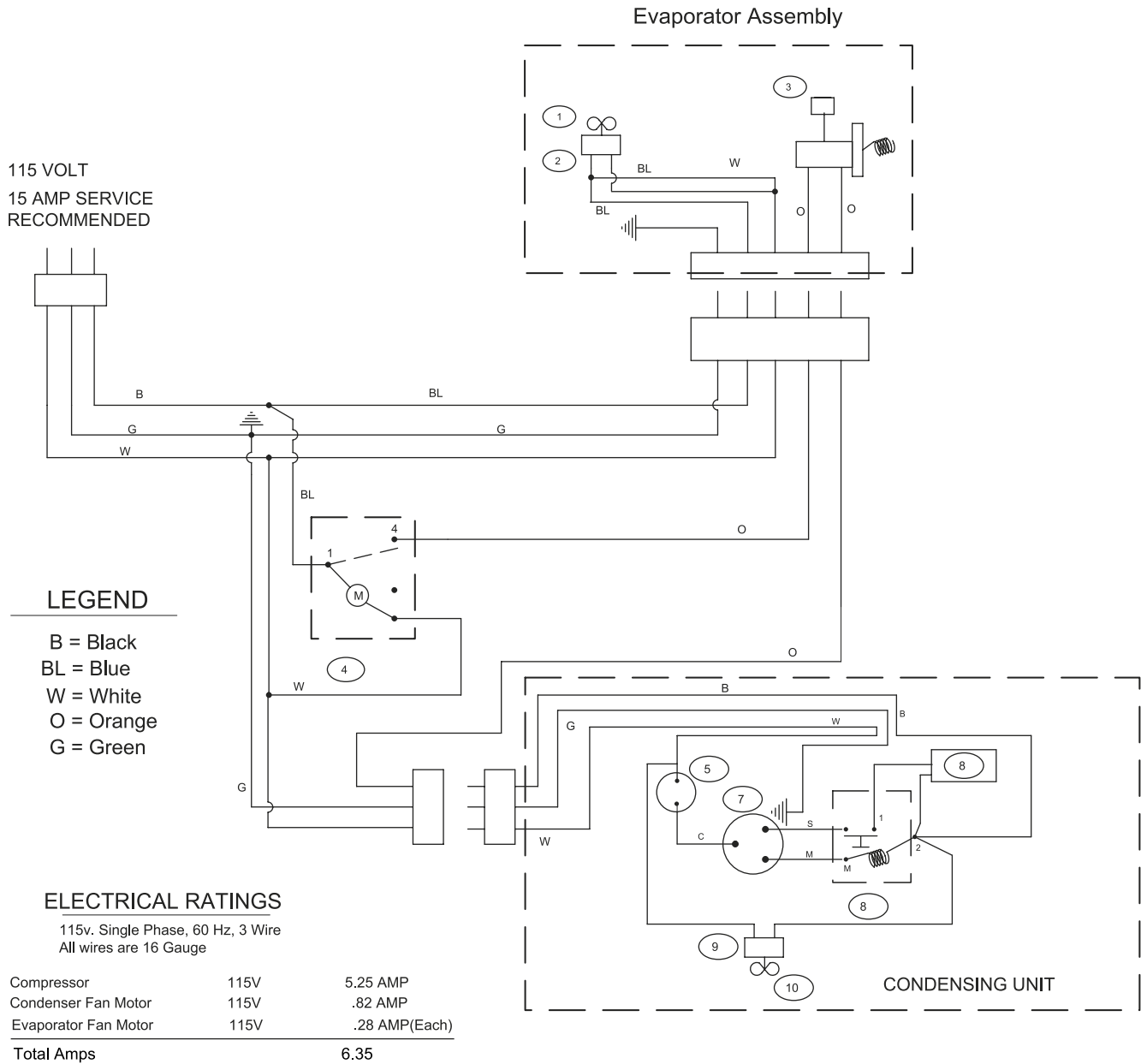

ITEM	DESCRIPTION	PART #
1	EVAPORATOR FAN BLADE	06001395
2	EVAPORATOR FAN MOTOR	06001445
3	THERMOSTAT	06001405
4	DEFROST TIMER	06001397
5	OVERLOAD	06001303
6	CAPACITOR	06001382
7	COMPRESSOR, 1/5 HP, R22	06001444
8	START RELAY	06001415
9	CONDENSER FAN MOTOR	09000336
10	CONDENSER FAN BLADE	07000155

Evaporator Assembly

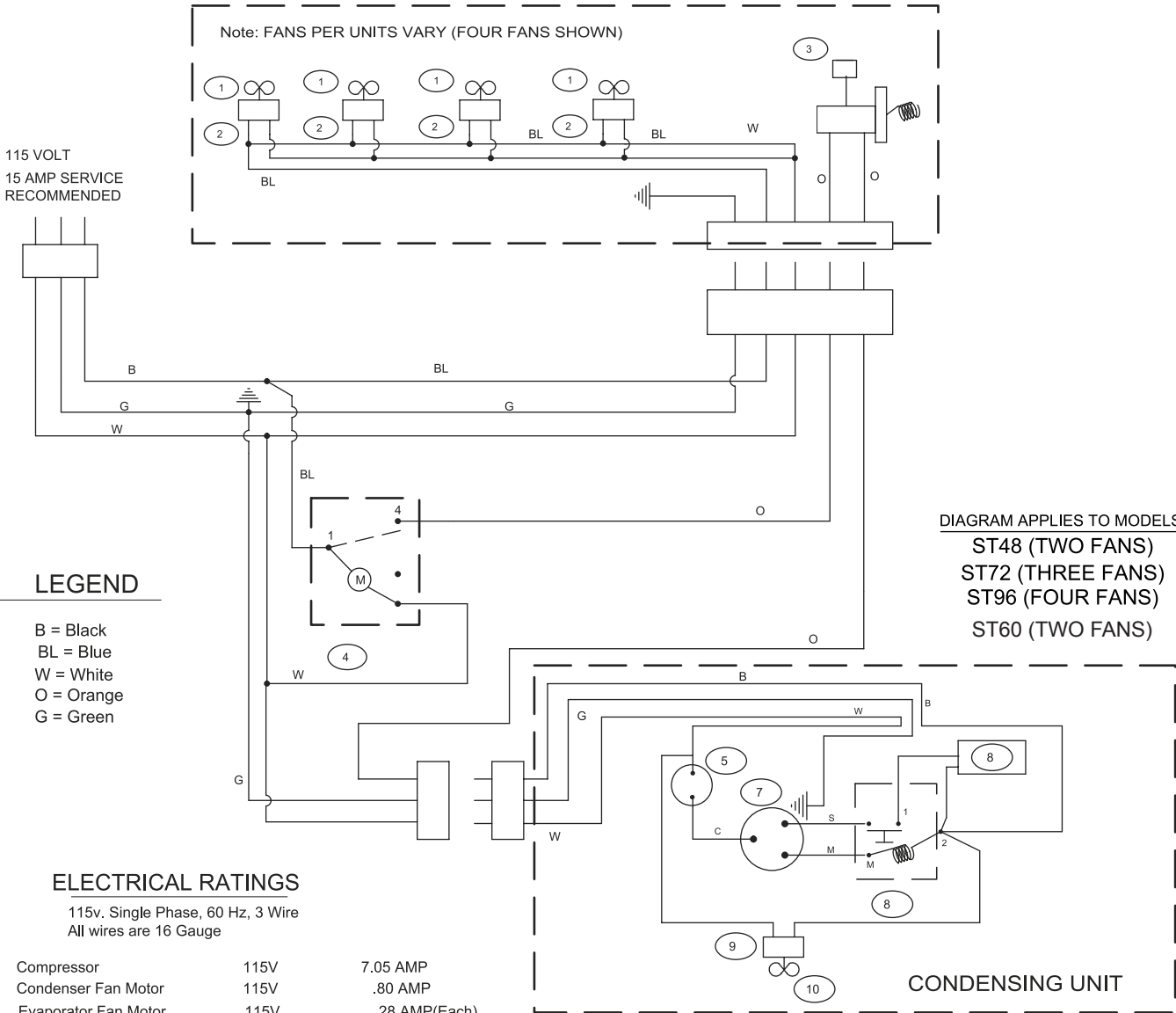

ITEM	DESCRIPTION	PART #
1	EVAPORATOR FAN BLADE	06001395
2	EVAPORATOR FAN MOTOR	06001445
3	THERMOSTAT	06001405
4	DEFROST TIMER	06001397
5	OVERLOAD	07000128
6	CAPACITOR	06001380
7	COMPRESSOR, 1/3 HP, R22	06001443
8	START RELAY	07000168
9	CONDENSER FAN MOTOR	08000085
10	CONDENSER FAN BLADE	08000081

EVAPORATOR AND RELATED PARTS



PART NO.	OLD PART NO.	DESCRIPTION	PRICE
1. 07000310	GT-031514	Bracket, evaporator fan motor	\$14.00
2. 06001383	GT-032301	Guard, evaporator fan	12.00
3. 06001395	GT-032802	Fan blade, evaporator, 5 blade	5.00
4. 06001445	GT-035107	Fan motor, evaporator	35.00
5. 06001405	GT-033202	Temperature control, includes knob	50.00
6. 06001632	GT-038419	Knob, temperature control	3.00
7. 08000079	GT-032609	Evaporator coil, ST24, 36	180.00
08000077	GT-032604	Evaporator coil, ST48, 60	285.00
08000080	GT-032610	Evaporator coil, ST72, 96	390.00
8. 08000092	GT-036121	Cover, front, evaporator, stainless steel, ST24, 36	85.00
08000093	GT-036122	Cover, front, evaporator, stainless steel, ST48	108.00
08000147		Cover, front, evaporator, stainless steel, ST60	132.00
08000094	GT-036123	Cover, front, evaporator, stainless steel, ST72	162.00
08000095	GT-036124	Cover, front, evaporator, stainless steel, ST96	210.00
08000096	GT-036125	Cover, front, evaporator, galvanized, ST24, 36	66.00
08000097	GT-036126	Cover, front, evaporator, galvanized, ST48	77.00
08000211		Cover, front, evaporator, galvanized, ST60	100.00
08000098	GT-036127	Cover, front, evaporator, galvanized, ST72	120.00
08000099	GT-036128	Cover, front, evaporator, galvanized, ST96	170.00
9. 07000229	GT-037421	Housing and drain pan, evaporator, ST24, 36	60.00
08000116	GT-037422	Housing and drain pan, evaporator, ST48	72.00
08000139		Housing and drain pan, evaporator, ST60	84.00
08000117	GT-037423	Housing and drain pan, evaporator, ST72	96.00
08000118	GT-037424	Housing and drain pan, evaporator, ST96	120.00
10. 06001345	GT-031716	Tubing, drain, clear plastic, 1/2" ID x 5/8" OD per ft.	1.45

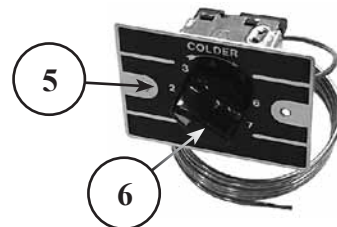
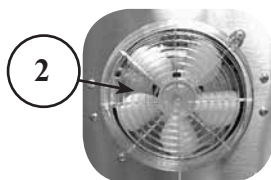
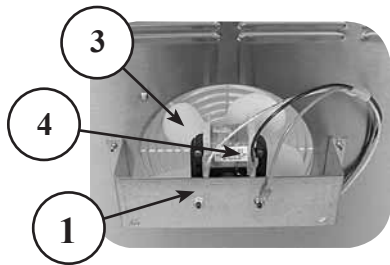

(Temperature control is located behind the front cover on the ST24,36)

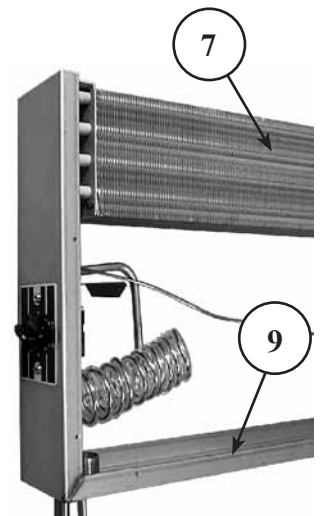
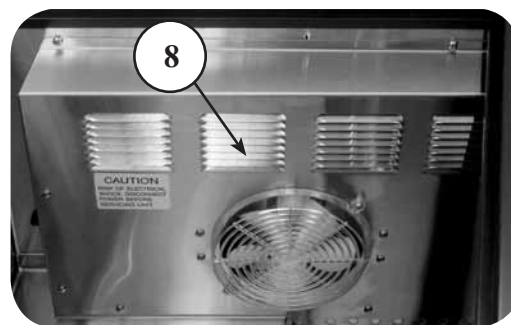
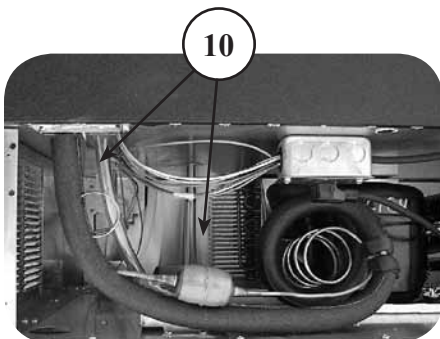

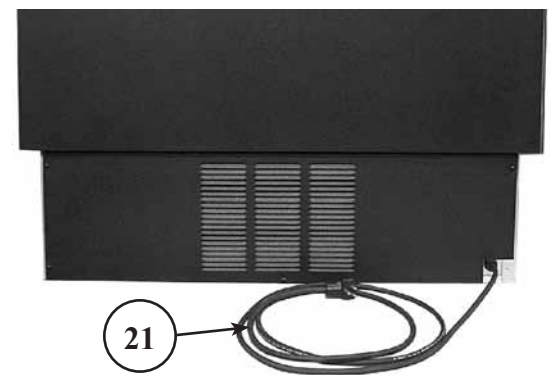
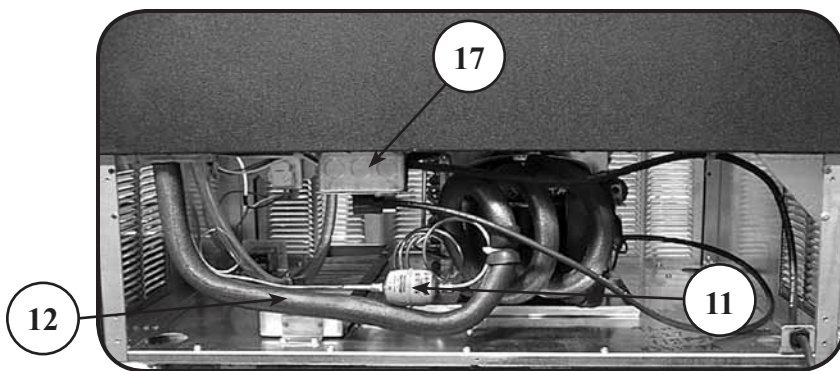
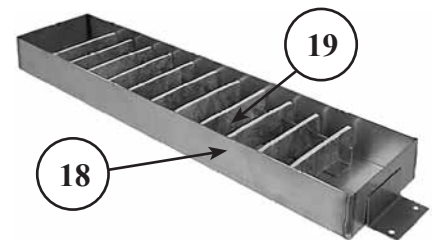
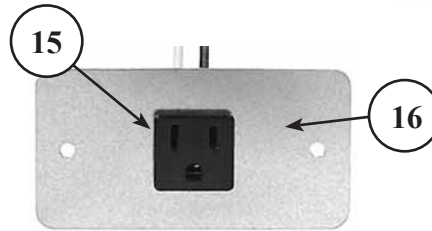
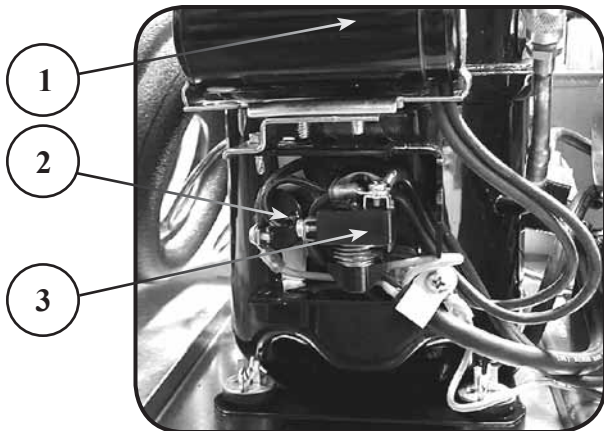
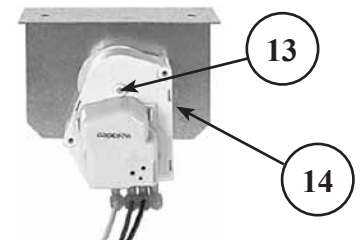
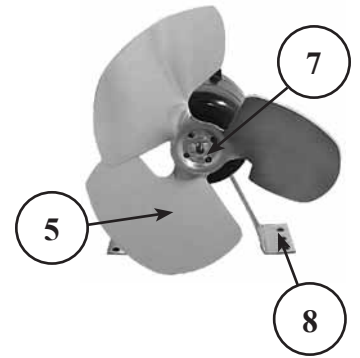
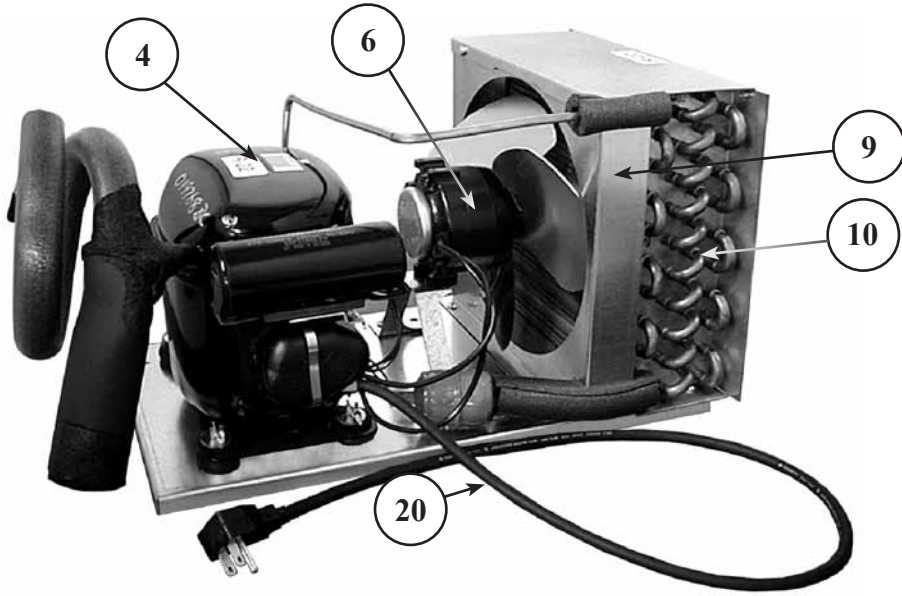

Rear view of ST36

COMPRESSOR AND CONDENSER RELATED PARTS



<u>PART NO.</u>	<u>OLD PART NO.</u>	<u>DESCRIPTION</u>	<u>PRICE</u>
07000172	GT-035002	1/3 HP Aspera compressor, R22, ST48, 72, 96 (includes: 08000068, 06001379, and 06001414)	\$500.00
1. 06001379	GT-032201	Start capacitor, 1/3 and 1/5 HP Aspera compressor	20.00
2. 08000068	GT-031202	Overload protector, 1/3 HP Aspera compressor, ST48, 72, 96	12.00
3. 06001414	GT-034103	Relay, 1/3 HP Aspera compressor, ST48, 72, 96	14.00
11000082	GT-035005	1/5 HP Aspera compressor, R22, ST24, 36 (includes: 08000069, 06001379, and 08000083)	535.00
08000069	GT-031204	Overload protector for 1/5 HP Aspera compressor, ST24, 36	15.00
08000083	GT-034107	Relay for 1/5 HP Aspera compressor, ST24, 36	15.00
4. 06001443	GT-035025	1/3 HP Tecumseh compressor, R22, ST48, 60, 72, 96 (includes: 06001380, 07000168, and 07000128)	400.00
06001380	GT-032206	Start capacitor for 1/3 HP Tecumseh compressor	20.00
07000168	GT-034112	Relay, 1/3 HP Tecumseh compressor, ST48, 60, 72, 96	18.00
07000128	GT-031207	Overload protector for 1/3 HP Tecumseh compressor, ST48, 60, 72, 96	12.00
06001444	GT-035027	1/5 HP Tecumseh compressor, R22, ST24, 36 (includes: 06001382, 06001415, and 06001303)	490.00
06001382	GT-032207	Start capacitor for 1/5 HP Tecumseh compressor	15.00
04000243	GT-034113	Relay for 1/5 HP compressor, ST24, 36	18.00
06001303	GT-031208	Overload protector for 1/5 HP compressor, ST24, 36	10.00
5. 08000081	GT-032801	Fan blade, condenser, 3 blade, ST48, 60, 72, 96	13.00
07000155	GT-032803	Fan blade, condenser, 5 blade, ST24, 36	10.00
6. 08000085	GT-035106	Motor, condenser fan, 16W, ST48, 60, 72, 96	110.00
09000336	GT-035109	Motor, condenser fan, 9W, ST24, 36	80.00
7. 07000179	GT-035714	Nut, fan blade mounting	1.00
8. 06001319	GT-031512	Bracket, condenser fan motor mounting, ST48, 60, 72, 96	5.00
06001321	GT-031515	Bracket, condenser fan motor mounting, ST24, 36	5.00
9. 08000075	GT-032307	Fan shroud, condenser, ST48, 60, 72, 96	11.00
07000152	GT-032302	Fan shroud, condenser, ST24, 36	15.00
10. 08000076	GT-032601	Condenser coil, ST48, 60, 72, 96	220.00
08000078	GT-032607	Condenser coil, ST24, 36	145.00
11. 06001385		Filter dryer, 1/4" x 1/4"	20.00
08000126	GT-031717	Capillary tubing, 38" x .036 ID, ST24, 36	20.00
06001614	GT-032510	Capillary tubing, 110" x .054 ID, ST48, 60, 72, 96	20.00
06001633	GT-032512	Capillary tubing, 48" x .054 ID (set of two), ST96, dual evaporator	20.00
12. 06001354	GT-031749	Tubing, armaflex, 1-1/8" ID x 3/8" OD (per foot)	2.00
13. 06001397	GT-033000	Defrost timer, automatic	32.00
14. 07000138	GT-031542	Bracket, automatic defrost timer mounting	3.00
00000051	GT-038773	Screw, automatic defrost timer mounting, #6 x 1/2" PPH, SMS, zinc	1.00
15. 06001409	GT-033304	Receptacle, compressor	5.00
16. 06000011	GT-036148	Cover, compressor receptacle mounting	10.00
00000030	GT-038728	Screw, electrical box and compressor receptacle mounting, #10 x 1/2", PPH, zinc, drll kwik (4 required)	1.00
17. 00000168	GT-040729	Electrical box	4.00
06001552	GT-038401	Grommet, electrical box (2 required)	3.50
18. 08000125	GT-038006	Pan, condensate, ST24, 36	60.00
08000119	GT-038007	Pan, condensate, ST48, 60, 72, 96	115.00
19. 07000235	GT-038203	Wicking material, consists of 11 4" pieces, ST24, 36 (prior to 1998)	14.00
07000234	GT-038204	Wicking material, consists of 11 9-1/4" pieces, ST48, 72, 96 (prior to 1998)	24.00
08000128		Wicking material, consists of 20 4" pieces, ST24, 36 (after 1998)	32.00
08000129		Wicking material, consists of 30 9-1/4" pieces, ST48, 60, 72, 96 (after 1998)	50.00
20. 06001313	GT-031400	Power cord, condensing unit	20.00
21. 06001314	GT-031401	Power cord, exterior	35.00

SHELVING AND RELATED PARTS

<u>PART NO.</u>	<u>OLD PART NO.</u>	<u>DESCRIPTION</u>	<u>PRICE</u>
1. 08000071	GT-031529	Bracket, 28" divider rack, ST48 (2 required)	\$20.00
08000137		Bracket, 40", divider rack, ST60 (2 required)	26.00
08000072	GT-031530	Bracket, 52" divider rack, ST72 (2 required)	30.00
08000073	GT-031531	Bracket, 76" divider rack, ST96 (2 required)	40.00
00000031	GT-038729	Screw, bracket mounting, #10 x 1/2" PPH, SS, SMS	1.00
2. 08000082	GT-032906	Rack, divider, chrome, ST48, 60, 72, 96	50.00
3. 08000114	GT-037206	Divider wall, stainless steel, ST24, 36	60.00
08000115	GT-037207	Divider wall, galvanized, ST24, 36	41.00



2

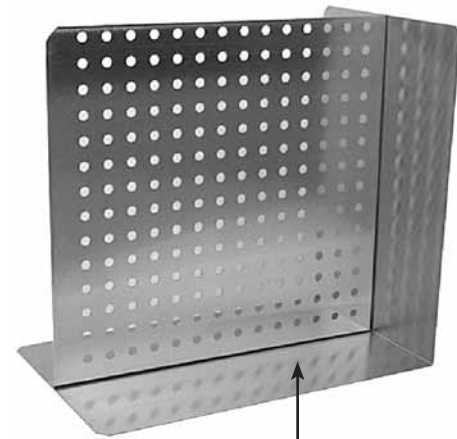

3

LIGHT KITS

<u>PART NO.</u>	<u>DESCRIPTION</u>	<u>PRICE</u>
1. STLK-1	Light kit, ST48, ST60	\$140.00
STLK-2	Light kit, ST72, ST96	280.00



1

DOORS, TOPS, AND RELATED PARTS



<u>PART NO.</u>	<u>OLD PART NO.</u>	<u>DESCRIPTION</u>	<u>PRICE</u>
1. 07000129	GT-031311	Gasket, wiper, 24" top 21-1/2" long	\$10.00
07000130	GT-031312	Gasket, wiper, 36" top 33-1/2" long	14.00
08000107	GT-036221	Sliding door, locking, 20-3/16", ST24	180.00
08000108	GT-036222	Sliding door, locking, 32-3/16", ST36	240.00
08000106	GT-036217	Sliding door, locking ST24, ST48, ST72, ST96 (pre 2000)	180.00
08000109	GT-036223	Sliding door, locking, ST36 (pre 2000)	240.00
07000213	GT-036214	Sliding door, 20-3/16", ST24	126.00
2. 07000214	GT-036216	Sliding door, 32-3/16", ST36	192.00
08000225		Key, CH751 for slide top cooler lock	4.00
07000544		Key, AH2 for slide top cooler lock (06-07 through 08-01-07)	4.00
3. 07000231	GT-038113	Top, ST24	126.00
07000232	GT-038114	Top, ST36	192.00
07000233	GT-038115	Top, ST48	252.00
08000184		Top, ST60	360.00
08000120	GT-038116	Top, ST72	384.00
08000121	GT-038117	Top, ST96	510.00
4. 07000250	GT-040306	Breaker strip, 24" sliding locking door opening, 4 pieces	70.00
07000251	GT-040307	Breaker strip, 36" sliding locking door opening, 4 pieces	80.00
07000238	GT-038437	Breaker strip, 24" sliding door opening, 4 pieces	25.00
07000239	GT-038438	Breaker strip, 36" sliding door opening, 4 pieces	35.00

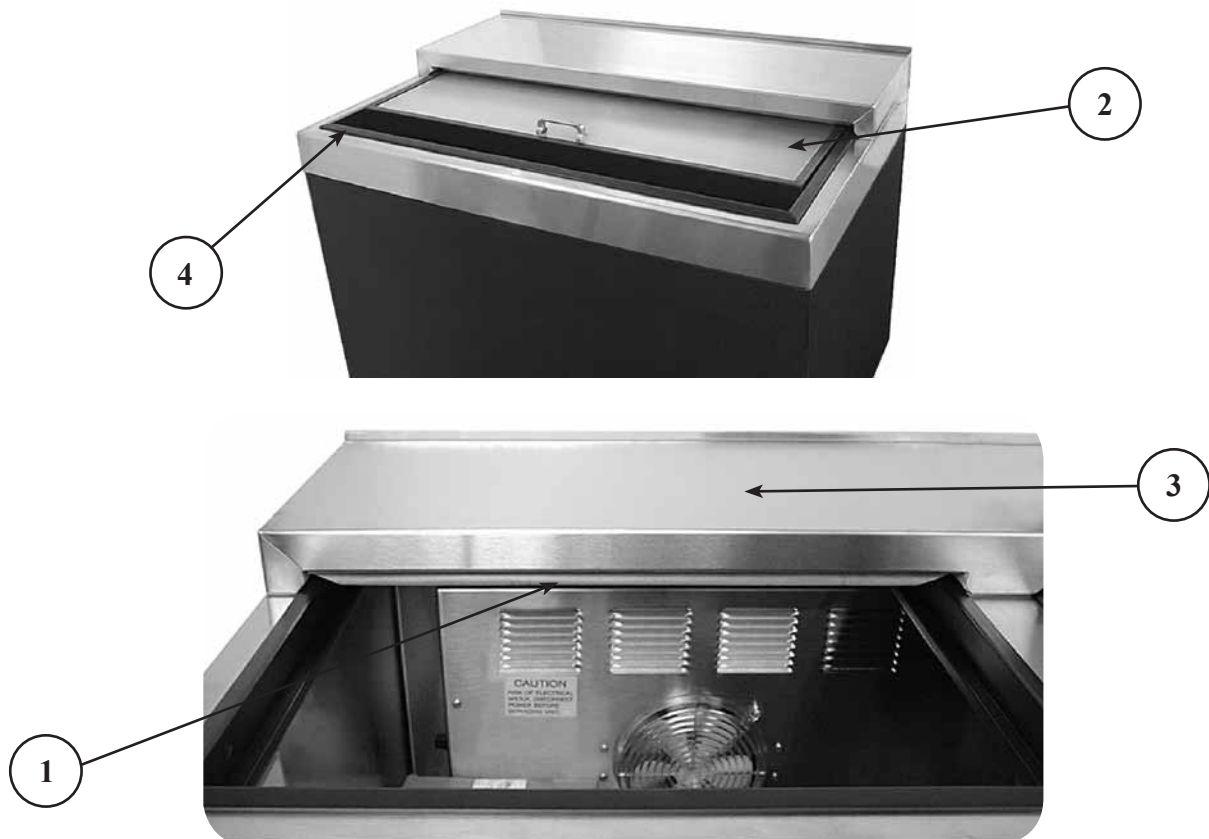

Left Side from rear

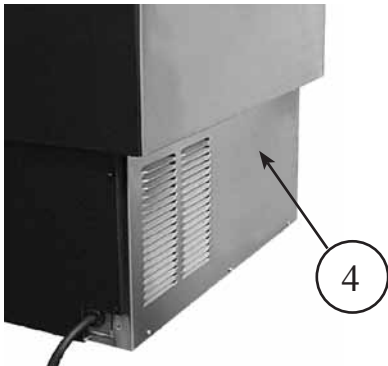

Right Side from rear

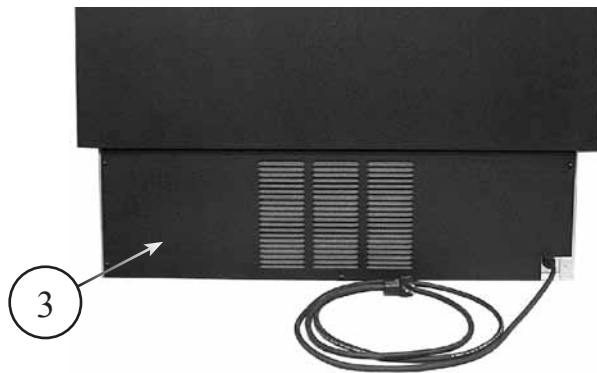
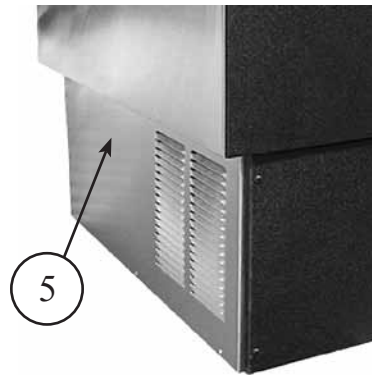

Models ST24, ST36

Rear view

Front view

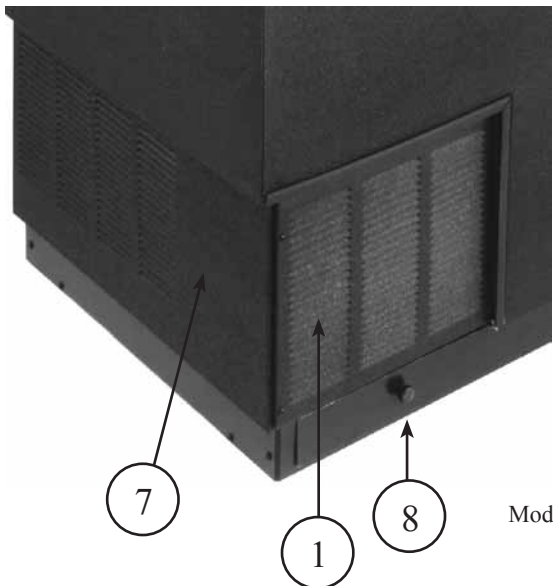

Models ST48, ST60, ST72, and ST96

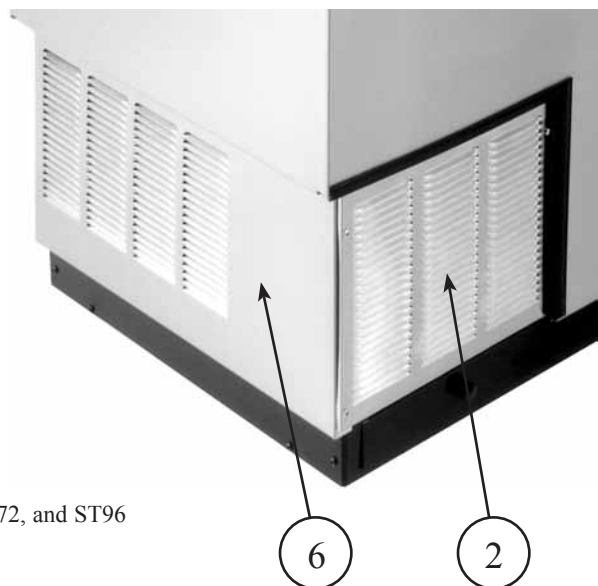

REFRIGERATION COMPARTMENT COVERS



<u>PART No.</u>	<u>OLD PART No.</u>	<u>DESCRIPTION</u>	<u>PRICE</u>
07000202	GT-036129	Cover, front, black clad vinyl, ST24	\$40.00
07000203	GT-036130	Cover, front, stainless steel, ST24	80.00
08000100	GT-036131	Cover, front, black clad vinyl, ST36	50.00
08000101	GT-036132	Cover, front, stainless steel, ST36	100.00
1. 08000102	GT-036133	Cover, front or back, black clad vinyl, ST48, 60, 72, 96	50.00
2. 08000103	GT-036134	Cover, front or back, stainless steel, ST48, 60, 72, 96	100.00
3. 07000192	GT-036111	Back, black clad vinyl, ST24	40.00
07000193	GT-036112	Back, stainless steel, ST24	80.00
07000194	GT-036113	Back, black clad vinyl, ST36	50.00
07000195	GT-036114	Back, stainless steel, ST36	100.00
07000198	GT-036117	Side, left, black clad vinyl, ST24, 36	40.00
4. 07000199	GT-036118	Side, left, stainless steel, ST24, 36	80.00
07000200	GT-036119	Side, right, black clad vinyl, ST24, 36	40.00
5. 07000201	GT-036120	Side, right, stainless steel, ST24, 36	80.00
6. 08000105	GT-036140	Side, left, stainless steel, ST48, 60, 72, 96	80.00
7. 08000104	GT-036139	Side, left, black clad vinyl, ST48, 60, 72, 96	40.00
8. 08000119	GT-038007	Pan, condensate, ST48, 60, 72, 96	115.00

220 VOLT ELECTRICAL PARTS

<u>PART No.</u>	<u>DESCRIPTION</u>	<u>PRICE</u>
06001436	Compressor, 1/3 HP, 220/50Hz, R22, ST48, 60, 72, 96	\$500.00
06001793	Start capacitor, for 1/3 HP R404A and R22 compressor, 220/50Hz	25.00
06004146	Relay, compressor, 1/3 HP, 220V/50Hz, R22, ST48, 60, 72, 96	15.00
06004147	Overload for 1/3 HP R22 compressor, 220/50Hz, ST48, 60, 72, 96	15.00
11000083	Compressor, 1/5HP, 220V, 50Hz, R22, ST24, 36	485.00
11000196	Start capacitor, 1/5HP R22 compressor 220/50Hz, ST24, 36	15.00
11000198	Relay, 1/5HP, R22 compressor 220V/50Hz, ST24, 36	19.50
11000199	Overload protector, 1/5HP, R22, compressor 220V/50Hz, ST24, 36	15.00
09000337	Motor, condenser fan, 220V, 16 watt, ST48, 60, 72, 96	140.00
06001451	Motor, condenser fan, 9 watt, 220V 50/60 Hz, ST24, 36	120.00
06001448	Motor, evaporator fan, 220V	50.00
06001398	Defrost timer, automatic, 220V, 50 cycle	32.00

ELECTRICAL COMPONENTS

<u>PART No.</u>	<u>DESCRIPTION</u>	<u>PRICE</u>
06006121	Replacement powercord assembly, includes (06001572 06001314)	\$40.00

