



**CTB/CTBR SERIES**  
**ELECTRIC CONVECTION OVEN**  
**INSTALLATION – OPERATION – MAINTENANCE**



**BLODGETT OVEN COMPANY**

[www.blodgett.com](http://www.blodgett.com)

44 Lakeside Avenue, Burlington, Vermont 05401 USA Telephone (800) 331-5842, (802) 860-3700 Fax: (802)864-0183

PN 11361 Rev J (1/03)

© 2003 – G.S. Blodgett Corporation

# IMPORTANT

**WARNING: IMPROPER INSTALLATION, ADJUSTMENT, ALTERATION, SERVICE OR MAINTENANCE CAN CAUSE PROPERTY DAMAGE, INJURY OR DEATH. READ THE INSTALLATION, OPERATING AND MAINTENANCE INSTRUCTIONS THOROUGHLY BEFORE INSTALLING OR SERVICING THIS EQUIPMENT**

## **FOR YOUR SAFETY**

**Do not store or use gasoline or other flammable vapors or liquids in the vicinity of this or any other appliance.**

**The information contained in this manual is important for the proper installation, use, and maintenance of this oven. Adherence to these procedures and instructions will result in satisfactory baking results and long, trouble free service. Please read this manual carefully and retain it for future reference.**

**Errors: Descriptive, typographic or pictorial errors are subject to correction. Specifications are subject to change without notice.**



***THE REPUTATION YOU CAN COUNT ON***

For over a century and a half, The Blodgett Oven Company has been building ovens and nothing but ovens. We've set the industry's quality standard for all kinds of ovens for every foodservice operation regardless of size, application or budget. In fact, no one offers more models, sizes, and oven applications than Blodgett; gas and electric, full-size, half-size, countertop and deck, convection, Cook'n Hold, Combi-Ovens and the industry's highest quality Pizza Oven line. For more information on the full line of Blodgett ovens contact your Blodgett representative.

Your Service Agency's Address:



Model:

---

Serial Number:

---

Your oven was installed by:

---

Your oven's installation was checked by:

---

# Table of Contents

---

## **Introduction**

Oven Description and Specifications .....	2
Oven Components .....	3

## **Installation**

Delivery and Location .....	4
Stand Assembly .....	5
Stand Options .....	5
Stand Assembly .....	5
Oven Assembly .....	7
Oven Assembly to Stand .....	7
4" (10cm) Leg Attachment .....	8
Caster Installation .....	8
Oven Leveling .....	8
Adjustments Associated with Initial Installation .....	8
Utility Connections – Standards and Codes .....	9
Electrical Connection .....	10

## **Operation**

Safety Information .....	11
Solid State Manual .....	12
Solid State Digital .....	13
Fan Delay and Pulse Plus Control .....	15
Cook and Hold .....	16
CH-Pro3 (Solid State Programmable Digital Control) .....	18
Blodgett IQ2™ Control .....	21
How Cook and Hold Works .....	30
General Guidelines for Operating Personnel .....	31
Suggested Times and Temperatures .....	32

## **Maintenance**

Cleaning and Preventative Maintenance .....	33
Troubleshooting Guide .....	34



# Introduction

## Oven Description and Specifications

Cooking in a convection oven differs from cooking in a conventional deck or range oven since heated air is constantly recirculated over the product by a fan in an enclosed chamber. The moving air continually strips away the layer of cool air surrounding the product, quickly allowing the heat to penetrate. The result is a high quality product, cooked at a lower temperature in a shorter amount of time.

Blodgett convection ovens represent the latest advancement in energy efficiency, reliability, and ease of operation. Heat normally lost, is recirculated within the cooking chamber before being vented from the oven: resulting in substantial reductions in energy consumption and enhanced oven performance.

KW/Section	Volts	Phase	Amperes				Electrical Connection AWG*
			L1	L2	L3	N	
<b>60 HZ UNITS</b>							
5.6	208	1	27	–	27	–	8
5.6	208	3	24	12	15	–	10
5.6	220-240	1	24	–	24	–	8
5.6	220-240	3	21	11	14	–	10
8.0	208	1	35	–	35	–	6
8.0	208	3	22	20	21	–	10
8.0	220-240	1	32	–	32	–	6
8.0	220-240	3	20	18	19	–	10
<b>50 HZ UNITS</b>							
5.6	208	1	27	–	27	–	Size per local codes
5.6	220–240	1	24	–	–	24	
8	220–240	1	35	–	–	35	
5.6	220/380	3	10	8	8	2	
8	220/380	3	14	12	12	2	
5.6	240/415	3	10	7	7	3	
8	240/415	3	13	11	11	2	
5.6	230/400	3	9	8	8	1	
8	230/400	3	13	11	11	2	

**NOTE:** \*Electric connection wiring is sized for 90°C copper wire at 125% of rated input. Refer to Page 10 in this manual for Electrical Connection specifications.

**NOTE:** Double units can have phase loads partially equalized by matching lines during hook-up. Otherwise, CTB-Double or CTBR-Double load ratings are twice the above data.



## Oven Components

**Heating Elements** – located on the side of the oven, the elements provide heat to the baking chamber on electric ovens.

**Control Panel** – contains wiring and components to control the oven operation.

**Oven Racks** – five racks are provided standard. Additional racks are available.

**Rack Supports** – hold oven racks.

**Blower Wheel Cover** – located on the side interior wall of the oven. Protects the blower wheel.

**Blower Wheel** – spins to circulate hot air in the baking chamber.

**Convection Motor** – provides power to turn the blower wheel.

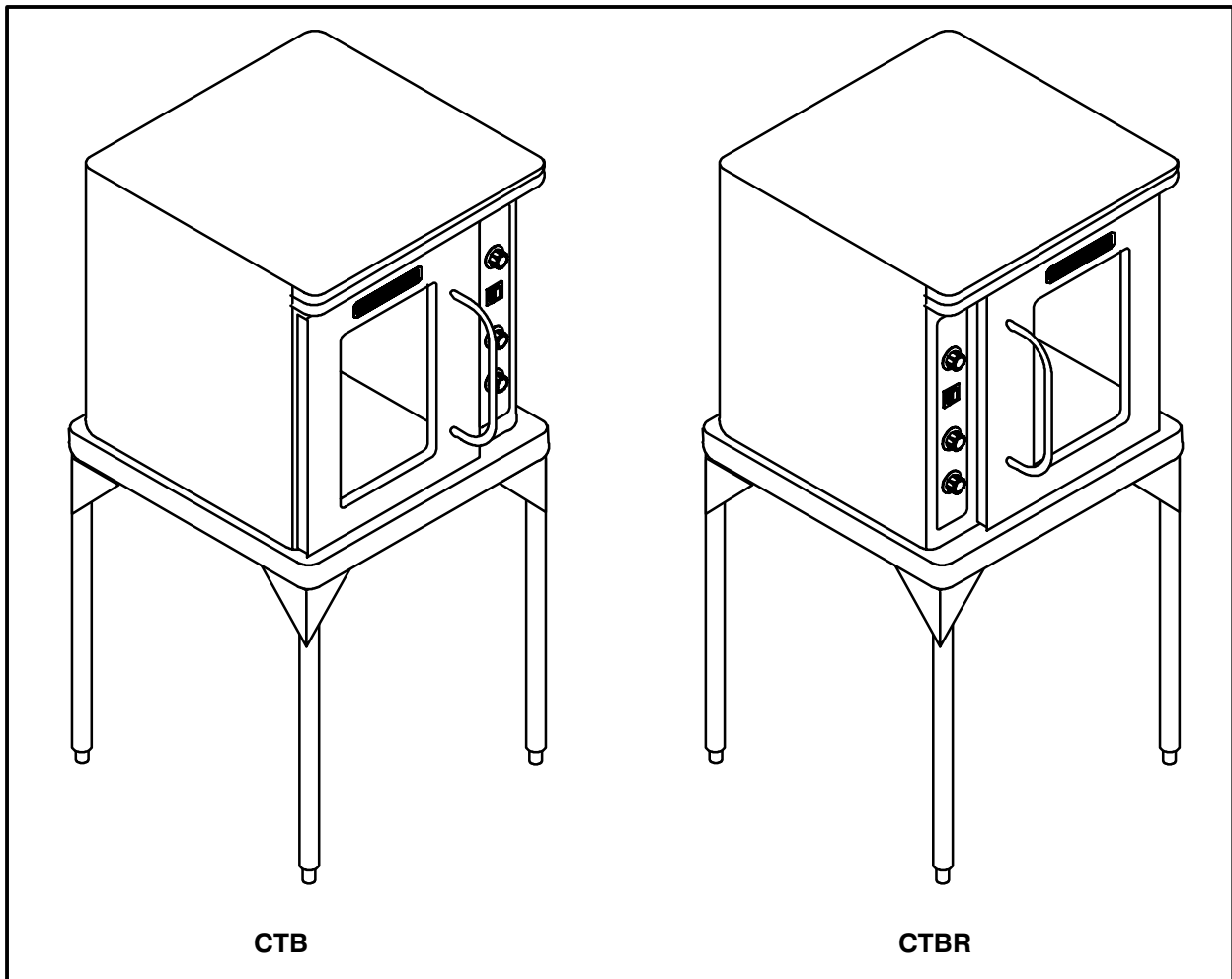

Figure 1



# Installation

## Delivery and Location

### DELIVERY AND INSPECTION

All Blodgett ovens are shipped in containers to prevent damage. Upon delivery of your new oven:

- Inspect the shipping container for external damage. Any evidence of damage should be noted on the delivery receipt which must be signed by the driver.
- Uncrate the oven and check for internal damage. Carriers will accept claims for concealed damage if notified within fifteen days of delivery and the shipping container is retained for inspection.

**The Blodgett Oven Company cannot assume responsibility for loss or damage suffered in transit. The carrier assumed full responsibility for delivery in good order when the shipment was accepted. We are, however, prepared to assist you if filing a claim is necessary.**

### OVEN LOCATION

The well planned and proper placement of your oven will result in long term operator convenience and satisfactory performance.

The following clearances must be maintained between the oven and any combustible or non-combustible construction.

#### CTB

- Oven body left side – 0” (0cm)
- Oven body back – 0” (0cm)

#### CTBR

- Oven body right side – 0” (0cm)
- Oven body back – 0” (0cm)

It is essential that an adequate air supply to the oven be maintained to provide a sufficient flow of combustion and ventilation air.

- Area must be accessible for proper servicing.
- Keep the oven area free and clear of all combustibles such as paper, cardboard, and flammable liquids and solvents.
- To ensure proper operation, ventilation must not be obstructed in any way. Tripping of the blower motor thermal overload protective device is caused by excessive ambient temperature on the control side of the oven resulting from insufficient ventilation. This condition must be corrected immediately to avoid permanent damage to the oven.

Before making any utility connections to this oven, check the rating plate to be sure the oven specifications are compatible with the electrical services supplied for the oven.

1. The rating plate is attached to the underside of the oven upper ledge above the control panel.



## Stand Assembly

### STAND OPTIONS

#### Small Stands Without Shelves

- The 5-3/4" (15cm) stand is used for a single oven, when short legs are required for counter-top use.
- The 7" (18cm) stand is used for a double stacked oven, when the oven is to be located on the floor.

#### Stands With Shelves

- Three stands, 16" (40cm), 19" (48cm), and 24" (61cm) are available for different installation requirements.
- The 33" (84cm) stand is used for a single oven when counter space is limited.

#### Open Stands With Racks

- The 24" (61cm) or 33" (84cm) open stands are available with a rack support system located below the oven.

### STAND ASSEMBLY

#### Small Stands Without Shelves

1. Place stand frame upside down on a work surface.
2. Attach one leg to each of the corner stud bolts on the bottom of the stand top.
3. Place a lock washer and nut on each stud, and tighten securely.
4. The stand is now ready for the oven assembly.

#### Stands With Shelves

1. Place stand frame upside down on a work surface.
2. Attach one leg to each of the corner stud bolts on the bottom of the stand top.
3. Place a lock washer and nut on each bolt, and tighten. DO NOT tighten leg bolts completely.
4. Place the shelf between the legs so that the smooth top surface is facing the top of the stand.
5. Align the shelf holes with the bolt holes found near the bottom of each leg.
6. Insert a carriage bolt from the outside of the leg, through the leg, and through the shelf corner bracket.
7. Place a lock washer and nut on each bolt, and tighten securely.
8. Tighten the leg frame bolts.

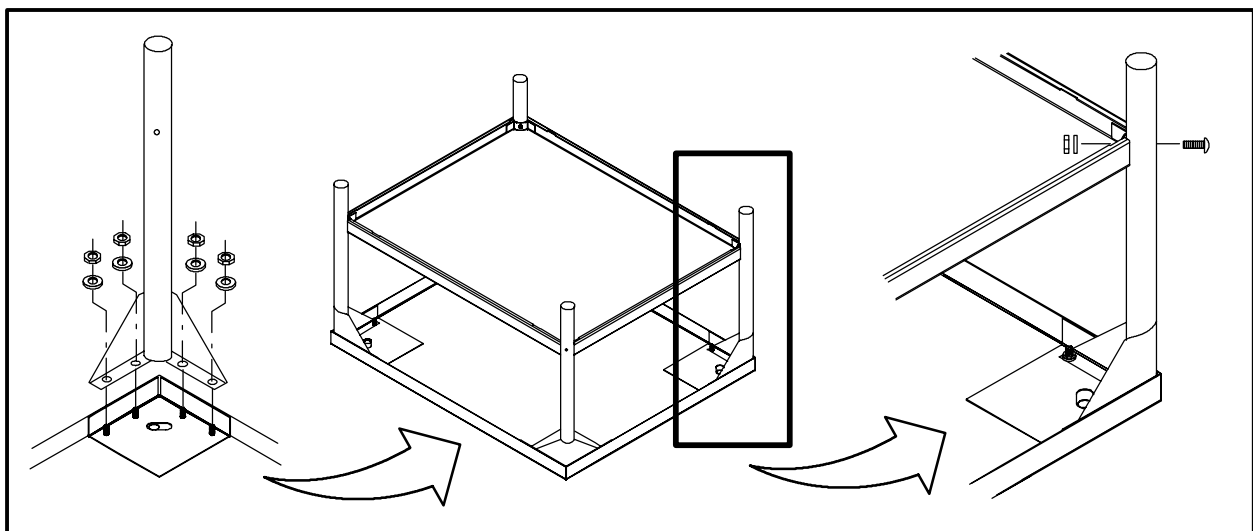

Figure 2



# Installation

## Stand Assembly

### Open Stands With Racks

1. Lay stand frame top down on the floor as shown. See Figure 3.
2. Position the four leg assemblies and support angles as shown. Attach with the 5/16-18 nuts provided. DO NOT tighten leg bolts completely.  
*NOTE: Be sure the support angles and clips are located correctly for your oven configuration. See Figure 3.*
3. Position the bottom shelf between the legs so that the smooth top surface is facing the top of the stand.
4. Align the shelf holes with the bolt holes found near the bottom of each leg.
5. Insert a carriage bolt from the outside of the leg, through the leg, and through the shelf corner bracket.

6. Place a lock washer and nut on each bolt, and tighten securely. See the Figure 2.
7. Repeat Steps 3–6 for the top shelf.  
*NOTE: Be sure the slots in the top shelf are aligned with the support angles.*
8. Insert the top of the rack stops into the two back clips on the angle supports as shown. Insert the bottom of the rack stops into the slots in the top shelf as shown.
9. Insert the rack supports into the remaining four clips on the angle supports as shown. Insert the bottom of the rack supports into the slots in the top shelf as shown.
10. Tighten all loose bolts.

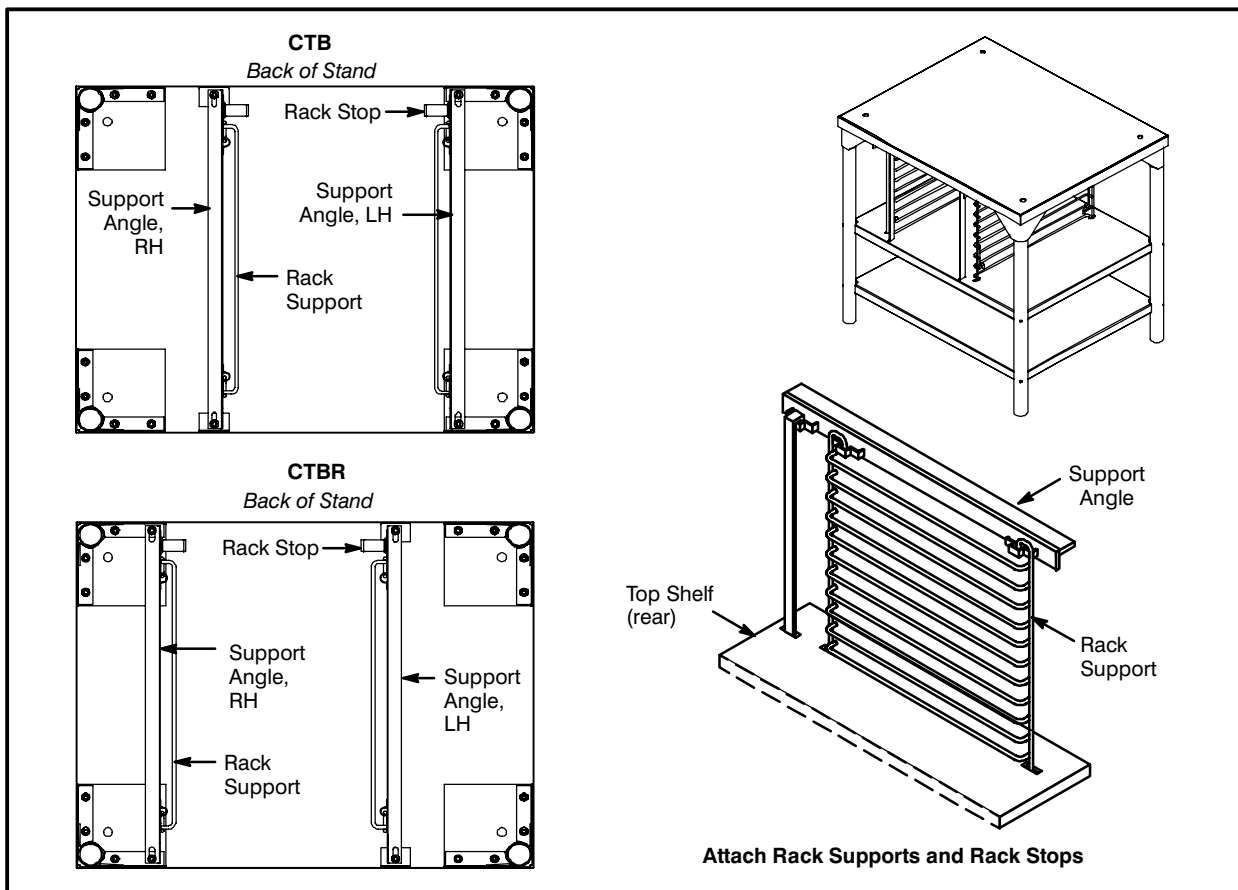

Figure 3



## Oven Assembly

### OVEN ASSEMBLY TO STAND

#### Single Section

1. Place the assembled stand in the location where the oven is going to be used.
2. Remove the side control compartment cover and open the front control panel of a single oven (or lower section).
3. With a tool, punch out the knock-outs in the oven bottom near each corner.
4. Set the oven on the stand. Center it to the frame.
5. Align the front, and rear bolt holes of the oven with the bolt holes in the stand.
6. Insert a bolt and washer, from the top down through each of the 2 holes.
7. Place a nut and washer on each of the 2 bolts, and tighten securely.
8. Replace the oven's side control compartment, and close the front control panel.

*NOTE: For single section ovens only. For double stacked ovens step 8 will be completed once the ovens are stacked.*

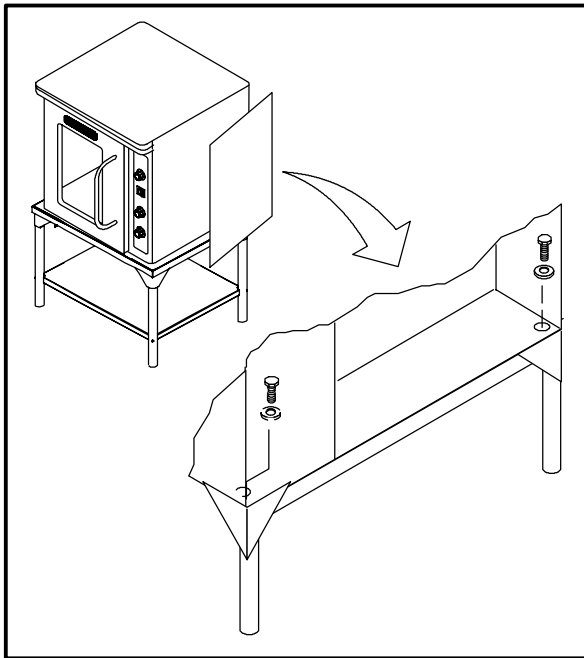

Figure 4

#### Double Section

1. Assemble the lower section to the stand as described. DO NOT replace the side control compartment or close the front control panel.
2. With a tool, punch out the knock-outs in the oven top of the lower oven.
3. Remove the side control compartment cover and open the front control panel of the upper oven.
4. With a tool, punch out the knock-outs in the bottom of the upper oven near each corner.
5. Set the upper oven on the lower oven.
6. Align the front, and rear bolt holes of the upper oven with the bolt holes in the bottom oven.
7. Insert a bolt and washer, from the top down through each of the 2 holes.
8. Place a nut and washer on each of the 2 bolts, and tighten securely.
9. Replace the control compartment cover, and close the front control panel on both of the ovens.

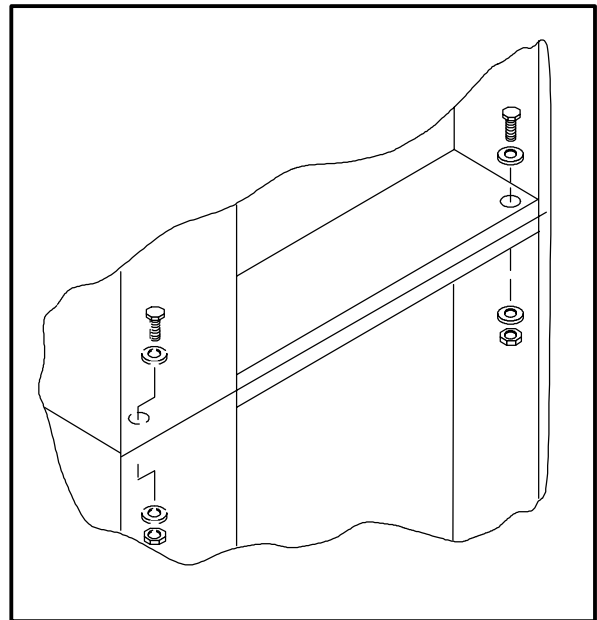

Figure 5



# Installation

## Oven Assembly

### 4" (10CM) LEG ATTACHMENT

1. Lay the oven on its side.
2. Screw one leg into each of the corner nuts.

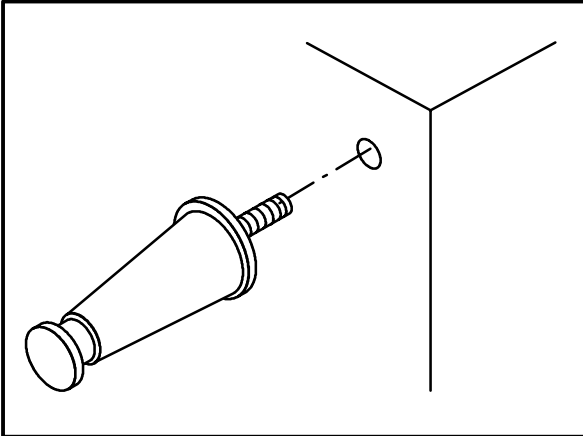

Figure 6

### CASTER INSTALLATION

*NOTE: Casters are not supplied for the 4" (10cm) legs, 5-3/4" (15cm) or 7" (18cm) stands.*

*NOTE: Install the locking casters on the front of the oven. Install the non-locking casters on the back of the oven.*

1. Insert the caster into the leg. Secure the caster to the leg by tightening the locknut.

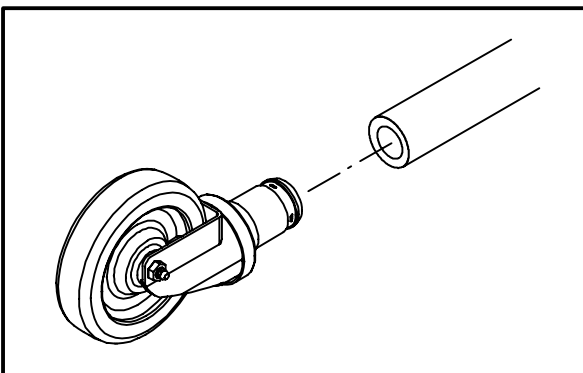

Figure 7

### OVEN LEVELING

After assembly, the oven should be leveled and moved to the operating location.

1. The oven can be leveled by adjusting the feet or casters located on the bottom of each leg.

### ADJUSTMENTS ASSOCIATED WITH INITIAL INSTALLATION

Each oven, and its component parts, have been thoroughly tested and inspected prior to shipment. However, it is often necessary to further test or adjust the oven as part of a normal and proper installation. These adjustments are the responsibility of the installer, or dealer. Since these adjustments are not considered defects in material or workmanship, they are not covered by the Original Equipment Warranty. They include, but are not limited to:

- calibration of the thermostat
- adjustment of the doors
- leveling
- tightening of fasteners.

No installation should be considered complete without proper inspection, and if necessary, adjustment by qualified installation or service personnel.



## Utility Connections – Standards and Codes

THE INSTALLATION INSTRUCTIONS CONTAINED HEREIN ARE FOR THE USE OF QUALIFIED INSTALLATION AND SERVICE PERSONNEL ONLY. INSTALLATION OR SERVICE BY OTHER THAN QUALIFIED PERSONNEL MAY RESULT IN DAMAGE TO THE OVEN AND/OR INJURY TO THE OPERATOR.

Qualified installation personnel are individuals, a firm, a corporation, or a company which either in person or through a representative are engaged in, and responsible for:

- the installation of electrical wiring from the electric meter, main control box or service outlet to the electric appliance.

Qualified installation personnel must be experienced in such work, familiar with all precautions required, and have complied with all requirements of state or local authorities having jurisdiction.

### U.S. and Canadian installations

All ovens, when installed, must be electrically grounded in accordance with local codes, or in the absence of local codes, with the *National Electrical Code, ANSI/NFPA 70–Latest Edition* and/or *Canadian National Electric Code C22.2* as applicable.

The ventilation of this oven should be in accordance with local codes. In the absence of local codes, refer to the National ventilation code titled, “*Standard for the Installation of Equipment for the Removal of Smoke and Grease Laden Vapors from Commercial Cooking Equipment*”, NFPA-96-Latest Edition.

### General export installations

Installation must conform with Local and National installation standards. Local installation codes and/or requirements may vary. If you have any questions regarding the proper installation and/or operation of your Blodgett oven, please contact your local distributor. If you do not have a local distributor, please call the Blodgett Oven Company at 0011-802-860-3700.





# Installation

## Electrical Connection

Wiring diagrams are located in the control compartment area.

Ovens are supplied for operation in several voltage choices, single or three phase grounded circuits.

The electric motor, indicator lights and related switches are interconnected through the one power source supplied to the oven.

1. The supply conduit enters through the rear of the oven and electrical block secured to the perforated panel at the back of the control compartment.

THE BLODGETT OVEN COMPANY CANNOT ASSUME RESPONSIBILITY FOR LOSS OR DAMAGE SUFFERED AS A RESULT OF IMPROPER INSTALLATION.

KW/Section	Volts	Phase	Amperes				Electrical Connection AWG*
			L1	L2	L3	N	
<b>60 HZ UNITS</b>							
5.6	208	1	27	–	27	–	8
5.6	208	3	24	12	15	–	10
5.6	220-240	1	24	–	24	–	8
5.6	220-240	3	21	11	14	–	10
8.0	208	1	35	–	35	–	6
8.0	208	3	22	20	21	–	10
8.0	220-240	1	32	–	32	–	6
8.0	220-240	3	20	18	19	–	10
<b>50 HZ UNITS</b>							
5.6	220–240	1	24	–	–	24	Size per local codes
8	220–240	1	35	–	–	35	
5.6	220/380	3	10	8	8	2	
8	220/380	3	14	12	12	2	
5.6	240/415	3	10	7	7	3	
8	240/415	3	13	11	11	2	
5.6	230/400	3	9	8	8	1	
8	230/400	3	13	11	11	2	



THE INFORMATION CONTAINED IN THIS SECTION IS PROVIDED FOR THE USE OF QUALIFIED OPERATING PERSONNEL. QUALIFIED OPERATING PERSONNEL ARE THOSE WHO HAVE CAREFULLY READ THE INFORMATION CONTAINED IN THIS MANUAL, ARE FAMILIAR WITH THE FUNCTIONS OF THE OVEN AND/OR HAVE HAD PREVIOUS EXPERIENCE WITH THE OPERATION OF THE EQUIPMENT DESCRIBED. ADHERENCE TO THE PROCEDURES RECOMMENDED HEREIN WILL ASSURE THE ACHIEVEMENT OF OPTIMUM PERFORMANCE AND LONG, TROUBLE-FREE SERVICE.

Please take the time to read the following safety and operating instructions. They are the key to the successful operation of your Blodgett conveyor oven.



### **SAFETY TIPS**

**For your safety read before operating**

#### **General safety tips:**

- If the oven needs to be moved for any reason, the supply cord must be disconnected from the unit before removing the restraint cable. Reconnect the restraint after the oven has been returned to its original location.
- DO NOT remove the control panel cover unless the oven is unplugged.



# Operation

## Solid State Manual

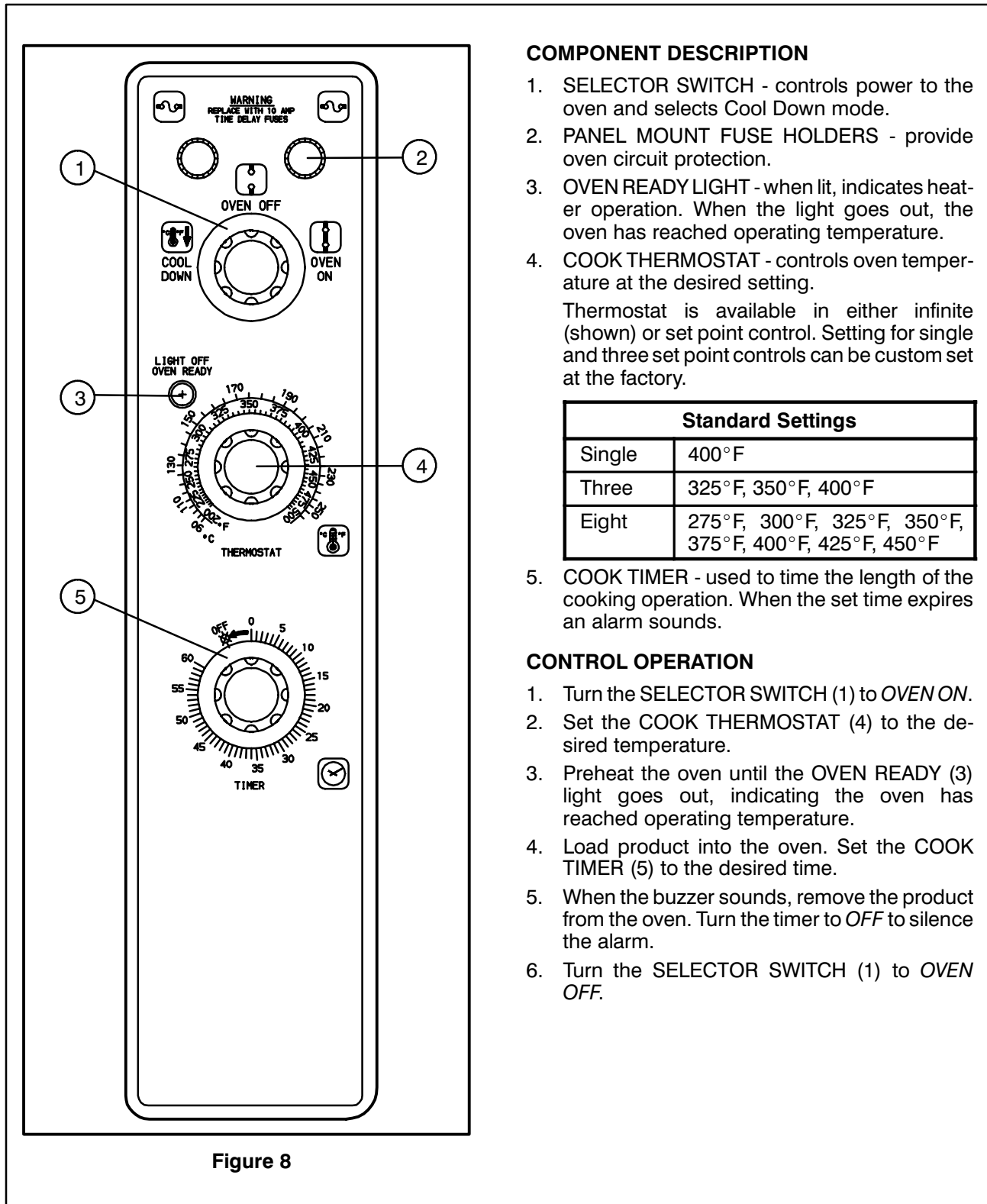

### COMPONENT DESCRIPTION

1. SELECTOR SWITCH - controls power to the oven and selects Cool Down mode.
2. PANEL MOUNT FUSE HOLDERS - provide oven circuit protection.
3. OVEN READY LIGHT - when lit, indicates heater operation. When the light goes out, the oven has reached operating temperature.
4. COOK THERMOSTAT - controls oven temperature at the desired setting.

Thermostat is available in either infinite (shown) or set point control. Setting for single and three set point controls can be custom set at the factory.

Standard Settings	
Single	400°F
Three	325°F, 350°F, 400°F
Eight	275°F, 300°F, 325°F, 350°F, 375°F, 400°F, 425°F, 450°F

5. COOK TIMER - used to time the length of the cooking operation. When the set time expires an alarm sounds.

### CONTROL OPERATION

1. Turn the SELECTOR SWITCH (1) to *OVEN ON*.
2. Set the COOK THERMOSTAT (4) to the desired temperature.
3. Preheat the oven until the OVEN READY (3) light goes out, indicating the oven has reached operating temperature.
4. Load product into the oven. Set the COOK TIMER (5) to the desired time.
5. When the buzzer sounds, remove the product from the oven. Turn the timer to *OFF* to silence the alarm.
6. Turn the SELECTOR SWITCH (1) to *OVEN OFF*.

## Solid State Digital

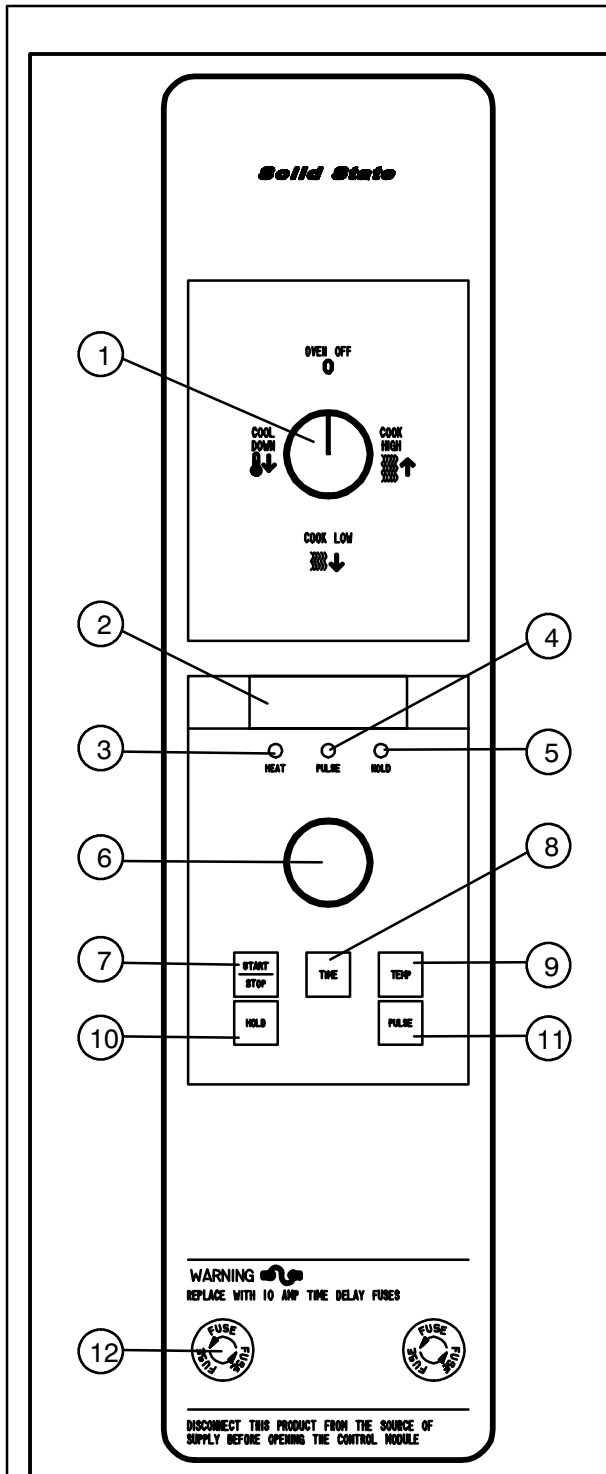

Figure 9

### COMPONENT DESCRIPTION

1. SELECTOR SWITCH - turns power to the oven on or off. Allows selection of Cook or Cool Down modes and fan speed (if applicable).
2. DISPLAY - displays time, temperature, or other information related to oven function.
3. HEAT LAMP - lights when heater is on.
4. PULSE LAMP - lights when Pulsed Fan Mode is turned on.
5. HOLD LAMP - lights when Hold Mode is turned on.
6. DIAL - used to enter set points in display.
7. START/STOP KEY - starts or stops the timer.
8. TIME KEY - used to show time in the display.
9. TEMP KEY - used to show set temperature in the display.  
*NOTE: Actual temperature is shown while the TEMP key is held down.*
10. HOLD KEY - turns Hold Mode on or off.
11. PULSE KEY - turns Pulse Mode on or off.
12. FUSES - provide oven circuit protection.

### PROGRAMMING

#### To set the cook temperature:

1. Press the TEMP (9) key.
2. Rotate the dial (6) to enter the cook temperature.

#### To set the cook time:

1. Press the TIME (8) key.
2. Rotate the dial (6) to enter the cook time.

*NOTE: Time is entered in hours : minutes or minutes : seconds.*

#### To set the hold time:

1. Press the HOLD key (10) to turn hold mode on.  
*NOTE: HOLD light is on.*
2. Rotate the dial (6) to enter the hold temperature.
3. Press the START/STOP key (7)

#### To set the pulse time:

1. Press the PULSE KEY (11) to turn pulse mode on.  
*NOTE: Pulse light is on.*
2. Rotate the DIAL (6) to enter the pulse time. Pulse time is a portion of the pre-set cook time.



# Operation

## Solid State Digital

### OPERATION

#### Cook

1. Turn the SELECTOR SWITCH (1) to the desired position.
2. Enter the cook time and temperature.
3. Load product into the oven.  
*NOTE: The display reads LOAD when the oven is near set temperature.*
4. Push the START/STOP key (7). The timer begins to count down.
5. When the cook timer reaches 00:00 the buzzer sounds and the display reads *DONE*.
6. Press the START/STOP key (7) to silence the buzzer.
7. Remove the product.

#### Cook with Hold

*NOTE: The HOLD light is on when hold mode is on and off when hold mode is off.*

1. Turn the SELECTOR SWITCH (1) to the desired position.
2. Enter the cook time and temperature.
3. Press the HOLD key (10). Enter the hold temperature.
4. Load product into the oven.  
*NOTE: The display reads LOAD when the oven is near set temperature.*
5. Push the START/STOP key (7). The timer begins to count down.
6. When the cook timer reaches 00:00 the buzzer sounds and the display reads *DONE*. The buzzer turns off after a few seconds. The display reads HOLD until the oven reaches the hold temperature. Then the timer begins to count up.
7. Push the START/STOP key (7) to stop the timer.
8. Remove the product.
9. Push the HOLD key (10) to turn off hold mode.

#### Cook with Pulse

*NOTE: The PULSE light is on when pulse mode is on and off when pulse mode is off.*

1. Turn the SELECTOR SWITCH (1) to the desired position.
2. Enter the cook time and temperature.
3. Press the PULSE KEY (11). Enter the pulse time.  
*NOTE: Pulse time is a portion of the cook time and does not increase the previously entered cook time.*
4. Load product into the oven.  
*NOTE: The display reads LOAD when the oven is near the set temperature.*
5. Push the START/STOP KEY (9). The timer begins to count down the cook time. The oven remains in pulse mode for the set pulse time. When the set time expires, the unit automatically switches to cook mode and continues counting down.
6. When the cook timer reaches 00:00 the buzzer sounds and the display reads *DONE*.
7. Push the START/STOP KEY (9) to turn the buzzer off.
8. Remove the product.

## Fan Delay and Pulse Plus Control

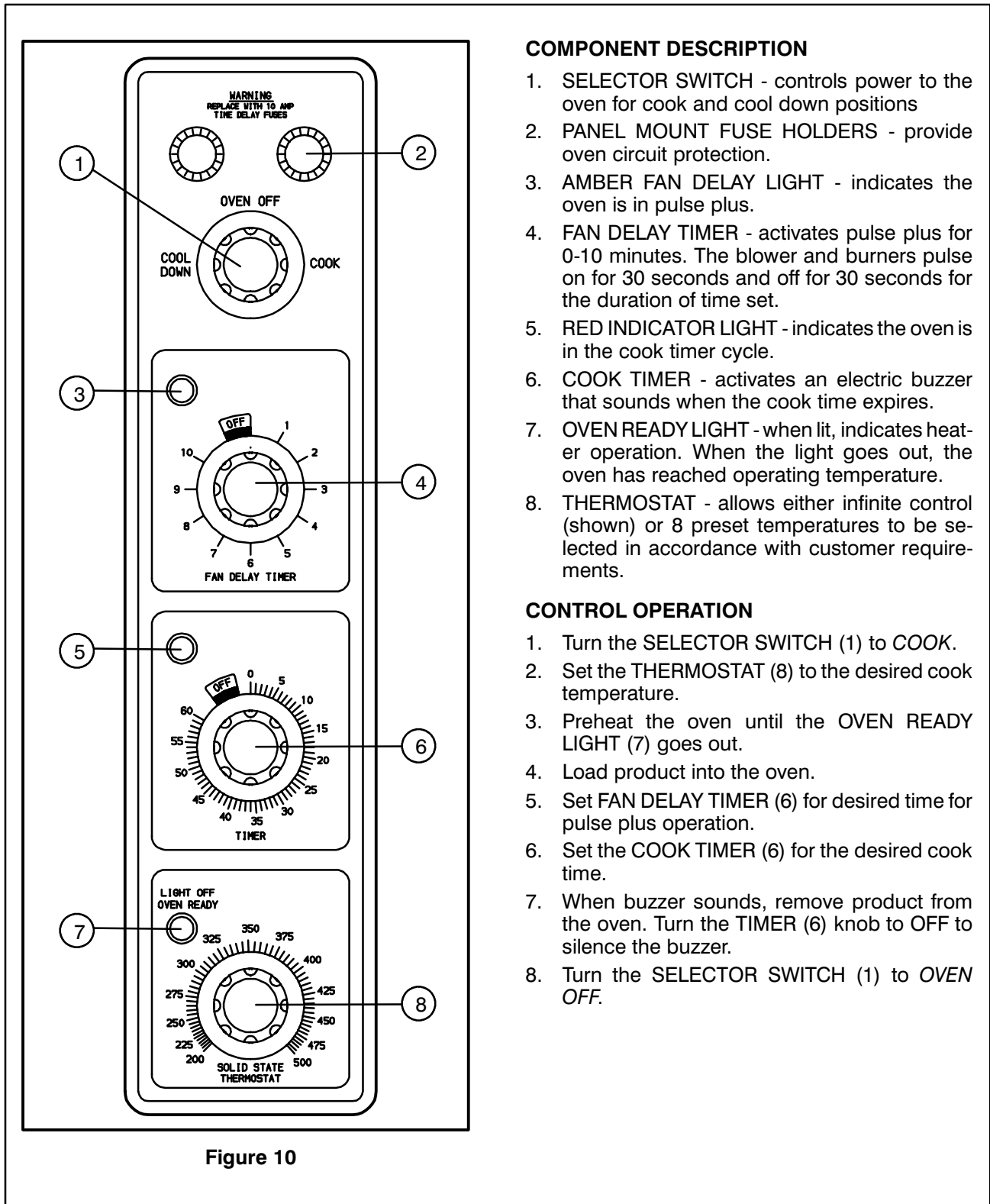

Figure 10

### COMPONENT DESCRIPTION

1. SELECTOR SWITCH - controls power to the oven for cook and cool down positions
2. PANEL MOUNT FUSE HOLDERS - provide oven circuit protection.
3. AMBER FAN DELAY LIGHT - indicates the oven is in pulse plus.
4. FAN DELAY TIMER - activates pulse plus for 0-10 minutes. The blower and burners pulse on for 30 seconds and off for 30 seconds for the duration of time set.
5. RED INDICATOR LIGHT - indicates the oven is in the cook timer cycle.
6. COOK TIMER - activates an electric buzzer that sounds when the cook time expires.
7. OVEN READY LIGHT - when lit, indicates heater operation. When the light goes out, the oven has reached operating temperature.
8. THERMOSTAT - allows either infinite control (shown) or 8 preset temperatures to be selected in accordance with customer requirements.

### CONTROL OPERATION

1. Turn the SELECTOR SWITCH (1) to COOK.
2. Set the THERMOSTAT (8) to the desired cook temperature.
3. Preheat the oven until the OVEN READY LIGHT (7) goes out.
4. Load product into the oven.
5. Set FAN DELAY TIMER (6) for desired time for pulse plus operation.
6. Set the COOK TIMER (6) for the desired cook time.
7. When buzzer sounds, remove product from the oven. Turn the TIMER (6) knob to OFF to silence the buzzer.
8. Turn the SELECTOR SWITCH (1) to OVEN OFF.



# Operation

## Cook and Hold

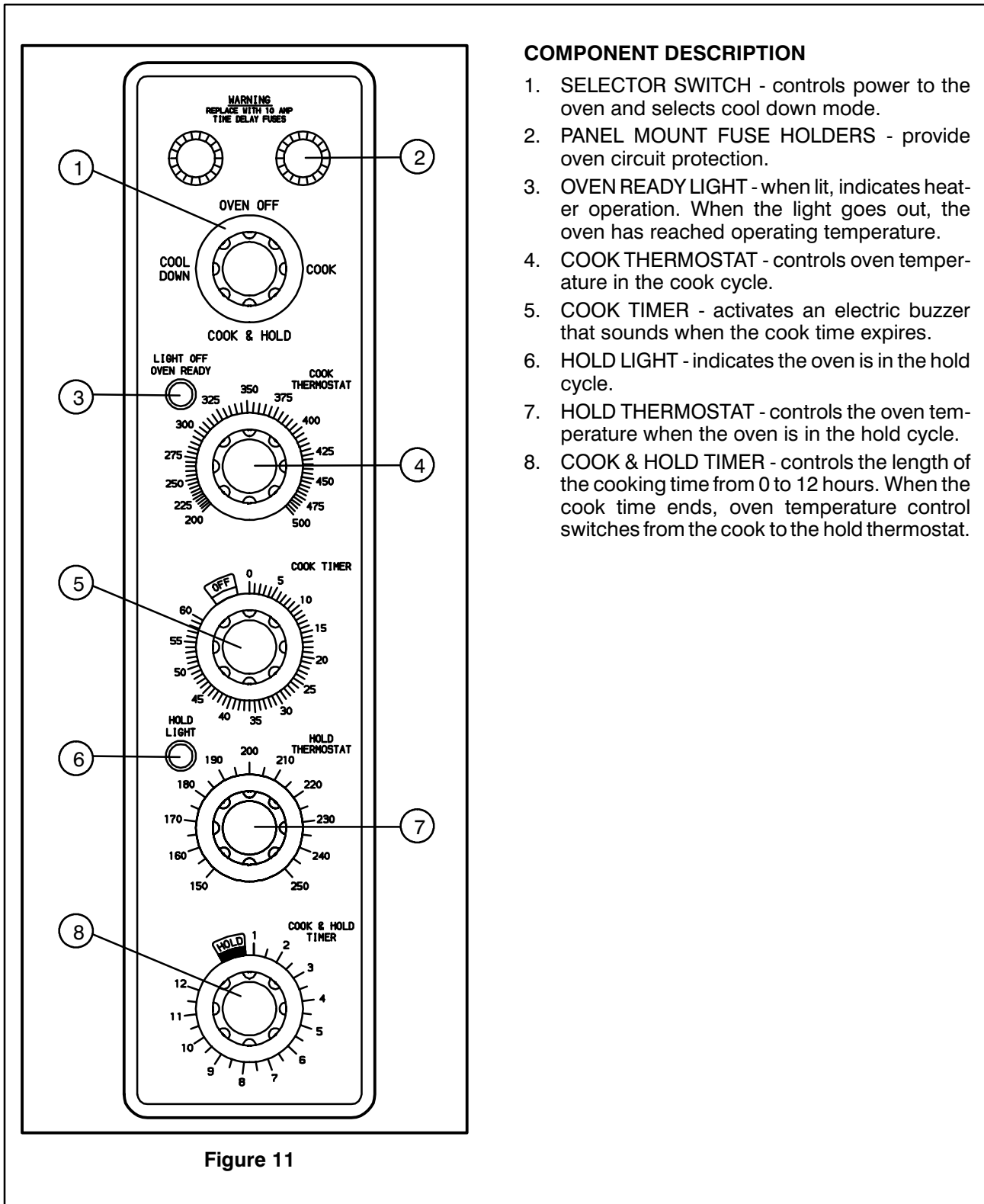

### COMPONENT DESCRIPTION

1. SELECTOR SWITCH - controls power to the oven and selects cool down mode.
2. PANEL MOUNT FUSE HOLDERS - provide oven circuit protection.
3. OVEN READY LIGHT - when lit, indicates heater operation. When the light goes out, the oven has reached operating temperature.
4. COOK THERMOSTAT - controls oven temperature in the cook cycle.
5. COOK TIMER - activates an electric buzzer that sounds when the cook time expires.
6. HOLD LIGHT - indicates the oven is in the hold cycle.
7. HOLD THERMOSTAT - controls the oven temperature when the oven is in the hold cycle.
8. COOK & HOLD TIMER - controls the length of the cooking time from 0 to 12 hours. When the cook time ends, oven temperature control switches from the cook to the hold thermostat.

## Cook and Hold

### CONTROL OPERATION

#### Cook Only

1. Turn the SELECTOR SWITCH (1) to *COOK*.
2. Set the COOK THERMOSTAT (4) to the desired temperature.
3. Preheat the oven until the OVEN READY LIGHT (3) goes out.
4. Load product into the oven. Set the COOK TIMER (5) to the desired cook time.
5. When the buzzer sounds, remove the product. Turn the COOK TIMER (5) to *OFF* to silence the buzzer.
6. Turn the SELECTOR SWITCH (1) to *OVEN OFF*.

#### Cook and Hold

1. Turn the SELECTOR SWITCH (1) to *COOK*.
2. Set the COOK THERMOSTAT (4) to the desired cook temperature.
3. Set the HOLD THERMOSTAT (7) to the desired hold temperature.
4. Preheat the oven until the LIGHT OFF OVEN READY (3) light goes out.
5. Load product into the oven.
6. Turn the SELECTOR SWITCH (1) to *COOK AND HOLD*.
7. Set the COOK AND HOLD TIMER (8) to the desired cook time.
8. When the cook time ends the oven switches to *HOLD* and the HOLD LIGHT (6) comes on.
9. The oven remains at the hold temperature until the product is removed and the oven is turned off.

*NOTE: In the hold cycle, the blower goes on and off with the elements.*

10. Turn the SELECTOR SWITCH (1) to *OVEN OFF*.

#### Cool Down:

1. For cool down operation set the SELECTOR SWITCH (1) to *COOL DOWN*.



# Operation

## CH-Pro3 (Solid State Programmable Digital Control)

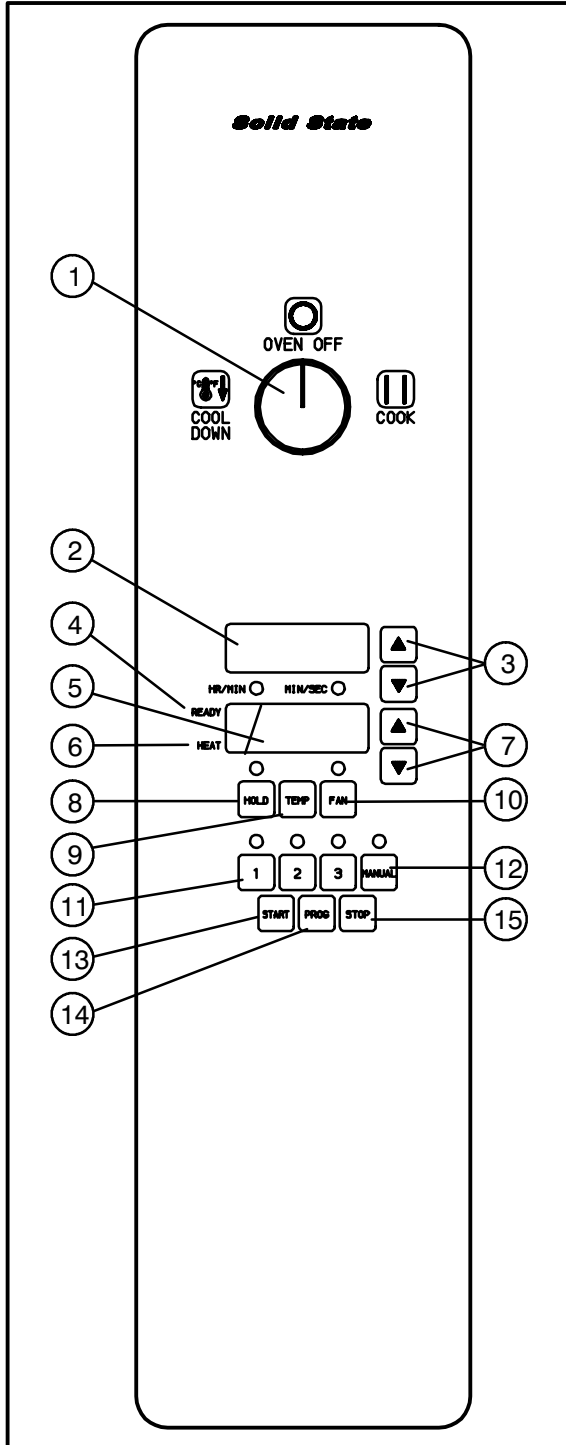

Figure 12

### COMPONENT DESCRIPTION

1. SELECTOR SWITCH – turns power to the oven on or off. Allows selection of cook or cool down modes and fan speed (if applicable).
2. TIME DISPLAY – gives cook time.
3. TIME ARROW KEYS – press to enter cook and/or pulse times.
4. READY INDICATOR – when lit indicates the oven has reached the setpoint temperature and product may be loaded.
5. TEMPERATURE DISPLAY – gives cook and hold temperatures.
6. HEAT INDICATOR – when lit indicates the oven is heating.
7. TEMPERATURE ARROW KEYS – press to enter cook and hold temperatures.
8. HOLD KEY – turns hold mode on or off.
9. TEMP KEY – press to display actual oven temperature.
10. FAN KEY – turns pulse mode on or off. The LED above the fan key is always on.
11. PRODUCT KEYS – three programmable keys.
12. MANUAL PRODUCT KEY – default product key used for manual operation.
13. START KEY – press to begin a cook cycle.
14. PROGRAM KEY – press to enter programming mode and save programmed settings.
15. STOP KEY – press to silence audible alarms and cancel cook cycles.

## CH-Pro3 (Solid State Programmable Digital Control)

### MANUAL OPERATION

*NOTE: Press the arrow keys to change the cook time and temperature at any point during manual operation.*

#### Cook Only:

1. Turn the SELECTOR SWITCH (1) to the desired position.
2. Press the MANUAL PRODUCT KEY (12). The manual and fan key LEDs light.
3. Press the TIME ARROW KEYS (3) to enter the cook time.
4. Press the TEMPERATURE ARROW KEYS (7) to enter the cook temperature.
5. The READY INDICATOR (4) lights when the oven is at the set temperature. Load product into the oven.
6. Press the START KEY (13). The TIME DISPLAY (2) counts down. The manual key LED flashes.
7. When the cook time expires the LEDs and both displays flash and an audible alarm sounds. Press the STOP KEY (15) to silence the alarm.
8. Remove the product.

#### Cook with Hold:

1. Turn the SELECTOR SWITCH (1) to the desired position.
2. Press the MANUAL PRODUCT KEY (12). The manual and fan key LEDs light.
3. Press the TIME ARROW KEYS (3) to enter the cook time.
4. Press the TEMPERATURE ARROW KEYS (7) to enter the cook temperature.
5. Press and hold the HOLD KEY (8). At the same time use the TEMPERATURE ARROW KEYS (7) to enter the hold temperature. The hold key LED lights.
6. The READY INDICATOR (4) lights when the oven is at the set temperature. Load product into the oven.

7. Press the START KEY (13). The TIME DISPLAY (2) counts down. The manual key LED flashes.
8. When the cook time expires both displays flash and an audible alarm sounds for several seconds then self cancels. The hold key LED flashes. The time display begins to count up while the oven cools to the hold temperature. When the oven reaches the hold temperature the time display resets to 00:00 then begins to count up the hold time. The fan cycles with heat demand in the hold mode.
9. Press the STOP KEY (15) to stop the timer.
10. Remove the product.
11. Push the HOLD KEY (8) to turn off hold mode.

#### Cook with Pulse:

1. Turn the SELECTOR SWITCH (1) to the desired position.
2. Press the MANUAL PRODUCT KEY (12). The manual and fan key LEDs light.
3. Press the TEMPERATURE ARROW KEYS (7) to enter the cook temperature.
4. Press the FAN KEY (10). The fan key LED flashes. Use the TIME ARROW KEYS (3) to enter the pulse time.
5. The READY INDICATOR (4) lights when the oven is at the set temperature. Load product into the oven.
6. Press the START KEY (13). The manual key LED flashes. The TIME DISPLAY (2) counts down. The fan cycles on for 30 seconds then off for 30 seconds until the set pulse time has expired.
7. When the pulse time expires both displays flash and an audible alarm sounds. Press the STOP KEY (15) to silence the alarm.
8. Remove the product.

#### Oven Shut Down:

1. Turn the SELECTOR SWITCH (1) to *OVEN OFF*.



# Operation

## CH-Pro3 (Solid State Programmable Digital Control)

### PROGRAMMING THE MANUAL KEY DEFAULT

1. Turn the SELECTOR SWITCH (1) to the desired position.
2. Press the MANUAL KEY (12). The manual and fan key LEDs light.
3. Press the PROGRAM KEY (14).
4. Press the TIME ARROW KEYS (3) to enter the cook time.
5. Press the TEMPERATURE ARROW KEYS (7) to enter the cook temperature.
6. **For Cook and Hold** – Press and hold the HOLD KEY (8). At the same time use the TEMPERATURE ARROW KEYS (7) to enter the hold temperature. The hold key LED lights.  
**For Cook with Pulse** – Press the FAN KEY (10). Use the TIME ARROW KEYS (3) to enter the pulse time. The fan key LED flashes.
7. Press the PROGRAM KEY (14) to save the program settings.

### MANUAL KEY DEFAULT OPERATION

1. Turn the SELECTOR SWITCH (1) to the desired position.
2. Press the MANUAL KEY (12). The applicable LEDs light.
3. Press the START KEY (13). The TIME DISPLAY (2) counts down. The manual key LED flashes.  
*NOTE: In Cook with Pulse the fan LED flashes.*  
*NOTE: Press the arrow keys to change the cook time and temperature at any point during manual key operation.*
4. When the cook time expires the applicable LEDs and both displays flash and an audible alarm sounds.
5. Press the STOP KEY (15) to silence the alarm.  
*NOTE: In Cook & Hold the alarm self cancels. The oven cools to the hold temperature and the time display counts up.*
6. Remove the product.
7. Turn the SELECTOR SWITCH (1) to OFF to shut down the oven.

### PROGRAMMING THE PRODUCT KEYS

1. Turn the SELECTOR SWITCH (1) to the desired position.
2. Press the desired PRODUCT KEY (11). The product and fan key LEDs light.
3. Press and hold the PROGRAM KEY (14) until the corresponding LED flashes, approximately five seconds.
4. Press the TIME ARROW KEYS (3) to enter the cook time.
5. Press the TEMPERATURE ARROW KEYS (7) to enter the cook temperature.
6. **For Cook and Hold** – Press and hold the HOLD KEY (8). At the same time use the TEMPERATURE ARROW KEYS (7) to enter the hold temperature. The hold key LED lights.  
**For Cook with Pulse** – Press the FAN KEY (10). Use the TIME ARROW KEYS (3) to enter the pulse time. The fan key LED flashes.
7. Press the PROGRAM KEY (14) to save the program settings.

### PRODUCT KEY OPERATION

1. Turn the SELECTOR SWITCH (1) to the desired position.
2. Press the desired PRODUCT KEY (11). The applicable LEDs light.
3. Press the START KEY (13). The TIME DISPLAY (2) counts down. The product key LED flashes.  
*NOTE: In Cook with Pulse the fan LED flashes.*
4. When the cook or pulse time expires the applicable LEDs and both displays flash and an audible alarm sounds.
5. Press the STOP KEY (15) to silence the alarm.  
*NOTE: In Cook and Hold the alarm self cancels. The oven cools to the hold temperature and the time display counts up.*
6. Remove the product.
7. Turn the SELECTOR SWITCH (1) to OFF to shut down the oven.

## Blodgett IQ2™ Control

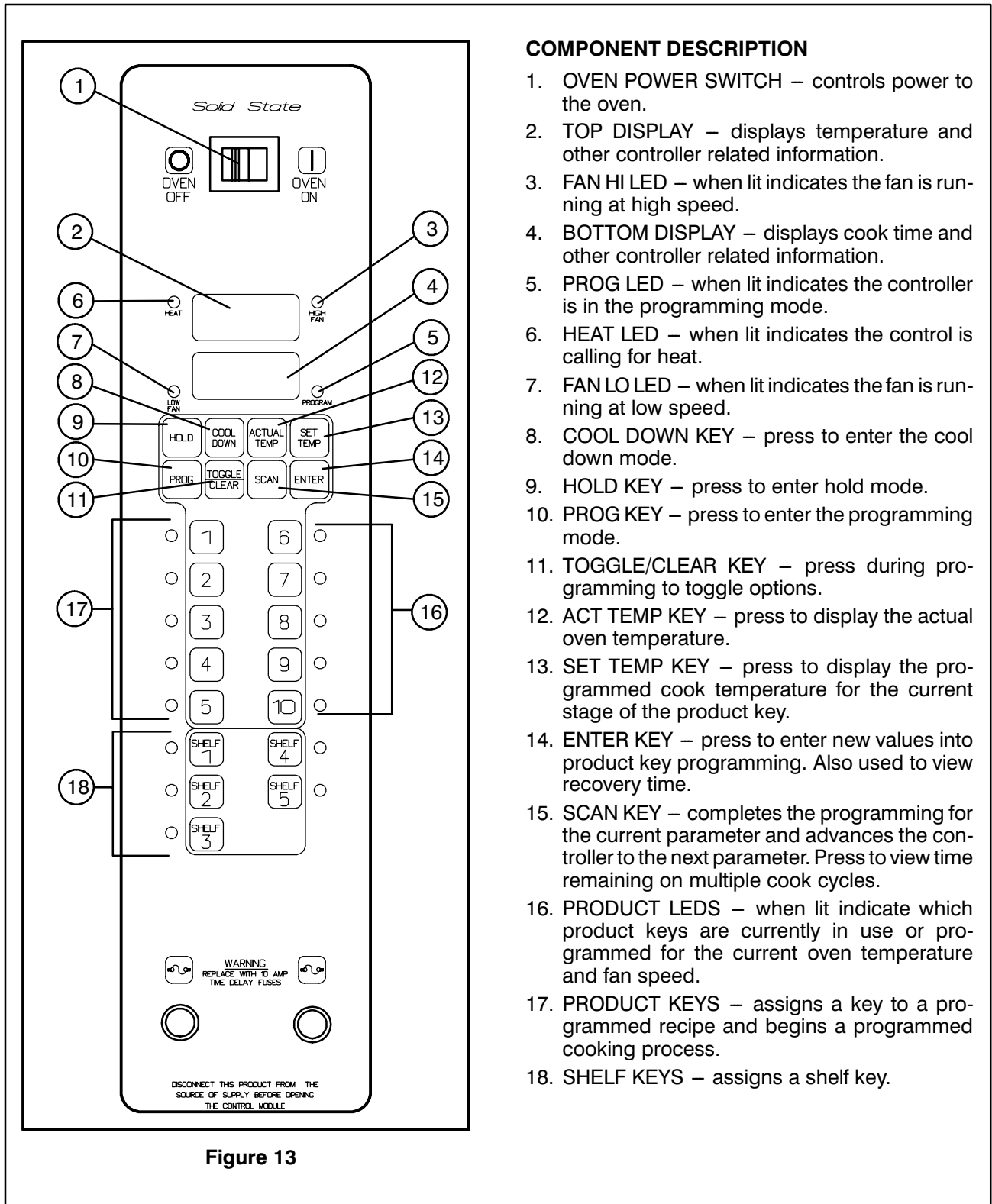

Figure 13

### COMPONENT DESCRIPTION

1. OVEN POWER SWITCH – controls power to the oven.
2. TOP DISPLAY – displays temperature and other controller related information.
3. FAN HI LED – when lit indicates the fan is running at high speed.
4. BOTTOM DISPLAY – displays cook time and other controller related information.
5. PROG LED – when lit indicates the controller is in the programming mode.
6. HEAT LED – when lit indicates the control is calling for heat.
7. FAN LO LED – when lit indicates the fan is running at low speed.
8. COOL DOWN KEY – press to enter the cool down mode.
9. HOLD KEY – press to enter hold mode.
10. PROG KEY – press to enter the programming mode.
11. TOGGLE/CLEAR KEY – press during programming to toggle options.
12. ACT TEMP KEY – press to display the actual oven temperature.
13. SET TEMP KEY – press to display the programmed cook temperature for the current stage of the product key.
14. ENTER KEY – press to enter new values into product key programming. Also used to view recovery time.
15. SCAN KEY – completes the programming for the current parameter and advances the controller to the next parameter. Press to view time remaining on multiple cook cycles.
16. PRODUCT LEDS – when lit indicate which product keys are currently in use or programmed for the current oven temperature and fan speed.
17. PRODUCT KEYS – assigns a key to a programmed recipe and begins a programmed cooking process.
18. SHELF KEYS – assigns a shelf key.



# Operation

## Blodgett IQ2™ Control

### OVEN OPERATION

#### Oven Startup:

1. Toggle the POWER SWITCH (1) to ON. The oven preheats to the lowest programmed first stage temperature. The LEDS (16) for all products with the same first stage temperature light. While the unit preheats the TOP DISPLAY (2) gives the set temperature. The BOTTOM DISPLAY (4) reads *Lo* if the oven is more than 10° below setpoint. When the oven reaches ±10° of the preheat temperature an alarm sounds and the bottom display reads *Ready*.

#### Single Product Cooking Procedure:

*NOTE: If the led next to the desired product key is lit skip step 1.*

1. Press the desired PRODUCT KEY (17). The oven preheats to the first stage temperature for the selected product. When the oven reaches ±10° of the preheat temperature an alarm sounds and the bottom display reads *Ready*.
2. Load the product into the oven. Press the desired PRODUCT KEY (17).

If the shelf timing function is toggled on for that product key, the top display reads *SHLF* and the bottom display reads the programmed product's time. Press a SHELF KEY (18) to assign the product to that shelf and start the cook cycle. The top display reads *SHLF*, the bottom display gives the shelf #. Within five seconds, the top display reads *SH-1*, the bottom display gives the remaining cook time.

If the shelf timing function is toggled off for that product key, pressing the product key will start the cook cycle. The TOP DISPLAY (2) reads ----. The BOTTOM DISPLAY (4) counts down the cook time in minutes: seconds.

*NOTE: If the selected product has a cook time of greater than 59:59 the top display reads Hr-- for the total number of hours. The bottom display counts down the cook time in minutes:seconds.*

*NOTE: If the selected product is a single stage recipe the LEDS for all single stage products with the same cook tempera-*

*ture and fan speed will light. If the selected product is a multiple stage recipe no other product LEDS will light.*

*NOTE: Press and hold the selected product key for three seconds to cancel the cook cycle for normal operation. To cancel the cook cycle when using shelf timing, press and hold the SHELF KEY (18) for 3 seconds or press TOGGLE/CLEAR (11) and the corresponding shelf key.*

3. When the cook time expires an alarm sounds and the top display reads *done*.
4. Press the selected product key to silence the alarm. Remove the product. If shelf timing is used, press the flashing SHELF KEY (18) to silence the alarm.

#### Multiple Batch Cooking Procedure:

This procedure is for single stage recipes with the same cook temperature and fan speed only.

*NOTE: If the led next to the first desired product key is lit skip step 1.*

1. Press the first desired PRODUCT KEY (17). The LEDS for all recipes with the same cook temperature and fan speed will light.

The oven preheats to the cook temperature for the selected product. When the oven reaches ±10° of the preheat temperature an alarm sounds and the bottom display reads *Ready*.

2. Load the product into the oven. Press the desired PRODUCT KEY (17).

If the shelf timing function is toggled on for that product key, the top display reads *SHLF* and the bottom display reads the programmed product's time. Press a SHELF KEY (18) to assign the product to that shelf and start the cook cycle. The top display reads *SHLF*, the bottom display gives the shelf #. Within five seconds, the top display reads *SH-1*, the bottom display gives the remaining cook time.

If the shelf timing function is toggled off for that product key, pressing the product key will start the cook cycle. The TOP DISPLAY (2) reads ----. The BOTTOM DISPLAY (2) counts down the cook time in minutes: seconds.



3. Load the second product. Press the appropriate PRODUCT KEY (17). Press a SHELF KEY (18) to activate shelf timing.

*NOTE: Only products with lighted LEDS may be selected.*

4. The top display reads *SHLF*. The bottom display gives the numbers of the shelves that have been assigned. Within five seconds the shelf with the least amount of time remaining is displayed. The led for the product with the least time remaining flashes faster than the led for the other products.

*NOTE: To view the remaining cook time for the other products press and hold the SCAN KEY (15). The bottom display cycles through the remaining cook times for each product. Only the led for the product with the cook time displayed will be lit.*

5. When a cook time expires an alarm sounds. The top display reads *donE*. The led for the finished product lights. All other LEDS are dark.
6. Press the SHELF KEY (18) for the finished product to silence the alarm. Remove the product. Close the oven door. The TOP DISPLAY (2) reads *SH-X* for the shelf with the least amount of cook time. The BOTTOM DISPLAY (4) counts down the cook time for the other product.
7. When the cook time expires an alarm sounds and the top display reads *donE*.
8. Press the SHELF KEY (18) to silence the alarm. Remove the product.

### **Oven Cool Down:**

1. Close the oven door. Press the COOL DOWN KEY (8).

*NOTE: Cool down cannot be activated with the oven door open. Once the cool down cycle has begun the doors may be opened to speed the cooling process.*



# Operation

## Blodgett IQ2™ Control

### PROGRAMMING SINGLE STAGE RECIPES

#### Entering the Programming Mode:

1. Press and hold the PROG KEY (10). The top display reads *CodE*.
2. Use the product keys to enter the programming access code: 3 1 2 4. Press the ENTER KEY (14). The top display reads *Prod*.
3. Press the desired product key followed by the ENTER KEY (14).

*NOTE: During the programming process you may: Press the TOGGLE/CLEAR KEY (11) to erase the current setting or toggle between specific settings. Press the SCAN KEY (15) to move to the next programming function keeping the current setting the same. Press the PROG KEY (10) to exit the programming mode.*

#### Programming the Cook Time:

1. The top display reads P1:\_\_. The bottom display gives the current programmed cook time for stage 1 in minutes:seconds. Press the TOGGLE/CLEAR KEY (11). Use the product keys to enter the new cook time. Press the ENTER KEY (14) to save the new cook time.
2. The top display reads P2:\_\_. The control is asking for the cook time for stage 2 of this recipe. Press the TOGGLE/CLEAR KEY (11) to enter a time of 0:00:00 for P2:.

*NOTE: This tells the controller that there are no more stages for this recipe. Once a single stage recipe has been established the control will only allow entries for one stage on all further parameters for this product.*

3. Press the ENTER KEY (14) again. The top display reads P1:. The bottom display shows the cook time.
4. Press the SCAN KEY (15) to advance the programming mode to cook temperature.

#### Programming the Cook Temperature:

1. The top display reads *Ct-1*. The bottom display gives the current cook temperature. Use the product keys to enter the desired cook temperature.
2. Press the SCAN KEY (15) to advance the programming mode to fan speed.

#### Programming the Fan Speed:

1. The top display reads *SPd1*. The bottom display gives the current fan speed. Press the TOGGLE/CLEAR KEY (11). The bottom display toggles between *HI* and *Lo*.
2. Press the SCAN KEY (15) to advance the programming mode to the fan cycle time.

#### Programming the Fan Cycle Time:

There are 3 options for fan cycle time: Pulse, Heat and Full. Pulse allows the fan to turn on and off as programmed. Heat allows the fan to operate with heat only. Full provides continuous fan operation.

1. The top display reads *CYC1*. The bottom display gives the current fan cycle. Press the TOGGLE/CLEAR KEY (11). The bottom display toggles between *PULS*, *HEAt* and *FULL*.
2. If heat or full are selected press the SCAN KEY (15) to save the new fan cycle and advance to timing mode.

If pulse is selected press the SCAN KEY (15) and continue with Steps 3–4 to program the pulse cycle.

3. The top display reads *on-1*. The bottom display gives the current pulse on time. Use the product keys to enter the desired pulse on time from 10 to 60 seconds. Press the SCAN KEY (15).
4. The top display reads *of-1*. The bottom display gives the current pulse off time. Use the product keys to enter the desired pulse off time from 10 to 60 seconds. Press the SCAN KEY (15) to advance the programming mode to shelf mode.



### Programming the Shelf ID:

The Shelf ID option can be turned on or off for specific product keys.

*NOTE: Shelf ID is not allowed with multiple stage recipes.*

1. The top display reads *SHLF*. The bottom display reads the current shelf ID mode. Press the TOGGLE/CLEAR KEY (11) to toggle between yes and no. Press the SCAN KEY (15) to advance the programming mode to timing.

### Programming the Timing Mode:

There are 3 options for timing mode: Straight, Flex and Sensitivity.

1. The top display reads *tC-1*. The bottom display gives the current timing mode. Press the TOGGLE/CLEAR KEY (11) to toggle between *St*, *FL* and *SEns*.

*NOTE: Sensitivity adjusts the cook time to compensate for any difference between the setpoint and actual temperature. The lower the sensitivity value the shorter the time adjustment. Sensitivity values are set in the manager level programming.*

If Shelf ID is activated, all three timing modes are available. If Shelf ID is not activated, only straight or flex timing modes are available.

2. Press the SCAN KEY (15) to advance the programming mode to hold mode.

### Programming Hold Mode:

The hold mode can be toggled on or off for specific product keys.

1. The top display reads *HOLD*. The bottom display reads the current hold mode. Press TOGGLE/CLEAR KEY (11) to toggle between on and off. Press the SCAN KEY (15).
2. If the hold mode is activated, the bottom display give the current hold time. Press the TOGGLE/CLEAR KEY (11). Use the product keys to enter the new hold time. Press the SCAN KEY (15).
3. The bottom display gives the current hold temperature. Press the TOGGLE/CLEAR KEY (11). Use the product keys to enter the new hold temperature from 140-210°F (60-99°C). Press the SCAN KEY (15).
4. The top display reads *HFAN* (hold fan speed). The bottom display gives the current hold fan speed setting. Press the TOGGLE/CLEAR KEY (11) to toggle between high and low. Press the SCAN KEY (15) to exit the hold mode programming.

### Check all Settings (SEE Mode):

The SEE mode allows the operator to scroll through and view settings of a particular product key.

1. Press the PROG KEY (10). The top display reads *Code*.
2. Use the product keys to enter the SEE access code: 2 4 4 4. Press the ENTER KEY (14). The top display reads *SEE*.
3. Press the product key you wish to view. Press the ENTER KEY (14).
4. The control will automatically scroll through the programmable features showing the programmed values for each.

### Exiting the programming mode:

1. The top display reads *Prod*. Press the PROG KEY (10). The control returns to operating mode.



# Operation

## Blodgett IQ2™ Control

### PROGRAMMING MULTIPLE STAGE RECIPES

#### Entering the Programming Mode:

1. Press and hold the PROG KEY (10). The top display reads *CodE*.
2. Use the product keys to enter the programming access code: 3 1 2 4. Press the ENTER KEY (14). The top display reads *Prod*.
3. Press the desired product key followed by the ENTER KEY (14).

#### Programming the Cook Time:

*NOTE: When multiple stage cooking is being used, the countdown time displayed during cooking is the sum of all stages.*

1. The top display reads P1:\_\_. The bottom display gives the current programmed cook time for stage 1 in minutes:seconds. Press the TOGGLE/CLEAR KEY (11). Use the product keys to enter the new cook time. Press the ENTER KEY (14) to save the new cook time.
2. The top display reads P2:\_\_. The control is asking for the cook time for the second stage of this recipe. Repeat Step 1 for each additional stage.
3. When the cook times for all stages are programmed, press the TOGGLE/CLEAR KEY (11) to clear the bottom display.

*NOTE: This tells the controller that there are no more stages for this recipe. Once the number of stages has been established the control will only allow entries for these stages on all further parameters for this product.*

4. Press the ENTER KEY (14) again. The display reads P1:. The bottom display shows the cook time.
5. Press the SCAN KEY (15) to advance the programming mode to cook temperature.

#### Programming the Cook Temperature:

1. The top display reads *Ct-1*. The bottom display gives the current cook temperature for stage 1 of this recipe. Use the product keys to enter the desired cook temperature.
2. Press the ENTER KEY (14) to save the new cook temperature for stage 1. The top display reads *Ct-2*.

*NOTE: Repeat Steps 1-2 to program the cook temperature for additional stages. When the cook temperature for the final stage has been entered the top display reads *Ct-1*.*

3. Press the SCAN KEY (15) to advance the programming mode to fan speed

#### Programming the Fan Speed:

1. The top display reads *SPd1*. The bottom display gives the current fan speed. Press the TOGGLE/CLEAR KEY (11). The bottom display toggles between *Hi* and *Lo*.
2. Press the SCAN KEY (15) to advance the programming mode to the fan cycle time.



### Programming the Fan Cycle Time:

There are 3 options for fan cycle time: Pulse, Heat and Full. Pulse allows the fan to turn on and off as programmed. Heat allows the fan to operate with heat only. Full provides continuous fan operation.

1. The top display reads *CYC1*. The bottom display gives the current fan cycle for stage 1. Press the TOGGLE/CLEAR KEY (11). The bottom display toggles between *PULS*, *HEAt* and *FULL*.

2. Press the ENTER KEY (14) to save the new fan cycle for stage 1. The top display reads *CYC2*.

*NOTE: Repeat Steps 1–2 to program the fan cycle for additional stages.*

3. When the fan cycle for the final stage has been entered press the SCAN KEY (15).

If no pulse cycles are programmed the control advances to timing mode.

If pulse is used, the control returns to the first stage programmed for the pulse fan option. Follow Steps 4–5 to program the pulse on and off time.

4. The top display reads *on–x*. The bottom display gives the current pulse on time for this stage. Use the product keys to enter the desired pulse on time from 10 to 60 seconds. Press the SCAN KEY (15).

5. The top display reads *of–x*. The bottom display gives the current pulse off time. Use the product keys to enter the desired pulse off time from 10 to 60 seconds. Press the SCAN KEY (15). The control advances to the next stage programmed for the pulse fan option.

*NOTE: Repeat Steps 4–5 to program cycle times for all pulse fan stages. When the final pulse off time has been entered the control advances to timing mode.*

### Programming the Timing Mode:

*NOTE: It may be necessary to press the ENTER KEY (14) until the top display reads *tC–1*.*

There are 2 options for timing mode: Straight and Flex.

1. The top display reads *tC–1*. The bottom display gives the current timing mode. Press the TOGGLE/CLEAR KEY (11) to toggle between *St*, and *FL*.

2. Press the ENTER KEY (14) to save the new timing mode for stage 1. The top display reads *tC–2*.

*NOTE: Repeat Steps 1–2 to program the timing mode for additional stages.*

3. When the timing mode for the final stage has been entered press the SCAN KEY (15).

### Programming Hold Mode:

The hold mode can be toggled on or off for specific product keys.

1. The top display reads *HOLD*. The bottom display reads the current hold mode. Press TOGGLE/CLEAR KEY (11) to toggle between on and off. Press the SCAN KEY (15).

2. The bottom display give the current hold time. Press the TOGGLE/CLEAR KEY (11). Use the product keys to enter the new hold time. Press the SCAN KEY (15).

3. The bottom display gives the current hold temperature. Press the TOGGLE/CLEAR KEY (11). Use the product keys to enter the new hold temperature from 140-210°F (60-99°C). Press the SCAN KEY (15).

4. The top display reads *HFAN* (hold fan speed). The bottom display gives the current hold fan speed setting. Press the TOGGLE/CLEAR KEY (11) to toggle between high and low. Press the SCAN KEY (15) to exit the hold mode programming.

### Exiting the programming mode:

1. The top display reads *Prod*. Press the PROG KEY (10). The control returns to operating mode.



# Operation

## Blodgett IQ2™ Control

### MANAGER LEVEL PROGRAMMING

#### Entering the programming mode

1. Press the PROG KEY (10). The top display reads *Code*.
2. Use the product keys to enter the programming access code: 4 5 1 2. Press the ENTER KEY (14). The top display reads *SYS*.

#### Programming hold

Hold allows product to be kept warm in the oven at a programmed time and temperature by pressing the HOLD KEY (9).

1. Press the SCAN KEY (15). The top display reads *Hold*. Press the TOGGLE/CLEAR KEY (11) to toggle between *YES* and *no*. Press the SCAN KEY (15).

##### If no is chosen:

- a.) Press the SCAN KEY (15) to advance to programming the setback mode.

##### If yes is chosen:

- a.) The top display reads *HOLD*. The bottom display gives the current hold time. Press the TOGGLE/CLEAR KEY (11). Use the product keys to enter a hold time from 0 to 9 hours. Press the SCAN KEY (15) to enter the new hold time (HR:MN)..
- b.) The top display reads *HOLD*. The bottom display gives the current hold temperature. Press the TOGGLE/CLEAR KEY (11). Use the product keys to enter a hold temperature from 140°F–210°F. Press the SCAN KEY (15) to enter the new hold temperature.
- c.) The top display reads *H FAn*. The bottom display gives the current fan mode. To change the fan mode press the TOGGLE/CLEAR KEY (11). The bottom display toggles between *Hi* and *Lo*. Press the SCAN KEY (15) to enter the new fan mode and continue with programming the setback mode.

#### Programming the setback mode

The setback mode operates as a power saving feature. After a period of non-use (the setback time) the oven temperature automatically decreases to the setback temperature. The oven will maintain this temperature until a product key is pressed. The minimum setback time is 20:00.

1. The top display reads *SEtb*. The bottom display gives the setback mode. To change the setback press the TOGGLE/CLEAR KEY (11). The bottom display toggles between *YES* and *no*. Press the SCAN KEY (15).

##### If no is chosen:

- a.) The controller advances to programming the temperature mode.

##### If yes is chosen:

- a.) The bottom display gives the current setback time. Press the TOGGLE/CLEAR KEY (11). Use the product keys to enter the desired setback time. Press the SCAN KEY (15) to enter the new setback time.
- b.) The bottom display gives the current setback temperature. Press the TOGGLE/CLEAR KEY (11). Use the product keys to enter a setback temperature from 140°F–300°F. Press the SCAN KEY (15) to enter the new setback and continue with programming the temperature mode.

#### Programming the temperature mode (°F or °C)

1. The top display reads *dEg*. The bottom display gives the units. To change the units press the TOGGLE/CLEAR KEY (11). The bottom display toggles between *F* and *C*.
2. Press the SCAN KEY (15) to enter the new temperature units and continue programming the shelf sensitivity.



### Programming the shelf sensitivity

The controller allows the user to program a sensitivity value (0–9) for each shelf position. The sensitivity value will shorten or stretch cook time depending upon shelf position.

*NOTE: SEN1 is the top shelf position, SEN5 is the bottom shelf position.*

1. The display reads SEN1.
2. Press the TOGGLE/CLEAR KEY (11) to clear the current value to the desired value. Use the product key numbers to input a new sensitivity value.
3. Press the SCAN KEY (15) to advance to the next shelf position, SEN2.
4. Repeat steps 2–3 for all five shelf positions.

### Exiting the programming mode

1. The top display reads SYS. Press the PROG KEY (10). The control returns to the operating mode.

### ERROR CODES AND ALARMS

*NOTE: The error codes will appear in the top display. All error codes are accompanied by an audible alarm.*

*Hi* Oven temperature is more than 40°F above the highest setpoint.

*Prob* Probe failure.

*HEAT ERR* From a cool start (below 140°F), the oven takes more than 10 minutes to climb from 150-300°F. Press the TOGGLE/CLEAR KEY (11) to clear the prompt. This code indicates a problem with the system. Contact a service technician.

*FAN ERR* Indicates a fan failure during a call for heat. Press the TOGGLE/CLEAR KEY (11) to clear the alarm. The FAN ERR display remains active. Press the TOGGLE/CLEAR KEY (11) again to clear the message and return the system to normal operation. If condition persists turn off the oven and contact a service technician.

*FANC ERR* Indicates a contact failure has occurred in the fan control circuit. Press the TOGGLE/CLEAR KEY (11) to clear the alarm. The FANC ERR display remains active. Press the TOGGLE/CLEAR KEY (11) again to clear the message and return the system to normal operation. If condition persists turn off the oven and contact a service technician.

*DOOR OPEN* The controller senses the door is open. Close the door. If the door is closed contact a service technician.



# Operation

## How Cook and Hold Works

With the optional COOK & HOLD feature, meat is roasted at lower temperatures for longer periods of time. This preserves flavor and tenderness and prevents over drying. There are three phases in cook and hold roasting.

- **Primary Cooking** – controlled by the COOK & HOLD TIMER. The meat is cooked at a low temperature until approximately 2/3 done.
- **Cooking from Stored Heat** – when the primary cook time expires, the oven automatically switches to HOLD. The product continues to cook from the heat stored in the oven. Meat must remain in the hold cycle for a minimum of 1-1/2 to 2 hours before being served.
- **Hold** – holds the product for several hours before serving without loss of moisture or tenderness.

All meat should be completely thawed by refrigeration. Using frozen meat increases the cook time causing shrinkage.

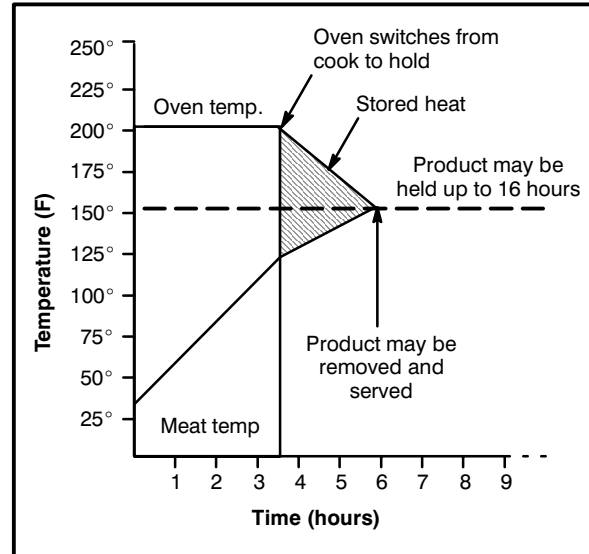

Figure 14

Product	Cook Temp.	Hold Temp.	Quantity	Cook Time (Hrs)	Min. Hold Time (Hrs)	Total Time (Hrs)
Prime rib, bone cap off 14-18 lbs. (6.4-8.1 kg)	200°F 93°C	140°F 60°C	1	3	1	4
			3	3-1/4	1-1/2	4-3/4
			6	3-1/2	2	5-1/2
Prime rib, bone cap on 14-18 lbs. (6.4-8.1 kg)	200°F 93°C	140°F 60°C	1	3-1/2	1	4-1/2
			3	4	1-1/2	5-1/2
			6	4-1/2	2	6-1/2
Top or bottom rounds 20-22 lbs. (9.1-10.0 kg)	200°F 93°C	140°F 60°C	1	3-1/2	1	4-1/2
			3	4	1-1/2	5-1/2
			6	4-1/2	2	6-1/2
Pork roast or ham 10-12 lbs. (4.5-5.4 kg)	250°F 121°C	170°F 76°C	2	4	1	5
			4	4-1/4	1-1/2	5-3/4
			6	4-1/2	2	6-1/2
Turkey 20-22 lbs. (9.1-10.0 kg)	250°F 121°C	170°F 76°C	1	3-1/4	1	4-3/4
			6	4	1-1/2	5-1/2
Leg of Lamb, bone in 8-10 lbs. (4.36-4.5 kg)	225°F 107°C	160°F 71°C	2	2-1/2	1	3-1/2
			4	2-3/4	1-1/2	4-1/4
			6	3	2	5

## General Guidelines for Operating Personnel

### COOK TIMES AND TEMPERATURES

#### Preheating the oven

Always preheat the oven before baking or roasting. We recommend preheating 50°F (10°C) above the cook temperature to offset the drop in temperature when the doors are opened and cold product is loaded into the oven. Set the thermostat to the cook temperature after the product is loaded.

*NOTE: For frozen product, preheat the oven 100°F (38°C) above the cook temperature.*

#### Cook Temperatures

Generally, cook temperatures should be 50°F (10°C) lower than deck or range oven recipes. If the edges of the product are done but the center is raw, or if there is color variation, reduce the thermostat setting another 15–25°F (10–15°C). Continue to reduce the cook temperature on successive loads until the desired results are achieved.

*NOTE: Cooking at excessive temperatures will not reduce cook time, it will produce unsatisfactory baking and roasting results.*

#### Cook Time

Check the product in about half the time recommended for deck or range oven recipes. Record times and temperatures which provide best results for future reference.

*NOTE: Cook time will vary with the amount of product loaded, the type of pan and the temperature.*

### OPERATING TIPS

#### Pans and Racks

Product or pan height determines how many racks are used. The oven holds up to 9 racks.

Load the oven from the bottom, centering the pans on the rack. Never place a pan or aluminum foil on the bottom of the oven. This obstructs the flow of air and results in uneven baking and roasting.

#### Roasting

To reduce shrinkage when roasting, place meat directly on the racks. Place a sheet pan one-half full of water in the bottom rack position. The water evaporates, increasing humidity in the oven chamber. The pan catches grease from the meat, making oven cleaning easier.

#### Baking

Weigh the product to ensure equal distribution in each pan. Varying amounts of product will cause uneven baking results.

#### Fans

The fan must be operating for the oven to heat. Use the Pulse Plus feature to allow light or liquid product to set in the pan and to avoid rippling towards the fan. If your oven is not equipped with this feature use the following procedure.

1. Preheat the oven 25°F (15°C) above the baking temperature.
2. Load the oven with product. Close the doors.
3. Set the thermostat to the baking temperature.
4. Turn the oven off.
5. Allow the product to set for 5–7 minutes with the fan off. The residual heat in the oven sets the product.
6. Turn the oven on for the remainder of the bake.

#### Lights

Turn the oven lights off when not viewing the product. Leaving the lights on for extended periods of time shortens the bulb life considerably.



# Operation

## Suggested Times and Temperatures

Product	Temperature	Time	# Shelves
<b>Meats</b>			
Hamburger Patties (5 per lb)	400°F (205°C)	8-10 mins.	10
Steamship Round (80 lb. quartered)	275°F (135°C)	2 hrs 45 mins.	2
Standing Rib Choice (20 lbs, trimmed, rare)	235°F (115°C)	2 hrs 45 mins.	2
Banquet Shell Steaks (10 oz. meat)	450°F (235°C)	7-8 mins.	5
Swiss Steak after Braising	275°F (135°C)	1 hr.	5
Baked Stuffed Pork Chop	375°F (190°C)	25-30 mins.	5
Boned Veal Roast (15 lbs.)	300°F (150°C)	3 hrs. 10 mins.	2
Lamb Chops (small loin)	400°F (205°C)	7-8 mins.	5
Bacon (on racks in 18" x 26" pans)	400°F (205°C)	5-7 mins.	10
<b>Poultry</b>			
Chicken Breast & Thigh	350°F (175°C)	40 mins.	5
Chicken Back & Wing	350°F (175°C)	35 mins.	5
Chicken (2 <sup>1</sup> / <sub>2</sub> lbs. quartered)	350°F (175°C)	30 mins.	5
Turkey Rolled (18 lb. rolls)	310°F (155°C)	3 hrs 45 mins.	3
<b>Fish and Seafood</b>			
Halibut Steaks, Cod Fish (frozen 5 oz)	350°F (175°C)	20 mins.	5
Baked Stuffed Lobster (2 <sup>1</sup> / <sub>2</sub> lb.)	400°F (205°C)	10 mins.	3
Lobster Tails (frozen)	425°F (220°C)	9 mins.	5
<b>Cheese</b>			
Macaroni & Cheese Casserole	350°F (175°C)	30 mins.	5
Melted Cheese Sandwiches	400°F (205°C)	8 mins.	10
<b>Potatoes</b>			
Idaho Potatoes (120 ct.)	400°F (205°C)	50 mins.	5
Oven Roasted Potatoes (sliced or diced)	325°F (165°C)	10 mins.	5
<b>Baked Goods</b>			
Frozen Berry Pies (22 oz)	325°F (150°C)	35 mins.	5 (30 pies)
Fresh Apple Pie (20 oz.)	350°F (175°C)	25-30 mins.	5 (30 pies)
Pumpkin Pies (32 oz.)	300°F (150°C)	30-50 mins.	5 (20 pies)
Fruit Crisp	300°F (150°C)	25 mins.	5
Bread (24 - 1 lb. loaves)	325°F (155°C)	30 mins.	3
Southern Corn Bread	375°F (190°C)	15-20 mins.	5
Baking Soda Biscuits	400°F (205°C)	6 mins.	5
Brown & Serve Rolls	350°F (175°C)	15 mins.	5
Sheet Cakes (5 lb. mixed batter per pan)	325°F (160°C)	16-18 mins.	5
Chocolate Cake	325°F (160°C)	20 mins.	5
Brownies	325°F (150°C)	15 mins.	5

*NOTE: Actual times and temperatures may vary considerably from those shown above. They are affected by weight of load, temperature of the product, recipe, type of pan and calibration of thermostat. Should your recipe vary, write in your proven time and temperature for ready reference.*



## Cleaning and Preventative Maintenance

### CLEANING THE OVEN

Painted and stainless steel ovens may be kept clean and in good condition with a light oil.

1. Saturate a cloth, and wipe the oven when it is cold.
2. Dry the oven with a clean cloth.

On the stainless front or interiors, deposits of baked on splatter may be removed with any non-toxic industrial stainless steel cleaner. Heat tint and heavy discoloration may be removed with any non-toxic commercial oven cleaner.

1. Apply cleaners when the oven is cold. Always rub with the grain of the metal.

The porcelain interior can be cleaned with any commercial oven cleaner. Be sure caustic cleaning compounds DO NOT come in contact with the temperature probe, aluminized steel heating element cover, and blower wheel.

1. Remove the racks, rack supports and blower wheel from the oven.
2. Soak the parts in a solution of ammonia and water.
3. Reinstall after cleaning.

### PREVENTATIVE MAINTENANCE

The best preventative maintenance measures are, the proper installation of the equipment and a program for routinely cleaning the ovens.

#### Annual Maintenance

This oven requires no lubrication, however, the venting system should be checked annually for possible deterioration resulting from moisture and corrosive flue products.

If maintenance or repairs are required, contact your local Blodgett service company, a factory representative or the Blodgett Oven company.



#### **WARNING!!**

**Always disconnect the appliance from the power supply before servicing or cleaning.**



# Maintenance

## Troubleshooting Guide

POSSIBLE CAUSE(S)	SUGGESTED REMEDY
SYMPTOM: Heating elements do not come on.	
<ul style="list-style-type: none"> <li>• Oven not plugged in.</li> <li>• Power switch on the control panel is off.</li> <li>• Control set below ambient temperature.</li> <li>• Doors are open.</li> <li>• Computerized controls – error code on display.</li> </ul>	<ul style="list-style-type: none"> <li>• Plug in electrical supply cord.</li> <li>• Set the control panel to COOK or OVEN ON.</li> <li>• Set to desired cook temperature.</li> <li>• Close doors.</li> <li>• *</li> </ul>
SYMPTOM: Oven does not come to ready.	
<ul style="list-style-type: none"> <li>• The oven has not reached preheat temperature.</li> <li>• Fan delay feature may be activated, if applicable.</li> <li>• Internal problem with main temperature control.</li> </ul>	<ul style="list-style-type: none"> <li>• Wait for oven to reach preheat temperature.</li> <li>• Deactivate fan delay feature.</li> <li>• *</li> </ul>
SYMPTOM: Convection fan does not run.	
<ul style="list-style-type: none"> <li>• Oven is not plugged in.</li> <li>• Oven is not set to the cook mode.</li> <li>• Circuit breaker tripped.</li> <li>• Fan delay feature may be activated, if applicable.</li> <li>• Doors are open</li> </ul>	<ul style="list-style-type: none"> <li>• Plug in electrical supply cord.</li> <li>• Set the control panel to COOK or OVEN ON.</li> <li>• Reset the breaker.</li> <li>• Deactivate fan delay feature.</li> <li>• Close doors.</li> </ul>
SYMPTOM: General baking problems.	
<ul style="list-style-type: none"> <li>• Computerized controls – incorrect product programming.</li> <li>• Thermostat out of calibration.</li> </ul>	<ul style="list-style-type: none"> <li>• Reprogram control per Operation section.</li> <li>• *</li> </ul>
<p>*Denotes remedy is a difficult operation and should be performed by qualified personnel only. It is recommended, however, that All repairs and/or adjustments be done by your local Blodgett service agency and not by the owner/operator. Blodgett cannot assume responsibility for damage as a result of servicing done by unqualified personnel.</p>	



### WARNING!!

**Always disconnect the power supply before cleaning or servicing the oven.**

**CUSTOMER  
INSERT  
WIRING DIAGRAM  
HERE**