

# Operations & Service Manual

RT5-HC & GHC-5



Model: GHC-5



Model: RT5-HC  
(Rotisserie not included)



## Giles Enterprises, Inc.

An ISO9001 Registered Company

2750 Gunter Park Drive West • Montgomery, AL 36109 USA

Phone: (334) 272-1457 Fax: • (334) 272-3561 • Internet: [www.gilesent.com](http://www.gilesent.com)

Service Hotline (Toll Free): 1-800-554-4537 (USA & Canada Only)

Form No. 65968 (Release date: 1/98)(Revision Date: 11/1/04)(Revision Level: B)





## LIMITED WARRANTY

- Subject to the terms and conditions of this Limited Warranty as herein stated, all Giles Enterprises, Inc., Foodservice Equipment and parts purchased new from an authorized Giles Enterprises, Inc., representative are warranted as to defects in material or workmanship for a period of 12 months from the date of installation, provided, however, that with regard to labor costs in connection with this warranty, see below. All installations must be made by a qualified installing agency in accordance with all applicable codes and/or regulations in the jurisdiction in which installed. Limited warranty coverage is extended to the original owner only and is void if the unit is resold.
- During the Limited Warranty period, Giles Enterprises, Inc. will replace or recondition, at its factory, any part or parts of this unit which Giles Enterprises, Inc. inspectors judge defective, provided the unit has been subjected to normal usage, properly installed, operated and serviced. This Limited Warranty does not cover cosmetic damage, and damage due to acts of God, accident, misuse, alteration, negligence, abuse of the Giles Foodservice Equipment or the use of unorthodox repair methods. All parts replaced under this Limited Warranty carry only the unexpired term of this Limited Warranty. Limited Warranty service may be furnished only by an authorized Giles Enterprises, Inc., representative.
- If Limited Warranty service is requested, Giles Enterprises, Inc., will send factory-authorized service representatives to repair, recondition, replace or inspect units of its manufacture with such labor being rendered without cost to owner for ninety (90) days from the date of installation. Otherwise, service, including labor and transportation charges or other expenses, in connection with the removal or installation of any part or parts supplied under this Limited Warranty, are specified on the original sales contract between the purchaser and the authorized Giles Enterprises, Inc., representative.
- Giles Enterprises, Inc. reserves the right to change or improve its equipment and parts in any way without obligation to alter such equipment or parts previously manufactured.
- Giles Enterprises, Inc. makes no further warranties, express or implied including implied warranties of merchantability or fitness for a particular purpose, and has no other obligation or liability not specifically stated herein.
- Repair or replacement as provided under this Limited Warranty is the exclusive remedy. Giles Enterprises, Inc., shall not be liable for any incidental or consequential damages for breach of any express or implied warranty on this product, except to the extent prohibited by applicable law. Any implied warranty of merchantability or fitness for a particular purpose on this product is limited in duration to the duration of this Limited Warranty.
- Used Giles Enterprises, Inc., Foodservice Equipment or parts or Giles Enterprises, Inc., Foodservice Equipment or parts not purchased from an authorized Giles Enterprises, Inc., representative, carry no warranties, express or implied.



<b>Safety</b> .....	<b>v</b>
Safety Overview .....	v
Specific Safety Precautions .....	vi
<b>1. Introduction</b> .....	<b>1</b>
1-01. Construction .....	1
1-02. Standard Features .....	1
1-03. Specifications .....	2
1-03.01. Overall Dimensions for RT5-HC or GHC-5 .....	2
1-03.02. Regulatory Listings .....	3
1-03.03. Unit Weights .....	3
<b>2. Installation</b> .....	<b>5</b>
2-01. Unpacking .....	5
2-02. Location and Clearances .....	6
2-02.01. Clearances for GHC-5 .....	6
2-02.02. Clearances for RT5-HC .....	7
2-03. Electrical Requirements .....	8
2-04. Electrical Connections .....	9
2-05. Cabinet Shelf Divider Installation .....	10
2-06. Cabinet Shelf Installation or Removal .....	11
2-07. RT-5 Rotisserie Installation .....	12
<b>3. Overview</b> .....	<b>13</b>
3-01. Cabinet Components .....	14
<b>4. Operation</b> .....	<b>17</b>
4-01. Operation Procedure .....	17
4-02. Normal Shut-Down .....	18
4-03. Emergency Shut-Down .....	18
<b>5. Cleaning</b> .....	<b>19</b>
5-01. Cleaning Procedure .....	19
<b>6. Troubleshooting</b> .....	<b>21</b>
6-01. Troubleshooting Procedures .....	21
<b>7. Parts List</b> .....	<b>23</b>
7-01. Parts Ordering and Service Information .....	23
7-02. Light Replacement .....	24
7-03. Ballast and Leg Replacement .....	24
7-04. Door and Shelf Replacement .....	26
7-05. Component Replacement .....	28
7-06. Light Housing Assembly .....	30



<b>8.</b>	<b>Wiring Diagram . . . . .</b>	<b>33</b>
8-01.	Wiring Diagram RT5-HC & GHC-5 120/60/1 . . . . .	34
8-02.	Wiring Diagram RT5-HC & GHC-5 230/50/1 . . . . .	36

## Safety

### Safety Overview

The instructions contained in this manual have been prepared to assist you in learning the proper procedures for installing and servicing your unit.

Throughout this manual, safety precautions are identified through the use of the safety alert symbol and three signal words: **DANGER, WARNING**, and **CAUTION**. All safety alert information precedes the step(s) to which they apply. Suggested, recommended, or other noteworthy information is identified through the use of **NOTES**. Additionally, certain words are used to indicate a specific meaning or to add emphasis.

The following words are used as indicated throughout the manual:

**Shall:** understood to be mandatory.

**Should:** understood to be advisory.

**May:** understood to be permissive.

**Will:** indicates a future event/condition to occur.

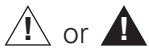

(Safety Alert Symbol)

Used in conjunction with signal words (**DANGER, WARNING**, or **CAUTION**) to alert you of potential personal injury hazards, immediately preceding precautionary measures that pertain to subsequent step(s). Obey all safety messages that follow this symbol to avoid possible injury or death. Failure to adhere to safety precautions identified by the safety alert symbol may also void the warranty.

#### **DANGER**

- Indicates an imminently hazardous situation which, if not avoided, will result in death or serious injury. Use of this is limited to the most extreme situations.

#### **WARNING**

- Indicates a potentially hazardous situation which, if not avoided, could result in death or serious injury.

#### **CAUTION**

- Indicates a potentially hazardous situation which, if not avoided, may result in minor or moderate injury. Also used to alert against unsafe practices.

#### **CAUTION**

- When used without the safety alert symbol, **CAUTION** indicates a potentially hazardous situation which, if not avoided, may result in equipment/property damage, and void the warranty.

#### **NOTE:**

- Identifies suggested, recommended, or other noteworthy information.

## Specific Safety Precautions

For your safety, please observe the following precautions when operating or servicing your Holding Cabinet. Read the following important safety information to avoid personal injury and/or damage to the equipment.

### **DANGER**

- Always disconnect the source of the main power before removing any service covers.
- Failure to comply with these **DANGER** notices will result in death or serious injury, equipment/property damage, and void the warranty.

### **WARNING**

- **DO NOT** use or store gasoline or other flammable liquids or vapors in the vicinity of this or any other appliance!
- Consult a qualified electrician to ensure all electrical specifications have been met and the unit is properly grounded.
- Before installing or servicing this equipment, read the contents of this manual thoroughly.
- Improper installation, adjustment, alteration, service or maintenance could result in death or serious injury, equipment/property damage, and void the warranty.
- Failure to comply with these **WARNING** notices could result in death or serious injury and equipment/property damage.

## CAUTION

- The Giles Rotisserie Holding Cabinet must remain in the upright (vertical) position.
- Exercise care when lifting or moving the unit. See Section 1-3.3. for unit weights.
- Exercise care when removing the wooden shipping crate from around the unit.
- The Holding Cabinet and its parts are HOT!
  - Temperatures inside the unit may exceed 150°F (65.6°C).
  - Exercise caution when operating, loading/unloading food, cleaning or servicing.
  - Wearing of thermal oven mitts is recommended.
- Allow the unit to thoroughly cool before cleaning or servicing.
- **DO NOT** install the unit next to combustible walls and materials.
- Food products must reach an internal temperature of 150°F to 170°F (65.6°C to 76.7°C) before placing in the Giles Rotisserie Holding Cabinet.
- Food products must be maintained at a temperature of 150°F (65.6°C) minimum while inside the Giles Rotisserie Holding Cabinet. Failure to comply could violate local health codes.
- During cleaning of the Giles Rotisserie Holding Cabinet:
  - **DO NOT** steam clean.
  - **DO NOT** use products containing chlorine.
  - **DO NOT** use abrasive products, steel wool or scouring pads.
- Lower liner shelf must be installed on lower shelf prior to operating unit. This will help to prevent product from over heating.
- Always use containers that can withstand temperature of 250°F (121°C).
- Proper temperature range is dependent upon the amount and type of product contained in the Giles Rotisserie Holding Cabinet.
- Using a Food Thermometer, periodically check that food products on each rack are being maintained at a minimum of 150°F (65.6°C).
- Comply with all appropriate state and/or local health regulations regarding the cleaning and sanitation of equipment.
- Please ensure this appliance is electrically grounded and installed in accordance with local codes, or in the absence of local codes, with the National Electrical Code ANSI/NFPA No. 70-1984.
- Failure to comply with these **CAUTION** notices may result in equipment/property damage and void the warranty.

**NOTE:**

- If the shipping crate is damaged, immediately inspect the unit and notify the carrier of any damage to the unit.
- To aid the electrician, an electrical wiring diagram is contained in this manual. Refer to the wiring diagram during installation or servicing.
- For difficult areas, a mild biodegradable nontoxic degreaser (such as Clear Magic or Simple Green) may be used.
- Preheat the Giles Holding Cabinet to 150°F (65.6°C) before transferring food into it.

## 1. Introduction

Congratulations on the purchase of your new Giles Holding Cabinet (RT5-HC or GHC-5) manufactured by Giles Enterprises, Inc., Montgomery, Alabama (USA), hereafter referred to as "Giles". Two different models (RT5-HC or GHC-5) are available from Giles. The RT5-HC includes a top flange to mount a RT-5 Rotisserie to the on top of the holding cabinet. The GHC-5 may only be used as a holding cabinet and can not be used for mounting a rotisserie. Proper care and maintenance of these units will ensure years of trouble-free service.

The Giles Holding Cabinet has been developed with flexibility in mind. It was designed to maximize menu selections, while keeping the food products fresh and maintaining them at the proper serving temperature, just waiting for your customers to enjoy.

To help protect your investment in this equipment, we recommend taking a few moments to familiarize yourself with the installation, cleaning and maintenance procedures contained in this manual. Read these instructions before installation and use. Adherence to these recommended procedures minimizes the potential for costly "down-time" and equipment repairs. Please retain this manual for future reference.

### 1-01. Construction

The Giles Holding Cabinet exterior is constructed of stainless steel. The unit is also constructed with clear tempered glass that allows for maximum viewing from either side of unit.

### 1-02. Standard Features

#### Temperature Controls

- Thermostat controlled heating with pilot indicator, adjustable up to 200°F (93.3°C).
- Thermometer to monitor internal temperature of cabinet.

#### Doors

- Tempered Glass Front and Rear Doors allow access for both the customer and the deli personnel.

#### Lights

- Two fluorescent lights for product viewing.

#### Shelving

- Three removable shelves to allow for ease of cleaning.

1-03. Specifications

The following section gives various specifications of the unit.

1-03.01. Overall Dimensions for RT5-HC or GHC-5

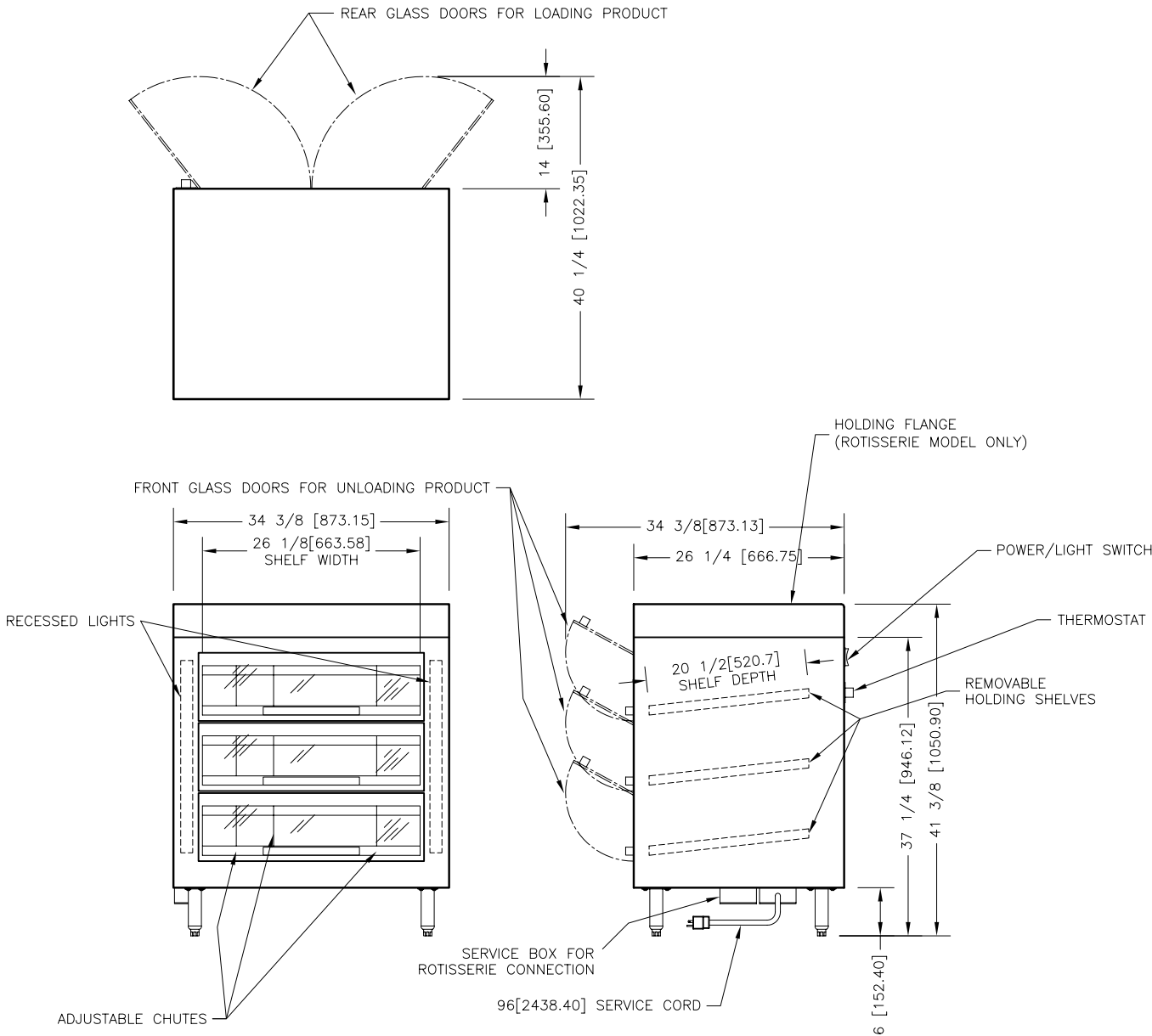



## 1-03.02. Regulatory Listings

UL (US and Canada)  
NSF

## 1-03.03. Unit Weights

Unit	Crated Weight	Uncrated Weight (without product)
RT5-HC or GHC-5	341 lbs [154.6 kg]	247 lbs [112 kg]



**Notes:**

## 2. Installation

This section provides a summary of procedures necessary to install your new Giles Holding Cabinet, Model RT5-HC or GHC-5. Before installing or servicing this equipment, thoroughly read the contents of this manual. Following these procedures will help ensure a safe and proper installation.

### 2-01. Unpacking

Your unit should arrive packaged in a wooden crate, covered with plastic shipping wrap, and secured to a wooden platform by means of high-tensile strength strapping. Perform the following steps to uncrate the unit:

**NOTE:**

- If the crate is damaged, immediately inspect the unit and notify the carrier of any damage to the unit.

 **CAUTION**

- Exercise care when lifting or moving the unit. Please see Section 1-03.03 for unit weights.
- Exercise care when removing the wooden crate from around the unit.
- Failure to comply with these **CAUTION** notices may result in minor or moderate injury, equipment/property damage, and void the warranty.

1. Position the packaged RT5-HC or GHC-5 in an area with sufficient room for unpacking.
2. Cut and remove the plastic shipping wrap and any high-tensile strength straps from the exterior of the wooden crate.
3. Carefully use a hammer and pry bar to remove the wooden crate from around the unit.
4. Cut and remove the plastic shipping wrap and high-tensile strength strapping that secures the unit to the wooden platform.
5. Before installing, check the unit for damage. If unit was damaged during shipment, notify the carrier immediately and file a claim.
6. Carefully remove the unit from the wooden platform and place at the installation site.

## 2-02. Location and Clearances

**⚠ WARNING**

- **DO NOT** install the unit next to combustible walls or materials. Failure to maintain safe distances may result in fire.
- **DO NOT MODIFY, ALTER OR ADD ATTACHMENTS TO THIS EQUIPMENT.**
- **DO NOT MOUNT ON COUNTER. UNIT IS FOR FLOOR MOUNTING ONLY.**

1. Select a location with adequate space to properly operate and service the unit.
2. Maintain the clearances shown in Section 2-02.01. and 2-02.02.

### 2-02.01 Clearances for GHC-5

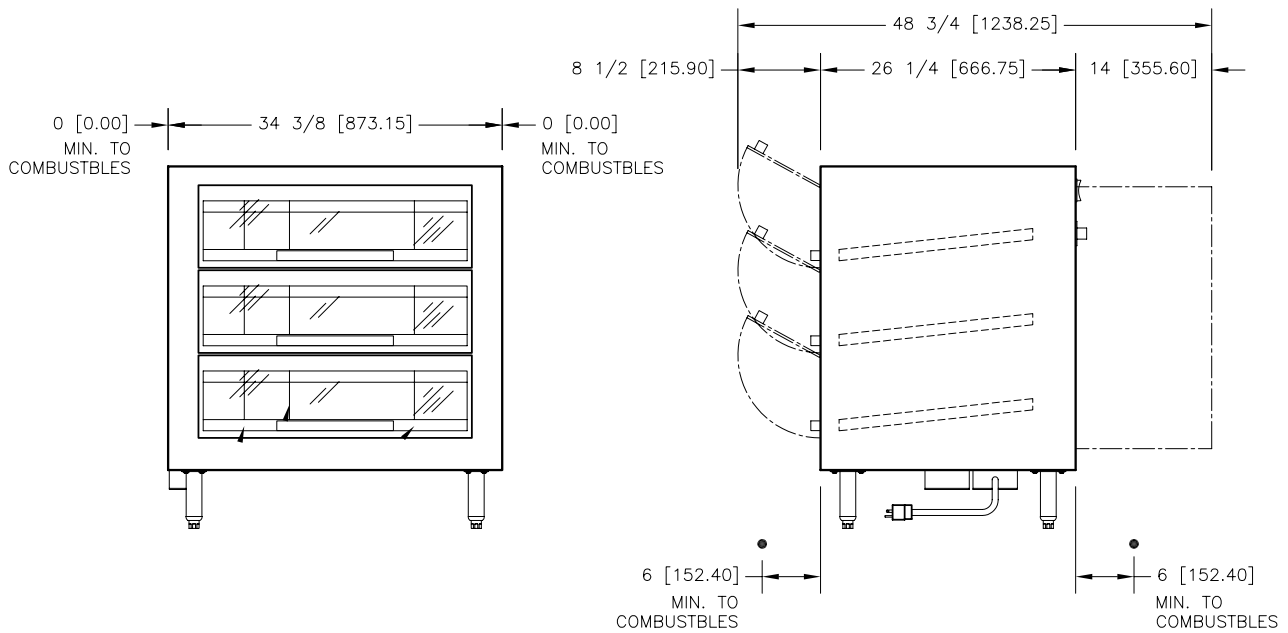

## 2-02.02 Clearances for RT5-HC

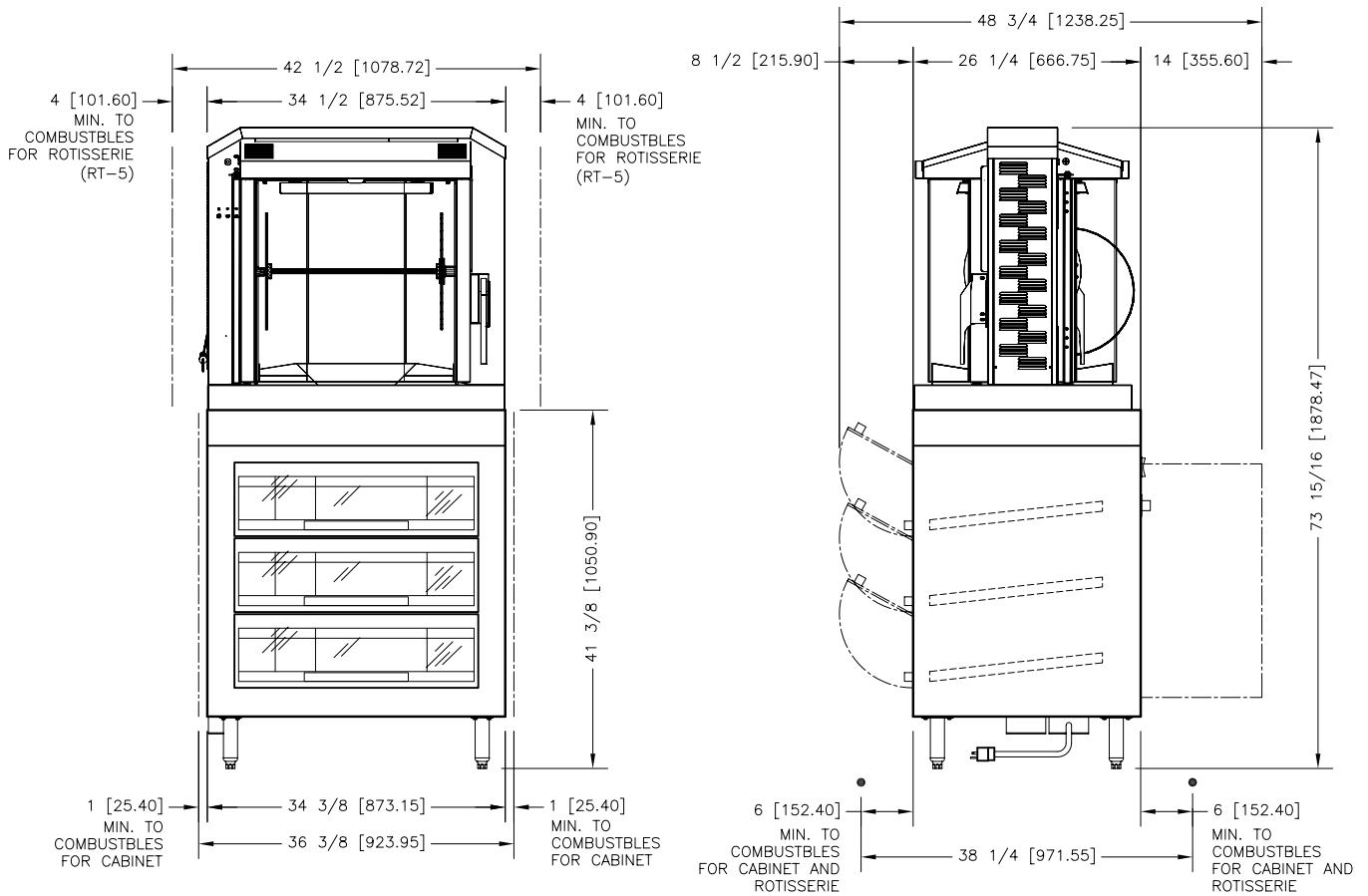

## 2-03. Electrical Requirements

**⚠ WARNING**

- **The unit must be adequately and properly grounded. Improper grounding may result in electrical shock. Always refer to your local electrical code to ensure proper grounding of this or any other electrical equipment. Always consult with an electrician or other qualified service person to ensure breakers and wiring are of sufficient rating and gauge for the equipment being operated.**
- Improper installation, adjustment, alteration, service or maintenance could result in death or serious injury, equipment/property damage, and void the warranty.

Electrical Requirements					
Voltage	Hz	Phase	Watts	Amps	Breaker
120	60	1	1290	11	15
240	60	1	1290	5.4	10
230	50	1	1290	5.6	10
380	50	1	1290	3.4	10

120V Unit is shipped with a 96" [2438mm] service cord and plug.

120V Plug Type- NEMA Configuration 5-15P



230V, 240V and 380V Units shipped with a 96" [2438mm] service cord only. Plug is to be supplied by customer. Consult an Electrician or other Qualified Service Personal.

## 2-04. Electrical Connections and Initial Set-up

### **⚠ WARNING**

- The unit must be properly grounded and all electrical specifications must be met during installation.
- Improper installation, adjustment, alteration, service or maintenance could result in death or serious injury, equipment/property damage, and void the warranty.

#### Step 1

Power  
Off

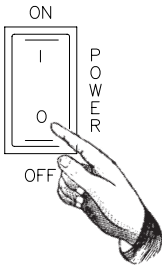

#### Step 2

Plug unit into dedicat-  
ed facility electrical  
receptacle.  
See Section 2-03.  
Electrical  
Requirements

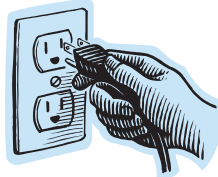

#### Step 3

Power  
On

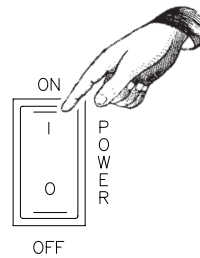

#### Step 4

Lights illuminate



#### Step 5

Rotate Thermostat  
Knob clockwise to  
setting "10". Allow to  
heat for 10 minutes.

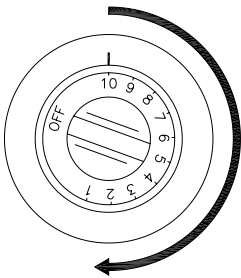

#### Step 6

View Thermometer  
to see temperature is  
increasing.

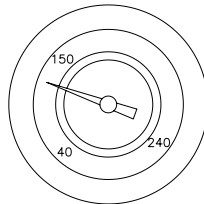

#### Step 7

If temperature is  
increasing the unit is  
heating correctly,  
continue to Step 7.

If temperature is not  
increasing continue  
to the  
Troubleshooting  
Section of this  
manual.

#### Step 8

Rotate Thermostat  
Knob counter-clock-  
wise to "OFF"  
position.

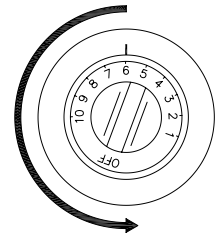

#### Step 9

Power  
Off

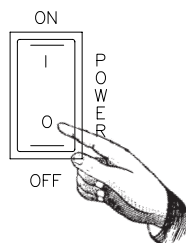

## 2-05. Cabinet Shelf Divider Installation

**CAUTION**

- If installing Shelf Dividers while the Shelf is in the unit, allow the Inner Cabinet and Shelves to thoroughly cool before installing the Shelf Dividers.

**NOTE:**

- Dividers may be installed before or after the Shelves have been installed in the unit. If installing Shelf Dividers while the Shelf is in the unit, allow the Inner Cabinet and Shelves to thoroughly cool before installing the Shelf Dividers.

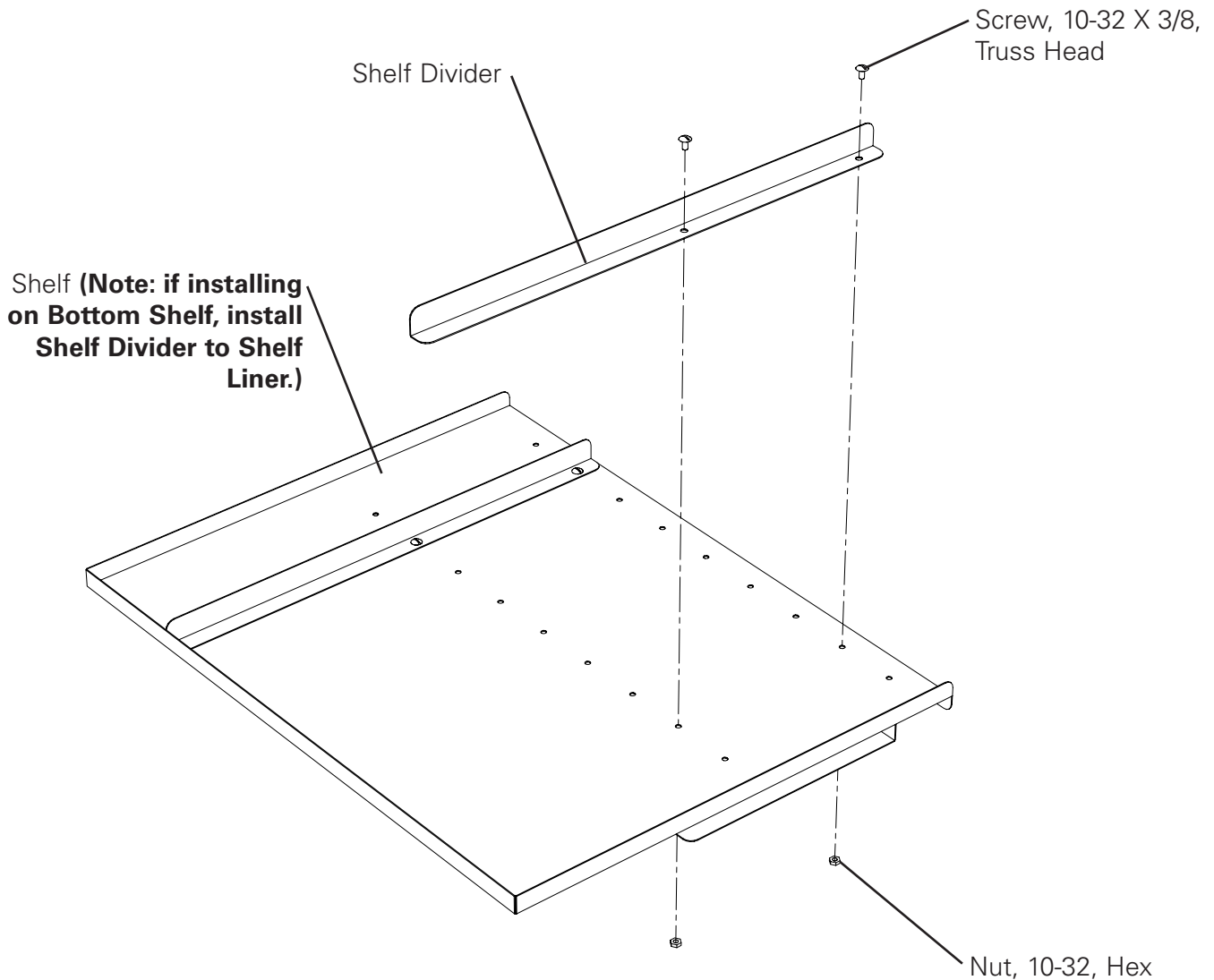

## 2-06. Cabinet Shelf Installation or Removal

**CAUTION**

- If removing Shelves from the unit, allow the Inner Cabinet and Shelves to thoroughly cool.

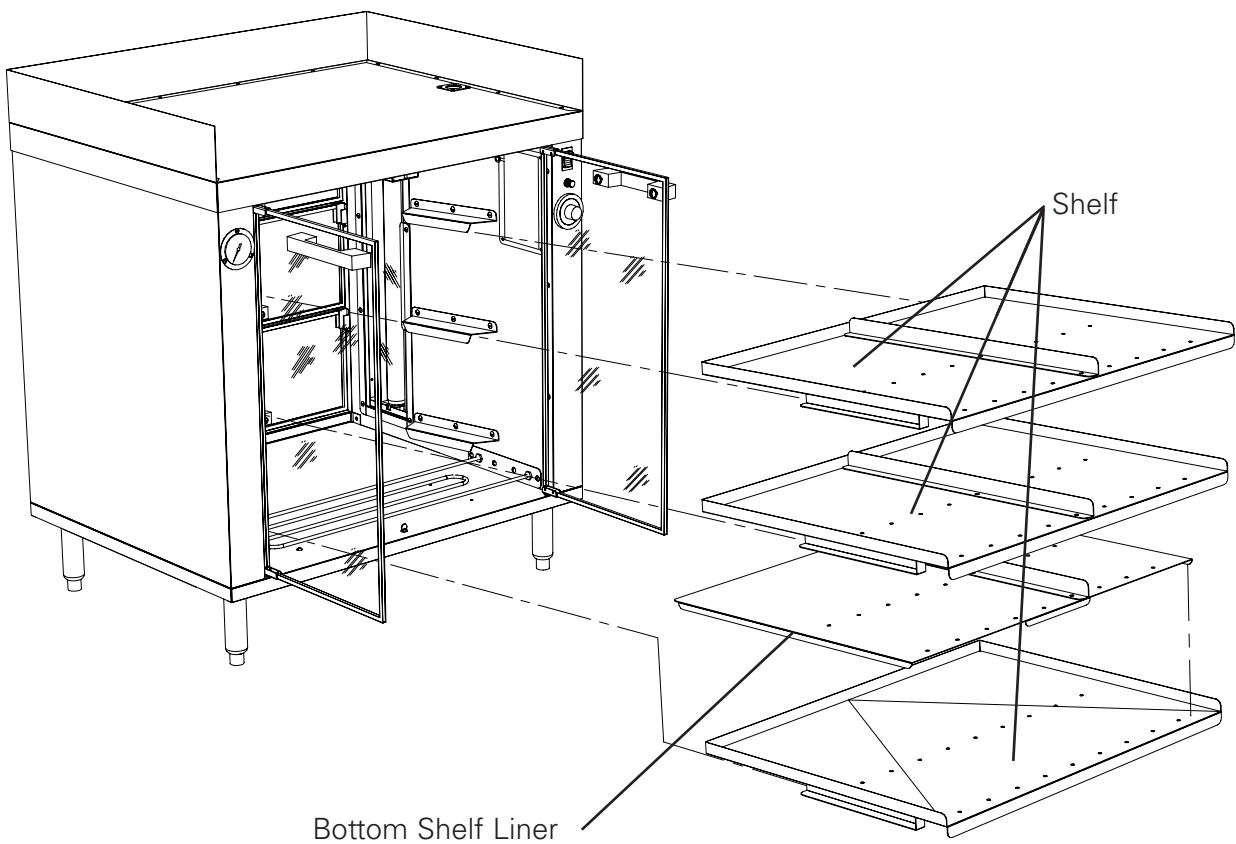

## 2-07. RT-5 Rotisserie Installation (RT5-HC Only)

**CAUTION**

- Exercise care when lifting or moving either unit. Please see Section 1-03.03 for Holding Cabinet weights and see the RT-5 Rotisserie operations and service manual for the RT-5 weights.

**NOTE:**

- The RT5-HC is designed to withstand the weight of the RT-5 and the product being cooked in it, along with the weight of the product being held in the RT5-HC.
- Do not use the GHC-5 for mounting a RT-5 Rotisserie.

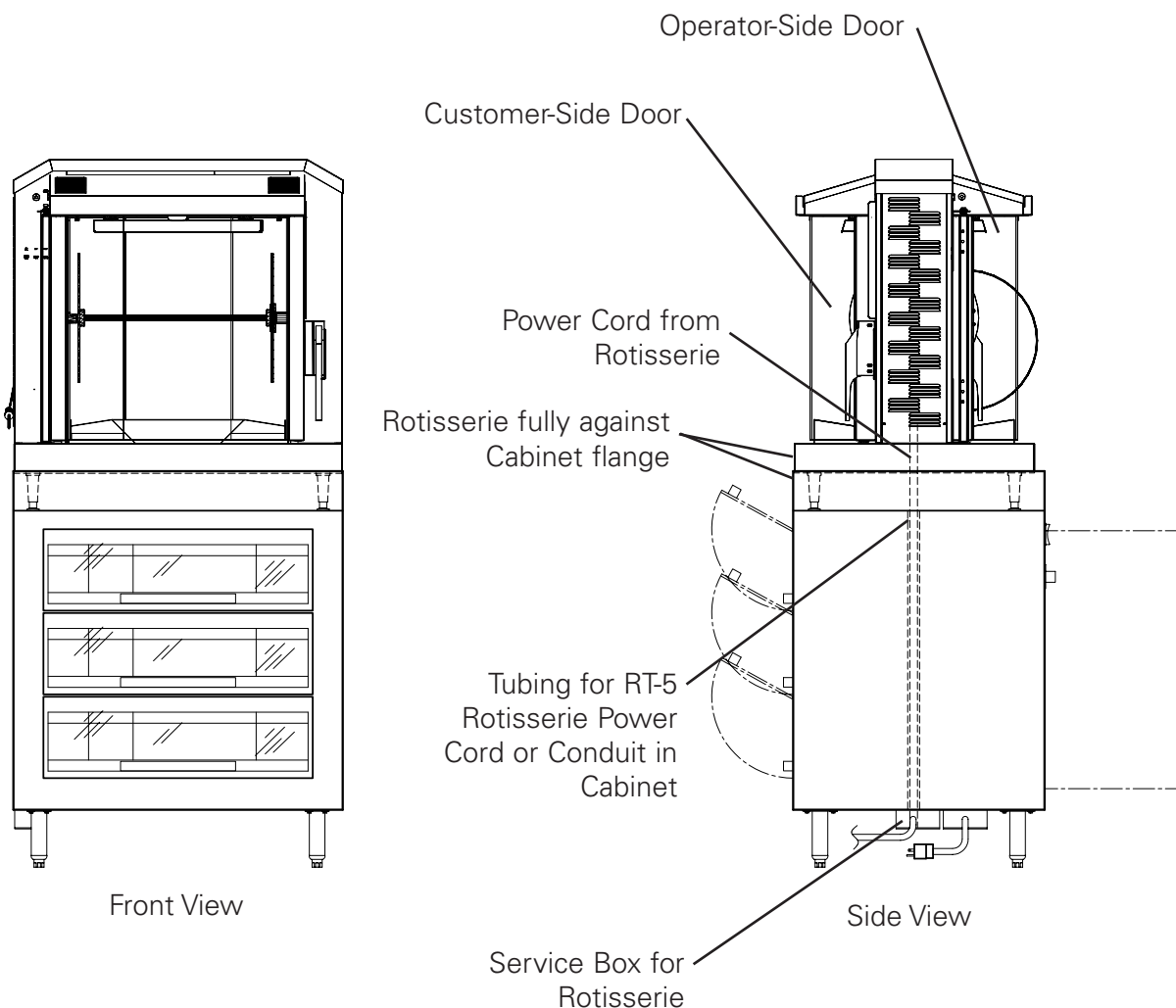

## 3. Overview

The following section provides a brief overview of the components, functions, and accessories of the RT5-HC and the GHC-5. Please review this section carefully before proceeding any further.



Shown Model: GHC-5

3-01. Cabinet Components

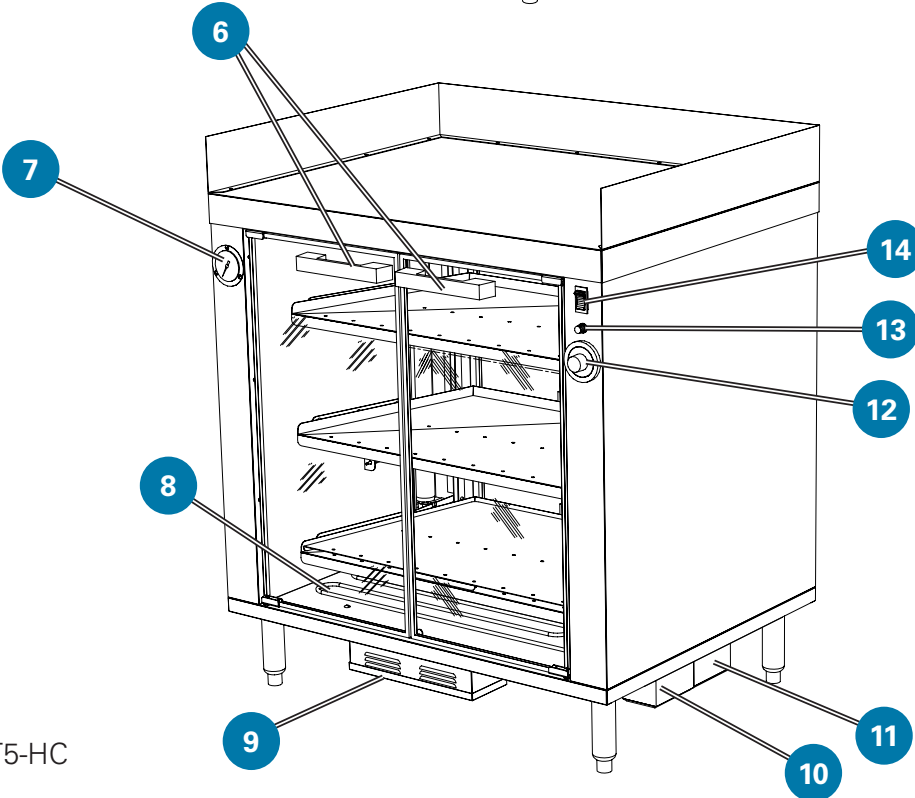
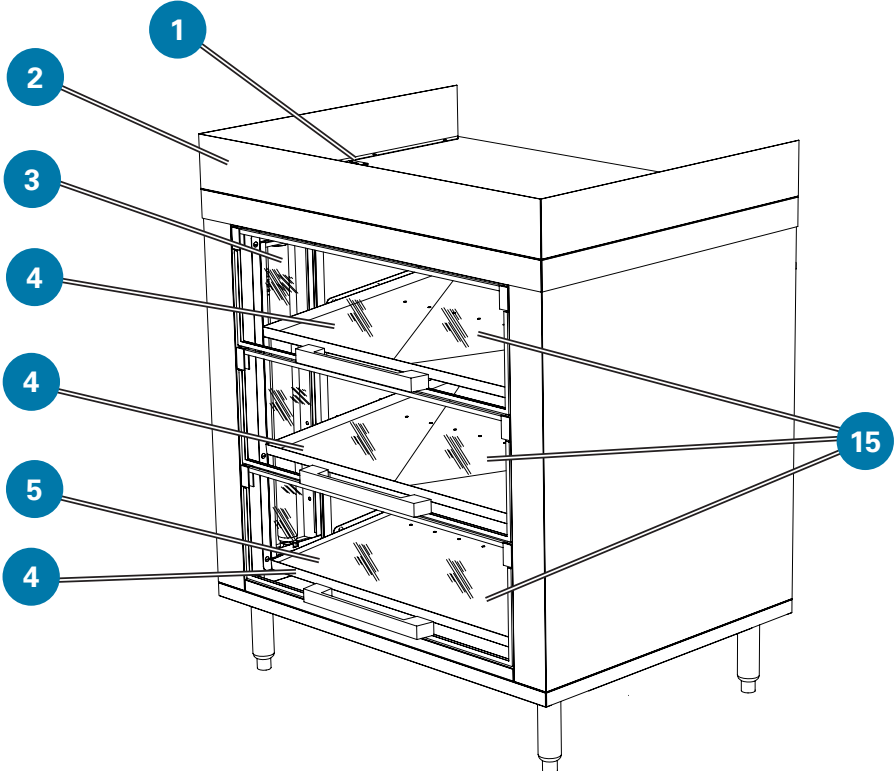

Shown Model: RT5-HC

## 3-01. Cabinet Components

Item	Description	Qty	Function
1*	RT-5 Service Tubing	1	Used to run the Power Cord or Conduit to the RT-5 Rotisserie. (RT5-HC only)
2*	RT-5 Flange	1	Used to hold the RT-5 Rotisserie in place on top of the cabinet. (RT5-HC only)
3	Lights	2	Used to illuminate the inner cabinet.
4	Shelf	3	Used to support packaged product.
5	Shelf Liner	1	Used to prevent packaged product on the bottom shelf from becoming too hot.
6	Operator-Side Door	2	Allows the operator access to the inside of the cabinet.
7	Thermometer	1	Used to display the actual inner temperature of the cabinet.
8	Element	1	Used to heat the cabinet.
9	Ballast	1	Used to supply power to the cabinet lights.
10	Service Box (Cabinet Power)	1	Used to connect power to the cabinet.
11*	Service Box (RT-5 Rotisserie)	1	Used to connect power to the RT-5 Rotisserie.(RT5-HC only)
12	Thermostat	1	Used to adjust the temperature in the cabinet.
13	Element Indicator Light	1	Used to indicate that the heating elements are on.
14	Power Switch	1	Used to turn power ON or OFF to the Cabinet.
15	Customer-Side Door	3	Allows the customer access to the packaged product.
16**	Shelf Divider	9	Used as a partition for package product.

\* - RT5-HC only

\*\* - Not Shown



**Notes:**

## 4. Operation

This section describes how to operate the unit.

### 4-01. Operation Procedure

#### Step 1

Power On

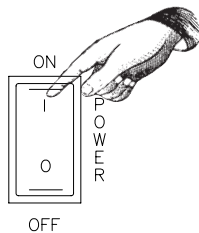

#### Step 2

Rotate Thermostat Knob clockwise to setting "10"

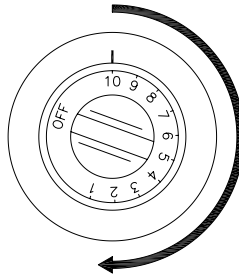

#### Step 3

Allow temperature in cabinet to reach 150°F (65.5°C).

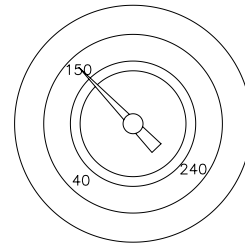

#### Step 4

Rotate Thermostat Knob counter-clockwise until Heat Indicator Light turns off, leave at this setting.

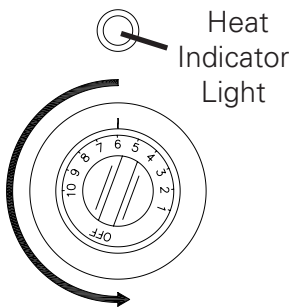

#### Step 5

Load the Cabinet with Cooked and Packaged Product.

#### Step 6

Periodically check the internal temperature of the product using a Hand-held Thermometer.

Adjust the Cabinet temperature if needed.

4-02. Normal Shut-Down

**Step 1**

Unload the cooked and packaged product from the Cabinet.

**Step 2**

Rotate Thermostat Knob counter-clockwise to the "OFF" setting

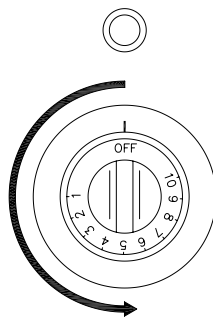

**Step 3**

Power Off

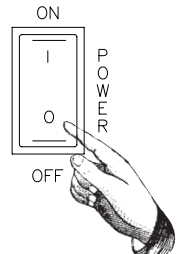

**Step 4**

Allow the unit to thoroughly cool. Then proceed to the cleaning section. See Section 5.

4-03. Emergency Shut-Down

In case of emergency, remove power to the unit by turning off the facility circuit breaker.

## 5. *Cleaning*

This section describes the proper cleaning of the unit.

### CAUTION

- During cleaning of the Giles Holding Cabinet (RT5-HC or GHC-5):
  - **DO NOT** steam clean.
  - **DO NOT** use cleaning products containing chlorine.
  - **DO NOT** use abrasive cleaning products, steel wool or scouring pads.
- Allow the unit to thoroughly cool before following this procedure.

### 5-01. Cleaning Procedure

#### CAUTION

- Allow the unit to thoroughly cool before following this procedure.
1. Perform a Normal Shut-Down procedure See Section 4.03, Normal Shut-Down.
  2. Allow the unit to thoroughly cool.
  3. Wear appropriate hand protection (if necessary) and remove the Shelves from the Holding Cabinet. Place items in the sink for cleaning.
  4. Clean the interior and exterior of the Holding Cabinet with soap and warm water. For difficult areas, use a mild degradable nontoxic degreaser (such as Clear Magic or Simple Green).
  5. Clean the glass parts of the Holding Cabinet with an ordinary window cleaner.
  6. Polish all stainless areas outside the Holding Cabinet with a good stainless polish.



**Notes:**

## 6. Troubleshooting

This section describes troubleshooting procedures for the GHC. Refer to the wiring diagrams in Section 8 for more detailed analysis.

**⚠ DANGER**

- Electrical troubleshooting procedures should be done **ONLY** by qualified service personnel. Death or serious injury will result from contact with energized electrical components.
- Failure to comply with these **DANGER** notices will result in death or serious injury, equipment/property damage, and void the warranty.

### 6-01. Troubleshooting Procedures

Problem	Probable Cause	Repair Procedure
<b>Holding Cabinet will not turn on</b>  Heat Indicator Light will not illuminate	a. Unit is not connected to power source	a. Call service technician to connect to proper power source.
	b. POWER switch defective	b. Call service technician to replace POWER switch.
	c. Improper supply voltage	c. Call service technician to connect proper supply voltage.
<b>Holding Cabinet will not heat</b>  Heat Indicator Light illuminated	a. Check to verify temp is set.	a. Check Thermostat.
	b. Loose wire	b. Call service technician to reposition wire. Refer to wiring diagram in Section 8.
	c. Bad element	c. Call service technician to replace element.
	d. Faulty temperature probe or thermostat.	d. Call service technician to replace thermostat.
<b>Lights not turning on</b>	a. Facility circuit breaker.	a. Reset facility circuit breaker.
	b. Blown bulb	b. Replace with 24" 120V 20W cool white fluorescent bulb. See Section 7-02.
	c. Faulty ballast	c. Call service technician.



**Notes:**

## 7. Parts List

This section lists various parts that are available for replacement on the unit.

### 7-01. Parts Ordering and Service Information

If you require assistance or need repairs, please contact your area developer for a service agency in your area. For further assistance, please contact the Giles Enterprises, Inc. factory at the following phone numbers:

**IN THE UNITED STATES, CANADA or MEXICO**

Please call 1-800-288-1555 during normal business hours, 8:00AM-5:00PM Central Time Zone. For emergency equipment repair service, after normal business hours, call 1-800-288-1555, extension 314.

**IN ALL OTHER COUNTRIES**

Please call 1-334-272-3528 during normal business hours, 8:00AM-5:00PM Central Time Zone; For emergency equipment repair service, after normal business hours call, 1-334-272-3528 extension 314.

**INTERNET**

Please visit our website on the world wide web at: [www.gilesent.com](http://www.gilesent.com).

The goal of the Giles team of professionals is to provide you with the highest quality of service and assistance. You can help us accomplish this by obtaining the following information and having it readily available when calling. The information is recorded on the Serial Plate attached to the rear of the unit.



The area below may be helpful in recording information for use as a quick reference.

**Model Number:** \_\_\_\_\_

**Serial Number:** \_\_\_\_\_

**Phase:** \_\_\_\_\_

**Voltage:** \_\_\_\_\_

**Nature of Problem:** \_\_\_\_\_

7-02. Light Replacement

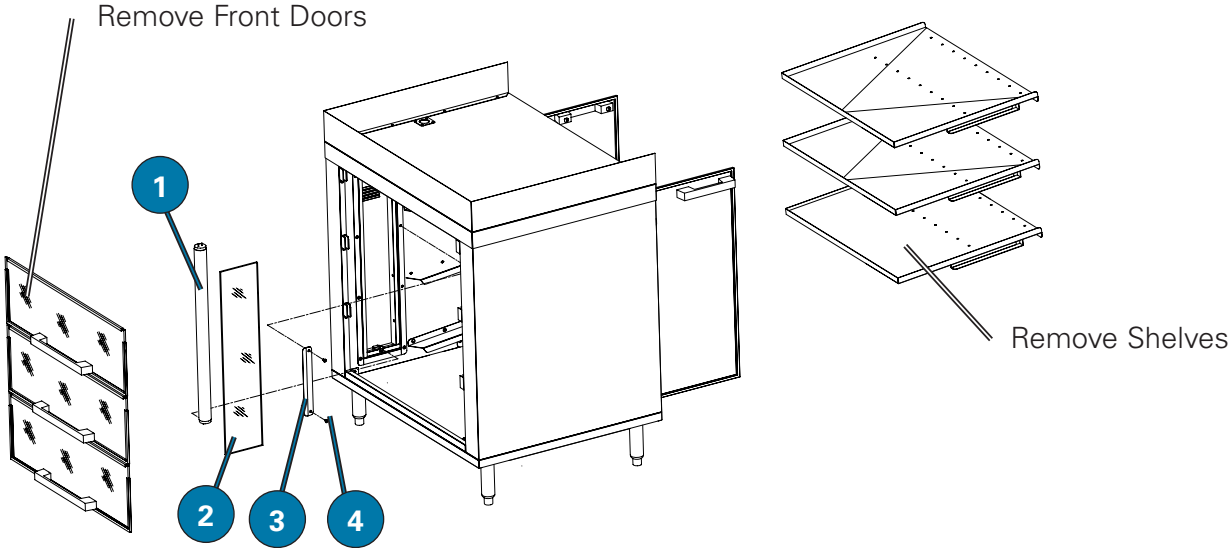

7-03. Ballast and Leg Replacement

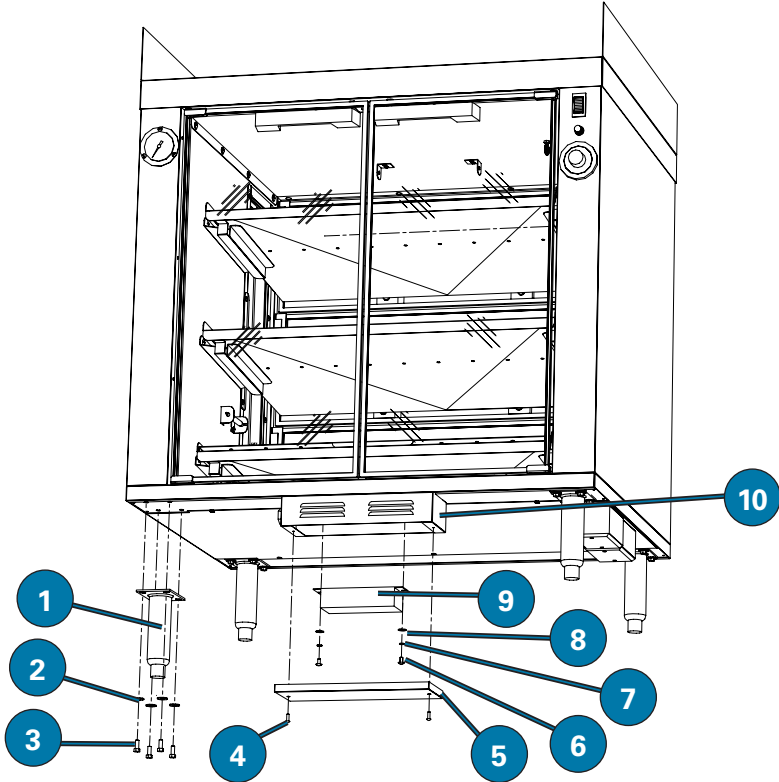



## 7-02. Parts List for Light Replacement

Item	Part No.	Qty.	Description
1	40015	2	LIGHT, FLUORESCENT 20W 24", COOL WHITE
2	40011	1	COVER, LIGHT HOUSING GLASS
3	33966	2	BRACKET, LIGHT HOUSING GLASS MOUNT
4	----	4	SCREW, 8-32 X 3/8, TRS HD SLT, SS

## 7-03. Parts List for Ballast and Leg Replacement

Item	Part No.	Qty.	Description
1	46737	4	LEG, 6 IN, ADJUSTABLE, SHELL WITH BASE
2	----	16	WASHER, 1/4, FLAT, USS
3	----	16	SCREW, 1/4-20 X 5/8, HX HD, ZN
4	----	2	SCREW, #8 X 1/2
5	34574	1	COVER, BALLAST BOX
6	----	2	SCREW, 10-32 X 3/8, TRS HD SLT, SS
7	----	2	WASHER, LOCK, #10, ZN
8	----	2	WASHER, #10, USS, ZN
9	40014	1	BALLAST, 120V, 24, 20W, FOUR BULB
10	39266	1	BALLAST BOX, RT-5-HC, WELD ASSY

\* -Not shown

7-04. Door and Shelf Replacement

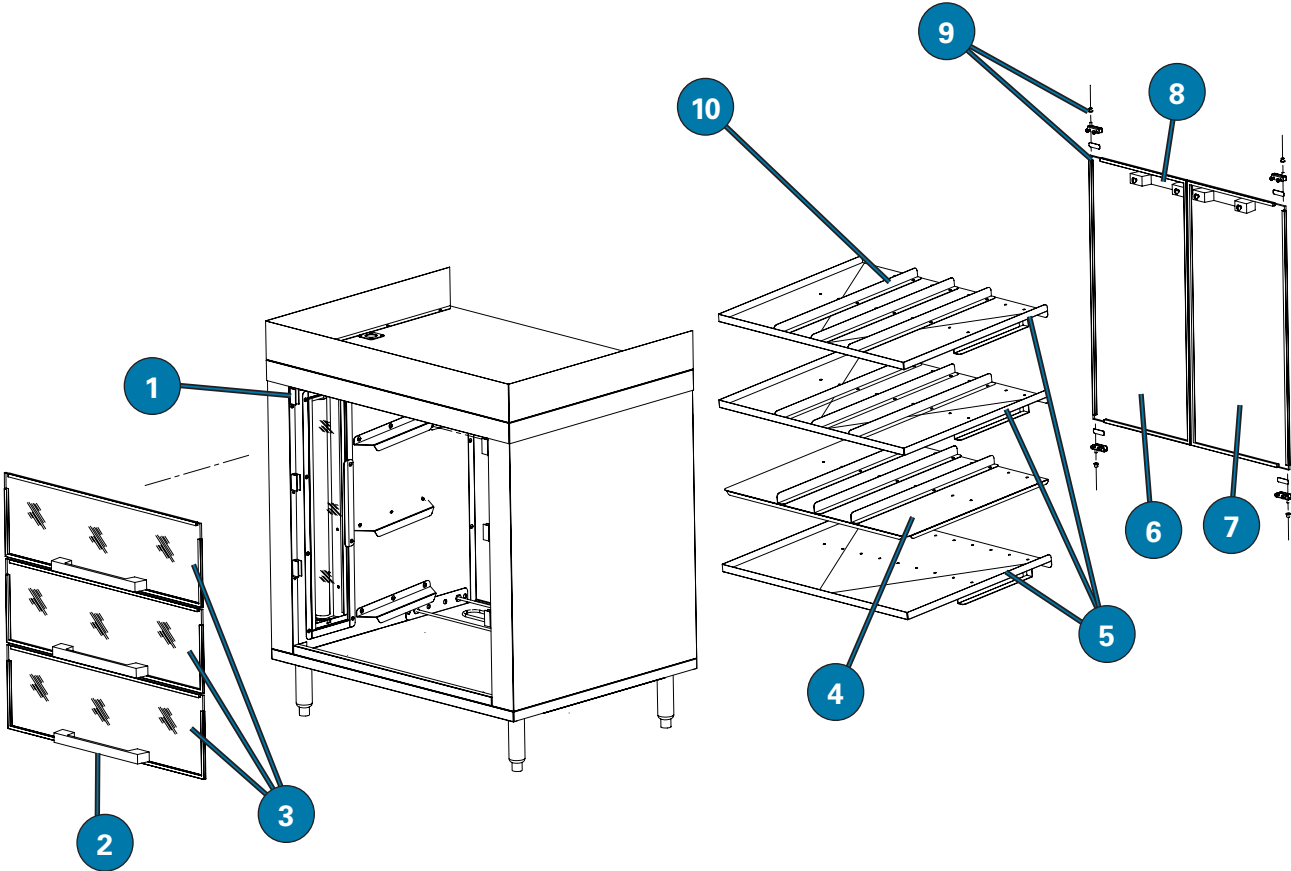

## 7-04. Parts List for Door and Shelf Replacement

Item	Part No.	Qty.	Description
1	70587	3	KIT, CR5-HC FRONT DOOR HINGE REPLACEMENT
2	42829	3	HANDLE, 12-1/4" FRONT DOOR (CR-HC)
3	33925	3	FRONT GLASS DOOR, ASSY (HANDLE INCLUDED)
4	34382	1	LINER, SHELF, CR5-HC
5	33799	3	SHELF, WELD ASSY
6	33932	1	REAR GLASS DOOR, ASSY, RIGHT (HANDLE INCLUDED)
7	33931	1	REAR GLASS DOOR, ASSY, LEFT (HANDLE INCLUDED)
8	42830	2	HANDLE, 7-5/8" REAR DOOR (CR-HC)
9	40013	2	HINGE, GLASS DOOR, REAR, CR5-HC
10	33766	10	DIVIDER, SHELF

7-05. Component Replacement

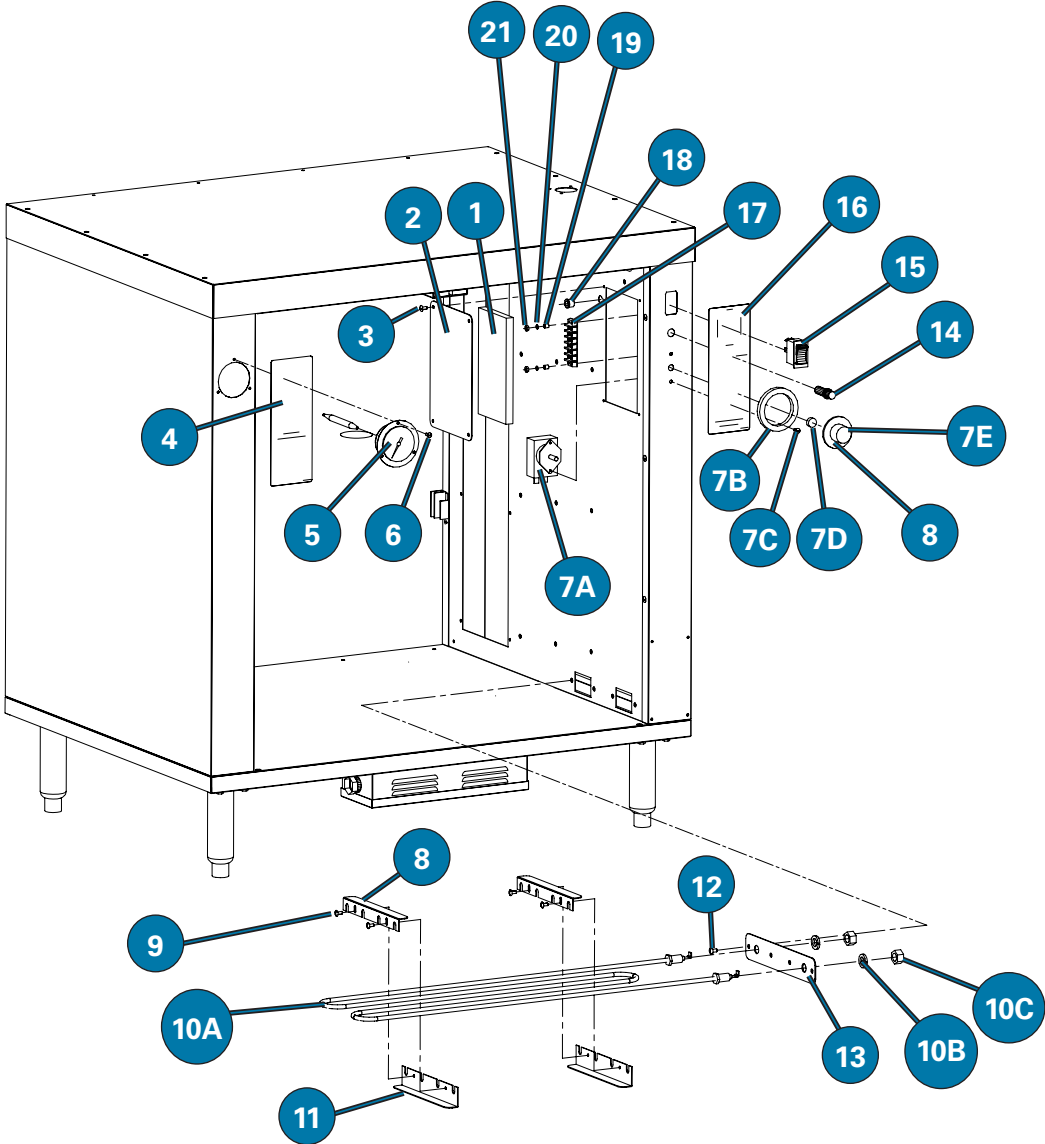

## 7-05. Parts List for Component Replacement

Item	Part No.	Qty.	Description
1	33953	1	INSULATION, CONTROL ACCESS PANEL
2	33772	1	PANEL, CONTROL ACCESS
3	10800	4	SCREW, 8-32 X 3/8, TRS HD SLT, SS
4	69028	1	LABEL, CABINET TEMPERATURE (CR5-HC)
5	40018	1	THERMOMETER, 40 TO 240DEG F
6	10300	3	SCREW, 6-32 X 3/8, TRS HD SLT, S/S
7A	24024	1	THERMOSTAT, ROBERTSHAW,100-200 DEG
7B	N/A	1	BEZEL, COMES WITH THERMOSTAT
7C	N/A	1	SCREW, COMES WITH THERMOSTAT
7D	N/A	1	STOP, COMES WITH THERMOSTAT
7E	N/A	1	KNOB, COMES WITH THERMOSTAT
8	20025	1	PLATE, KNOB DIAL 1-10, GHM
9	10675	4	SCREW, 8-32 X 1/4 TRS HD SLT SS
10A	20214	1	ELEMENT,CR5-HC,240V,1250 WATTS
10A	21677	1	ELEMENT, ROUND, 1250W, 120V, CR5-HC
10B	N/A	1	LOCK WASHER, COMES WITH ELEMENT
10C	N/A	1	NUT, ELEMENT, COMES WITH ELEMENT
11	33770	2	BRACKET, ELEMENT HOLDING
12	11475	2	SCREW, 10-32 X 3/8, TRS HD SLT, SS
13	33769	1	BRACKET, ELEMENT MOUNTING
14	22325	1	LIGHT, PILOT, 115V, ROUND, RED
15	21190	1	SWITCH, ROCKER, ON-OFF, 250V, 20A, DPST
16	69027	1	LABEL, CONTROL PANEL (CR5-HC)
17	23751	1	TERMINAL BLOCK, MA106,6 POLE
18	40450	2	BUSHING, SNAP 1/2"
19	10152	2	SPACER, #6 X 1/4, PLASTIC
20	10600	2	WASHER, LOCK, #6, ZN
21	10525	2	NUT, 6-32, HEX, ZN



7-06. Light Housing Assembly

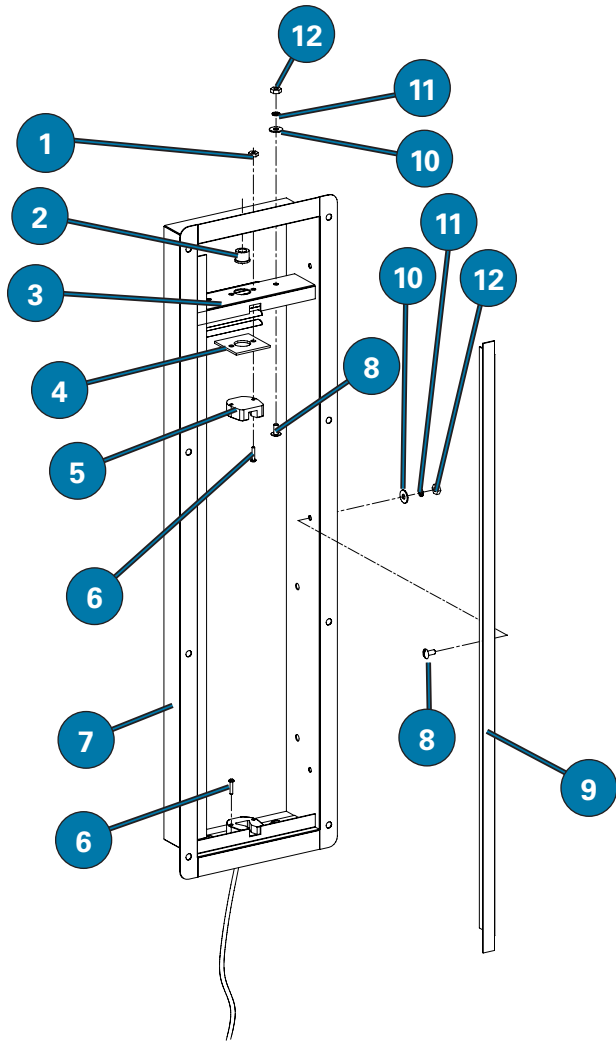

## 7-06. Parts List for Light Housing Assembly

Item	Part No.	Qty.	Description
1	10175	4	NUT, 5-40 HX ZN
2	40450	2	BUSHING, SNAP 1/2"
3	33760	2	ANGLE, LIGHT HOUSING TOP & BOTTOM
4	34594	2	SHIM, LAMPHOLDER
5	40627	2	LAMPHOLDER, FLUORESCENT MED BI-PIN W/LEADS
6	10086	4	SCREW, 4-40 X 3/4 RND HD SLT -ZN
7	33798	1	LIGHT HOUSING, WELDMENT
8	10800	10	SCREW, 8-32 X 3/8, TRS HD SLT, SS
9	33916	2	ANGLE, LIGHT HOUSING FRONT
10	11225	10	WASHER, #8 US FLAT ZN
11	11275	10	WASHER, LOCK, #8, ZN
12	11150	10	NUT, 8-32, HEX, ZN



**Notes:**

## 8. Wiring Diagram

The following section contains various Wiring Diagrams for the RT5-HC and GHC-5 units. Please check the Serial Plate, as shown below, for the unit's Model Name, Voltage, Hertz, and Phase.



Shown Model: GHC-5

Serial Plate

## 8-01. Wiring Diagram RT5-HC & GHC-5 120/60/1

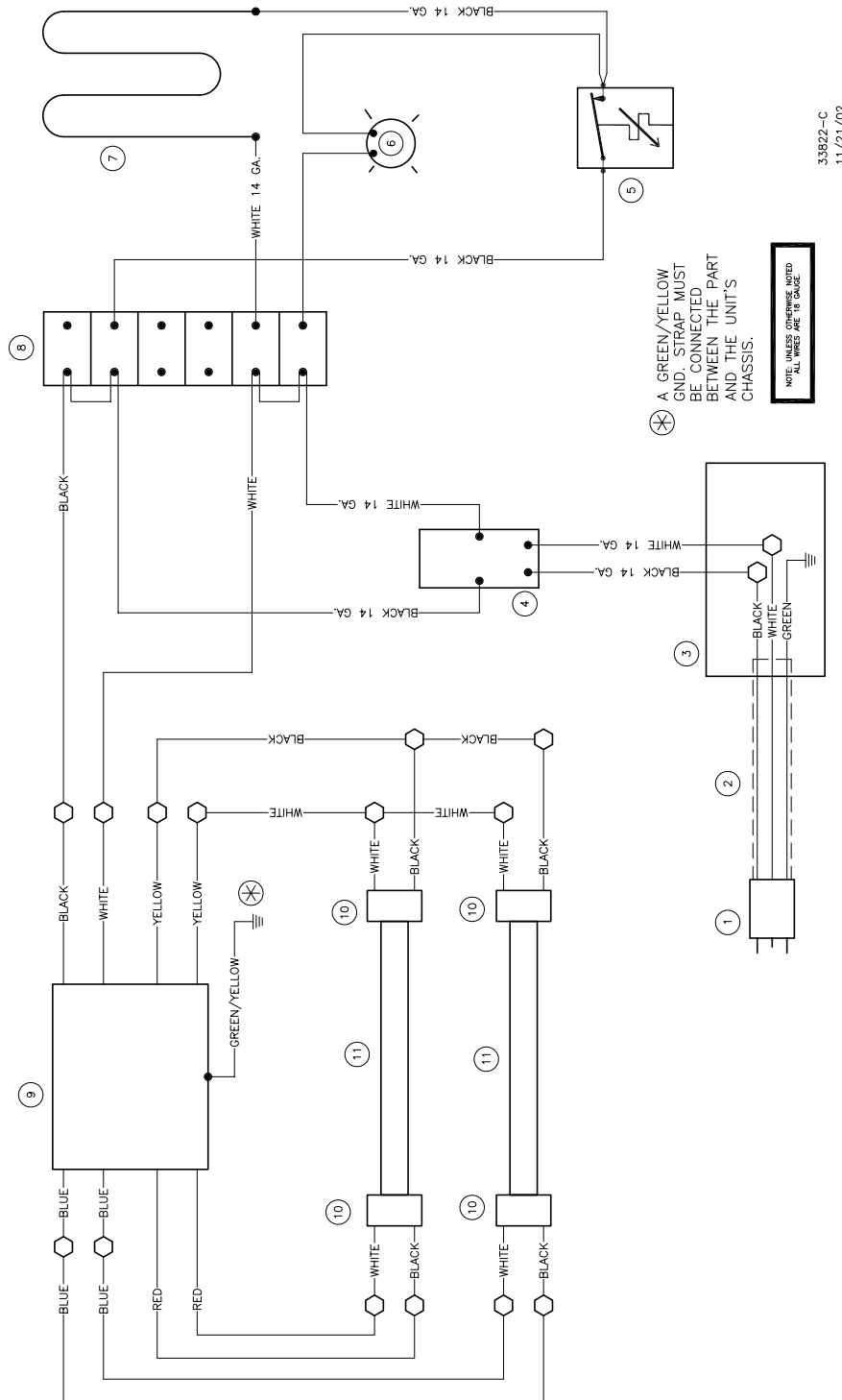

WIRING DIAGRAM RT5-HC 120/60/1

## 8-01. Parts List for Wiring Diagram RT5-HC & GHC-5 120/60/1

Item	Part No.	Qty.	Description
1	22450	1	PLUG, 15A 125V 2PL 3WR 1PH STR
2	20150	96"	CABLE, SO 14-3
3	33203	1	SERVICE BOX, 1/2" w/0.840 HOLE, FSH-5
4	21190	1	SWITCH, ROCKER, ON-OFF, 250V, 20A, DPST
5	24024	1	THERMOSTAT, ROBERTSHAW,100-200 DEG
6	22325	1	LIGHT, PILOT, 115V, ROUND, RED
7	21677	1	ELEMENT, ROUND, 1250W, 120V, CR5-HC
8	23751	1	TERMINAL BLOCK, MA106,6 POLE
9	40014	1	BALLAST, 120V, 24, 20W, FOUR BULB
10	40627	4	LAMPHOLDER, FLUORESCENT MED BI-PIN W/LEADS
11	40015	2	LIGHT, FLUORESCENT 20W 24", COOL WHITE

## 8-02. Wiring Diagram RT5-HC & GHC-5 230/50/1

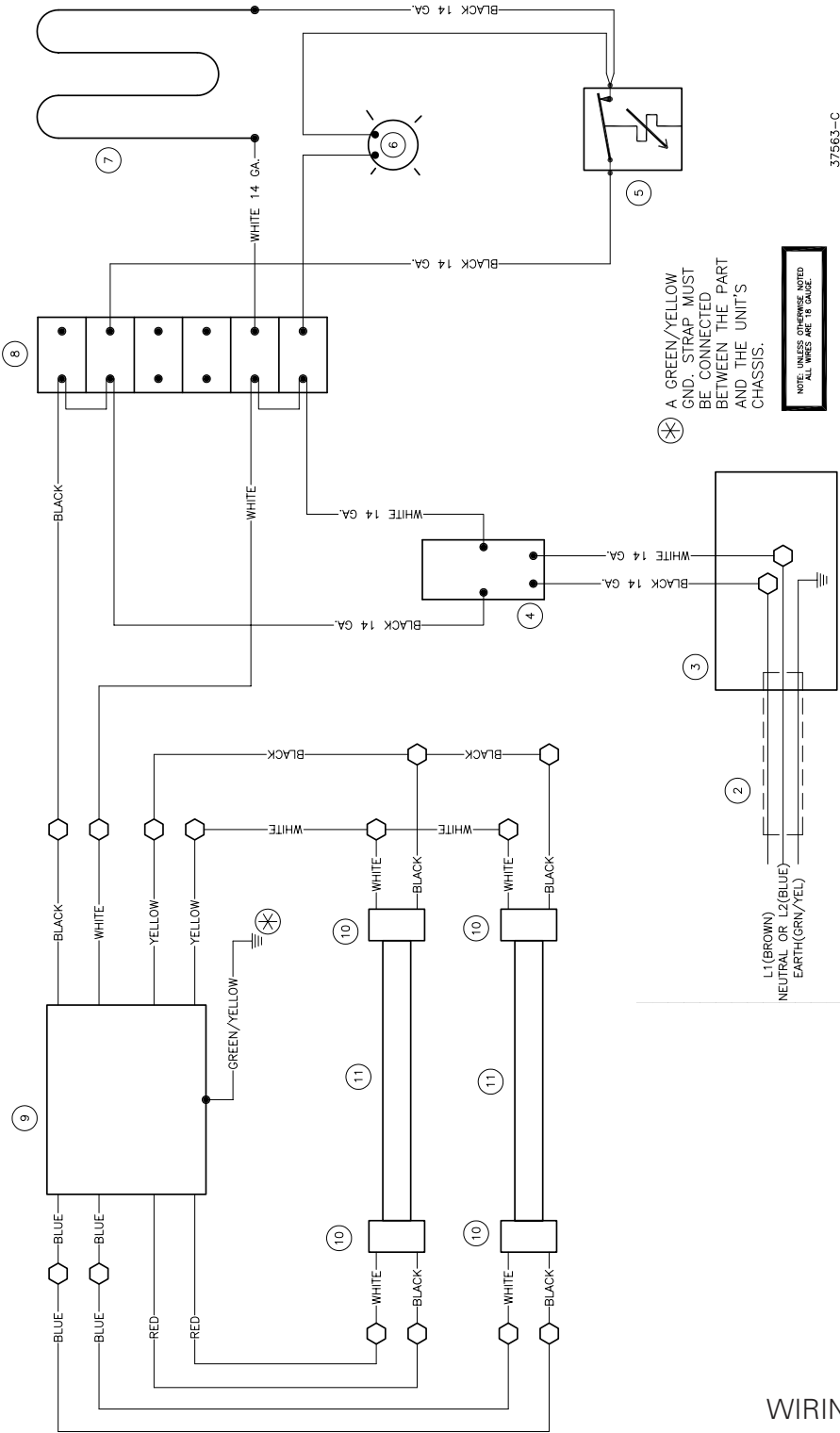

37563-C  
11/21/02

WIRING DIAGRAM RT5-HC 220-240/50/1 AND 208-240/60/1

WIRING DIAGRAM P/N:  
37563-C

## 8-02. Parts List for Wiring Diagram RT5-HC & GHC-5 230/50/1

Item	Part No.	Qty.	Description
1	-----	--	-----
2	20177	8	WIRE,3X4.00mm,CE,3 WIRE RUBBER CABLE,
3	33203	1	SERVICE BOX, 1/2" w/0.840 HOLE, FSH-5
4	21190	1	SWITCH, ROCKER, ON-OFF, 250V, 20A, DPST
5	24024	1	THERMOSTAT, ROBERTSHAW,100-200 DEG
6	22300	1	LIGHT, PILOT, 250V, ROUND, RED
7	20214	1	ELEMENT,CR5-HC,240V,1250 WATTS
8	23751	1	TERMINAL BLOCK, MA106,6 POLE
9	20212	1	BALLAST,240V,50/60HZ,2-20W FLOUR BULBS
10	40627	4	LAMPHOLDER, FLUORESCENT MED BI-PIN W/LEADS
11	40015	2	LIGHT, FLUORESCENT 20W 24", COOL WHITE



**Notes:**





**Giles Enterprises, Inc.**

2750 Gunter Park Drive West • Montgomery, Al 36109 USA  
(334) 272-1457 • Service Hotline 1-800-554-4537 (USA & Canada Only) • FAX (334) 272-3561 • [www.gilesent.com](http://www.gilesent.com)

Form No. 65968 (Release date: 01/98)(Revision Date: 11/1/2004)(Rev B)(ECO0910)(CSY)