



Item #: \_\_\_\_\_

Model: **Models: GPD48, GPD60**

Product Name: Pyro Deck

Gas Pizza/Baking Oven



*Model GPD60  
(shown with optional stainless steel legs)*

**Specification:**

Garland Pyro Deck Gas Pizza/Baking Oven, Model GPD48 with 96,000BTU, (28.1kW), or GPD60 with 122,000BTU, (35.7kW), input per hour, per deck to Pyrorock oven hearth. Full-width oven door, flush to hearth for easy loading/unloading. "Cool Touch" door handle for safe, comfortable operation. Heat damper system to regulate top to bottom heat. Easy access doors to burner and gas valve. Stainless steel front and sides, aluminized top, black powder coat epoxy legs. UL, CUL Classified and NSF listed.

**Standard Features:**

- 1½" (38mm) thick Pyrorock Hearth
- 122,000 BTU (35.7 kW) input - GPD60  
96,000 BTU (28.1 kW) input - GPD48
- Removable aluminized steel flame spreaders (2)
- "Snap" throttle thermostat for quick recovery (650°F/ 345°C maximum temperature)
- 100% automatic pilot safety shut-off valve
- Stainless steel front and sides
- Open door lies flush to hearth for easy loading and unloading.
- "Cool Touch" door handle for safe, comfortable operation.
- Easy-access door to burner compartment and gas control valve
- 48" (1219mm) x 36" (914mm) and 60" (1524mm) x 36" (914mm) hearth models to match production needs
- 8" (203mm) high oven cavity
- Heat damper system provides top to bottom heat adjustment within cooking chamber
- Canopy Flue Diverter
- 3/4" NPT manifold connection - right rear and side connection
- One year limited parts and labor warranty

**Optional Features:**

- Direct flue diverter replaces canopy diverter and allows oven to be connected to an approved 6" (152mm) flue pipe and vented to exterior of building.
- Double stack models available (GPD48-2 and GPD60-2)
- 10-gauge, stainless steel legs (specify single or double deck)
- Stainless steel top



Garland Commercial Industries, Inc.  
185 East South Street  
Freeland, Pennsylvania 18224  
Phone: (570) 636-1000  
Fax: (570) 636-3903

Garland Commercial Ranges Ltd  
1177 Kamato Road, Mississauga, Ontario  
L4W 1X4 CANADA  
Phone: 905-624-0260  
Fax: 905-624-5669

Enodis UK LTD  
Swallowfield Way, Hayes, Middlesex  
UB3 1DQ ENGLAND  
Telephone: 081-561-0433  
Fax: 081-848-0041

GARLAND® GAS  
Pyro Deck Gas Pizza/Baking Oven

Models: GPD48, GPD60



Item #: \_\_\_\_\_  
 Model: Models: GPD48, GPD60  
 Product Name: Pyro Deck  
 Gas Pizza/Baking Oven

Gas Input ratings shown here are for installations up to 2,000-ft. (610m) above sea level. Specify altitudes over 2,000 ft.

Commercial cooking equipment requires an adequate ventilation system. For additional information, refer to the National Fire Protection Association's standard NFPA96, (NOTE: For North America only)

Installation Notes:	
Non-Combustible & Combustible Wall Clearances	
Sides	Back
1" (25mm)	6" (152mm)
Entry Clearance:	
Crated	Uncrated
35" (889mm)	26" (660mm)
Manifold Operating Pressure:	
Natural	Propane
6" WC (15mbar)	10" WC (25mbar)
Please specify gas type when ordering	
NOTE: Data applies only to North America	

INPUT SPECIFICATIONS Natural Or Propane			
MODEL	BTU/HR	KW	GAS INLET
GPD48	96,00	28.1	3/4" N.P.T.
GPD60	122,000	35.7	3/4" N.P.T.
GPD48-2	192,000	56.2	1" N.P.T.
GPD60-2	244,000	71.4	1" N.P.T.

MODEL NUMBER	Interior Dimensions: In (mm)			Exterior Dimensions In (mm)		
	W	H	D	W	H (w/NSF legs)	D
GPD48	48 (1220)	8 (203)	36 (914)	63 (1600)	52-3/4 (1340)	45-1/4 (1149)
GPD60	60 (1524)	8 (203)	36 (914)	75 (1905)	52-3/4 (1340)	45-1/4 (1149)
GPD48-2	48 (1220)	8 (203)	36 (914)	63 (1600)	62-1/2 (1588)	45-1/4 (1149)
GPD60-2	60 (1524)	8 (203)	36 (914)	75 (1905)	62-1/2 (1588)	45-1/4 (1149)

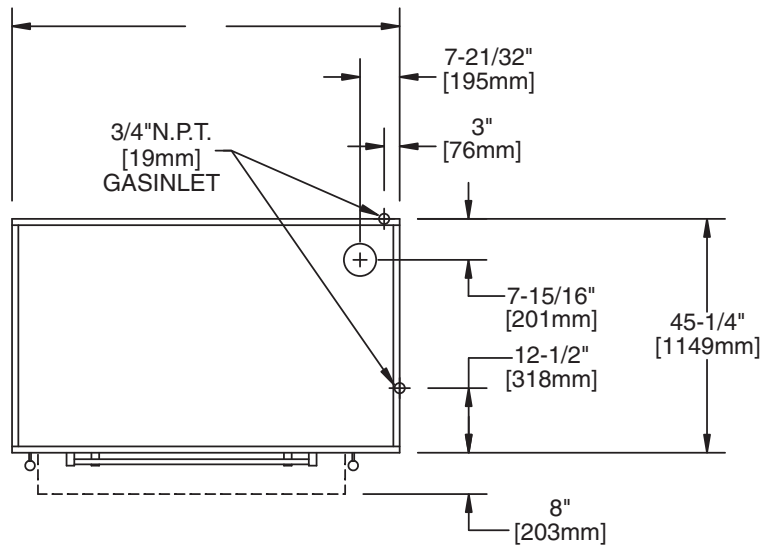
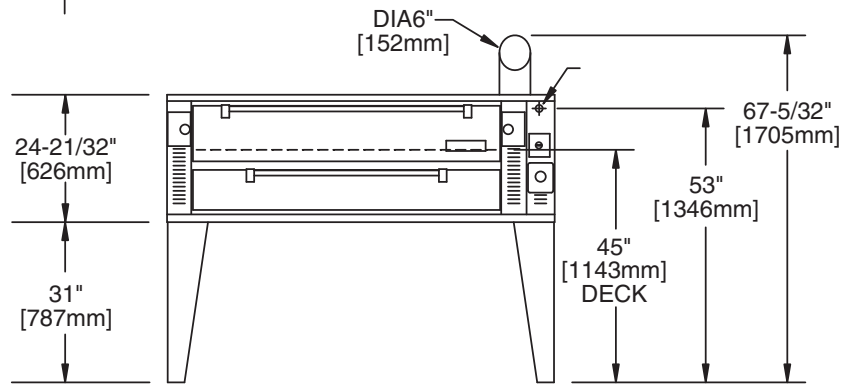
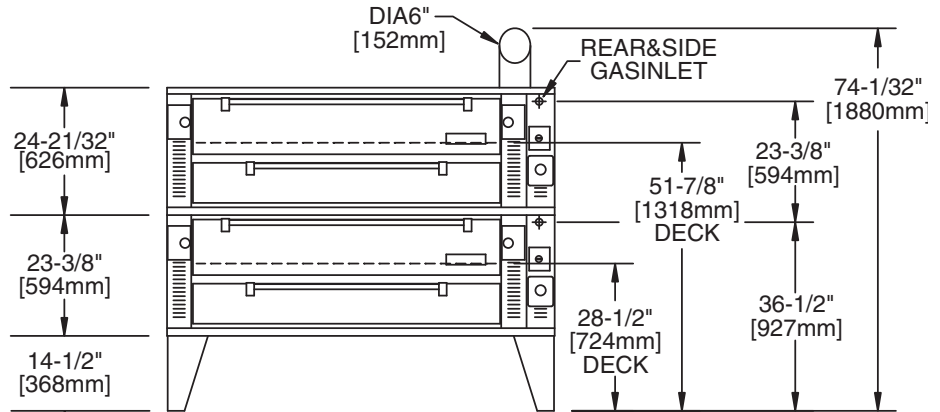

Continuous product improvement is a Garland policy.