

*Model G56PT*
**Specifications:**

Unique energy delivery system driven by controlled hot air flow designed for high volume operation. Offers minimum preheat time; no recovery time; consistent selected temperatures; high quality production, and menu versatility. Available in natural or propane gas.

**Standard Features:**

- Stainless Steel Front, Sides, Top, and Legs
- Porcelainized Control Panel
- Full Deck Width, Balanced Spring-Loaded Door
- Stainless Steel Perforated Deck
- Adjustable Legs
- Electronic Ignition
- Snap Action Thermostat (550° F Max.)
- Heat Control Damper System
- Forced Air Combustion Burner; 80,000 BTU
- Single Speed Fan with ¾ HP Motor
- 56"W x 36"D Deck Surface
- 63"W x 45"D Floor Space
- 53"W x 7½"H Door Opening
- One Year Limited Parts and Labor Warranty (USA & Canada only)

**Optional Features:**

- Stainless Steel Back
- Direct Connect Vent - No charge

*Model G56PT/B*

Garland Commercial Industries, Inc.  
 185 East South Street  
 Freeland, Pennsylvania 18224  
 Phone: (570) 636-1000  
 Fax: (570) 636-3903

Garland Commercial Ranges Ltd  
 1177 Kamato Road, Mississauga, Ontario  
 L4W 1X4 CANADA  
 Phone: 905-624-0260  
 Fax: 905-624-5669

Enodis UK LTD  
 Swallowfield Way, Hayes, Middlesex  
 UB3 1DQ ENGLAND  
 Telephone: 081-561-0433  
 Fax: 081-848-0041



Item #: \_\_\_\_\_

Models: G56PB, G56PT, G56PT/B

Product Name: Air-Deck™ Gas Deck Oven

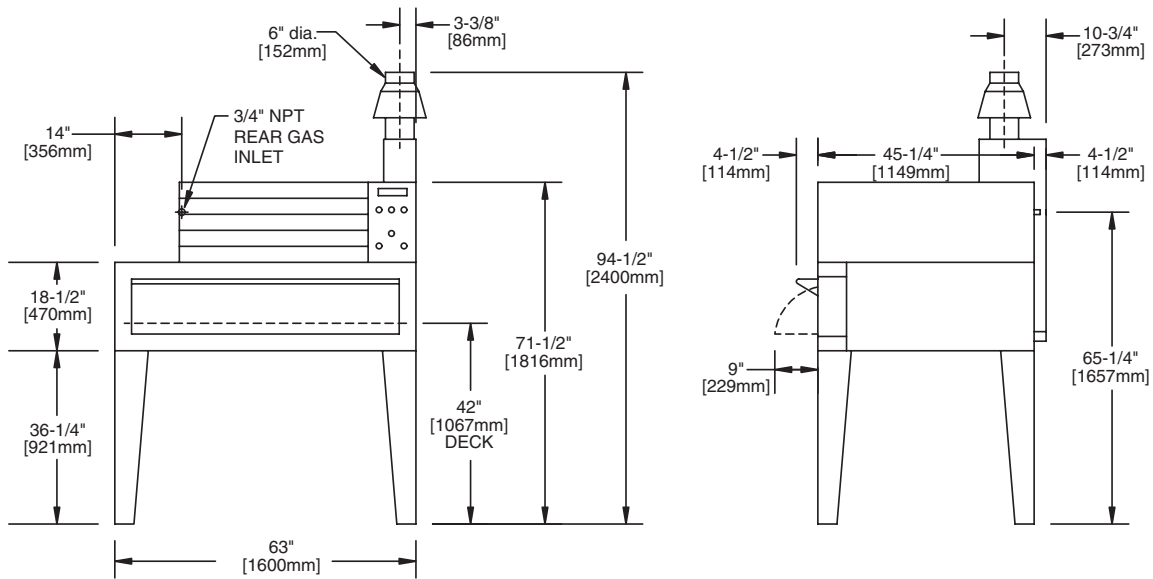

Single deck with top power module and Direct Connect Venting.

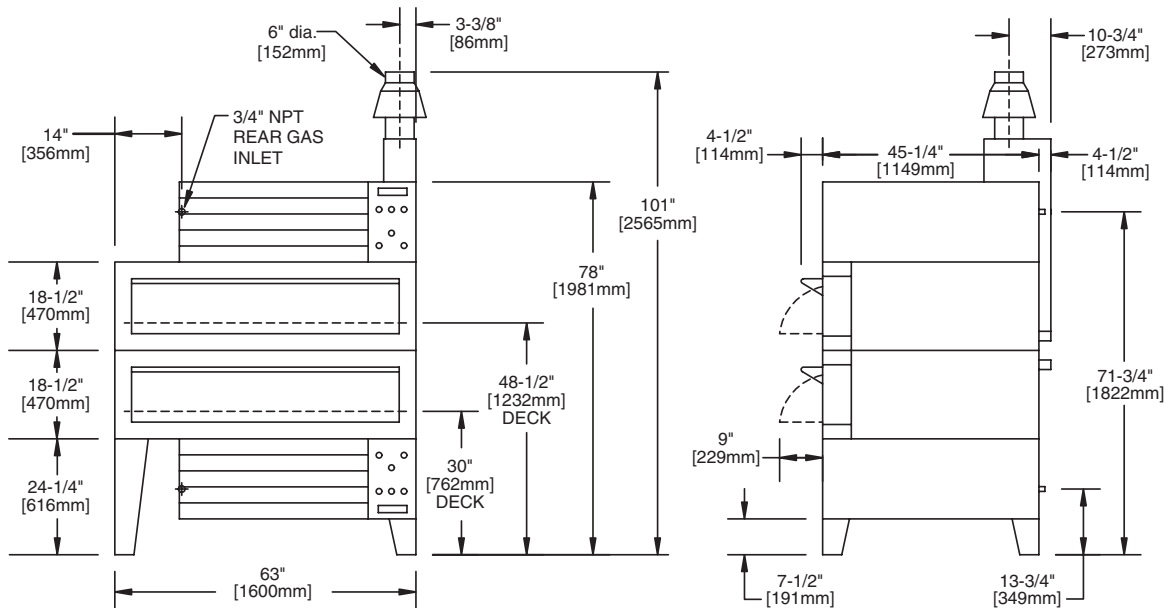

Double Deck: (1) top power module, (1) bottom power module and Direct Connect Venting.

MODEL	INPUT (BTU)	DECK AREA	PIZZA CAPACITY	MOTOR	SHIPPING WT.
G56PB	80,000	14.0 Sq. Ft.	(6) 18"	120V, 1PH, 60Hz 15 Amps (1 per deck)	1000 lbs. 455 kg
G56PT	80,000	14.0 Sq. Ft.	(6) 18"		1000 lbs. 455 kg
G56PT/B	160,000	28.0 Sq. Ft.	(12) 18"		2@1000 lbs. 910 kg

Gas input ratings shown here are for installations tip to 2,000 feet (610mm) above sea level. BTU input ratings must be derated for high altitude installations.

OPERATING PRESSURE		MINIMUM CLEARANCES				
		Installation to Combustible Wall			Entry	
Nat	Pro	Sides	Rear	Base	Crated	Uncrated
3.5" WC	10.0" WC	6" (152mm)	6" (152mm)	8" (203mm)	45" (1143mm)	35-1/2" (902mm)

Continuous product improvement is a Garland policy.