



Item #: \_\_\_\_\_  
 Model: IR-280L Series  
 Product Name: H280 Series Infra-Red Salamander Broiler

GARLAND® GAS H280 Series Infra-Red Salamander Broiler



*Model IR36-280L*

**Specification:**

Range mount gas infra-red salamander broiler Model IR \_\_\_-280L. Available to mount over Garland Starfire H280 Series restaurant ranges 36"- 72" wide. Two (2) 20,000 BTU (5.86 kW) atmospheric infra-red burners. Three (3) position adjustable rack. Stainless steel top, front, sides, backsplash and bottom w/heat shield. 40,000 BTU (11.72 kW) total. Natural or propane gas. Certified to Canadian and US standards, listed by NSF.

**Standard Features:**

- Range Mount Models – stainless steel top, front, sides, backsplash, and bottom w/heat shield
- Counter mount IR36-280CL – stainless steel top, front, and sides – C/W 4" (102mm) legs
- 1/2" NPT top gas inlet
- Two (2) 20,000 BTU (5.86 kW) atmospheric infrared burners
- Two (2) individual Hi-Lo valve controls
- Three (3) position spring-balanced, adjustable rack assembly
- Large capacity removable grease pan
- One year limited parts & labor warranty (USA & Canada only)

**Optional Features:**

- Wall-mounting kit and stainless steel main bottom w/heat shield for model IR36-280CL
- Rear gas inlet (standard on counter model)
- Interconnecting gas piping for range-mount
- ◆ Available to fit all Garland H280 Series ranges from 36"-72" (914mm-1829mm) wide



IR-280L Series

**Garland Commercial Industries, Inc.**  
 185 East South Street  
 Freeland, Pennsylvania 18224  
 Phone: (570) 636-1000  
 Fax: (570) 636-3903

**Garland Commercial Ranges Ltd**  
 1177 Kamato Road, Mississauga, Ontario  
 L4W 1X4 CANADA  
 Phone: 905-624-0260  
 Fax: 905-624-5669

**Enodis UK LTD**  
 Swallowfield Way, Hayes, Middlesex  
 UB3 1DQ ENGLAND  
 Telephone: 081-561-0433  
 Fax: 081-848-0041



Item #: \_\_\_\_\_  
 Model: IR-280L Series  
 Product Name: H280 Series Infra-Red Salamander Broiler

Model	Width	Use With H280 Series Model	Shipping Wt. Lbs./Kgs.	Entry Clearances: In (mm)	
				Crated	Uncrated
IR36-280L	36" (914mm)	H286	200/91	29" (737mm)	21" (533mm)
IR48-280L	48" (1219mm) (36" broiler + 12"/305mm flue riser w/shelf)	H288	230/105	29" (737mm)	21" (533mm)
IR60-280L	60" (1524mm) (36" broiler + 24"/610mm flue riser w/shelf)	H284 & H287	260/118	29" (737mm)	21" (533mm)
IR72-280L	72" (1829mm) (36" broiler + 36"/914mm flue riser w/shelf)	H289	280/127	29" (737mm)	21" (533mm)

Note Salamander Broiler on Left Side. Right Side Optional

Manifold Operating Pressure		Installation Clearances		Total Input 40,000 BTU/HR (11.7Kw)
Natural	Propane	Sides	Rear	
6"WC (15mbar)	10"WC (25mbar)	6" (152mm)	6" (152mm)	

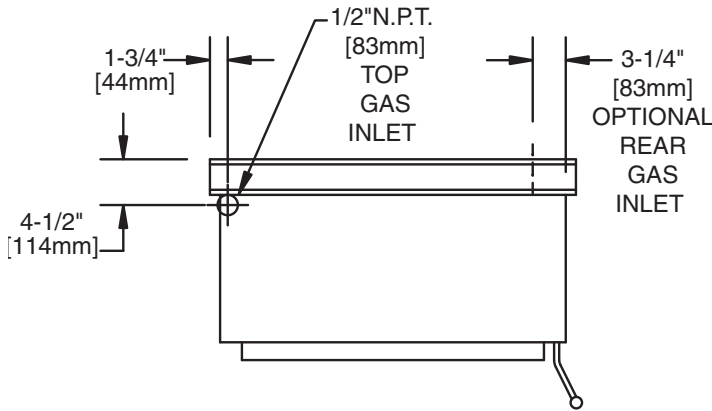

Gas input ratings shown for installations up to 2000 ft., (610m), above sea level. Please specify altitudes over 2000 ft. Please specify gas type when ordering.

Commercial cooking equipment requires an adequate ventilation system. For additional information, refer to the National Fire Protection Association's standard NFPA96.

This product is not approved for residential use.

