



Item #: _____
 Model: MSR16, MSRC
 Product Name: Master Series Infra-Red Broiler
 Salamander Broiler

GARLAND® GAS Master Series Infra-Red Salamander Broiler MSR16, MSRC



Model MSR16

Specification:

Range mount gas infra-red salamander broiler, Model #MSR16. Two (2) 14,000 BTU (4.10 kw) atmospheric burners, each with a Hi-Lo valve. Fixed position, roll-in, roll out broiling rack with flat or tilt positions. 34" (864mm) wide x 18" (457mm) deep x 35-1/2" (902mm) high backguard to top of broiler housing. 16-1/4" (413mm) high broiler housing only. 28,000 BTU (8.20kw) total. Natural or propane gas. Certified to Canadian and US standards, listed by NSF. MST prefix models carry CE Mark: for Europe.

Standard Features:

- Range Mount Model MSR16 – stainless steel front, sides, backsplash, and bottom w/heat shield
- Counter Model MSRC – stainless steel front sides, and top – C/W 4" (102mm) legs
- Fixed position broiling rack with flat or easy view tilt position, roll in, roll-out back
- Large capacity removable grease pan
- One year limited parts & labor warranty (U.S.A. & Canada Only)
- Counter Mount model -MSRC - Stainless steel front, top, and sides; and aluminized broiler housing, bottom
- 1/2" NPT top gas inlet range and wall mount models. Rear gas inlet Counter [noun] models.
- Two (2) 14,000 BTU (4.10 kw) atmospheric infra-red burners, each controlled with Hi-Lo valve. MST model prefix Sentry flame failure protection, e.g.: MSTSR16, MSTRC

Optional Features:

- Stainless steel main back.
- Stainless steel main bottom – Model MSRC
- Stainless steel main top – Model MSR16
- Brackets for wall mounting and stainless steel bottom w/heat shield – Model MSRC
- Interconnecting gas piping for range mount
- MS - Model prefix – burners with pilot shut off valve, e.g. MSSR16, MSSRC
- MST - Model prefix – Sentry flame failure protection on all burners, e.g.: MSTSR16, MSTRC.



Garland Commercial Industries, Inc.
 185 East South Street
 Freeland, Pennsylvania 18224
 Phone: (570) 636-1000
 Fax: (570) 636-3903

Garland Commercial Ranges Ltd
 1177 Kamato Road, Mississauga, Ontario
 L4W 1X4 CANADA
 Phone: 905-624-0260
 Fax: 905-624-5669

Enodis UK LTD
 Swallowfield Way, Hayes, Middlesex
 UB3 1DQ ENGLAND
 Telephone: 081-561-0433
 Fax: 081-848-0041

GARLAND®

Item #: _____

Model: MSR16, MSRC,

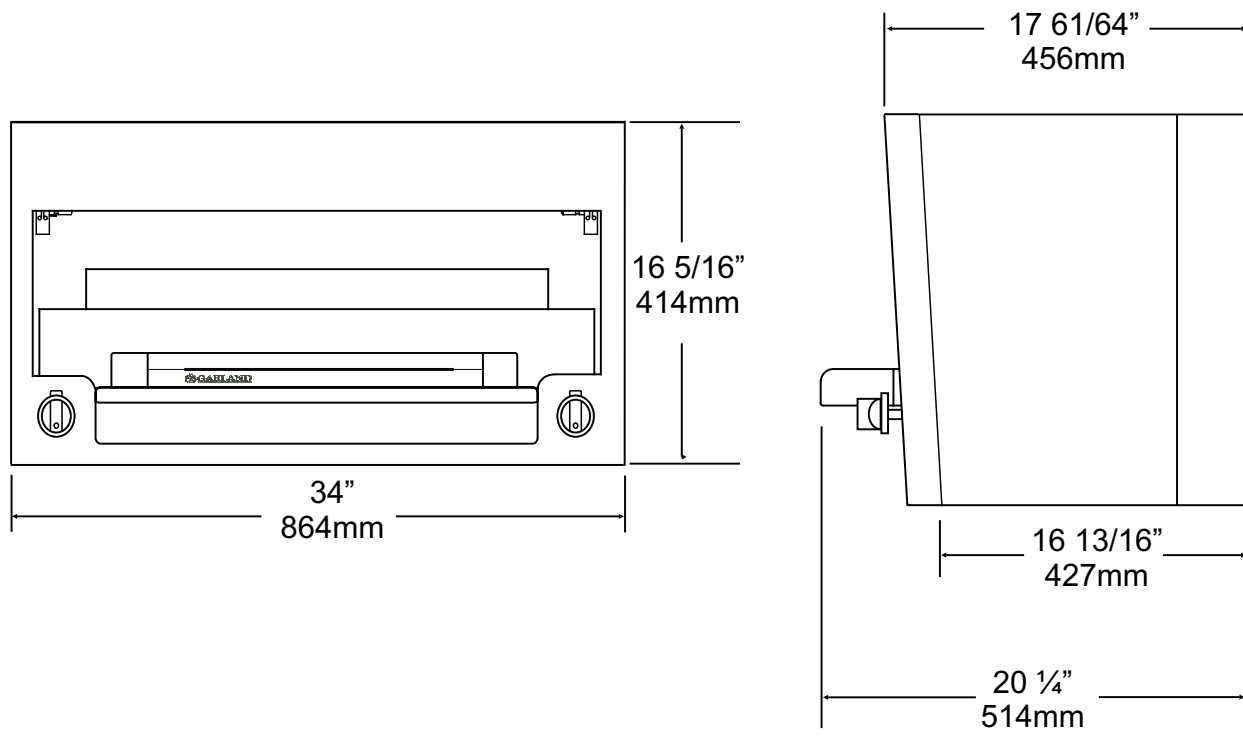
Product Name: Master Series Infra-Red Broiler
Salamander Broiler

PRODUCT	MSR16	MSC
Width: In(mm)	34(864)	34(864)
Depth: In(mm)	20-1/4(514)	20-1/4(514)
Height: In(mm)	35-5/8(965)	17(432)
INPUT:BTU/hr(kw)(Natural Gas)	28,000 (8.20)	28,000 (8.20)
Shipping Wt:(LB/KG)	170/78	135/61

INSTALLATION NOTES		
Combustible Wall Clearances ¹	Entry Clearances	Manifold Operating Pressure
Sides: 0" Back: 0"	Crated: 26-3/4" (680mm) Uncrated: 21" (533mm)	Natural: 6" WC (15mbar) Propane: 11" WC (28mbar)

¹ For installations in non-combustible locations only

NOTE: Data applies only to North America

Gas input ratings shown here are for installations up to 2,000 ft. (610m) above seal level. Specify altitudes over 2,000 ft.

Garland/U.S. Range products are not approved or authorized for home or residential use, but are intended for commercial applications only. Garland / U.S. Range will not provide service, warranty, maintenance or support of any kind other than in commercial applications

Please specify gas type when ordering.

Continuous product improvement is a Garland policy.