



Item #: _____
 Models: M100XRM, M100XSM, M100XTM
 Product Name: Master Series Infra-Red Broiler
 w/Upper Warming Oven



Model M100XRM

Specifications:

Heavy-duty gas infra-red broiler with oven and upper warming oven, Model #M100XR. Four (4) 17,500 BTU (5.14kW) direct radiant, infra-red burners. Adjustable broiler rack with removable grid. Fan-assisted clean air delivery system for broiler section. Porcelain enamel oven interior measuring 26¼" (667mm) wide x 13½" (343mm) high x 29" (737mm) deep. 40,000 BTU (11.72 kW) cast iron oven burner. Standard with stainless steel front. Two (2) independent heat controls, (left and right), for broiling chamber. Natural or propane gas. CSA certified and NSF listed. (Also available with storage base, Model #M100XSM, and modular top, Model #M100XTM).



Standard Features:

- Stainless steel front; black powder coat epoxy sides
- 6" (152mm) chrome steel adjustable legs
- 7-1/2" (191mm) stainless steel front rail
- Porcelain interior warming oven
- Four direct radiant, infra-red burners, 17,500 BTU, (5.14 kW) each
- 120 volt air intake blower motor
- Air-proving safety switch cuts off gas supply when intake blower is not operational, or if the filter is blocked.
- Removable broiler grid
- 3 position adjustable rack
- Large capacity, easily removable broiler chamber grease container located out of the heat zone
- Two (2) Hi/Med/Lo independent heat controls for broiling chamber
- Piezo spark ignition for oven
- Fully porcelainized oven interior
- 40,000 BTU (11.72 kW - natural gas)/35,000 BTU (10.25 kW - propane), cast iron oven burner
- One year limited parts & labor warranty (USA & Canada only)

Optional Features:

- Stainless steel left, right or both sides
- Stainless steel main back
- Convection oven base, add C to Model No., e.g. M100XRC
- Additional oven rack
- Rear gas connection, 1-1/4" NPT (battery installation), 3/4" NPT (stand-alone installation)
- End caps and cover (no charge) - must specify
- Swivel casters (4) w/front brakes
- Polyurethane non-marking swivel casters (4) w/front brakes
- 6" (152mm) stainless steel adjustable legs
- Toe base (not for use with "RC" oven base)
- Storage cabinet with doors
- Celsius dial for oven thermostat (no charge)

NOTE: Broilers supplied with casters must be installed with an approved restraining device.

GARLAND® GAS Master Series Infra-Red Broiler M100XRM, M100XSM, M100XTM

Garland Commercial Industries, Inc.
 185 East South Street
 Freeland, Pennsylvania 18224
 Phone: (570) 636-1000
 Fax: (570) 636-3903

Garland Commercial Ranges Ltd
 1177 Kamato Road, Mississauga, Ontario
 L4W 1X4 CANADA
 Phone: 905-624-0260
 Fax: 905-624-5669

Enodis UK LTD
 Swallowfield Way, Hayes, Middlesex
 UB3 1DQ ENGLAND
 Telephone: 081-561-0433
 Fax: 081-848-0041



Item #: _____
 Models: M100XRM, M100XSM, M100XTM
 Product Name: Master Series Infra-Red Broiler
 w/Upper Warming Oven

Product	Width: In(mm)	Depth: In(mm)	Height: In(Mm) (w/ NSF Legs)	Oven/Storage Base Interior: In(mm)		
				Width	Depth	Height
M100XRM	34(864)	38(965)	72-1/8(1831)	26-1/4(667)	29(737)	13-1/2(343)
M100XSM	34(864)	38(965)	72-1/8(1831)	26(665)	30-1/2(773)	20-1/2(519)
M100XTM	34(864)	38(965)	44-1/2(1130)	N/A	N/A	N/A

INPUT (Natural Gas)	M100XRM		M100XSM		M100XTM	
	BTU	kW	BTU	kW	BTU	kW
Top Section	70,000	20.56	70,000	20.56	70,000	20.56
Oven	40,000	11.72	N/A	N/A	N/A	N/A
TOTAL	110,00	32.28	70,000	20.56	70,000	20.56

RC=Range w/Convection Oven R=Range w/Oven S=Range w/Storage Base T=Modular Top

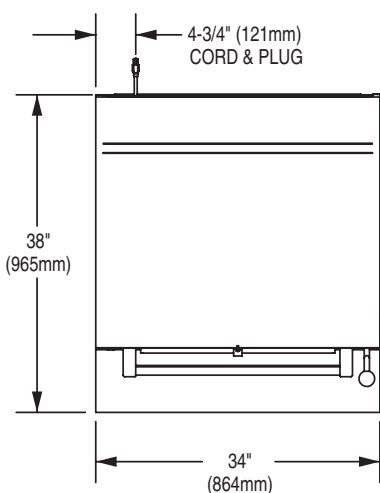

Combustible Wall Clearances ¹	Entry Clearances	Manifold Pressure
Sides: 6" (152mm) Back: 6" (152mm)	Crated: 39-1/4" (997mm) Uncrated: 34-1/4" (870mm)	Natural: 6" WC (15mbar) Propane: 11" WC (28mbar)

¹NOTE: Installation clearance reductions are applicable only where local codes permit.

Data applies only to North America

Gas input ratings shown here are for installations up to 2,000 ft. (610m) above sea level. Specify altitudes over 2,000 ft.

Commercial cooking equipment requires an adequate ventilation system. For additional information, refer to the National Fire Protection Association's standard NFPA96. (for North America only)

Electrical characteristics eaRC oven: 1/3HP motor, 120 VAC, single phase, 3.4 amps. Please specify gas type when ordering.

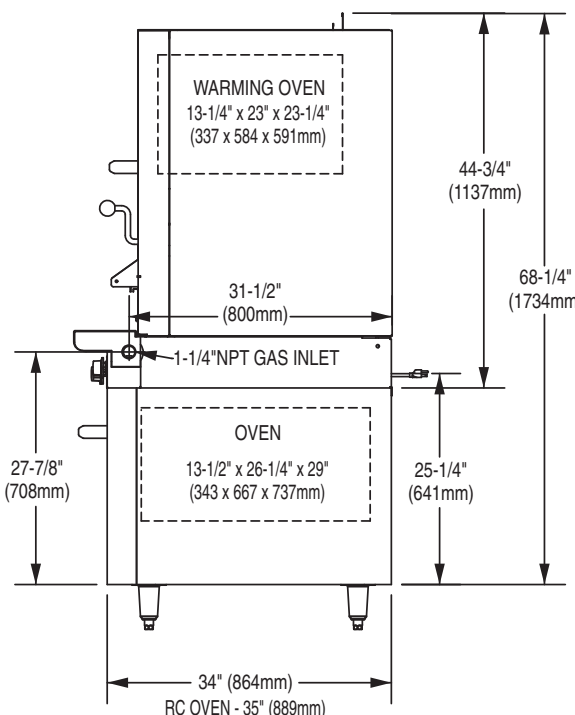
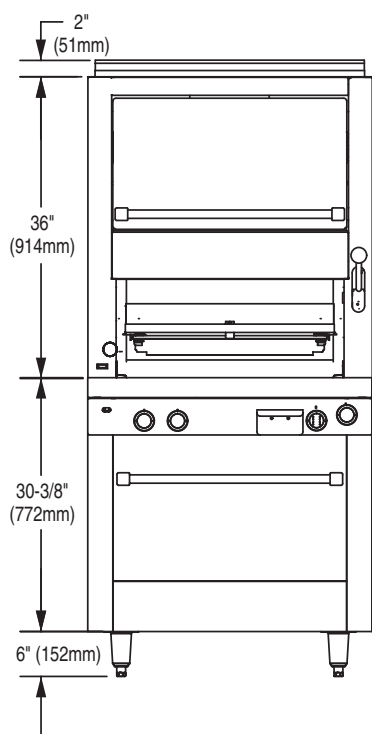

Shipping Wt: (Lb/Kg)
M100XRM: 700/318
M100XSM: 600/273
M100XTM: 510/232

Continuous product improvement is a Garland policy. Specifications and design are subject to change without notice.