



Item #: _____

Models: S686, SU686, SS686

Product Name: S686 Sentry Series 36" Medium Duty Electric Restaurant Range



Model SU686 (shown with optional casters)

Specification:

Electric medium duty range with full size, all porcelain oven interior, contoured front stainless steel plate rail, 36" (914mm) wide, with 6 all purpose tubular heating elements. Stainless steel exterior, with stainless steel 10" (254 mm) high backguard with slotted black enameled angled cap. Available with optional sealed elements with "over heat protection" – reducing power if element is turned on w/o pan for 8 minutes, hot top(s) and griddle. Available with convection oven base.



Note: Only models with prefix "SU" carry the CE Mark

NOTE: Ranges supplied with casters must be installed with an approved restraining device.

Standard Features:

- Stainless Steel exterior
- 1 large, full-size oven with complete porcelain interior finish
- Chrome plated, 4-position, removable rack guides w/1 oven rack
- Electro-mechanical heavy duty oven thermostat, (150°F/66°C - 550°F/288°C)
- 6 tubular heating elements, designed for small pot work, infinite switch controlled
- Heat resistant, cool touch oven door handle
- 10" (254mm) high stainless steel backguard with slotted black enameled angled cap
- 6" (152 mm) high stainless steel legs - Adjustable
- 1 year limited warranty on parts & labor (USA & Canada only)

CE Marked Model SU686, (& North American Model SS686)

Standard Features

- All Standard Features as above, except standard with 6 sealed, high performance elements with over heat protection and 6-heat switch

Optional Features:

- Convection oven base (add suffix - RC) Note: Convection oven comes with 3-position rack guide assembly and 3 oven racks
- Heavy duty 5/8" (16mm) thick thermostatically controlled griddle plate available in the following widths:
 - 12"(305mm): Add suffix 12GR (right side) or 12GL (left side)
 - 24"(610mm): Add suffix 24GR (right side) or 24GL (left side)
 - 36"(915mm): Add suffix 36G
- Solid Steel Plates 1/2"(13mm) thick – ideal for warming and holding product – utilizing front and rear switch controls, available in the following widths:
 - 12"(305mm): Add suffix 1L (left side) or 1R (right side)
 - 24"(610mm): Add suffix 2L (left side) or 2R (right side)
 Note: Hot tops are standard on the left, optional on right side
- Sealed high performance elements with over heat protection and 6-heat switch.

Note: Sealed elements are not available with all-purpose tabular elements. All top elements must be the same type.
- Additional Oven Rack
- Swivel casters with front brakes
- 17"(432mm) high stainless steel backguard with slotted black enameled angled cap
- Stainless steel two piece easy to assemble backguard and plate shelf
- Range mounted salamander broiler (Model SER-680). CE Marked range mounted salamander is SUER-680.
- Marine equipment - storm rails for pots, oven door latch, drip tray stop and deck fasteners

GARLAND® ELECTRIC S680 Sentry Series 36" Electric Range Models: S686, SU686, SS686

Garland Commercial Industries, Inc.
 185 East South Street
 Freeland, Pennsylvania 18224
 Phone: (570) 636-1000
 Fax: (570) 636-3903

Garland Commercial Ranges Ltd
 1177 Kamato Road, Mississauga, Ontario
 L4W 1X4 CANADA
 Phone: 905-624-0260
 Fax: 905-624-5669

Enodis UK LTD
 Swallowfield Way, Hayes, Middlesex
 UB3 1DQ ENGLAND
 Telephone: 081-561-0433
 Fax: 081-848-0041



Item #: _____
 Models: S686, SU686, SS686
 Product Name: S686 Sentry Series 36" Medium Duty Electric Restaurant Range

Model	Total Kw Load	Nominal Amps					
		208V/1Ph	208V/3 Ph	240V/1Ph	240V/3 Ph	400 V/3N	415V/3N
S686*	15	72	48	62	42	—	—
S686RC	16	75	51	64	44	—	—
SS/SU686**	19	90	59	78	52	40	38
SS/SU686RC	20	93	62	80	54	40	38
Salamander Broiler***	7	34	19	29	16	4	4

*All purpose tubular elements; **Sealed -top elements, Model # SS686 in North America; ***Add when wired to range base (SER/SUER-680)

Exterior Dimensions			Oven Interior Dimensions		
Height	Width	Depth†	Height	Width	Depth
47" (1194mm)	36" (914mm)	34-1/4" (870mm)	13-1/2" (343mm)	26-1/4" (667mm)	22" (559mm)

† With front rail

Entry Clearances		
Crated	Uncrated	Uncrated "RC" Model
45" (1143mm)	35" (889mm)	40" (1016mm)

Installation Clearances:	Side	Back
Range w/o Salamander	3" (76mm)	2" (51mm)
Range w/ Salamander	7" (178mm)	2" (51mm)
Warming/Holding Steel Plates	10" (254mm)	—

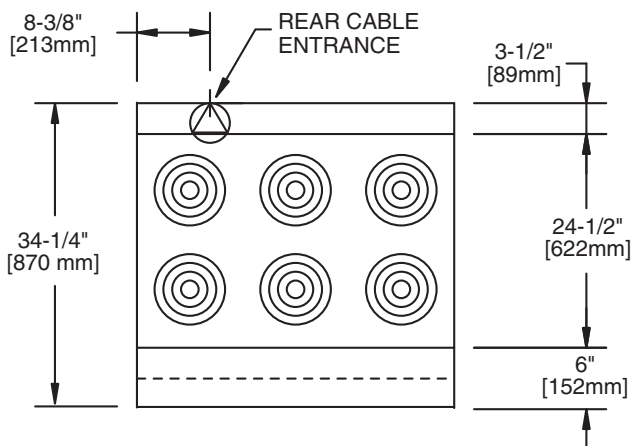

Ratings:

Tubular Elements: 6-1/2" (165mm): 1250 Watts
 8-1/2" (216mm): 2100 Watts
 Sealed High Performance Elements: 7" (180mm): 2000 Watts
 8-5/8" (220mm): 2600 Watts

Warming/Holding Steel Plate: (per 12"/305mm section):
 Front and Rear sections each 1675 Watts,
 (3350 Watts total)

Griddle (per 12"/305mm section): 3350 Watts

Standard Oven: 4.85 kW

Convection Oven: 5.0 kW (+0.5kW fan motor; for 5.5kW total)

NOTE: For ranges with convection oven, (models with suffix 'RC'), air circulation is required for proper operation of fan motors. These models must not be dais mounted or installed without legs.

NOTE: Many local codes exist, and it is the responsibility of the Owner and the Installer to comply with those codes.

