



Item #: \_\_\_\_\_

Models: S18F, S18SF

Product Name: S680 Sentry Series  
Electric Restaurant Fryer



Model S18F

**Specification:**

Electric medium duty fryer with 30 lb. (14kg) shortening capacity. Stainless steel exterior construction with styling designed to match Garland S680 Series Electric Restaurant Ranges. 18" (457mm) wide, 34½" (877mm) deep. Unit to be either a model S18F, (12 kW), or model S18SF (16 kW). Fry tank is a one piece, deep drawn, heavy gauge nickel-plated steel tank equipped with lift handles to remove the container for easy cleaning. 1" (25mm) drain valve located at bottom of tank. Incoloy sheath heating elements swing up and out of the way for easy removal of fry tank. Cabinet designed with slides to accept an optional additional fry tank.

**Standard Features:**

- Stainless steel finish front and sides
- Designed to match Garland S680 Sentry Series Electric Ranges
- Available in 12kW (S18F) and 16kW (S18SF)
- 30 lb (14kg) shortening capacity tank is a one piece, deep drawn, heavy gauge nickel plated steel tank equipped with lift handles to remove tank with 1" (25mm) drain valve at bottom.
- Two chrome wire baskets
- Mechanical thermostat temperature control from 200°F (93°C) - 375°F (190°C)
- Incoloy sheath hearing elements swing up & out of the way for easy cleaning & fry tank removal
- Cabinet has slides to accept optional additional fry tank
- 6" (152mm) chrome steel adjustable legs

**Optional Features:**

- Matching end unit with or without heat lamp, cut out for 2" x 20" pan or solid top, cabinet base
- Lift-off, single drain shelf
- Additional tank with drain
- Extra set of twin baskets
- Large single basket
- Stainless steel fryer bowl cover
- Swivel casters with front brakes
- Fish plate

NOTE: Fryers supplied with casters must be installed with an approved restraining device.



Garland Commercial Industries, Inc.  
185 East South Street  
Freeland, Pennsylvania 18224  
Phone: (570) 636-1000  
Fax: (570) 636-3903

Garland Commercial Ranges Ltd  
1177 Kamato Road, Mississauga, Ontario  
L4W 1X4 CANADA  
Phone: 905-624-0260  
Fax: 905-624-5669

Enodis UK LTD  
Swallowfield Way, Hayes, Middlesex  
UB3 1DQ ENGLAND  
Telephone: 081-561-0433  
Fax: 081-848-0041

GARLAND® ELECTRIC S680 Sentry Series Restaurant Fryer Models: S18F, S18SF



Item #: \_\_\_\_\_  
 Models: S18F, S18SF  
 Product Name: S680 Sentry Series  
 Electric Restaurant Fryer

North American (60 cycle) Electrical Loading:												
Model	Total kW	Nominal Amperes Per Line										
		208v/1Ø	240V/1Ø	208V/3Ø			240V/3Ø			480V/3Ø		
				X	Y	Z	X	Y	Z	X	Y	Z
S18F	12	58	50	34	34	34	29	29	29	15	15	15
S18SF	16	77	67	49	38	49	42	33	42	21	17	21

Export (50 cycle) Electrical Loading:										
Model	Total kW		Nominal Amperes Per Line							
			220/380V/ 1Ø	240/415V/ 1Ø	220/380/3Ø			240/415V/3Ø		
	220/380V	240/415V			X	Y	Z	X	Y	Z
S18F	10.1	12	46	50	16	16	16	17	17	17
S18SF	13.4	16	61	67	27	18	18	30	19	19

**DAIS Installation:**

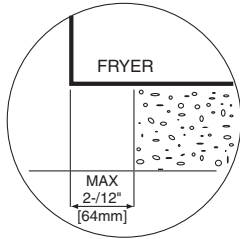

Frying area is 13" (330mm) wide x 15-1/2" (394mm) deep.

**Installation Clearances:**

Clearance to combustible surfaces  
 Sides: 1" (25mm) Rear: 1-1/2" (38mm)

**NOTE:** Many local codes exist, and it is the responsibility of the Owner and the Installer to comply with those codes.

Production Capacity (per hour)	
Model	French Fries
S18F	Frozen to Done 50 lbs. /23kg
S18SF	Frozen to Done 60 lbs./ 27kg

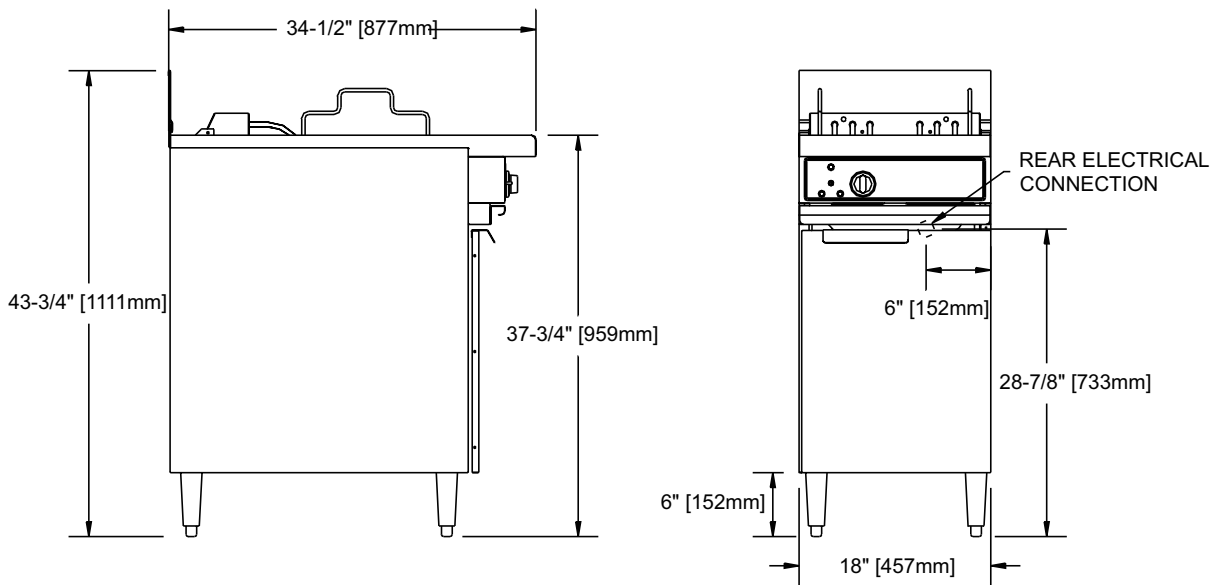

Frying area is 13" (330mm) wide x 15 1/2" (394mm) deep