

*Model EFW500***Specification:**

The EFW500 is a lightweight, durable, wet-use-only Counter Food Warmer. The unit comes standard with a NEMA 5-15P cord and plug, which enables use in any location where there is an appropriate 120V electrical outlet. The 500 Watt warmer, with preset thermostat maintains a water bath temperature of 180°F - 200°F. The tank accepts 1/3-size pans up to 4" deep. Overheat protection is provided by a built-in safety high-limit thermostat. Operation is controlled by a single illuminated On/Off power switch.

Standard Features:

- Illuminated On/Off power switch
- Built-in, preset thermostat with high-limit control
- Stainless steel tank and exterior front and sides
- Power cord with NEMA 5-15P plug
- Pan capacity: one-third-size food pans up to 4" deep
- Limited 1-year factory warranty, (please call 800.427.6668 for warranty service instructions and details)



Garland Commercial Industries, Inc.
185 East South Street
Freeland, Pennsylvania 18224
Phone: (570) 636-1000
Fax: (570) 636-3903

Garland Commercial Ranges Ltd
1177 Kamato Road, Mississauga, Ontario
L4W 1X4 CANADA
Phone: 905-624-0260
Fax: 905-624-5669

Enodis UK LTD
Swallowfield Way, Hayes, Middlesex
UB3 1DQ ENGLAND
Telephone: 020-8561-0433
Fax: 020-8848-0041

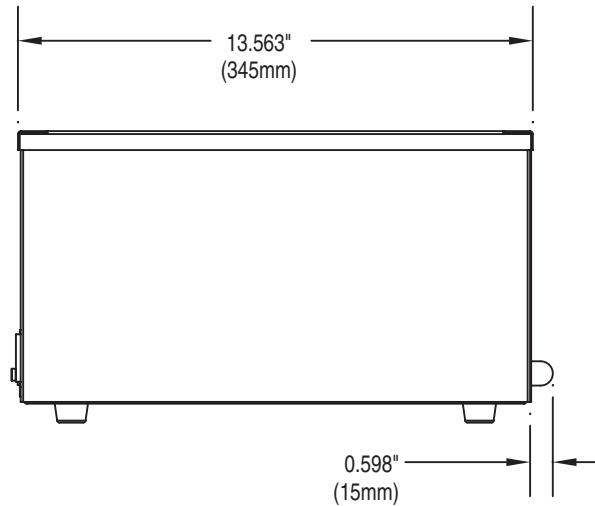
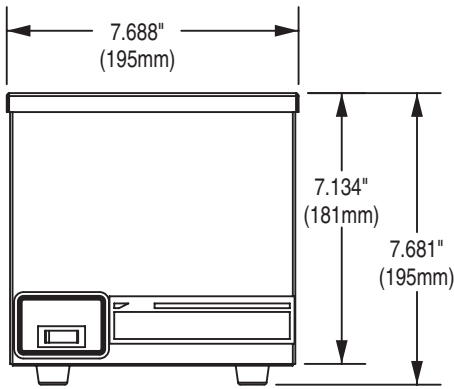
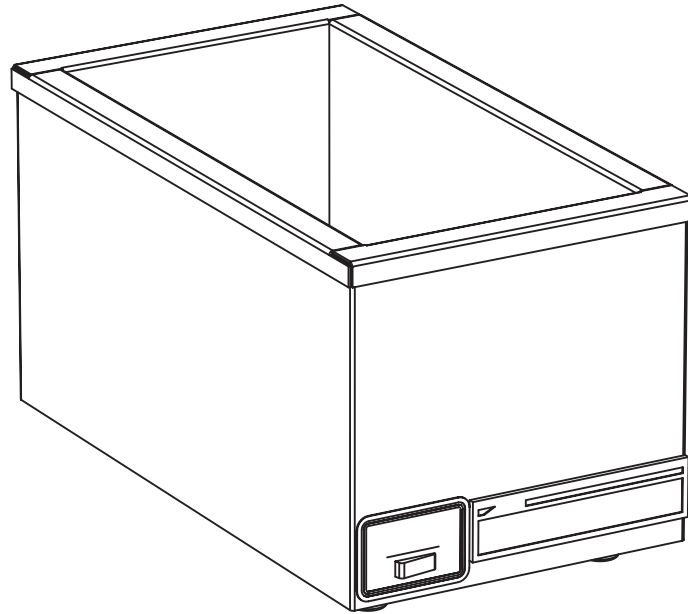
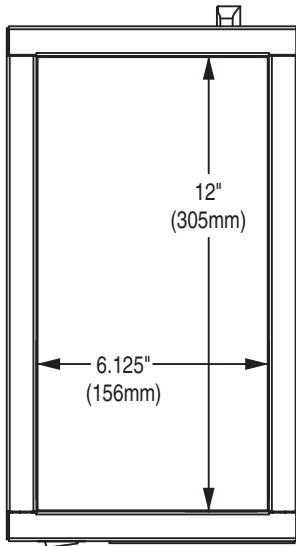

Voltage	Phase	kW	Nominal Amperes	Connection Type
120	1	0.5	4.17	5' cord w/NEMA 5-15P plug

Clearances				Shipping Weight
Installation		Entry		
Sides	Rear	Crated	Uncrated	
0"	0"	9-1/2" (241mm)	7-5/8" (195mm)	13lbs. (5.5kg)