



Model ED-15W

Specification:

Electric designer series easy to use warmers (wet use only) model ED-15W or 120Volt unit with plug and cord model ED-15-WP. Designed as free standing or to be banked with other ED series equipment. Each model 15"(381mm) wide x 24" (610mm) deep x 11 1/2" (292mm) high, easy clean design with stainless steel front and black painted sides, and stainless steel 6-3/8" (162mm) deep removable well ensuring quick draining and easy cleaning. Accepts series 200 12" (305mm) x 20" (508mm) or Gastronorm 1/1 cafeteria pans. An infinite switch with pilot light regulates heat.

Standard Features:

- Stainless steel front and black painted sides
- Easy clean design with recessed protected controls
- Stainless steel 6-3/8" (162mm) deep removable well for easy cleaning and draining
- Infinite switch controlled
- Heat-On indicator lamps
- One-Year limited parts & labor warranty (USA & Canada only)

Optional Features:

- Stainless steel body side
- Stainless steel back and bottom
- "CE" approval for model ED-15W, add prefix U, i.e. Model EDU-15W, "CE" approval not available for ED-15WP

Optional CSD Series Stands:

- Floor Stands: Heavy-duty stands of open design with seamless welded square tube leg and black finish storage shelf. Working height of all units on stands 35-1/2" (902mm). Stand widths available in 15" (381mm). Each unit must have its own stand. Example for ED-15W Warmer, specify compatible CSD-15 stand.
 - Optional: Stainless steel finish
 - Swivel casters W/front brakes; set of 4



Garland Commercial Industries, Inc.
 185 East South Street
 Freeland, Pennsylvania 18224
 Phone: (570) 636-1000
 Fax: (570) 636-3903

Garland Commercial Ranges Ltd
 1177 Kamato Road, Mississauga, Ontario
 L4W 1X4 CANADA
 Phone: 905-624-0260
 Fax: 905-624-5669

Enodis UK LTD
 Swallowfield Way, Hayes, Middlesex
 UB3 1DQ ENGLAND
 Telephone: 081-561-0433
 Fax: 081-848-0041

Models	Total kW Load				Nominal Amperes Per Line							
	North America		Export		North America				Export			
	208V	240V	220V/ 380V	240V/ 415V	Single Phase		Hi Line -3 Phase		Single Phase		Hi Line - 2 or -3 Phase	
	208V	240V	220V/ 380V	240V/ 415V	208V	240V	208V	240V	220V/ 380V	240V/ 415V	220V/ 380V	240V/ 415V
ED-15W, EDU-15W	1.0	1.0	1.12	1.0	5	5	N/A	N/A	6	5	N/A	N/A
ED-15WP	A 120V Unit. 1.0 kW, 8.3 Amps											

Model	Overall Dimensions			Shipping Wt. Lb/kg
	Height	Width	Depth	
ED-15W	11-1/2" (292mm)	15" (381mm)	24" (610mm)	50/23
ED-15WP	11-1/2" (292mm)	15" (381mm)	24" (610mm)	50/23

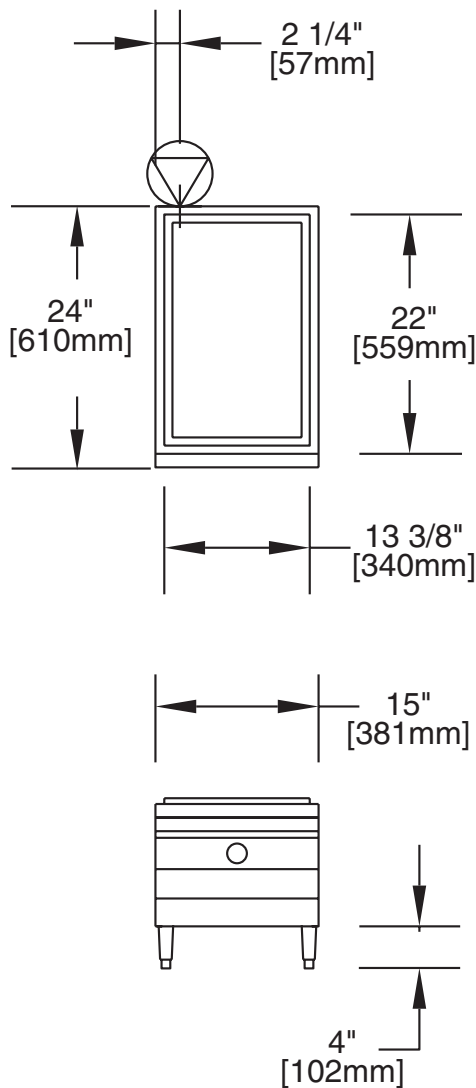

Garland products are not approved or authorized for home or residential use, but are intended for commercial applications only. Garland will not provide service, warranty, maintenance or support of any kind other than in commercial applications.

NOTE: ED Series food warmers are wet type only. Operating these units dry for extended periods may cause the tank assembly to warp and void the warranty.

Installation Clearances	
Side	Rear
1" (25mm)	1" (25mm)

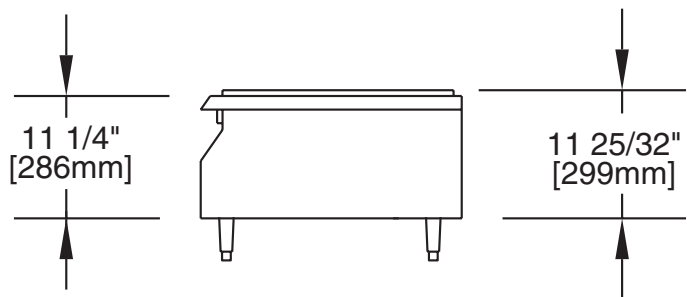

Continuous product improvement is a Garland policy. Specifications and design are subject to change without notice.