



*Model ED15THSE*

### Specification:

Dependable 7-1/2" (192 mm) diameter sealed solid element hot plate and recessed top ensure quicker clean-ups. Each plate element is controlled by a switch with six heat positions. Elements are protected with a high limit which automatically reduces power to prevent over heating.

### Standard Features:

- Stainless steel front & black painted sides
- Two 7-1/2" (192 mm) diameter sealed elements
- Each element rated 2000 watts
- Each element controlled by a switch with six heat positions that automatically cycles down to a low heat when left unused
- Heat-On indicating lamps
- 4" (102mm) stainless steel legs
- One-year limited parts & labor warranty (USA & Canada only)

### Optional Features:

- Stainless steel body side
- Stainless steel back and bottom

### Optional CSD Series Stands:

- Floor Stands: Heavy-duty stands of open design with seamless welded square tube leg and black finish storage shelf. Working height of all units on stands 35-1/2" (902mm). Available in 15" (381mm) width. Each unit must have its own stand. Example for ED15HSE hotplate, specify compatible CSD-15 stand.
  - Optional: Stainless steel finish
  - Swivel casters W/front brakes; set of 4



**Garland Commercial Industries, Inc.**  
 185 East South Street  
 Freeland, Pennsylvania 18224  
 Phone: (570) 636-1000  
 Fax: (570) 636-3903

**Garland Commercial Ranges Ltd**  
 1177 Kamato Road, Mississauga, Ontario  
 L4W 1X4 CANADA  
 Phone: 905-624-0260  
 Fax: 905-624-5669

**Enodis UK LTD**  
 Swallowfield Way, Hayes, Middlesex  
 UB3 1DQ ENGLAND  
 Telephone: 020-8561-0433  
 Fax: 020-8848-0041



Item #: \_\_\_\_\_

Model: ED15THSE

Product Name: Electric Designer Series Hot Plate

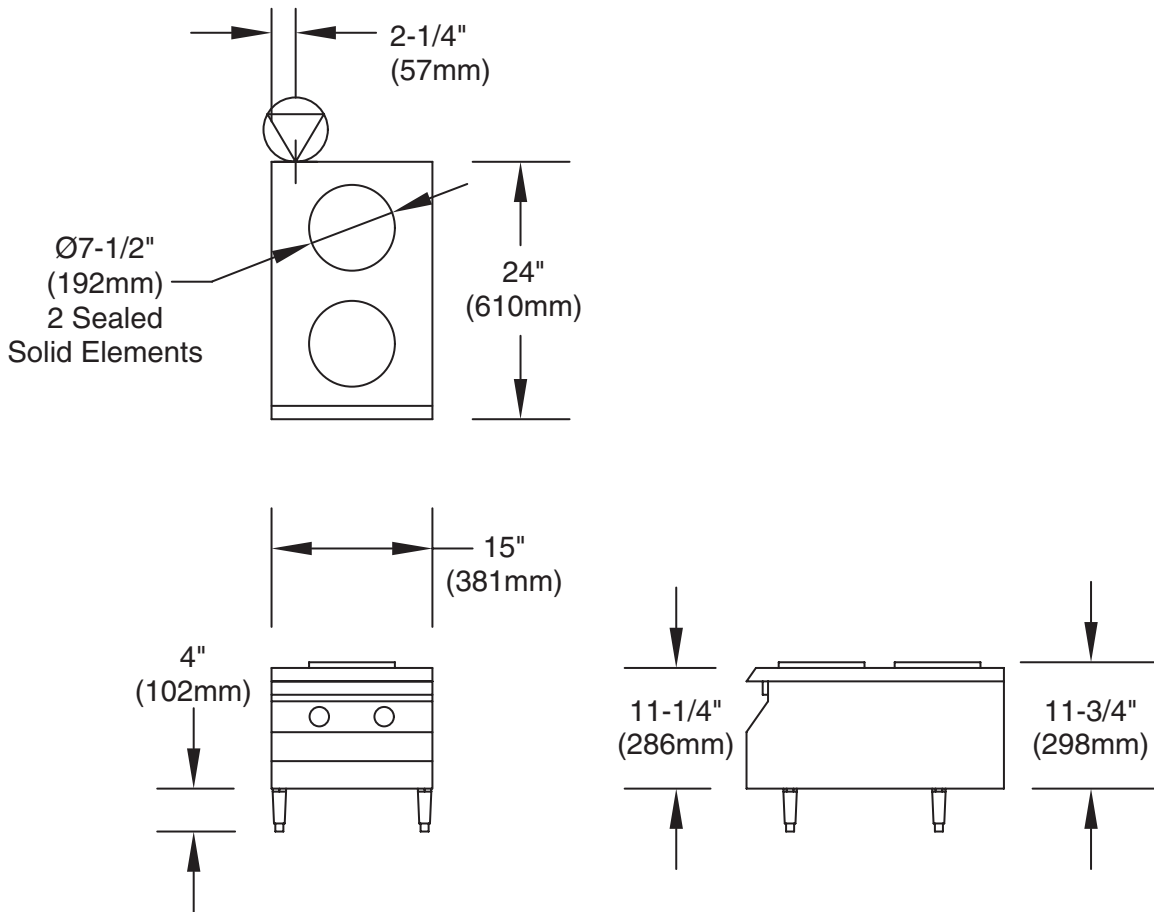

Total kW Load		kW Load Per Phase						Nominal Amperes Per Line								
								Sgl. Phase		3-Phase						
208V	240V	208V			240V			208	240	208			240			
		X-Y	Y-Z	X-Z	X-Y	Y-Z	X-Z			X	Y	Z	X	Y	Z	
4.0	4.0		2.0	2.0		2.0	2.0	19.2	16.7	9.5	9.5	16.7	8.3	8.3	14.4	

FOR VOLTAGE OPTIONS OUTSIDE NORTH AMERICA, PLEASE CONTACT THE FACTORY

Overall Dimensions			Clearances				Shipping Weight
			Installation		Entry		
H	W	D	Sides	Rear	Crated	Uncrated	
11-1/4" (286mm)	15" (381mm)	24" (610mm)	1-1/2" (38mm)	1-1/2" (38mm)	18-1/2" (470mm)	15" (381mm)	50lbs. (23kg)

Continuous product improvement is a Garland policy.