



*Model ED-15H*

### Specification:

Electric designer series hot plates are available in two different model configurations. Model ED-15H with two high speed 8" (203mm) diameter elements, providing quick even heat offering cooking versatility, with easily removed porcelain enameled bowls to catch spill overs and Model ED-15HE with two 8" (203mm) sealed solid elements, with an energy saving feature that automatically cycles down when not in use. Each hot plate element is controlled with a six position switch. Both models have a recessed top to contain spillage and ensure quicker cleanups. Designed as stand alone or to be banked with other ED series equipment. 15" (381mm) wide, x 24" (610mm) deep x 11.25" (286mm) high, with easy clean design stainless steel front and black painted sides and 4" (102mm) stainless steel legs.

### Standard Features:

- Stainless steel front and black painted sides
- 4" (102mm) Sanitary legs
- Easy clean design with recessed protected controls.
- Heat-On indicator lamps
- Two models one with two 8" (203mm) coil elements (ED-15H) and one with 8" (203mm) sealed solid elements (ED-15HSE)
- One-Year limited parts & labor warranty (USA & Canada only)

### Optional Features:

- Stainless steel body side
- Stainless steel back and bottom
- "CE" approval only available on the EDU-15HSE model which has two 8" (203mm) sealed solid elements.

### Optional CSD Series Stands:

- Floor Stands: Heavy-duty stands of open design with seamless welded square tube leg and black finish storage shelf. Working height of all units on stands 35-1/2" (902mm). Available in 15" (381mm) width. Each unit must have its own stand. Example for ED-15H hotplate, specify compatible CSD-15 stand.
  - Optional: Stainless steel finish
  - Swivel casters W/front brakes; set of 4



**Garland Commercial Industries, Inc.**  
 185 East South Street  
 Freeland, Pennsylvania 18224  
 Phone: (570) 636-1000  
 Fax: (570) 636-3903

**Garland Commercial Ranges Ltd**  
 1177 Kamato Road, Mississauga, Ontario  
 L4W 1X4 CANADA  
 Phone: 905-624-0260  
 Fax: 905-624-5669

**Enodis UK LTD**  
 Swallowfield Way, Hayes, Middlesex  
 UB3 1DQ ENGLAND  
 Telephone: 081-561-0433  
 Fax: 081-848-0041



Item #: \_\_\_\_\_

Model: ED-15H & ED-15HSE

Product Name: Electric Designer Series Hot Plates

Models	Total kW Load				Nominal Amperes Per Line							
					North America				Export			
	North America		Export		Single Phase		Hi Line -3 Phase		Single Phase		Hi Line - 2 or -3 Phase	
208V	240V	220V/380V	240V/415V	208V	240V	208V	240V	220V/380V	240V/415V	220V/380V	240V/415V	
ED-15H	4.2	4.2	4.2	4.2	21	18	18	16	20	18	10	9
ED-15HSE, EDU-15HSE	5.2	5.2	5.2	5.2	25	22	22	19	24	22	12	11

Model	Overall Dimensions			Shipping Wt. Lb/kg
	Height	Width	Depth	
ED-15H	11-1/4" (286mm)	15" (381mm)	24" (610mm)	46/21
ED-15HSE	11-1/4" (286mm)	15" (381mm)	24" (610mm)	50/23

Garland products are not approved or authorized for home or residential use, but are intended for commercial applications only. Garland will not provide service, warranty, maintenance or support of any kind other than in commercial applications.

Installation Clearances	
Side	Rear
1.5" (38mm)	1.5" (38mm)

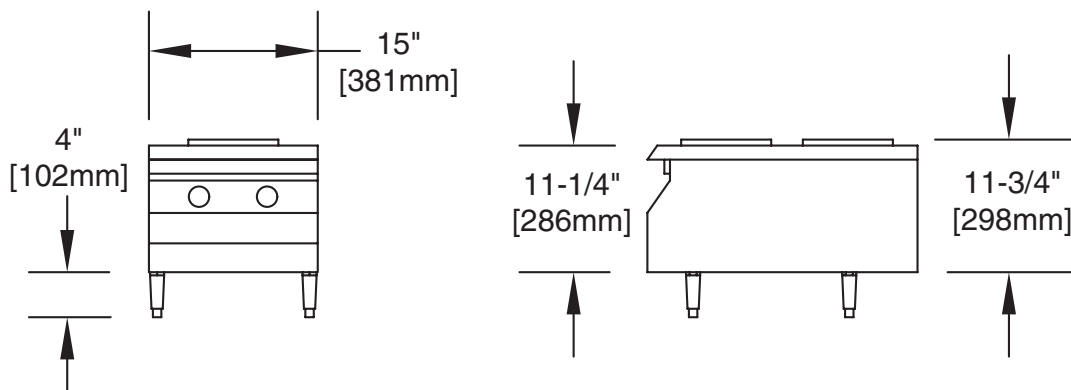
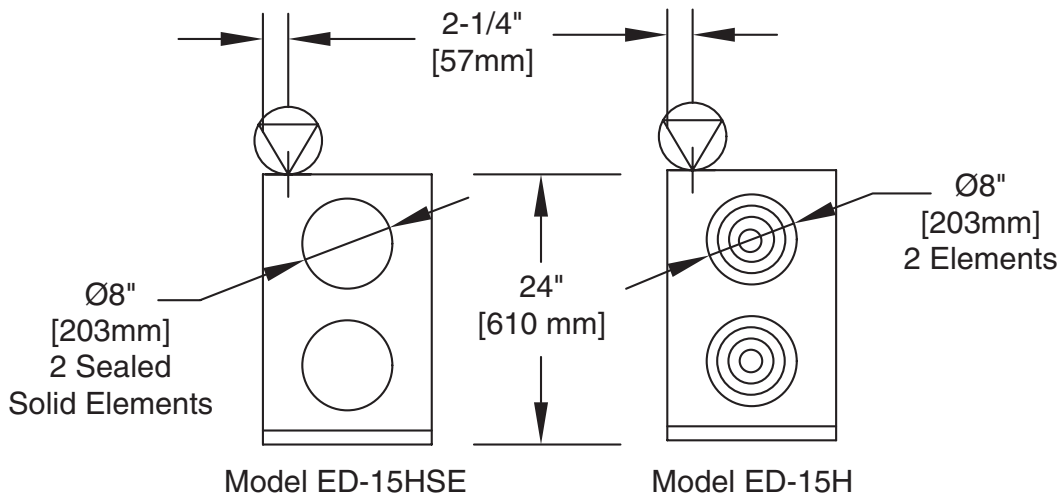

Continuous product improvement is a Garland policy. Specifications and design are subject to change without notice.