



*Model ED-30B*

### Specification:

Electric designer series broilers in three widths: models ED-15B, 15" (381mm) wide; ED-30B, 30" (706mm) wide and ED-42B, 42" (1067mm) wide. Each 12" (305mm) section controlled by an infinite switch. Designed as free standing or to be banked with other ED series equipment. 24" (610mm) deep x 13- 3/4" (349mm) high, easy clean design with stainless steel front and black painted sides, concealed grease drawer behind lower hinged panel, grate lift handle and optional broiler splatter shield. Ribs in grate give distinct brand.

### Standard Features:

- Stainless steel front and painted sides
- Easy clean design with recessed protected controls and ample space between elements and side splash walls
- Grate lift handle
- Concealed grease drawer
- Heat-On indicator lamps
- Infinite switch controlled; one per foot of width
- One-Year limited parts & labor warranty (USA & Canada only)

### Optional Features:

- Stainless steel body side
- Stainless steel back and bottom
- Broiler splatterguard, 15" (381mm), 30" (705mm) and 42" (1067mm) wide.
- 24" (610mm) wide nickel plated shelf to fit 30" (705mm) splatterguard or 36" (914mm) shelf to fit 42" (1067mm) splatter guard, please specify.
- "CE" approval add prefix U, i.e. Model EDU-15B

### Optional CSD Series Stands:

- Floor Stands: Heavy-duty stands of open design with seamless welded square tube leg and black finish storage shelf. Working height of all units on stands 35-1/2" (902mm). Stand widths available in 15" (381mm), and 30" (706mm) and 42" (1067mm). Each unit must have its own stand. Example for ED-30B Griddle, specify compatible CSD-30 stand.
  - Optional: Stainless steel finish
  - Swivel casters W/front brakes; set of 4



**Garland Commercial Industries, Inc.**  
 185 East South Street  
 Freeland, Pennsylvania 18224  
 Phone: (570) 636-1000  
 Fax: (570) 636-3903

**Garland Commercial Ranges Ltd**  
 1177 Kamato Road, Mississauga, Ontario  
 L4W 1X4 CANADA  
 Phone: 905-624-0260  
 Fax: 905-624-5669

**Enodis UK LTD**  
 Swallowfield Way, Hayes, Middlesex  
 UB3 1DQ ENGLAND  
 Telephone: 081-561-0433  
 Fax: 081-848-0041



Item #: \_\_\_\_\_

Model: ED-15B, ED-30B & ED-42B

Product Name: Electric Designer Series Broilers

Models: ED-15B, ED-30B & ED-42B

Designer Series Broilers

GARLAND® ELECTRIC

Models	Total kW Load				Nominal Amperes Per Line							
					North America				Export			
	North America		Export		Single Phase		Hi Line -3 Phase		Single Phase		Hi Line - 2 or -3 Phase	
	208V	240V	220V/380V	240V/415V	208V	240V	208V	240V	220V/380V	240V/415V	220V/380V	240V/415V
ED-15B, EDU-15B	2.7	2.7	2.7	2.7	13	12	N/A	N/A	13	12	N/A	N/A
ED-30B, EDU-30B	5.4	5.4	5.4	5.4	26	23	23	20	25	23	13	12
ED-42B, EDU-42B	8.1	8.1	8.1	8.1	39	34	23	20	37	34	13	12

Model	Overall Dimensions			Usable Cooking Surface		Shipping Wt. Lb/kg
	Height	Width	Depth	Width	Depth	
ED-15B	13-3/4" (349mm)	15" (381mm)	24" (610mm)	11-1/2" (292mm)	19" (483mm)	70/41
ED-30B	13-3/4" (349mm)	30" (762mm)	24" (610mm)	23" (584mm)	19" (483mm)	100/45
ED-42B	13-3/4" (349mm)	42" (1067mm)	24" (610mm)	34-1/2" (876mm)	19" (483mm)	145/66

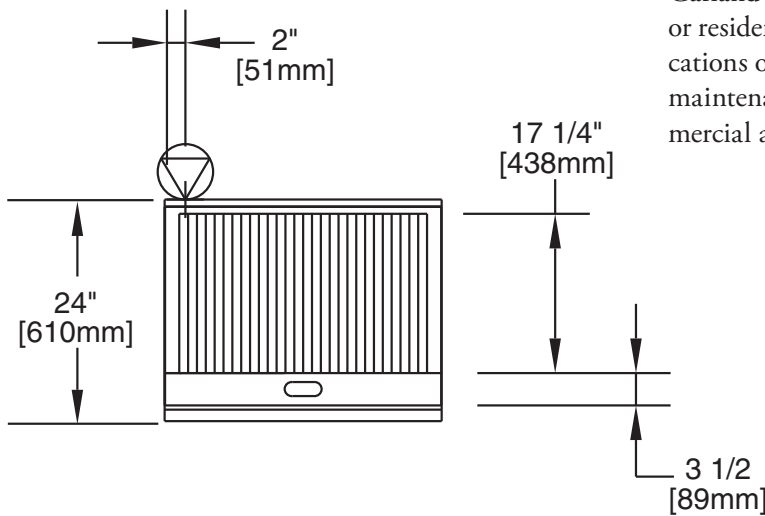

Garland products are not approved or authorized for home or residential use, but are intended for commercial applications only. Garland will not provide service, warranty, maintenance or support of any kind other than in commercial applications.

Installation Clearances	
Side	Rear
9" (229mm)	9" (229mm)

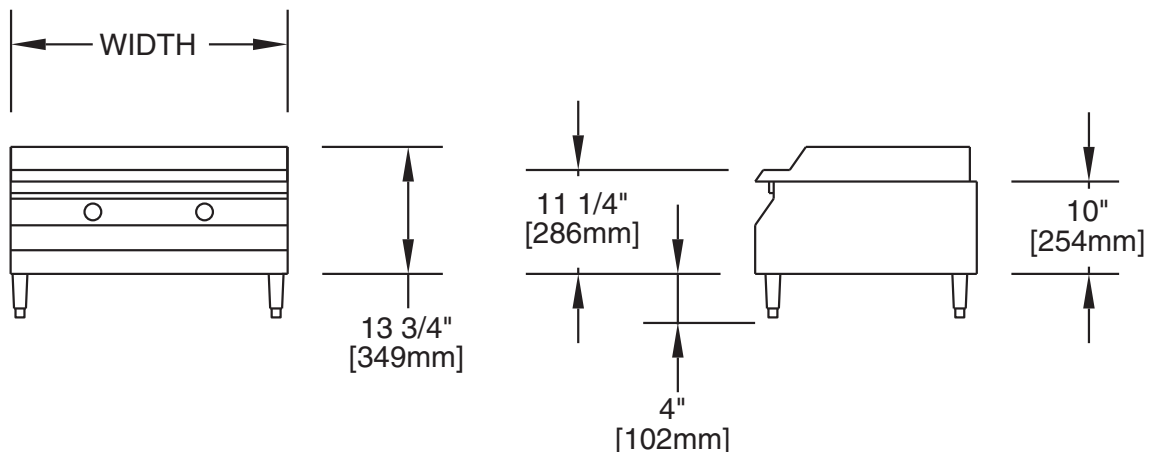

Continuous product improvement is a Garland policy. Specifications and design are subject to change without notice.

Printed in USA

Form # ED-15B, ED-30B& ED-42B (08/06)