

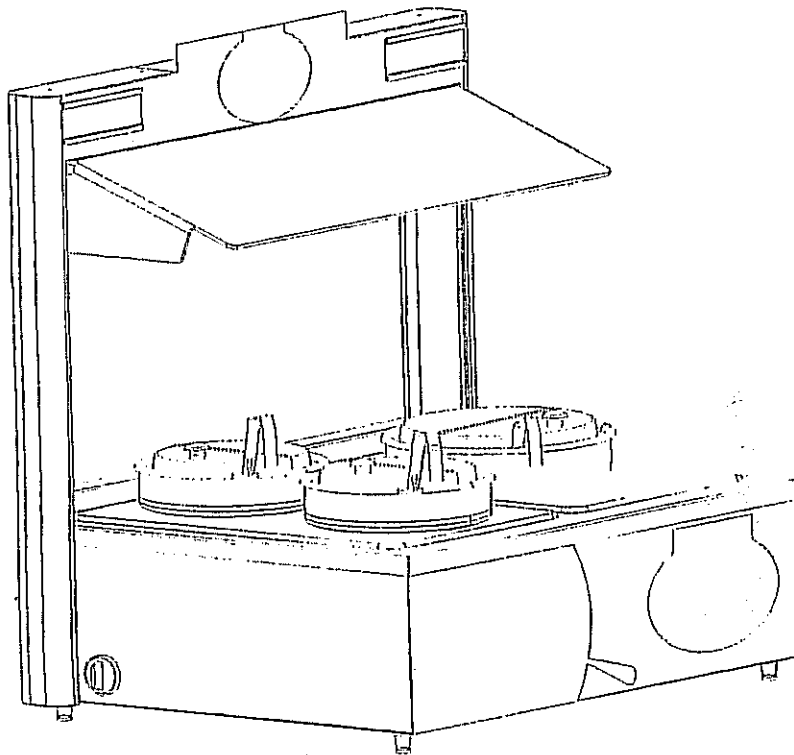

# Campbell's<sup>®</sup> Tabletop Merchandisers

Operators Manual

Models TTM2-7777, TTM2-1111, TTM2-7711, TTM2-77 and TTM2-711



For information or technical assistance, call:

**TOLL FREE**

1(800) 735-DUKE (3853)

or

1(314) 231-1130

219426 REV. A



## TABLE OF CONTENTS

MANUFACTURER'S INTRODUCTION .....	2
GENERAL SPECIFICATIONS .....	2
INSTALLATION REQUIREMENTS .....	2
SPECIFICATION SHEET .....	3
INSTALLATION INSTRUCTIONS .....	4
PERIODIC MAINTENANCE, CHECKLIST AND CLEANING GUIDE .....	5
TROUBLESHOOTING .....	10
PARTS LISTS AND ILLUSTRATIONS .....	12
WIRING SCHEMATIC .....	17
LIMITED WARRANTY .....	18

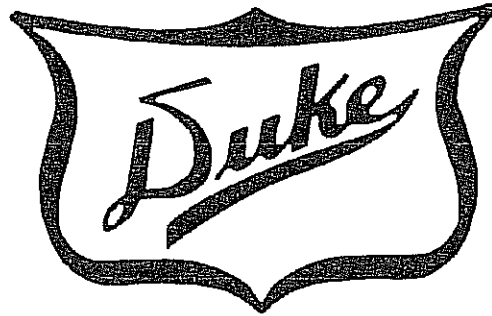



# CAMPBELL'S® TABLETOP MERCHANDISER BY DUKE

## RESTAURANT EQUIPMENT MANUAL

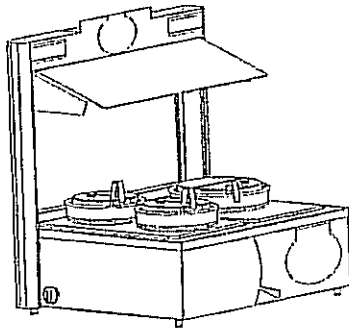

### Manufacturer's Introduction

The Campbell's® Tabletop Merchandiser is designed to create a destination soup station driving soup sales and profits. This attractive, sturdy and efficient equipment bears the Campbell's® brand and is manufactured by Duke Manufacturing Company to Campbell's® exacting standards. These units are easily adaptable to meet your merchandising needs. Designed for simple set up and trouble free maintenance, they put the Campbell's® brand right up front.

The Campbell's® Tabletop Merchandiser is ideal for cafeteria lines, convenience stores, delis, colleges and universities, schools and more. The tantalizing photographic display tempts with the promise of satisfying soup backed by Campbell's® quality reputation. The space efficient design fits virtually anywhere and will accommodate 7-Quart or 11-Quart soup inserts in varying configurations.

Supplier Name: Duke Manufacturing Co.  
Address: P.O Box 503574  
St. Louis, MO 63150-3574  
Model #: TTM2-1111, TTM2-7777,  
TTM2-7711, TTM2-711,  
TTM2-77  
Serial #: \_\_\_\_\_  
Date Received: \_\_\_\_\_  
Date Installed: \_\_\_\_\_  
Toll Free Telephone : 1(800)735-3853  
Fax: 1(314)231-5074  
Service Referral #: \_\_\_\_\_  
Local Service Name \_\_\_\_\_

Local Service # \_\_\_\_\_

### General Specifications

#### Overall Dimensions

Height: 33 5/8 in./85.5 cm  
Width: 32 7/8 in./83.5 cm  
Depth: 24 3/8 in./62 cm

#### Electrical:

TTM2-XXXX: 120 VAC, 14.3 Amps,  
1718 Walls, 50/60 Hz.

### Installation requirements

Power Connection: Dedicated 15 Amp,  
NEMA 5-15R  
Receptacle.

### Agency Approvals:



ALSO CLASSIFIED BY  
UNDERWRITERS LABORATORIES INC.  
IN ACCORDANCE WITH  
NSF No. 4 1999





# CAMPBELL'S® TABLETOP MERCHANDISER BY DUKE

## RESTAURANT EQUIPMENT MANUAL

### SPECIFICATION

#### TTM2-XXXX

Voltage: 120V:  
Amps: 14.3  
Watts: 1718



ALSO CLASSIFIED BY  
UNDERWRITERS LABORATORIES INC.  
IN ACCORDANCE WITH  
NSF No. 4 1999

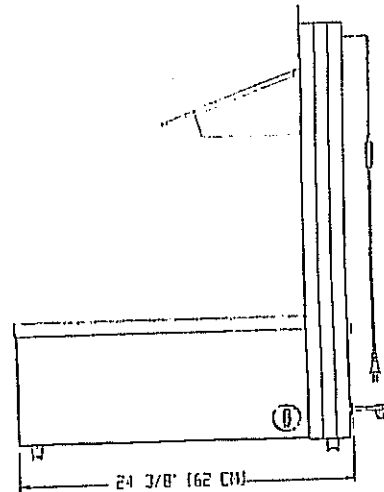
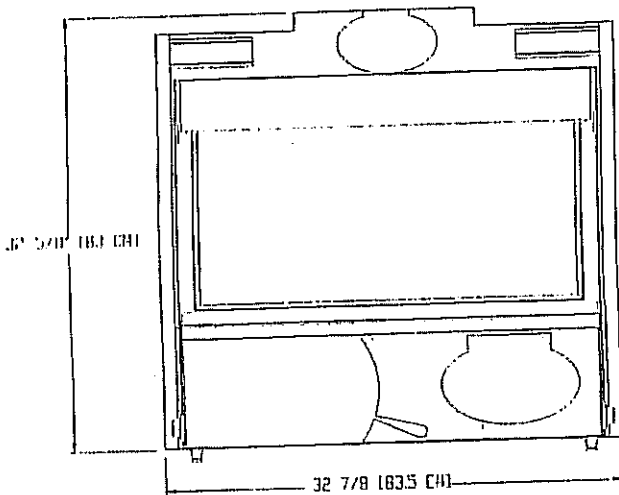
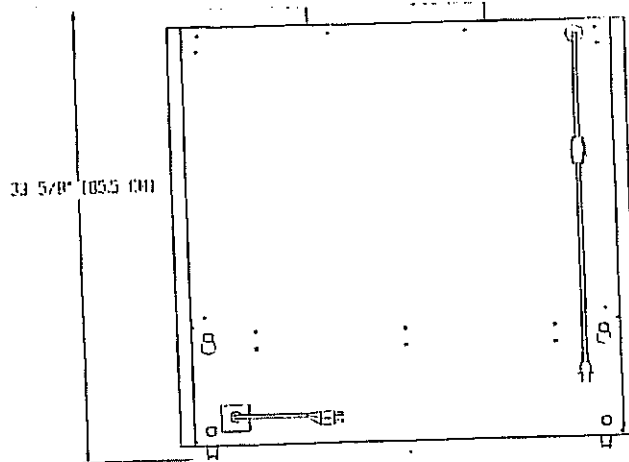
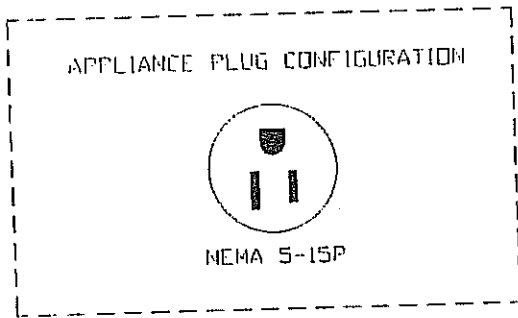

REVISED:  
September 25, 2003





## INSTALLATION INSTRUCTIONS

1. Ensure location selected for merchandiser has the proper-grounded receptacle within four feet of the final position of the merchandiser (see figure 2.1 below).

**CAUTION**  
**RISK OF ELECTRIC SHOCK!**  
**DO NOT REMOVE GROUNDING PIN FROM CORD! THIS MAY CAUSE THE APPLIANCE SKIN TO BECOME ENERGIZED AND POSE A SHOCK HAZARD!**

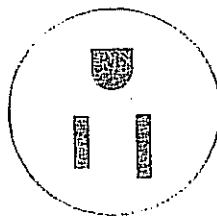

NEMA 5-15R

Figure 2.1 Required Receptacle Configuration

2. Remove merchandiser from packing material. Ensure all paper and plastic packing material is completely removed from merchandiser before plugging in to power source.
3. Inspect merchandiser for damage.
4. Position merchandiser on stable surface.
5. Ensure all four feet are touching the surface. Adjust feet as necessary (see figure 2.2 below).
6. Operate Merchandiser as described in the Periodic Maintenance, Checklist and Cleaning Guide section.

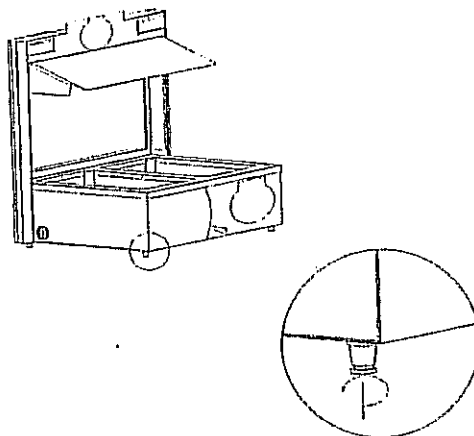
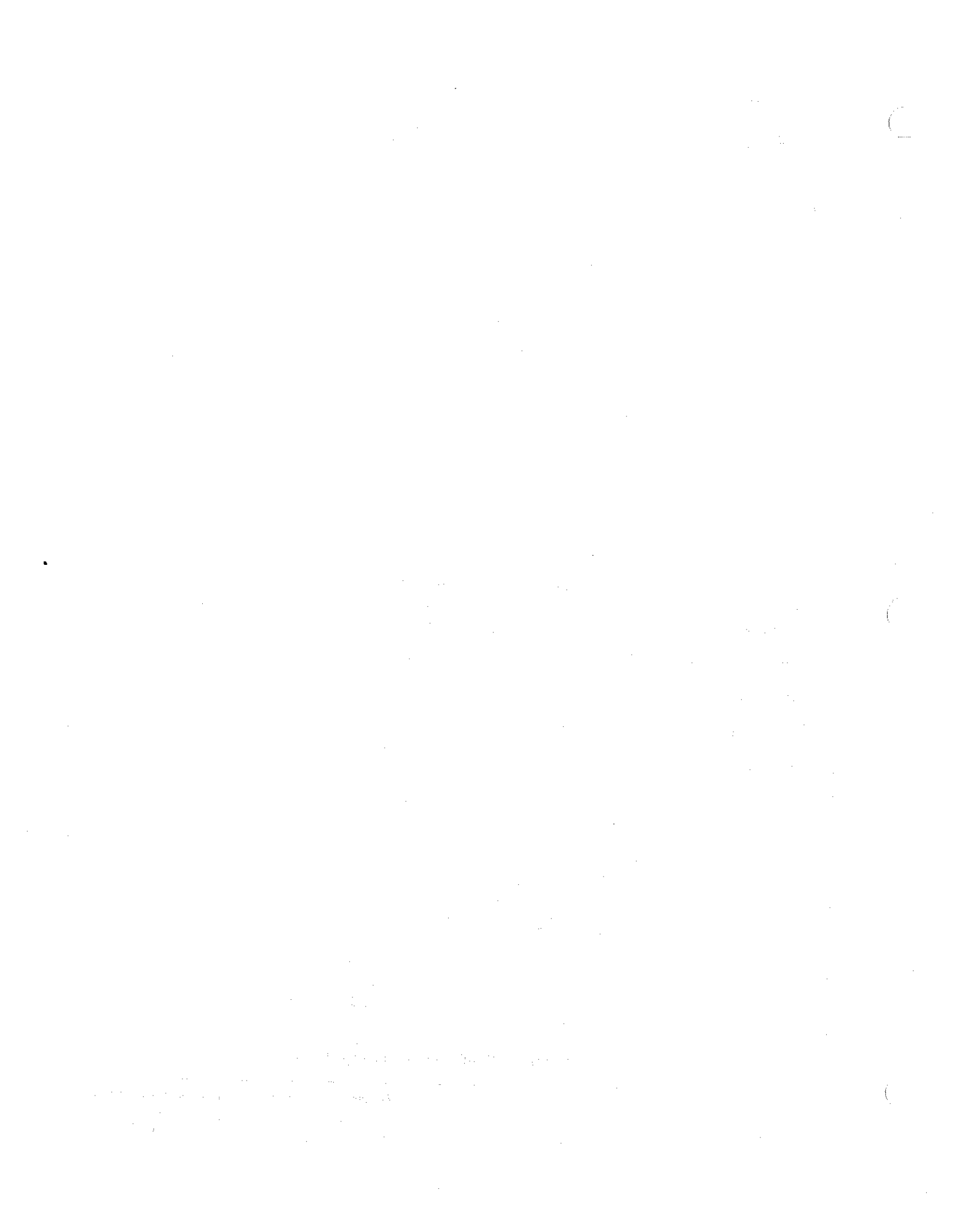
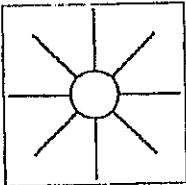

Figure 2.2 Merchandiser Foot Adjustment



PERIODIC MAINTENANCE, CHECKLIST AND CLEANING GUIDE

DAILY



OPENING CHECKLIST

1. Turn light switch to ON (figure 3.2, pg. 7).
2. Fill each well with 9 quarts of hot tap water. Note: The addition of 1 teaspoon of Cream of Tarter to water will aid in cleaning of wells at end of day.
3. Position template(s) (figure 3.1, pg. 6) on Countertop Merchandiser.
4. Place control knob(s) to HI (figures 3.3 and 3.4, pg. 8).
5. Allow Countertop Merchandiser to heat for at least 30 minutes or until water temperature reaches 175° F (80° C).

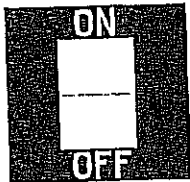

OPERATION

1. Prepare soup as described in the Campbell's® handling instructions.
2. Place hot soup 155° to 165° F (68° to 74° C) into 7-quart or 11-quart bain-marie (figure 3.1, pg. 6) as required.

CAUTION:

Wear insulated gloves to prevent burns from escaping steam when inserting or removing bain-marie into preheated countertop merchandiser.

3. Place bain marie into the desired position in template.
4. Place hinged cover on all bain-maries and any unused template positions.
5. Place the control knob(s) to 3.5.
6. Monitor water levels and add hot water as needed.





PERIODIC MAINTENANCE CHECKLIST AND CLEANING GUIDE

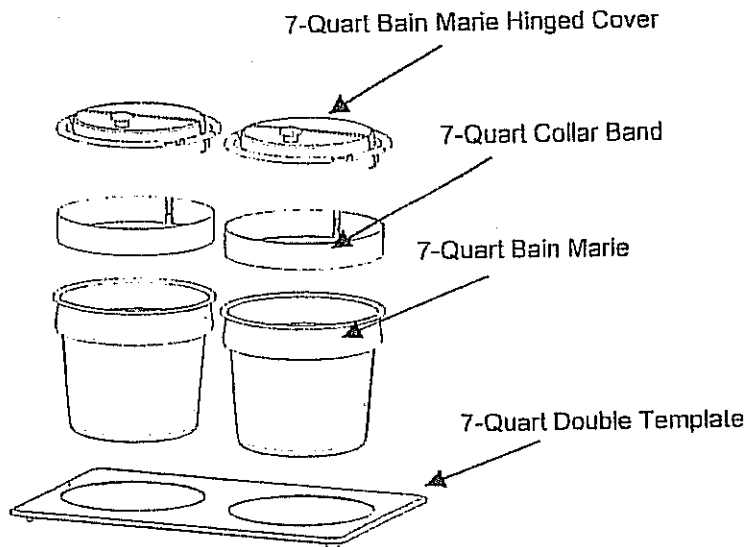
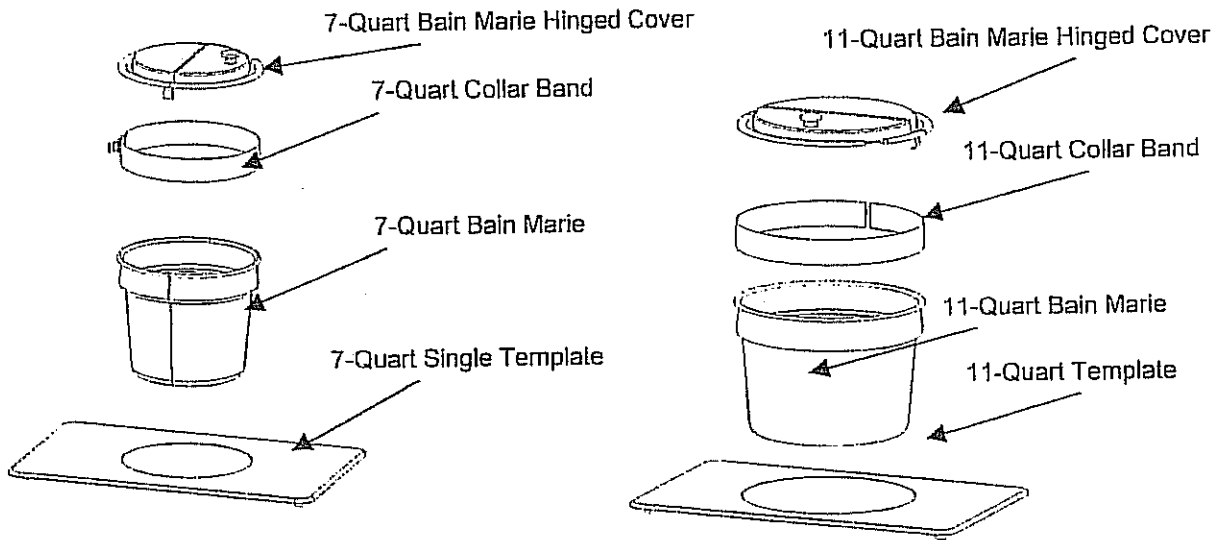

Figure 3.1 Merchandiser Component Names





PERIODIC MAINTENANCE CHECKLIST AND CLEANING GUIDE

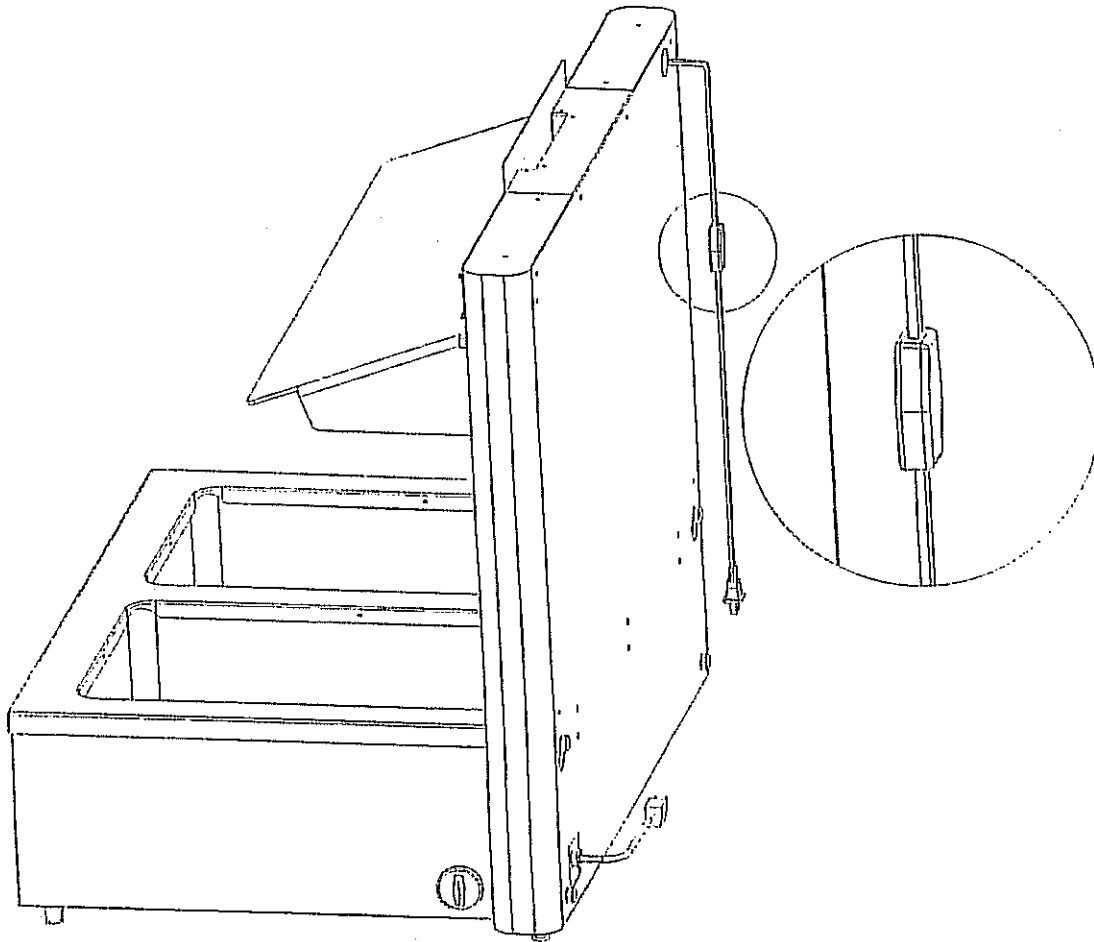

Figure 3.2 Light Switch





PERIODIC MAINTENANCE CHECKLIST AND CLEANING GUIDE

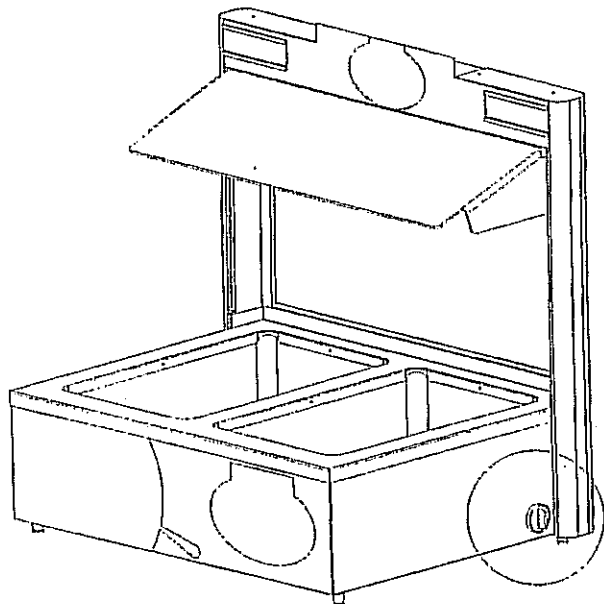

Figure 3.3 Right Heat Control

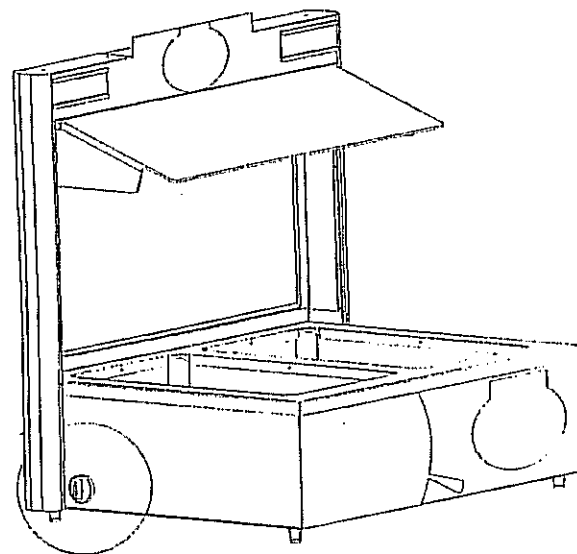
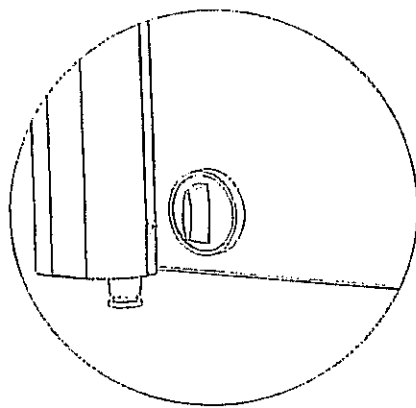

Figure 3.4 Left Heat Control





PERIODIC MAINTENANCE CHECKLIST AND CLEANING GUIDE

DAILY (cont'd)

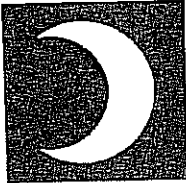

CLOSING CHECKLIST

1. Turn light switch and control knobs to OFF.
2. Unplug merchandiser from electrical receptacle.
3. Remove all pans and pan covers.
4. Allow merchandiser to cool for approximately 30 minutes or until water is cool enough to touch.
5. Clean Countertop Merchandiser as outlined in the **CLEANING INSTRUCTIONS**.

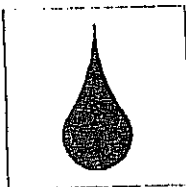

CLEANING INSTRUCTIONS

**Caution!**

Do not use caustic cleaners, acids, ammonia products, abrasive cleaners, or abrasive cloths. These can damage surfaces.

1. Complete steps described in the **CLOSING CHECKLIST**.
2. Remove templates from the merchandiser.
3. Empty water from the wells by first scooping most of the water out with a cup or pan. Then remove the remaining water with a sponge or a rag. **Do not attempt to dump water by tipping unit.**
4. Wipe down the interior, exterior, and templates of the Countertop Merchandiser with warm water and mild detergent using a soft cloth.
5. The Back Panel may be removed in order to better clean the merchandiser. Remove panel by first removing the bottom thumbscrews and loosening the top thumbscrews so that  $\frac{3}{4}$  of an inch of the threads are showing. Lift Back Panel so that the keyholes pass up and over the top thumbscrews' heads (figure 3.5, pg 10). Remove top thumbscrews and finish wipe down.
6. Reinstall the Back Panel by screwing the top thumbscrews so that  $\frac{3}{4}$  of an inch of the threads are showing. Lift Back Panel so that the keyholes pass up and over the top thumbscrews' heads. Tighten top thumbscrews and replace the bottom thumbscrews.

**Caution!**

Do not use caustic cleaners, acids, ammonia products, abrasive cleaners, or abrasive cloths. These can damage surfaces.

**Warning!**

Risk of electric shock. Do not use immerse in water.





PERIODIC MAINTENANCE CHECKLIST AND CLEANING GUIDE

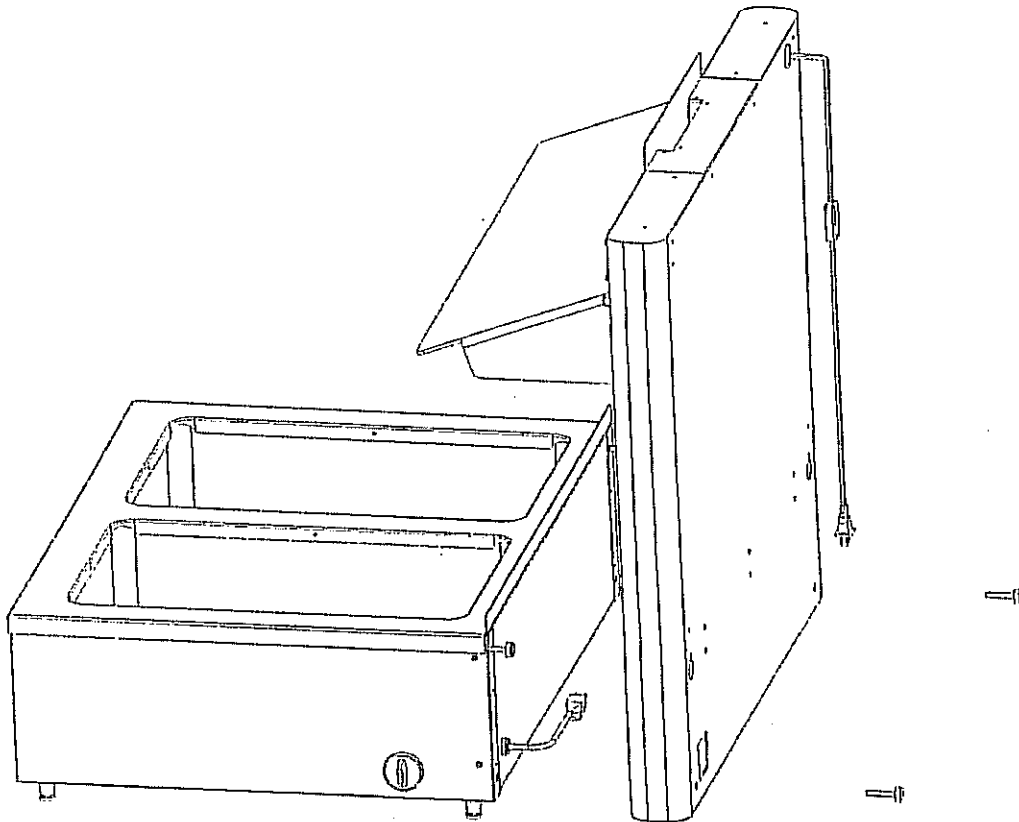

Figure 3.5 Back Panel Removal and Installation



## TROUBLESHOOTING

There are no user serviceable parts on the Campbell's® Tabletop Merchandiser. If a malfunction occurs, ensure unit is plugged in then check all switch and control positions. If the malfunction still exists, contact your Duke Manufacturing Company authorized service agent or call 1-800-735-3853 or 1-314-231-1130.





PARTS LISTS AND ILLUSTRATIONS

1	5046-2	THERMOSTAT, HIGH LIMIT
2	154036	ELEMENT, 850W, 120V.
3	216147	FOOT, ADJUSTABLE
4	2164-2	KNOB, CONTROL
5	5580-2	INFINITE SWITCH, 120 V

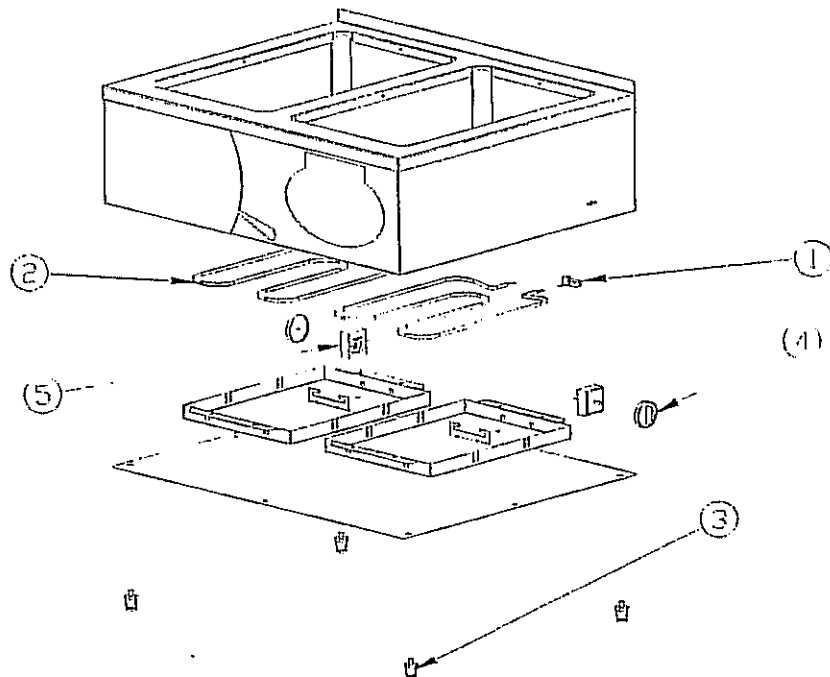
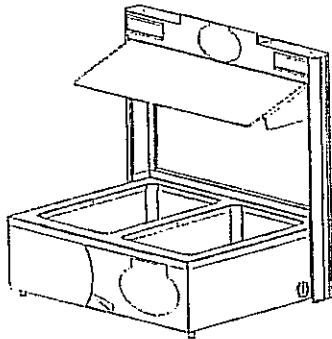

Figure 4.1, Merchiser Base Section





PARTS LISTS AND ILLUSTRATIONS

1	216152	LIGHT FIXTURE, W/LAMP AND COVER	
2	0651428	LAMP, FLOURENSCENT	T+
3	230365	CHORD AND SWITCH ASSEMBLY	

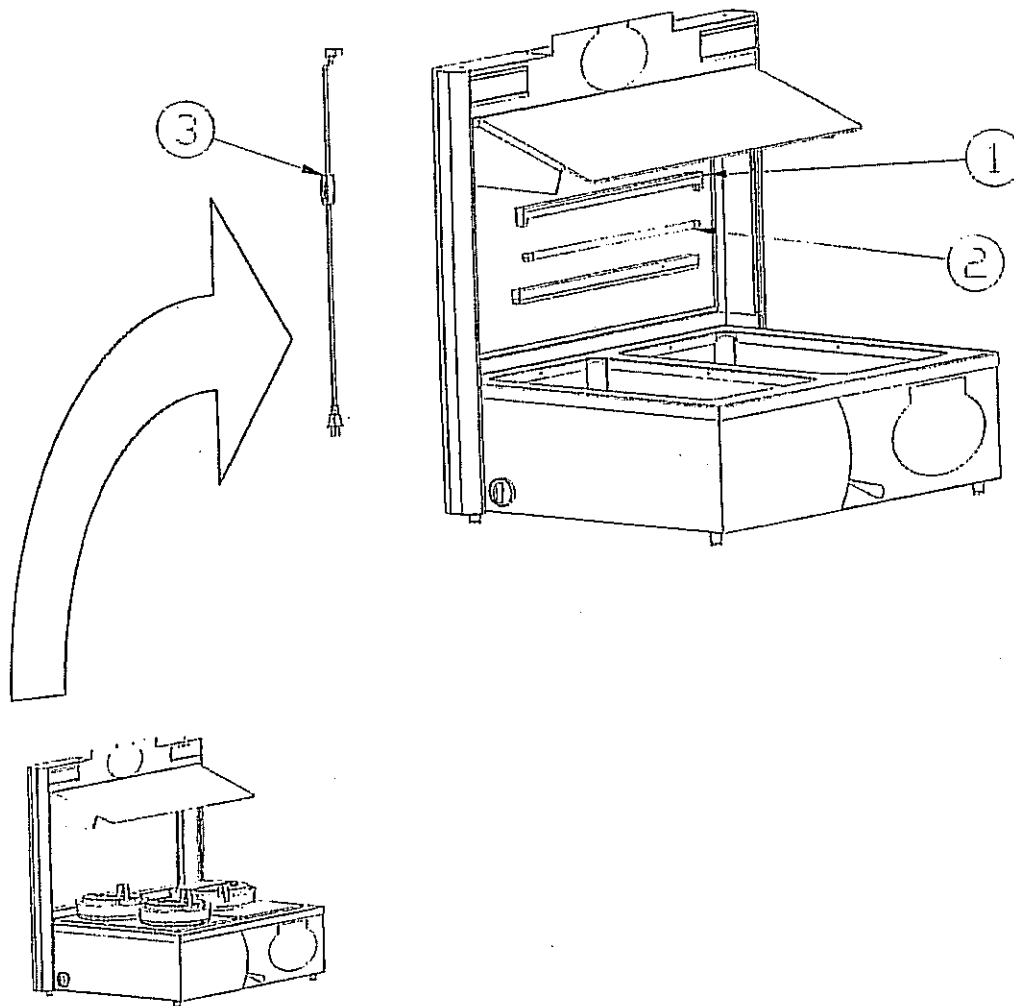

Figure 4.2, Merchandiser Tower Section





PARTS LISTS AND ILLUSTRATIONS

KIT, 11-QUART PAN AND TEMPLATE, Part Number 1643502

	1643505	11 QT PAN & TEMPLATE SET
1	0653114	TEMPLATE 11 QT
2	0651993	BAIN MARIE, 11-QUART
3	0643170	COLLAR SS 11-QUART PAN
4	0641995	LADLE, SOUP
5	0641994	COVER, HINGED, 11-QUART

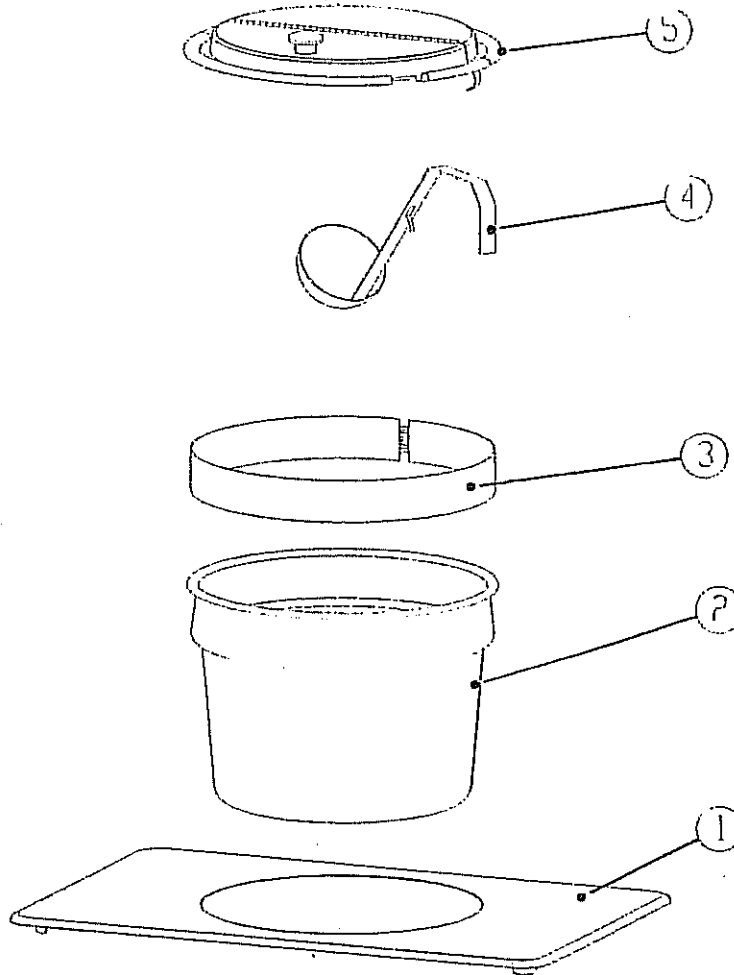

Figure 4.3, Pan Kit, 11-Quart, models TTM2-1111, TTM2-711 and TTM2-7711





PARTS LISTS AND ILLUSTRATIONS

KIT, 7-QUART DOUBLE PAN AND TEMPLATE, Part Number 1643501

	1643504	7 QT DOUBLE PAN & TEMPLATE SET
1	0653113	TEMPLATE DOUBLE 7 QT
2	0651337	BAIN MARIE, 7-QUART
3	0643171	COLLAR SS 7-QUART PAN
4	0641995	LADLE, SOUP
5	0651338	COVER, HINGED, 7-QUART

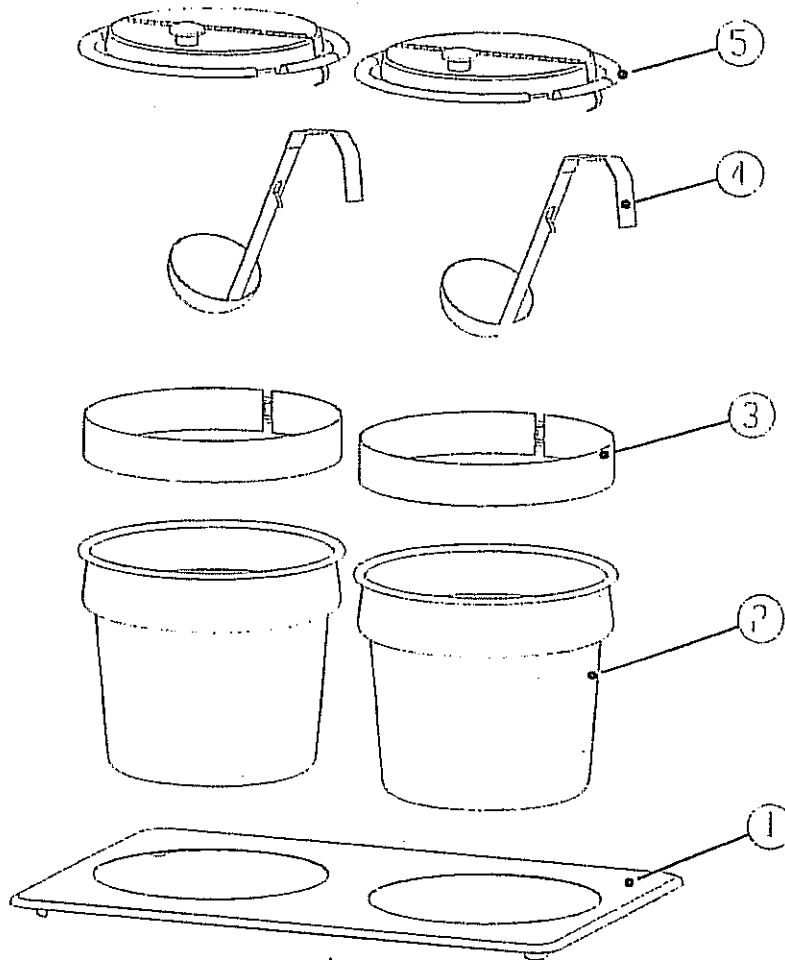

Figure 4.4, Pan Kit, 7-Quart, models TTM2-7777, and TTM2-7711





PARTS LISTS AND ILLUSTRATIONS

KIT, 7-QUART SINGLE PAN AND TEMPLATE, Part Number 1643503

	1643503	7 QT SINGLE PAN & TEMPLATE SET
1	0653115	TEMPLATE SINGLE 7 QT
2	0651337	BAIN MARIE, 7-QUART
3	0643171	COLLAR SS 7-QUART PAN
4	0641995	LADLE, SOUP
5	0651338	COVER, HINGED, 7-QUART

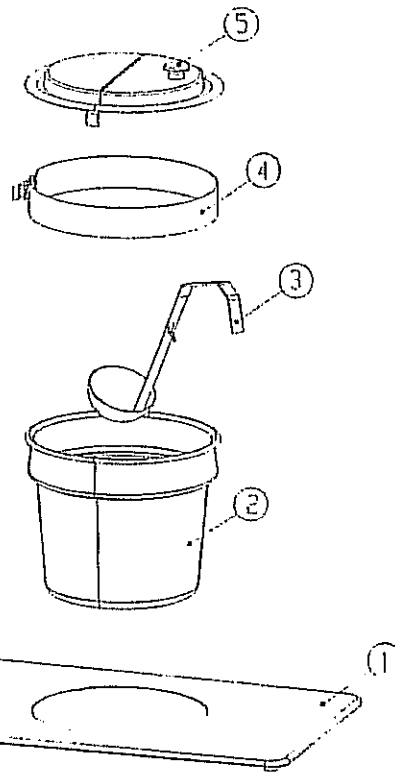

9 1/2" 0651338 7qt lid  
11 5/16" 0641994 11qt lid

Figure 4.5, Pan Kit, 7-Quart, models TTM2-77, and TTM2-711





WIRING SCHEMATIC

