



## ELECTRIC FOOD WARMERS

Installation

Operation

& Maintenance

Manual

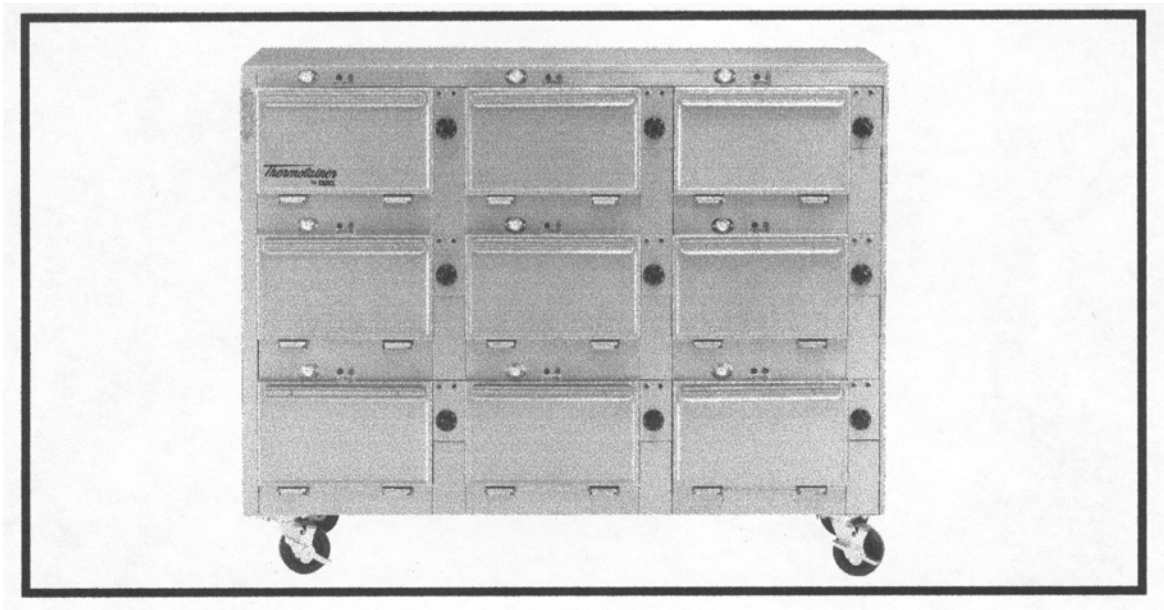

“Your Solutions Partner”

DUKE MANUFACTURING CO.  
2305 N BROADWAY • ST. LOUIS, MO 63102  
800.735.3853 • 314.231.1130 • 314.231.5074 Fax  
[www.dukemfg.com](http://www.dukemfg.com)

201351K

---

# INDEX

	<b>PAGE</b>
Principles of Operation	3
Installation Instructions	3
Cord & Plug Schedule	4
Electrical Connection Diagram	5
Operating Instructions	6-7
Care of Equipment	7
A. Heating Elements	7-9
B. Pilot Lights	9
C. Hinge and Door Adjustments	9-10
D. Damper Assembly	11
E. Replacement of Pilots Lights or Thermostats	11
Troubleshooting	12
Recommended Food Storage Periods	13
Parts List	14-15
Unitrack Assembly	16
Door Styles	17
Angle Slides	18-19
Number of Elements per Unit	20

Please supply the ID Number and the Serial Number when ordering replacement parts or requesting service.

**We recommend service by Duke Authorized Service Agencies during and after the warranty period.**

---

## PRINCIPLES OF OPERATION

The Thermotainer has been designed to preserve hot food at its proper temperature in its own moisture, without the addition of water, steam or circulating fans. The hot air surrounding the food compartment is electrically heated and automatically controlled to maintain the desired temperature. Each cabinet has one or more thermostats depending upon its design and model number. Each compartment has a vent or damper for the control of moist or dry foods.

The primary function of a Thermotainer is for the intermediate storage of hot food after it leaves the cooking unit until it is ready to serve. Thermotainers are not designed to reheat food that has cooled, thawing frozen food, or for cooking. These uses are not recommended.

## INSTALLATION

The Thermotainer, when it leaves the factory, is assembled and ready for Installation. The nameplate on the thermostat side of the cabinet contains model number, serial number, volts, hertz, wattage and instructions on the damper operation. The Thermotainer must be connected to the proper electrical power source as indicated on the nameplate. Failure to do this may cause serious damage, prevent proper operation and void the manufacturer's warranty.

The access to the electrical connection box is normally located at the lower front (thermostat side) bottom. It is covered with an access cover panel that is held in place by two screws. Concealed, but adjacent to the right side of the electrical connection box is a wire chase that runs front to back. It is visible by looking underneath the unit. The wire chase permits access to the side knockout of the electrical connection box and to "stub up" or rear connects the electrical power source. Some Thermotainers may be equipped with cords and plugs or the electrical connection box may be in another location depending upon the design and location that may have been specified. It is not necessary to disassemble any part of the Thermotainer to make the electrical connection.

Thermotainers should be moved by carefully lifting underneath and placed in the desired location. They should not be pushed or shoved as this may damage the legs, the hardware, or the electrical components. After setting in place, the Thermotainer must be leveled. If equipped with legs, the adjusting feet should be turned to level the cabinet.

**THERMOTAINER® CORD & PLUG SCHEDULE**

			MAX.	CORD	NEMA	NEMA
WATTAGE	VOLTS	PHASE	<u>AMPS</u>	<u>SIZE</u>	<u>PLUG</u>	RECEPTACLE
Up to 1800	120	1	15.0	14-3	5-15P	5-15R
1800 - 1920	120	1	16.0	14-3	5-20P	5-20R
1920 - 2700	120	1	22.5	12-3	5-30P	5-30R
2700 – 4500	120	1	37.5	8-3	5-50P	5-50R
Up to 3120	208	1	15.0	14-3	6-15P	6-15R
3120 – 3328	208	1	16.0	14-3	6-20P	6-20R
3328 – 4680	208	1	22.5	12-3	6-30P	6-30R
4680 – 7800	208	1	37.5	8-3	6-50P	6-50R
Up to 5757	208	3	16.0	12-4	15-20P	15-20R
5757 – 8096	208	3	22.5	10-4	15-30P	15-30R
8096 – 13493	208	3	37.5	6-4	15-50P	15-50R
Up to 3600	240	1	15.0	14-3	6-15P	6-15R
3600 – 3840	240	1	16.0	14-3	6-20P	6-20R
3840 – 5400	240	1	22.5	12-3	6-30P	6-30R
5400 – 9000	240	1	37.5	8-3	6-50P	6-50R
Up to 6643	240	3	16.0	12-4	15-20P	15-20R
6643 – 9342	240	3	22.5	10-4	15-30P	15-30R
9342 – 15570	240	3	37.5	6-4	15-50P	15-50R

## Thermotainer Electrical Connection Diagram

MODEL NUMBER				"A" DIM.	"B" DIM.	"C" DIM.
1101-1101P	1154-1154P	1453-1453P	1553-1553P	16-	32"	12"
1102-1102P		1454-1454P	1554-1554P			
1103-1103P		1455-1455P	1571-1571P			
1104-1104P		1456-1456P	1572-1572P			
1151-1151P		1458-1458P	1573-1573P			
1152-1152P	1262-1262P	1551-1551P	1574-1574P			
1153-1153P	1452-1452P	1552-1552P				
1201-1201P	1204-1204P	1304-1304P	1308-1308P	11-1/2"	27"	7-12"
1202-1202P	1302-1302P	1305-1305P	1309-1309P			
1203-1203P	1303-1303P	1306-1306P				
1352-1352P				19 1/2"	27"	15-1/2'
1353-1353P				21-1/2"	27"	17-1/2"
1351-1351P						
2352-2352P						
2353-2353P						
1601-1601P	1603-1603P			13-1/2"	27-1/2"	9 1/2"
1602-1602P				18"	32-	14"
1651-1651P	2103-2103P	2454-2454P	2466-2466P			
1652-1652P	2104-2104P	2456-2456P	2468-2468P			
1653-1653P	2452-2452P	2458-2458P	2652-2652P			
2101-2101P	2453-2453P	2464-2464P	2653-2653P			
2102-2102P						
1652A				18"	23-1/2"	14"
2201-2201P	2302-2302P	2308-2308P	2318-2318P	13-1/2"	27-	91/9"
2202-2202P	2303-2303P	2309-2309P	2602-2602P			
2203-2203P	2304-2304P	2314-2314P	2603-2603P			
2204-2204P	2306-2306P	2316-2316P				
1253-1253P				16"	34"	12"

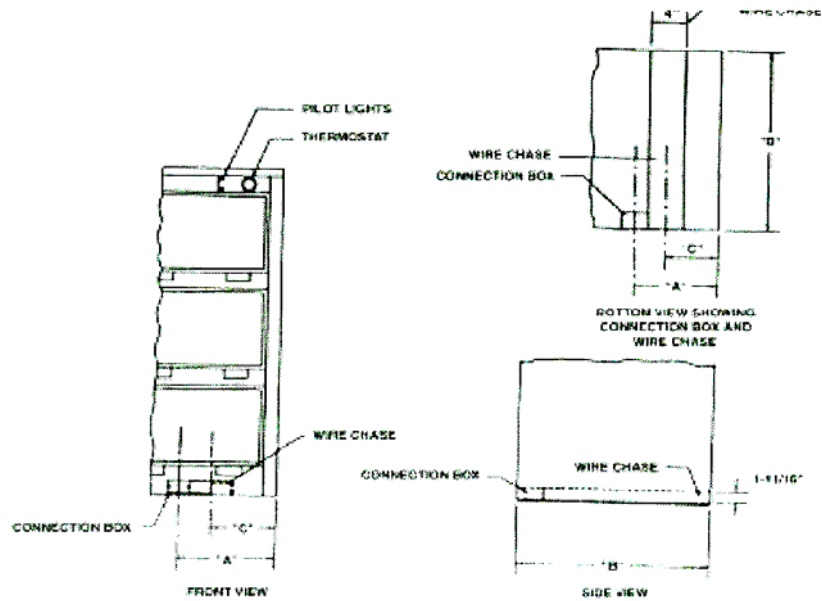

---

If legs were not supplied, it may be necessary to shim under the bottom to level. After leveling, with the thermostat (s) in the off position, the Thermotainer can be connected to the electrical power source. Installation must be in accordance with national or local electrical and sanitation codes. In order to remain in compliance with NSF standards, the base must be sealed to the counter or floor. Use General Electric RTV-102, Dow Corning 781 Building Sealant or any silicone based product, which is approved and acts as an adhesive/ sealant.

When the electrical connection is completed, install the stainless steel angle slides inside the compartments. Clean and polish the inside and outside before preheating for the first time. This will assure the factory finish remaining bright for years. See **Care of the Equipment** section of this manual.

### **Electrical Control**

The temperature is maintained by a thermostat (s) that can be adjusted to the desired temperature. The thermostat is directly connected to the heating elements, which in turn heat the air space surrounding each compartment. A thermostat may control one or more compartments depending upon the design.

Each Thermotainer is carefully inspected and tested at the factory. The thermostat (s) are adjusted and calibrated with precision temperature indicating instruments.

The thermostat dial temperature numbers may not necessarily indicate the exact compartment temperature. After it has been determined by use at which setting food keeps best, the thermostat should be kept at this setting to maintain this temperature. Your own experience will be the best guide. Do not constantly change the thermostat setting once it has been determined unless the foods being stored require different temperatures.

**NOTE: Thermostats are factory calibrated. Field calibration of the thermostat is not covered by warranty. Preheating**

To prevent food spoilage and harmful bacteria growth, food should not be placed in a cold Thermotainer. Preheat by turning the thermostat knob to the desired temperature setting. Allow at least 1-1/2 hours to reach the set temperature.

In heating a cold unit, set the thermostat to the desired temperature. Do not turn to a higher setting as this will waste energy, cause the Thermotainer to be heated above the desired temperature and will not increase the speed of preheating.

## **OPERATING INSTRUCTIONS**

When the operating temperature has been reached, the red pilot light will go out. (It cycles on and off as the temperature varies in the compartment.) The Thermotainer is now ready to accept food for storage. If the food is to be served in the same pan in which it was cooked, it may be left in this pan and placed in the compartment. Otherwise pan food immediately after cooking into another utensil and place in the compartment. The Thermotainer keeps the food in perfect condition during the interval between cooking and serving.

**All foods should be placed in the compartment while hot. The use of the Thermotainer for reheating or warming cold food is not recommended. If the Thermotainer is to be used for reheating food, consult a competent food or health authority for information concerning which foods may be cooled and reheated safely.**

Most foods can be kept in their best condition at a temperature of approximately 175°F (79.4°C), but the exact temperature will vary with the kind of food and the method of preparation. Minor temperature fluctuations will not affect the quality of most foods. It is not possible to give exact instructions that will fit all conditions. It is suggested that you experiment by increasing or decreasing the temperature until you find the most suitable temperatures for various types of foods. For suggested temperature settings, consult the food storage instruction sheet on page 16.

---

**IMPORTANT HEALTH WARNING:** The minimum FDA/NSF temperature for storing hot food is 140°F (60°C). Some local health codes require a minimum of 150°F (65.5°C). Consult your local health code or inspector to determine the minimum safe storage temperature for your area. Storing hot food below 140°F (60°C) may cause the growth of harmful bacteria, which can result in food poisoning.

Some "dry" type food, such as breaded meats, fish, etc., when kept at their proper temperature, require less moisture in the compartment to prevent sogginess. For this reason, all compartments are equipped with vents or dampers. For "dry" type foods the damper should be open. For "moist" type foods the damper should be closed. Refer to the damper operating instructions on the nameplate. Keep the damper in either full open or full closed position depending upon the food being stored. With a little experience, you will soon know the proper position.

Some foods can be kept in good condition much longer than others can, and certain foods cannot be satisfactorily stored in any manner. This depends upon the type of food and method of preparation. Do not expect the impossible from the Thermotainer. If used properly and within its design limitations, it will keep food with less deterioration and for a longer period of time than is possible with other equipment. By maintaining the quality between the time the food is cooked and served, the Thermotainer will assure food being served in the best possible condition.

## CARE OF EQUIPMENT

The exterior and compartments should be cleaned daily. Turn off the power before cleaning. Avoid using excessive amounts of water. A damp cloth and any good grease solvent, commercial detergent, or soap should remove any food that has spilled. Do not use harsh scouring powders, steel wool, toxic chemicals, or abrasive cleansers. Thoroughly rinse after using cleaning compounds.

**NOTE: Never steam clean or hose down with water. Electric components will fail due to moisture.**

If you have been using the compartments with the damper continually open, at least once a week set the thermostat at 200°F (94°C) for several hours with the doors propped open, the dampers open, and the compartments empty. This will drive off any excessive moisture, which may have accumulated in the heater compartment. Remember to turn off the thermostat and close the doors after you have completed this operation.

### A. Heating Elements

Should the Thermotainer fail to heat or reach the desired temperature, first check the fuses or circuit breakers in the electrical power line to the Thermotainer. If the fuses or circuit breakers are operating, a qualified electrician, experienced maintenance personnel, or service agency should do further inspection. If you are not qualified to perform service, you may cause damage to the Thermotainer or injure yourself.

To inspect, service, or replace the heating elements, see the accompanying diagrams in this manual. To service, special tools are not necessary. Do not excessively force or jam any parts as Thermotainers are designed for field service and disassembly.

If the fuses or circuit breakers are in operating order, before disassembling to inspect the heating elements, using a voltmeter, check the electrical connections at the connection box, also before and after the thermostat is in its "on" position. This will determine if current is flowing to and through the thermostat. If there is no current flow, the thermostat may have malfunctioned or there may be a break in the wiring circuit. This requires a replacement of the thermostat or repair of the wiring circuit, not a heating element replacement.

If power is flowing through the thermostat, an alternate check can be made with an ammeter. With the thermostat in the "on" position, the ammeter should record amperes approximately equal to the total wattage divided by the voltage. Example: A single phase Thermotainer with a 2750 watt rating at 208 volts

---

**TYPICAL DIAGRAMS SHOWING HOW TO REMOVE COMPARTMENT AND DOORS FOR INSPECTION OR REPLACEMENT OF HEATING ELEMENTS IN THERMOTAINERS**

Diagram showing how to remove compartment for inspection or replacement of heating element in Thermotainers.

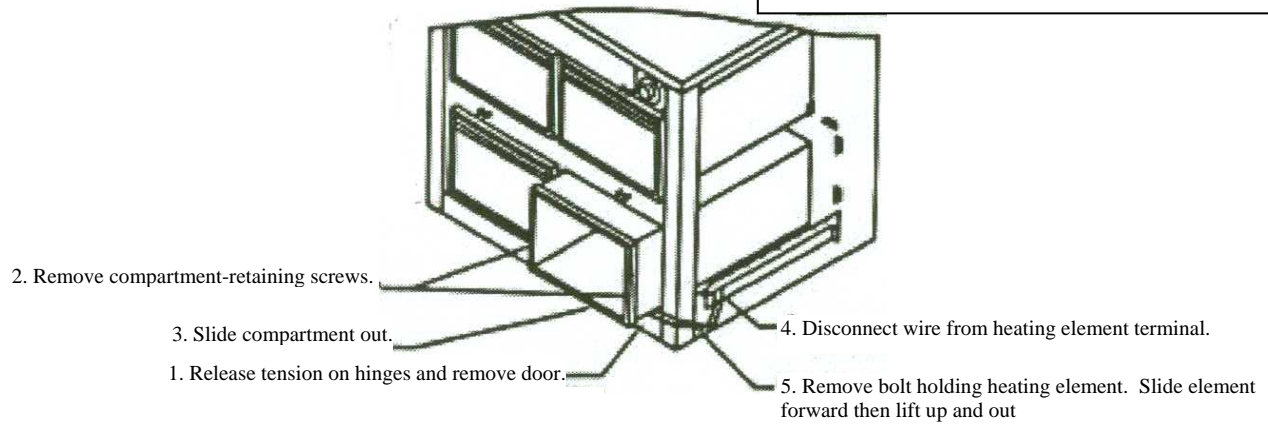
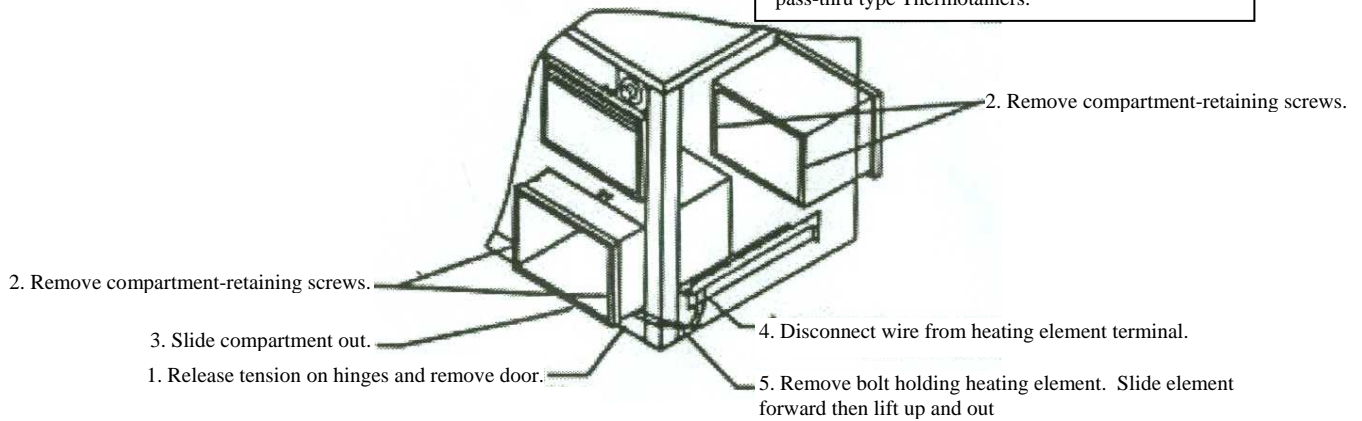

Diagram showing how to remove compartment for inspection or replacement of heating element in a pass-thru type Thermotainers.



---

should read about 13.2 ampere. If the reading is much less or zero, one or more heating elements may need replacement.

To use this test you must observe the design of the Thermotainer as to the number of thermostats and location of the heating elements. Thermotainers with only one thermostat have all heating elements located at the bottom of the cabinet in the air space, on either side and between each bottom compartment. Thermotainers with multiple thermostats will have heating elements at various locations depending upon the model.

### B. Pilot Lights

1. When power is connected to the Thermotainer the amber pilot light will glow continuously. Any interruption of the power source will extinguish the light. This may be caused by power, fuse or circuit breaker failure. The amber pilot light will continue to glow after the thermostat and heating elements shut off and the Thermotainer is not in use. The cost of pilot light operation is negligible. Make no attempt to remove or shut it off — it is an added protection.

2. The red pilot light will glow when the thermostat is turned on and will go off and on as the thermostat cycles to maintain the temperature setting selected. When the red pilot light does not glow after cycling, the Thermotainer is at the set temperature.

3. Removal and replacement of pilot lights and thermostats are covered in the **Thermostat Recalibration Instruction** section of this manual.

### C. To Adjust Hinges

The exclusive Thermotainer adjustable stop hinge is specially designed to provide sanitary construction and to withstand rugged service. It will easily support all reasonable and normal loads placed upon the door. Should tension of the internal concealed spring be lessened by use, the hinge can be easily adjusted with a thin rod, such as an ice pick or a piece of wire coat hanger. Simply place the end of the rod in one of the tension adjustment holes and rotate the assembly

upward, resetting the set pin when the proper tension is reached. Be careful not to adjust the spring tension too tightly. Usually resetting the set pin one hole is adequate. When the spring is properly adjusted, the doors will close firmly without slamming. Too much spring tension will cause the doors to slam and may result in premature failure of the door or hinge parts.

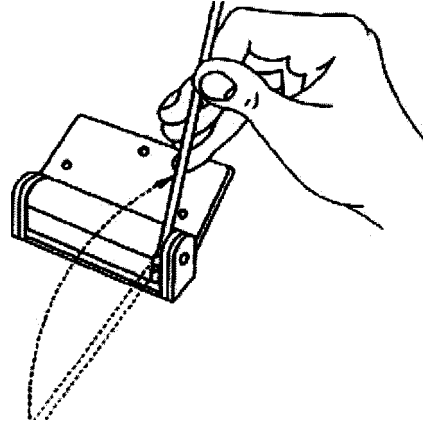

The hinge has been designed so all parts are replaceable. It is usually not necessary to order a complete replacement hinge. The parts list in the back of this manual illustrates and lists all the hinge parts. By only ordering parts that need replacement, maintenance costs can be reduced.

**CAUTION: The hinges and doors are not intended to serve as stepladders or to support abnormal loads. They will support the weight of food products normally encountered in food service.**

#### To Remove Door

1. Release spring tension on hinges.
2. Remove the three countersunk screws on each side of the inner door panel attaching the door to the hinge. Pull door loose from the hinge plates.

#### To Reinstall Door

Slide hinge plates into slots at bottom of the door and align countersunk holes in door with tapped holes in hinge plate. Install screws firmly using a thread tightening compound. Reset spring tension.

---

## To Remove Hinge Assembly

Thermotainer's exclusive hinge is designed so all parts are removable. It is not necessary to replace the complete hinge, only the part that requires replacement.

1. Release the spring tension by removing the set pin, Part TA-10. See Illustration,
2. Remove screw and lock washer in the end of the barrel cap nut and pull cap off the shaft. Using a small rod or screwdriver, drive the shaft and cap out of the barrel, or pry out with a screwdriver from the capped end.
3. If only internal parts are to be replaced, pull door out far enough to push parts out of the barrel, replace parts, and reassemble, reversing the above procedure.
4. If the entire hinge is to be replaced, proceed as in Items 1 and 2 above, then remove hinge plate as in **To Remove Door** instructions.
5. To remove the hinge base plate from the front of the cabinet, proceed as in Items 1 and 2 to gain access to the attaching screws. Remove screws.
6. To install a complete hinge assembly including the hinge base plate:
  - a. Reverse procedure in Item 5.
  - b. Reverse procedure in **To Remove Door** instructions.
  - c. Use procedure in Item 3
  - d. Hold internal parts in the barrel and insert base plate.
  - e. Insert shaft with cap.
  - f. Install cap, lock washer and screw. Tighten screw securely using thread-locking compound.
  - g. Set spring tension and install lock pin as instructed in **To Adjust Hinge**.

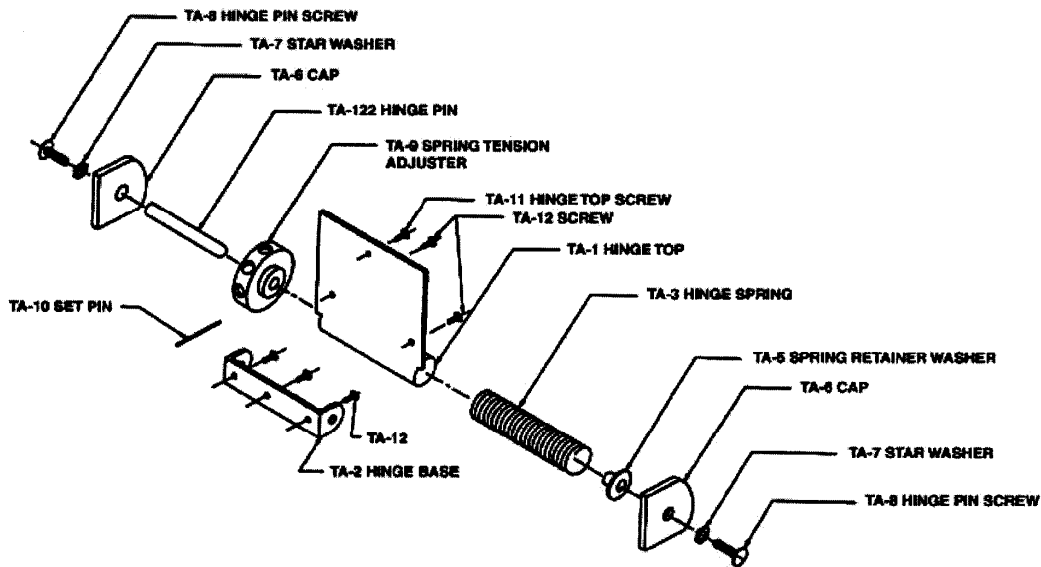

---

## D. To Remove Damper Assembly

1. If the Thermotainer has only one thermostat, remove the compartment directly above the damper, or if a pass-thru model, the front (thermostat side) of the compartment. If the damper is for the top compartment, remove the top panel. If the Thermotainer has a thermostat controlling each compartment, remove the compartment below the damper.
2. Remove the two screws attaching the actuating mechanism to the front of the inner liner.
3. Flex the damper rod sufficiently to slide the rear end out of the retaining hole. Then, moving the assembly toward the corner of the cabinet, flex the rod to allow push buttons to slide free of the front liner.

**CAUTION: Flex the rod gently so it does not become permanently bent or damaged. Lift free of cabinet. To reinstall, reverse this procedure. If rod becomes bent, straighten rod after reinstalling.**

4. To remove the push buttons, grasp button firmly with pliers and with a slight twisting motion, pull knob off in a straight direction. To install a new push button, place the hole in the push button over the end on the rod and gently push button on rod until it stops. Do not use excessive force when grasping, pulling, or pushing the button, as it will break.

## E. To Replace Pilot Lights or Thermostats

1. Shut off electric power to the Thermotainer.
2. Pull off the thermostat control knob.
3. Remove two screws at either end of the control panel and pull control panel out of cabinet. If the Thermotainer has a flush top panel with a turned down edge, slide the control panel from under the edge.
4. Remove two screws that hold the thermostat to the control panel, disconnect wiring, and pull the thermostat capillary tube and bulb straight out of the cabinet.
5. Pry lock nut off the back of the pilot light and pull pilot light out through front of control panel after disconnecting the wire to the pilot light.
6. To replace thermostat or pilot light, reverse this procedure. After installing a new thermostat, it should be checked with a thermometer.

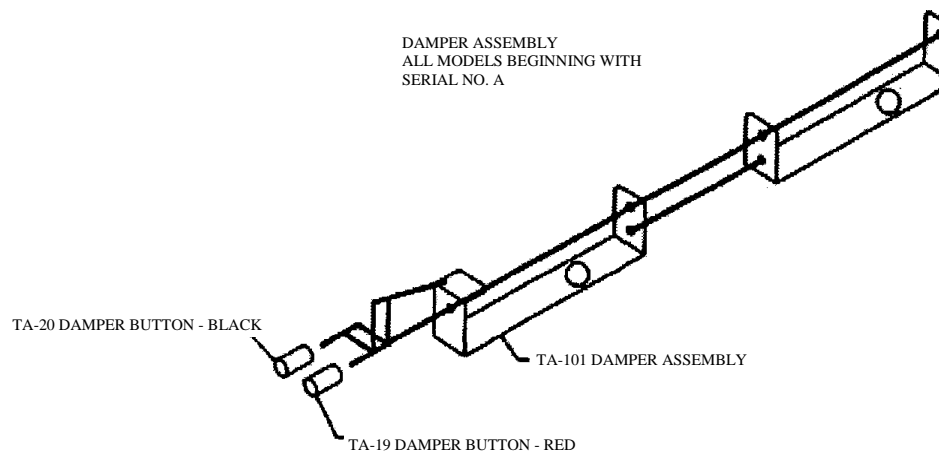

## TROUBLESHOOTING

<b>PROBLEM</b>	<b>CAUSE</b>	<b>CORRECTION</b>
Doors do not close. Drop Door models only.	Hinge tension needs adjustment or replacement of springs.	Adjust spring tension by removing TA-10 set pin and rotating TA-9 adjuster upward one or two holes. Reset TA-10 set pin. Do not over-tighten spring. If adjuster does not tighten spring, disassemble hinge and replace TA-3 spring. See <b>To Adjust Hinge</b> section.
Compartment not heating.	Failure at power source. Defective thermostat. Defective heating elements. Broken wire. Disconnected element terminal.	Check fuses or circuit breakers. Check connections in junction box. If amber pilot light is glowing, there is power up to the thermostat. If red pilot light is glowing, there is power after thermostat. If red pilot light is off, first test pilot light. If operative, replace thermostat. If both pilot lights are glowing, check circuit for broken wire or loose terminal if none of these, remove compartment and replace heating element located on each side of the bottom air space surrounding compartment. See <b>Heating Element</b> section.
Compartment overheating.	Thermostat defective or requires recalibration.	Recalibrate thermostat in accordance with instructions. If recalibration does not eliminate overheating, replace thermostat.

---

## RECOMMENDED FOOD STORAGE PERIODS

<u>Crisp or Dry Foods</u>	<b>Longest Time Kept</b>	<b>Average Time Kept</b>	<b>Approximate Temperature F°</b>
Baked potatoes	2 hrs.	30 min.	175-200
Corn Sticks	2 hrs.	1 hr.	140-150
Crackers	8 hrs.	5 hrs.	140-150
Chicken pies	6.hrs.	3 hrs.	175-200
Club sandwiches (wrapped)	1 hr.	30 min.	160
Fried chicken	6 hrs.	3 hrs.	175-200
Fried sea foods	6 hrs.	3 hrs.	175-200
Hard rolls	8 hrs	4 hrs.	140-150
Hot mince or apple pies	6 hrs.	4 hrs.	160
Meat pies	5 hrs.	3 hrs.	175-200
Popcorn & potato chips	10 hrs.	5 hrs.	150
Popovers	2 hrs.	1 hrs.	140-150
 <b><u>Moist Foods</u></b>			
Baked beans	8 hrs.	4 hrs.	175-200
Baked stuffed lobster	3 hrs.	2 hrs.	175-200
Biscuits	1 hrs.	30 min.	150-175
Casseroles (w/o top crust)	8 hrs.	4 hrs.	175-200
Chop Suey	6 hrs.	4 hrs.	200
Deviled crabs	5 hrs.	3 hrs.	175-200
Frankfurter buns	6 hrs.	3 hrs.	160-175
Hash	4 hrs.	2 hrs.	175-200
Hot puddings	8 hrs.	4 hrs.	150-200
Mashed potatoes	3 hrs.	2 hrs.	160-180
Meats – ready for serving	4 hrs.	2 hrs.	175-200
Muffins & corn bread	8 hrs.	3 hrs.	140=150
Soft rolls	12 hrs.	4 hrs.	
Stews – ready for serving	4 hrs.	2 hrs.	175-200
Sweet Rolls	4 hrs.	2 hrs.	140-150
Stuffed pork chops	4 hrs.	2 hrs.	175-200
Vegetables – ready for serving	6 hrs.	2 hrs.	175-200
Turkey with dressing	3 hrs.	2 hrs.	175

**IMPORTANT:** Above times and temperatures are meant to serve only as a guide. Types of food, methods of preparation, quantity, recipes, etc., will affect holding time and food quality. Experimentation on the part of the user will determine best results

All foods should be placed in the compartment hot. The use of the Thermotainer® for reheating food that has cooled or has been refrigerated is not recommended. If foods are to be reheated, consult a competent food or health authority for information concerning foods, which may be cooled and reheated safely.

---

## PARTS LIST

**IMPORTANT: State serial number, model number and complete electrical information when ordering parts. THE COMPANY WILL NOT BE RESPONSIBLE FOR OPERATION OF THE APPLIANCE UNLESS AUTHORIZED FACTORY PARTS ARE USED WHEN REPLACEMENTS ARE REQUIRED.**

<b>PART#</b>	<b>DESCRIPTION</b>
201068.	Angle slide, 5" – 25 ¾"
201069	Angle slide, 3" - 22-3/4"
201070	Angle slide, 5" - 29-3/4"
201374	Spacer, door handle (1")
201404	Hinge, Kasson
201417	Damper weld assembly
313021	Screw, 10-24, 5/8" round head
TA-1	Hinge top
TA-2	Hinge base
TA-3	Hinge spring
TA-5	Spring retainer washer
TA-6	Cap
TA-7	Lock washer
TA-8	Hinge pin screw, 8-32
TA-9	Tension adjuster
TA-10	Set pin
TA-11	Hinge top screw
TA-12	Screw, 10-24
TA-120.	Hinge assembly
TA-122	Hinge pin
TA-14	Door handle, 15-1/2"
TA-14A	Door handle, 23-1/2"
TA-14B	Door handle spacer, 1/2"
TA-14C	Door handle screw
TA-144	Thermometer, 1"
TA-15	375 watt heating element, 120 volt
TA-15A	375 watt heating element, 208 volt
TA-15B	375 watt heating element, 240 volt
TA-15C	375 watt heating element, 480 volt
TA-16	500 watt heating element, 120 volt
TA-16A	500 watt heating element, 208 volt
TA-16B	500 watt heating element, 240 volt
TA-17	750 watt heating element, 120 volt
TA-17A	750 watt heating element, 208 volt
TA-17B	750 watt heating element, 240 volt
TA-17C	750 watt heating element, 440 volt
TA-17D	750 watt heating element, 480 volt
TA-18	1000 watt heating element, 120 volt
TA-18A	1000 watt heating element, 208 volt
TA-18B	1000 watt heating element, 240 volt
TA-18C	1000 watt heating element, 440 volt
TA-19	Damper button, red
TA-20	Damper button, black
TA-21	Thermostat w/o knob, single phase
TA-22	Thermostat w/o knob, 3 phase
TA-23	Thermostat w/o knob, 3 phase, 440 volt
TA-24	Thermostat knob, (indicators on top)
TA-24A	Thermostat knob, (indicators on side)
TA-25	Pilot light, red

---

**PARTS LIST FOR ALL MODELS BEGINNING WITH SERIAL NUMBER**

TA-26	Pilot light, amber
TA-31	5" caster, stationary
TA-315	Leg, S/S
TA-32	5" caster, swivel with brake
TA-320	Thumbscrew, 8-32
TA-327	Support stud, pan rail
TA-348	Screw, 6-32, 3/4"
TA-36A	Uni-dor roller
TA36B	Uni-dor stop
TA-36HA	Uni-dor arm assembly, 2 each arm
TA-36J	Uni-dor arm link
TA-36A	Uni-dor- spring
TA-36L	Stainless steel cotter pin
TA-36M	Stainless steel castellated nut
TA-37	Door, "C" style, 10-1/4" – 16-7/8"
TA-38	Door, "J" style, 10-1/4" – 24-7/8"
TA-39	Door, "E" style, 10-1/4" - 31-7/8"
TA-40	Door, "BB3" style, 12-13/32" - 18", Right
TA-41	Door, "BB3" style, 12-13/32" - 18", Left
TA-42	Door, "UB" style, 12-13/32" - 22-1/4", Right
TA-43	Door, "UB" style, 12-13/32" - 22-1/4", Left
TA-44	Door, "BB" style, 12-13/32" - 28-1/4", Right
TA-45	Door, "BB" style, 12-13/32" - 28-1/4", Left
TA-999A	1253 door seal, 16-1/8"
TA-999B	1252 door seal, 26-3/8"
TA-999C	1151 door seal, 20-3/8"

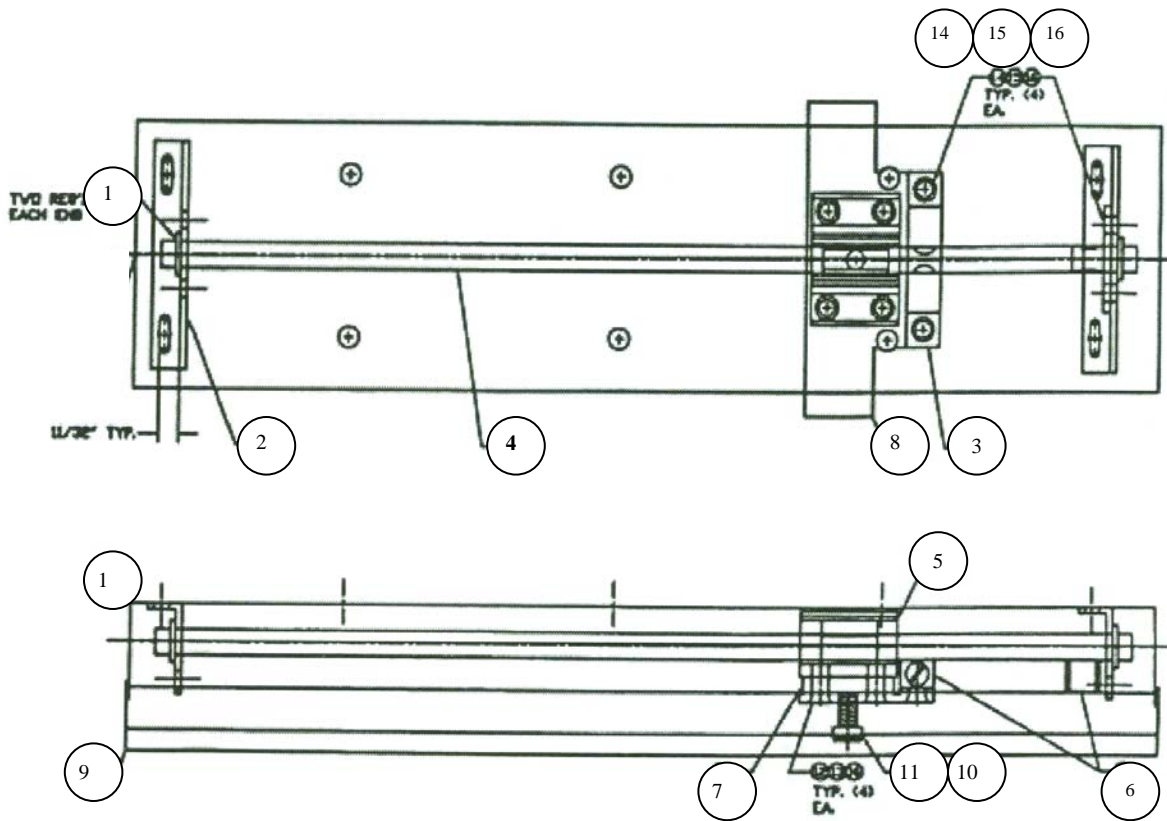

**UNTRACK ASSEMBLY**  
P/N 201403

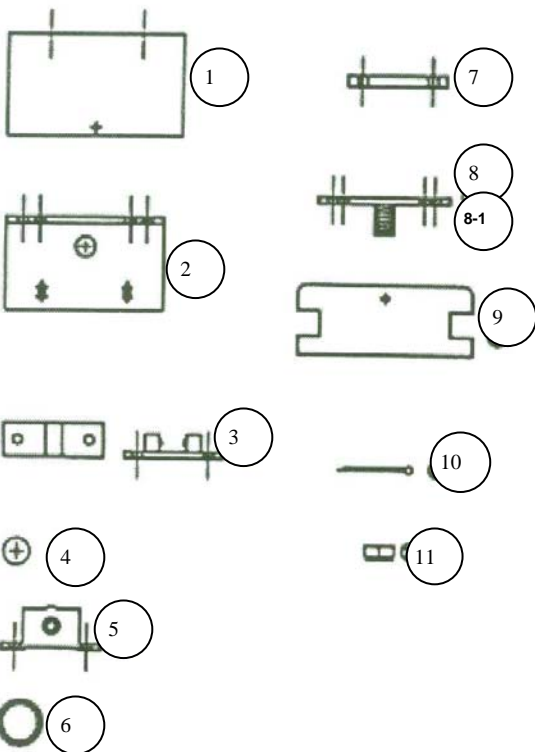

ITEM	PART NO.	DESCRIPTION
1	201392	BASE, UNTRACK
2	201394	BRACKET, UNTRACK SHAFT
3	201400	CATCH, UNTRACK DOOR
4	201395	SHAFT, UNTRACK
5	201398	BEARING, UNTRACK
6	201399	SNAP RING, UNTRACK
7	201396	SPACER, UNTRACK BEARING
8	201397	PLATE, BEARING UNTRACK
8-1	201401	STUD, UNTRACK BEARING PLATE
9	201393	COVER, UNTRACK
10	TA-36L	KEY, COTTER
11	TA-36M	NUT, CASILATED 1/4 - 20 S.S.
12	TA - 348	SCREW, 6-32X3/4" LG. PH. HD. SS
13	0386500	WASHER, SPLIT RING #8
14	TA - 8B	SCREW, 6-32X3/8" LG. PH. HD. SS
15	TA - 7	WASHER, LOCK #8
16	0223400	NUT, 6-32 HEX
17	313028	SCREW, 10-24X3/8" (NOT SHOWN)
18	313021	SCREW, 10-24X5/8" (NOT SHOWN)
19	TA-36H	ARM, UNI-DOOR (NOT SHOWN)
20	201167	BRKT., DOOR ARM (NOT SHOWN)

---

***THERMOTAINER DOOR STYLES***

**“C” Style Drop type Doors – Part # TA-37 – 10-1/4” x 16-7/8”**

**Model #'s:**

1201	1202	1203	1204	1301	1302
1303	1304	1305	1306	1308	1309
1601	1602	1603	2201	2202	2203
2204	2302	2303	2304	2306	2308
2309	2314	2316	2318	2602	2603

**“J” Style Drop type Doors – Part # TA-38 – 10-1/4” x 24-1/8”**

**Model #'s:**

1101	1102	1103	1104	1452	1453
1454	1455	1456	1458	1651	1652
1653	2101	2102	2103	2104	2452
2453	2454	2456	2458	2464	2466
2468	2652	2653			

**“E” Style Drop Type Doors – Part # TA-39 – 10-1/4” x 31-7/8”**

**Model #'s:**

1351	1352	1353	2352	2353	
------	------	------	------	------	--

**“BB3” Style French Doors – Part # TA-40 – Right Door – 12-13/32” x 18”  
Part # TA-41 – Left Door – 12-13/32” x 18”**

**Model #'s:**

1253	1262	1571	1572	1573	1574
------	------	------	------	------	------

**“UB” Style French Doors – Part # TA-42 – Right Door – 12-13/32” x 22-1/4”  
Part # TA-43 – Left Door – 12-13/32” x 22 1/4”**

**Model #'s:**

1151	1152	1153	1154	1551	1552
1553	1554				

---

## Thermotainer Angle Slides

<b>Model</b>	<b>Part#</b>	<b>Size</b>	<b># of Slides per Model</b>
1101	201068	5" x 25-3/4"	8
1102	201068	5" x 25-3/4"	16
1103	201068	5" x 25-3/4"	24
1104	201068	5" x 25-3/4"	32
1151	201068	5" x 25-3/4"	8
1152	201068	5" x 25-3/4"	16
1153	201068	5" x 25-3/4"	24
1154	201068	5" x 25-3/4"	32
1201	201069	3" x 22-3/4"	8
1202	201069	3" x 22-3/4"	16
1203	201069	3" x 22-3/4"	24
1204	201069	3" x 22-3/4"	32
1253	201070	5" x 29-3/4"	18
1262	201068	5" x 25-3/4"	12
1301	201069	3" x 22-3/4"	4
1302	201069	3" x 22-3/4"	8
1303	201069	3" x 22-3/4"	12
1304	201069	3" x 22-3/4"	16
1305	201069	3" x 22-3/4"	20
1306	201069	3" x 22-3/4"	24
1308	201069	3" x 22-3/4"	32
1309	201069	3" x 22-3/4"	36
1351	201069	3" x 22-3/4"	8
1352	201069	3" x 22-3/4"	16
1353	201069	3" x 22-3/4"	24
1452	201068	5" x 25-3/4"	8
1453	201068	5" x 25-3/4"	12
1454	201068	5" x 25-3/4"	16
1455	201068	5" x 25-3/4"	20
1456	201068	5" x 25-3/4"	24
1458	201068	5" x 25-3/4"	32
1551	201068	5" x 25-3/4"	8
1552	201068	5" x 25-3/4"	16

---

## Thermotainer Angle Slides

<b>Model</b>	<b>Part#</b>	<b>Size</b>	<b># of Slides per Model</b>
1553	201068	5" x 25-3/4"	24
1554	201068	5" x 25-3/4"	32
1571	201068	5" x 25-3/4"	6
1572	201068	5" x 25-3/4"	12
1573	201068	5" x 25-3/4"	18
1574	201068	5" x 25-3/4"	24
1601	201069	3" x 22-3/4"	4
1602	201069	3" x 22-3/4"	8
1603	201069	3" x 22-3/4"	12
1651	201068	5" x 25-3/4"	4
1652	201068	5" x 25-3/4"	8
1653	201068	5" x 25-3/4"	12
2101	201068	5" x 25-3/4"	8
2102	201068	5" x 25-3/4"	16
2103	201068	5" x 25-3/4"	24
2104	201068	5" x 25-3/4"	32
2201	201069	3" x 22-3/4"	8
2202	201069	3" x 22-3/4"	16
2203	201069	3" x 22-3/4"	24
2204	201069	3" x 22-3/4"	32
2302	201069	3" x 22-3/4"	8
2303	201069	3" x 22-3/4"	12
2304	201069	3" x 22-3/4"	16
2306	201069	3" x 22-3/4"	24
2308	201069	3" x 22-3/4"	32
2309	201069	3" x 22-3/4"	36
2314	201069	3" x 22-3/4"	16
2316	201069	3" x 22-3/4"	24
2318	201069	3" x 22-3/4"	32
2352	201069	3" x 22-3/4"	16
2353	201069	3" x 22-3/4"	24
2452	201068	5" x 25-3/4"	8
2453	201068	5" x 25-3/4"	12
2454	201068	5" x 25-3/4"	16
2456	201068	5" x 25-3/4"	24
2458	201068	5" x 25-3/4"	32
2464	201068	5" x 25-3/4"	16
2466	201068	5" x 25-3/4"	24
2468	201068	5" x 25-3/4"	32
2602	201069	3" x 22-3/4"	8
2603	201069	3" x 22-3/4"	12
2652	201068	5" x 25-3/4"	8
2653	201068	5" x 25-3/4"	12

## Number of Heating Elements per Unit

Model	Watts	Heating Elements	Model	Watts	Heating Elements
1101	1500	2 @ 750 watts	1574	4000	8@500 watts
1102	2000	2@750watts/1 /1 @ 500 watts	1601	750	2@375 watts
1103	2500	2 @ 750 watts/2 @ 500 watts	1602	1125	3@375 watts
1104	3000	3 @ 750 watts/2 @ 375 watts	1603	1500	4@375 watts
1151	1500	2 @ 750 watts	1651	1000	2@500 watts
1152	3000	4 @ 750 watts	1652	1500	3@500 watts
1153	4500	6 @ 750 watts	1653	2000	4@500 watts
1154	6000	8 @ 750 watts	2101	1500	4@375 watts
1201	1000	2 @ 500 watts	2102	3000	8@375 watts
1202	1500	3 @ 500 watts	2103	4500	12@ 375 watts
1203	2000	4@500 watts	2104	6000	16@375 watts
1204	2500	5 @ 500 watts	2201	1500	4@375 watts
1253	3000	6 @ 500 watts	2202	3000	8@375 watts
1262	2000	4 @ 500 watts	2203	4500	12@ 375 watts
1301	750	2 @ 375 watts	2204	6000	16@ 375 watts
1302	1000	2 @ 500 watts	2302	1500	4@375 watts
1303	1500	2 @ 750 watts	2303	2250	6@375 watts
1304	1500	3 @ 500 watts	2304	3000	8@375 watts
1305	2500	2 @ 750 watts/2 @ 500 watts	2306	4500	12@ 375 watts
1306	2250	3 @ 750 watts	2308	6000	16@375 watts
1308	3000	3@1000 watts	2309	6750	18@375 watts
1309	3000	4 @ 750 watts	2314	3000	8@375 watts
1351	1000	2 @ 500 watts	2316	4500	12@ 375 watts
1352	1500	2 @ 750 watts	2318	6000	16@375 watts
1353	2000	2 @ 1000 watts	2352	2000	4@500 watts
1452	1500	2 @ 750 watts	2353	3000	<a href="#">6@500</a> watts
1453	2000	2 @ 1000 watts	2452	1500	<a href="#">4@375</a> watts
1454	2000	2 @ 750 watts /1 @ 500 watts	2453	2250	6@375 watts
1455	3500	2 @ 1000 watts/2 @ 750 watts	2454	3000	8@375 watts
1456	2750	2 @1000 watts/1 @ 750 watts	2456	4500	12@ 375 watts
1458	3000	3 @ 1000 watts	2458	6000	16@ 375 watts
1551	1500	2 @ 750 watts	2464	3000	8@375 watts
1552	3000	4 @ 750 watts	2466	4500	12@375 watts
1553	4500	6@750 watts	2468	6000	16@375 watts
1554	6000	8@750 watts	2602	1500	4@375 watts
1571	1000	2@500 watts	2603	2250	6@375 watts
1572	2000	4@500 watts	2652	1500	4@375 watts
1573	3000	6@500 watts	2653	2250	6@375 watts