

ER136 & ER236

**IMPORTANT SAFETY INSTRUCTIONS
SAVE THESE INSTRUCTIONS**

**DANGER
TO REDUCE THE RISK OF FIRE OR ELECTRIC SHOCK, CAREFULLY FOLLOW
THESE INSTRUCTIONS.**

TABLE OF CONTENTS

<u>SECTION « A » DESCRIPTION</u>	<u>PAGE</u>
Installation and maintenance manual	A1
Construction	A2
Shipping	A2
Warnings	A3
Distances to respect	A4
Installation	A4
Retarder/proofer operations	A5
Timer programming instructions	A6
Example of timer adjustments	A7
Humidity control instructions.	A8
Troubleshooting	A9
Maintenance and cleaning	A10
For more information, please contact our office:	A12
 <u>SECTION « B » DIMENSIONS</u>	
ER136 FRONT.	B1
ER136 SIDE.	B2
ER136 TOP.	B3
ER236 FRONT.	B4
ER236 SIDE.	B5
ER236 TOP.	B6
 <u>SECTION « E » COMPONENT PARTS</u>	
ER136 & ER236	E1
ER136	E3
ER236	E5
 <u>SECTION « F » CONTROL PANELS</u>	
ER136 120V/208V/1PH & 120V/240V/1PH	F1
ER136 220V/1PH/50 Hz	F3
ER236 120V/208V/1PH & 120V/240V/1PH.	F5
ER236 220V/1PH/50HZ.	F7

SECTION « G » ELECTRIC SCHEMATICS

ER136 - 120V/208V/1PH & 120V/240V/1PH	G1
ER136 - 220V/1PH/50HZ	G2
ER236 - 120V/208V/1PH & 120V/240V/1PH	G3

Warranty

FAM-ER-A.DOC

REV. 25/05/05

INSTALLATION AND MAINTENANCE MANUAL

The manufacturer suggests to read this manual carefully.

This retarder/proofer is manufactured with first quality material by experienced technicians. Proper installation and maintenance will guarantee a reliable service for years to come.

A nameplate fixed to the front of the retarder/proofer specifies the serial number, model number, number of phase, amperage, voltage and frequency.

Drawings, electrical diagram and replacement part numbers are included in this manual. The electrical diagram is affixed in the control panel located on the top of the retarder/proofer.

ATTENTION

DOYON is not responsible for damages to the property or the equipment caused by personnel who is not certified by known organizations. The customer is responsible for finding qualified technicians in electricity and plumbing for the installation of the oven.

CONSTRUCTION

You just bought the most advanced retarder/proofer in the world, the "DOYON" technology at its best. This retarder/proofer is manufactured using the highest quality components and material.

The DOYON equipments are designed with parts that are easy to find.

SHIPPING

For your safety, this equipment is verified by qualified technicians and carefully crated before shipment. The freight company assumes full responsibility concerning the delivery in good condition of the equipment in accepting to transport it.

IMPORTANT

RECEPTION OF THE MERCHANDISE

Take care to verify that the received equipment is not damaged before signing the delivery receipt. If a damage or a lost part is noticed, write it clearly on the receipt. If it is noticed after carrier left, contact immediately the freight company in order that they do their inspection.

We do not assume the responsibility for damages or losses that may occur during transportation.

WARNINGS

FOR YOUR SAFETY

**DO NOT STORE OR USE GASOLINE OR OTHER FLAMMABLE VAPORS
AND LIQUIDS IN THE VICINITY OF THIS OR ANY APPLIANCE.**

IMPORTANT

INSTALLATION AND SERVICE

Installation and service must be done by specialized technicians. Contact a certified electrician and plumber for set up.

The proofer must be connected to the utility and electrically grounded in conformity to the effective local regulations. If these are not established, the oven must be connected according to the Canadian Electrical Code (CSA-C22.1-XX) or National Electrical Code (NFPA 70-XX). Refer to last edition year for XX.

DISTANCES TO RESPECT

- Top of the retarder/proofer : a clearance of 24 inches to the ceiling must exist to permit maintenance.
- Back and sides of the retarder/proofer : 4 inches.

INSTALLATION

IN GENERAL

Take off the packaging material with care. Take off all the material used for packing and accessories.

Each unit is set up to be used with the electrical supply specified on the nameplate fixed on the front of the unit.

1. To the electrician

Electrical supply installation must be in accordance with the electrical rating on the nameplate.

2. To the plumber

This equipment is to be installed to comply with the applicable federal, state or local plumbing codes.

Connect the steam system (1/4 NPT) to the water distribution network.

We highly recommend to use a water softener to eliminate minerals in the water. We suggest you to use CUNO # CFS6135 (Doyon part number PLF240).

WARNING

Do not adjust the needle valves, it has been done at the factory.

RETARDER/PROOFER OPERATION

1. **Program** the **timer control before turning on the main switch**. (See page A6 Programming instructions).

2. Turn the power switch **0/1** to the **"1"** position.

3. Select  for manual proofer or  for auto retarder/proofer.

4.

"" In this position, it is on proofer mode (See page A8 Humidity control instructions). The unit heats up to the settings of the humidity control (about 100°F / 37°C), and then the humidity increases up to the humidity settings (80% to 85% humidity). The refrigeration unit can not work at the same time as the proofer.

"" In this position, you can program how long the unit will work in the proofer mode and how long it will work in the refrigeration mode. Don't worry, both can not work at the same time. See timer programming instructions.

(See operating instructions for the timer setting and example on next pages).

TIMER STAGE:

Timer "ON" =

Timer "OFF" =



= STARTING time of proofer



STARTING time of refrigeration

NOTE: THE STARTING TIME OF PROOFER AUTOMATICALLY STOPS THE REFRIGERATION.



Button: Used for anticipating manually the starting time of the next program and vice versa.

5. Adjust the thermostat at the desired temperature (100°F / 37°C).

6. Adjust the humidity at the desired value (80%).

7. Adjust the refrigeration at the desired temperature.

We suggest you to turn off the light when the unit is used as a refrigerator, because the light heats. Then you will save energy.

8. Loading the proofer. When used on manual mode "  wait until the **"PREH"** on the humidity control disappears before loading.

Leave the product inside until it is ready to bake.

9. When proofing cycle is completed, turn the switch "OFF" or to . "AUTO" mode.

When the proofer is not in operation, open the doors to let out the humidity and then prevent mold.

P.S. The doors should not be opened unnecessarily to conserve the heat and humidity in the proofer.

TIMER PROGRAMMING INSTRUCTIONS (GRASSLIN)

The circular keypads are positioned to provide a sequential path for programming.

Starting with **Prog** to select a program and then **HAND**  to select heating (ON) or cooling (OFF). Then press **h** for hour, **m** for minute and finally **Day** to select day or days of the week.

If an input is missing or incomplete, the missing segments will flash when the  or **Prog** key is depressed. For example, if no "ON" or "OFF" is selected, the "ON" symbol will flash. The missing entry must be completed before programming can resume.

While programming, pressing the **h**, **m**, or **Day** key longer than 2 seconds will cause a rapid roll of the parameter.

A program consists of :

1. Press **Prog** key
2. Select "ON " or "OFF"
3. Set hour and minute
4. Set day or multiple days on which it is to occur



Note:

- The program have to be coherent. So it is recommended to use **Res** to reset the program before doing any important modification to the program in a way to avoid conflict between the different programs.
- A flashing display indicates either incomplete data entry or the battery is low (more than 5 days).
- The **±1h** key sets clock time up or down 1 hour for daylight savings time adjustment in the spring and fall.

SETTING TIME AND DAY OF CLOCK.

1. Select the cycle of 12:00 hours or 24 hours.

Depress and hold **h** key while pressing **±1h** key to toggle between one or the other cycle and from AM to PM.





2. **Press and hold down**  key.
3. If setting the time when daylight savings time is in effect, press **±1h** key once.
4. Set hour with **h** key and if AM or PM does not appear in display, it's a cycle of 24 hours.
5. Set minutes with **m** key.
6. Press **Day** key repeatedly to the day of the week (1 is Monday, 7 is Sunday).
7. **Release**  **key.**

EXAMPLE OF TIMER ADJUSTMENT

Monday to Saturday : proofer mode starts at 6:00 Am and stops at 8:00 Pm.
: retarder (fridge) mode starts at 8:00 Pm and stops at 6:00 Am.

Sunday : proofer mode starts at 7:00 Am and stops at 5:00Pm.
: retarder (fridge) mode starts at 5:00 Pm until next mode (proofer mode at 6:00 Am on Monday).

Note: On automatic mode, the proofer or the retarder is on. When the proofer stops, the retarder automatically starts.

- 1) The time and day should have been set before doing this example (see previous pages).
- 2) Press **PROG** twice, you should see FR=20. Press **CLOCK** to go back to the hour display. If you don't have FR=20, you should do a reset by pressing RES and return to #1. You have to do this to avoid the existing program to overlap the new program.
- 3) Press **PROG**, you should see 1234567, select the days of the week by pressing DAY until you get 123456.
- 4) Select the hour (6:00 Am) by pressing **H** (hour) and **M** (min).
- 5) Press the HAND until you get  on the bottom of the display.
- 6) Press **PROG**, you should see 1234567, select the days of the week by pressing DAY until you get 123456.
- 7) Select the hour (8:00 Pm) by pressing **H** (hour) and **M** (min).
- 8) Press the HAND until you get  on the bottom of the display.
- 9) Press **PROG**, you should see 1234567, select the days of the week by pressing DAY until you get 7.
- 10) Select the hour (7:00 am) by pressing **H** (hour) and **M** (min).
- 11) Press the HAND until you get  on the bottom of the display.
- 12) Press **PROG**, you should see 1234567, select the days of the week by pressing DAY until you get 7.
- 13) Select the hour (5:00 Pm) by pressing **H** (hour) and **M** (min).
- 14) Press the HAND until you get  on the bottom of the display.
- 15) Press **CLOCK**.



HUMIDITY CONTROL INSTRUCTIONS

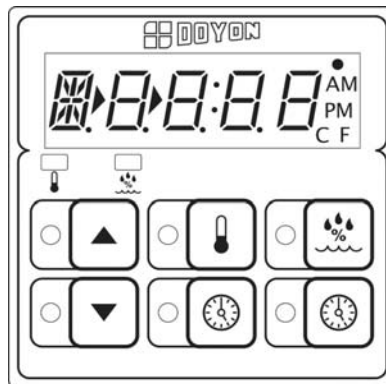

1. Turn the main switch **0/1** to " 1 ".
2. The light inside the proofer will turn ON and the digital control will indicate a code. Then, "PREH" will flash.



3. "PREH" will be displayed on the control until it reaches the set temperature.

To check and modify:

Temperature settings : Press and hold down for 2 seconds the “” temperature key on the humidity control and adjust with the UP and DOWN arrows. Then, press temperature key  “ to save data or “” to exit without saving.

Humidity settings : Press and hold down for 2 seconds the  humidity key and adjust with the UP and DOWN arrows. Then, press humidity key to save data or "red  " to exit without saving.

4. When the control reaches the set parameters, "PREH" will disappear and the timer display will appear.

To start the timer, press " green  ", the timer will stop blinking and start countdown.

At the end of the countdown an alarm will go off and " READY " will appear on the display.

Press " red  " to stop the alarm.

When the proofer is not in operation, open the doors to let out the humidity and prevent mould.

P.S. The doors should not be opened unnecessarily to conserve the heat and humidity in the proofer. The water pan under the proofer's doors should be cleaned daily.

POWER FAILURE

When the power comes back, the proofer will start automatically. It is recommended, when a power failure occurs, to turn off the unit in order to avoid it from starting without supervision.

TROUBLESHOOTING

BEFORE CALLING FOR SERVICE ANSWERS TO MOST FREQUENT QUESTIONS

Always cut off the main power before replacing any parts. Take care of water piping and electric cable.

Control parts on the front.

To remove parts from front panels, you have to go on the top of the unit.

Control panel, proofer unit and refrigeration units. They are located on the top.

Questions	Solutions
The unit does not turn on when installed.	Check if the light is on. Check if the proofer switch is on. Check the breaker of the building. Check the fuses on the front and in the electrical control panel.
The blower runs but the unit does not produce heat.	Make sure that the thermostat is adjusted to the desired temperature (over ambient temperature) and the pilot light is lit. Check the 30 A fuse in the electrical panel.
The blower runs but the unit does not produce steam.	Make sure that the humidity control is set at approximately 4. Verify if the water valve of the building is opened and if water goes into the proofer unit located on the top of the unit. Check if the water needle valve (of the unit) is opened between half to one turn. Just close it and open it one turn maximum. Verify the 15 A in the electrical panel.

UNIT MAINTENANCE AND CLEANING

Step by step	Recommendations
Clean the inside of the unit with water and soap.	We recommend and sell: Dirt Buster III : Action foam cleaner CHEMCO Part number : NEB201
Clean the unit exterior with a stainless steel polish.	We recommend and sell: Stainless steel cleaner SANY or CURTIS (comestible) Part number : NES201
Clean the windows with products like Brasso or equivalents. They are copper cleaners but good for this use.	We recommend and sell: Wright's: Cream copper cleaner J.A. Wright & Co. Part number : EXC300

MAINTENANCE: WATER COMPARTMENT

CLEAN WATER PAN REGULARLY: (3-6 MONTHS)

DISCONNECT THE MAIN POWER FROM THE UNIT:
UNSCREW AND REMOVE THE COVER OF THE STEAM UNIT. EMPTY THE
COMPARTMENT. CLEAR THE INSIDE, TAKE OUT THE MUD, SALT AND MINERALS
THAT CAN JAM THE LEVEL SWITCH. TAKE CARE NOT TO BREAK IT.

INSTALL A GOOD QUALITY WATER FILTER TO EXTEND LIFE OF THE STEAM
GENERATOR.

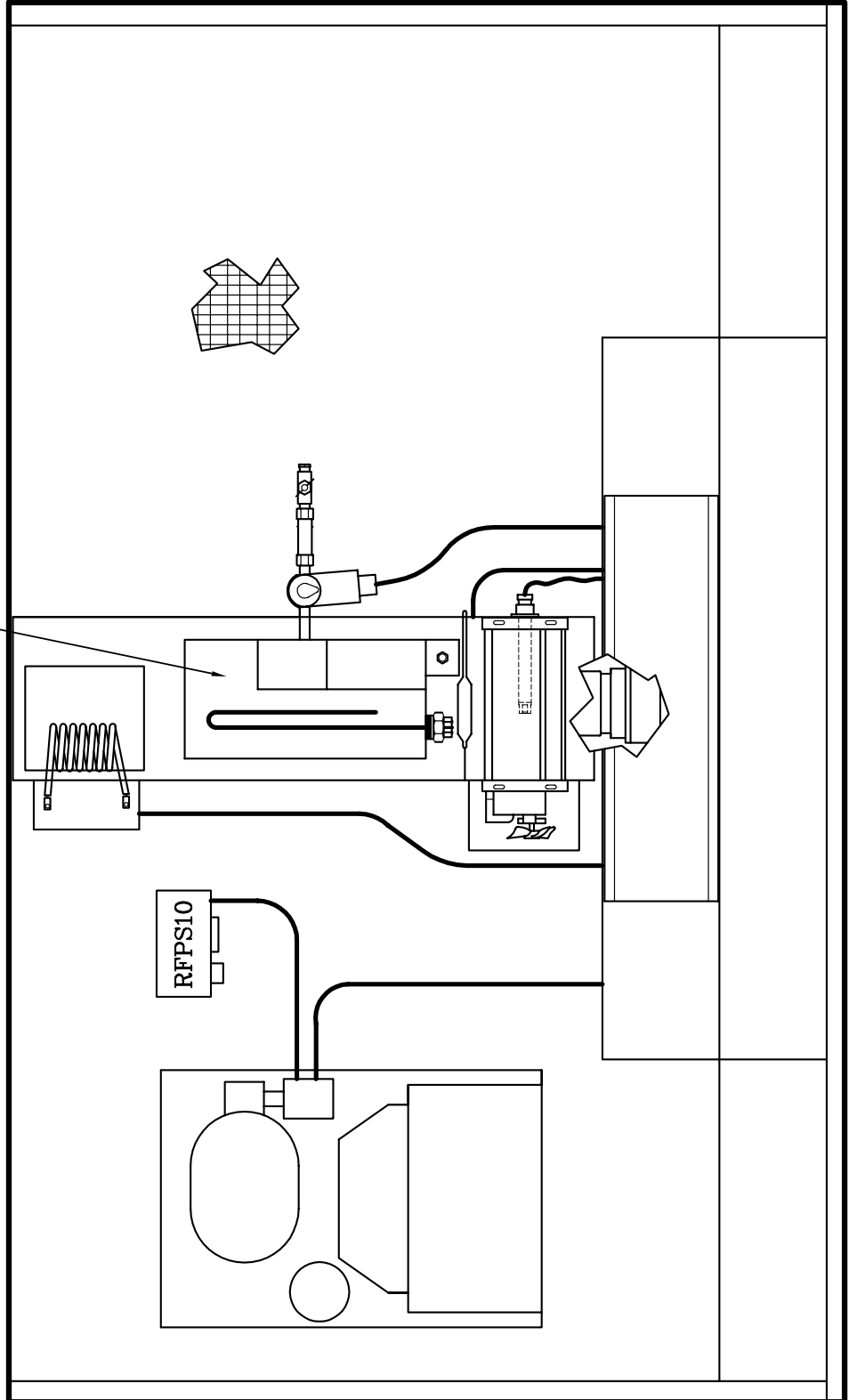

TOP

FOR MORE INFORMATION,
PLEASE CONTACT OUR OFFICE:

DOYON EQUIPMENT INC.
1255, rue Principale
Linière, Qc, Canada G0M 1J0

Tel. : 1 (418) 685-3431
Canada : 1 (800) 463-1636
U.S. : 1 (800) 463-4273
FAX : 1 (418) 685-3948

Internet: <http://www.doyon.qc.ca>
E-Mail : doyon@doyon.qc.ca

SECTION
B

DIMENSIONS

B1

ER136

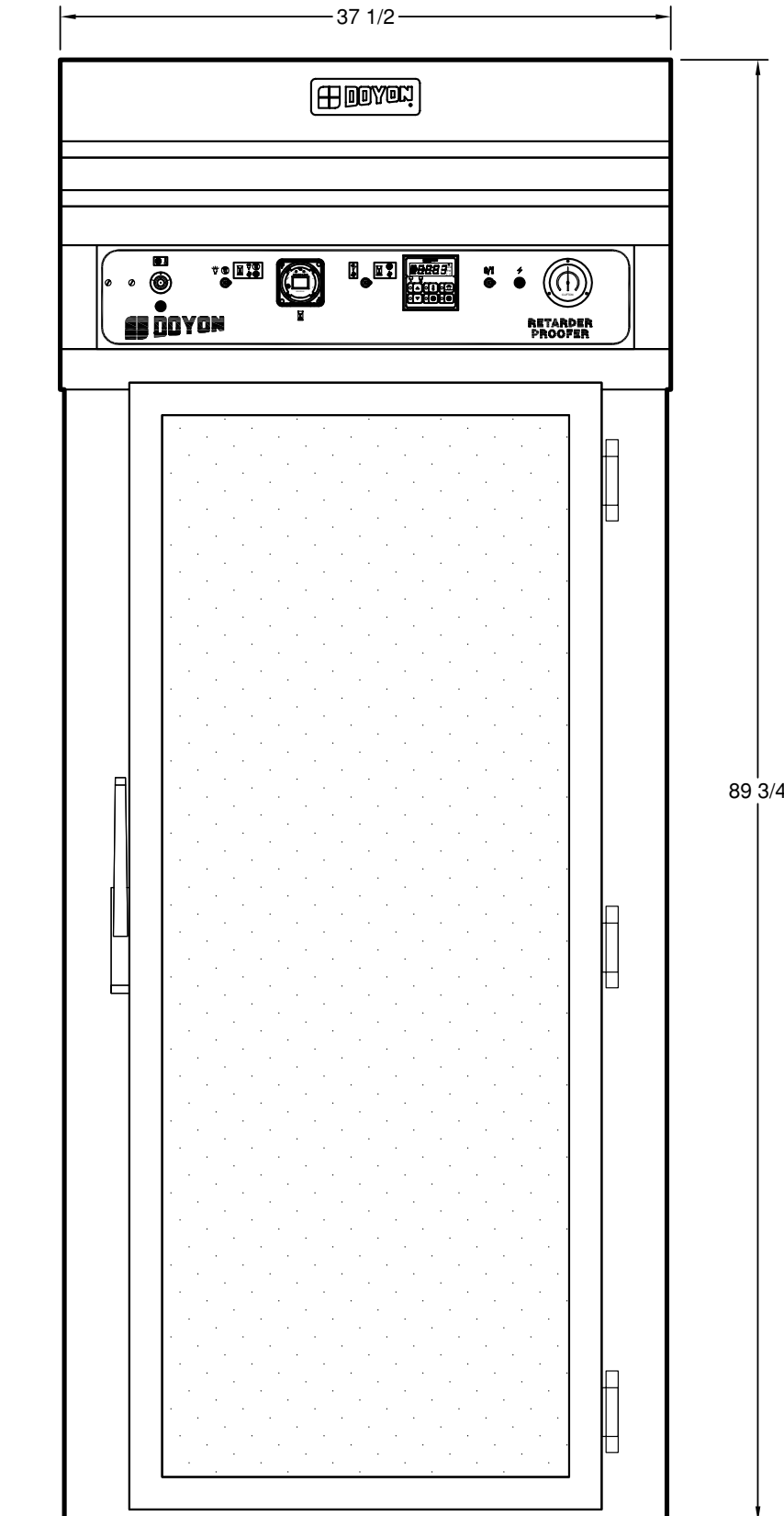

ER136

B2

ER136

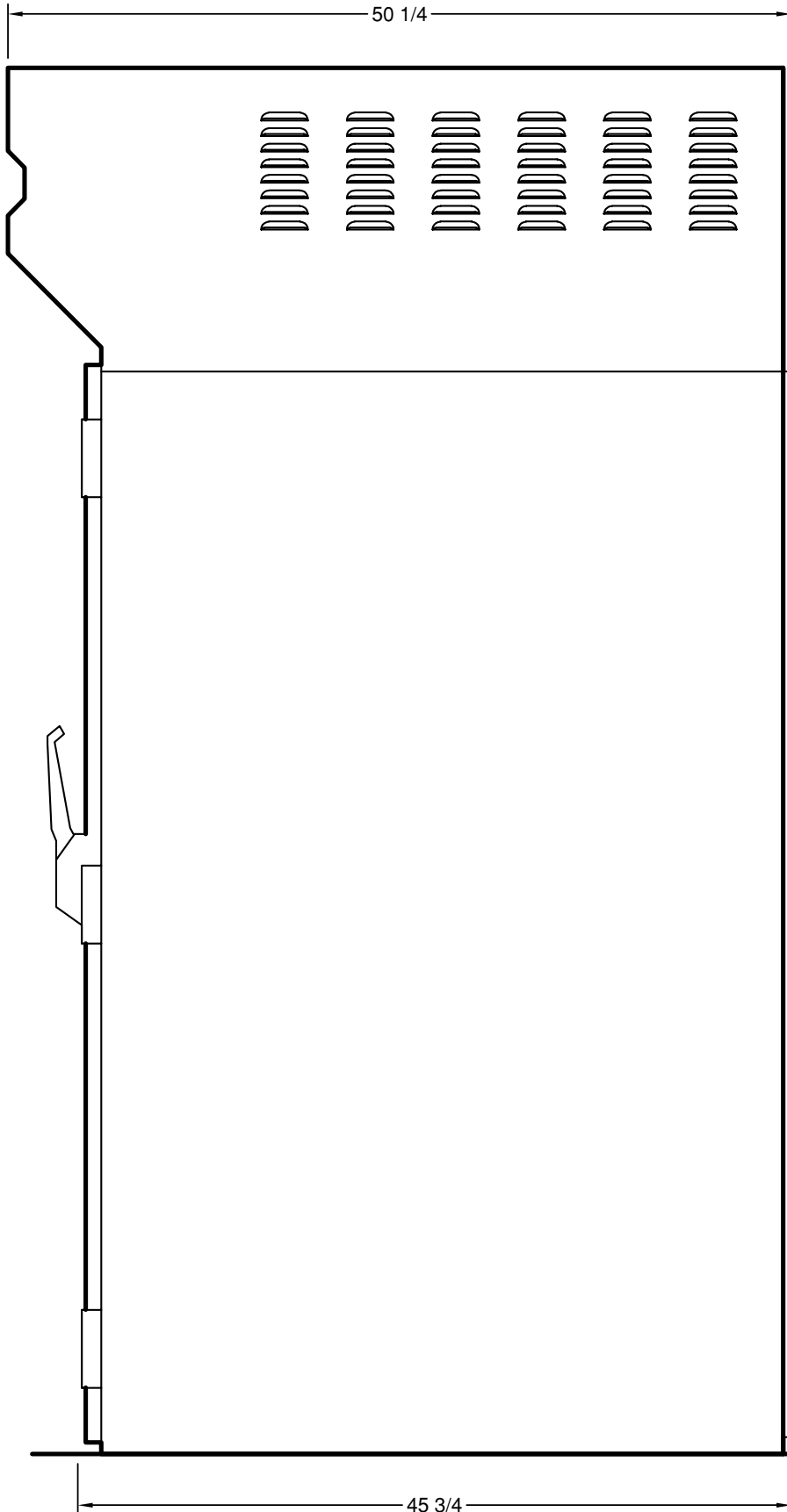

ER136

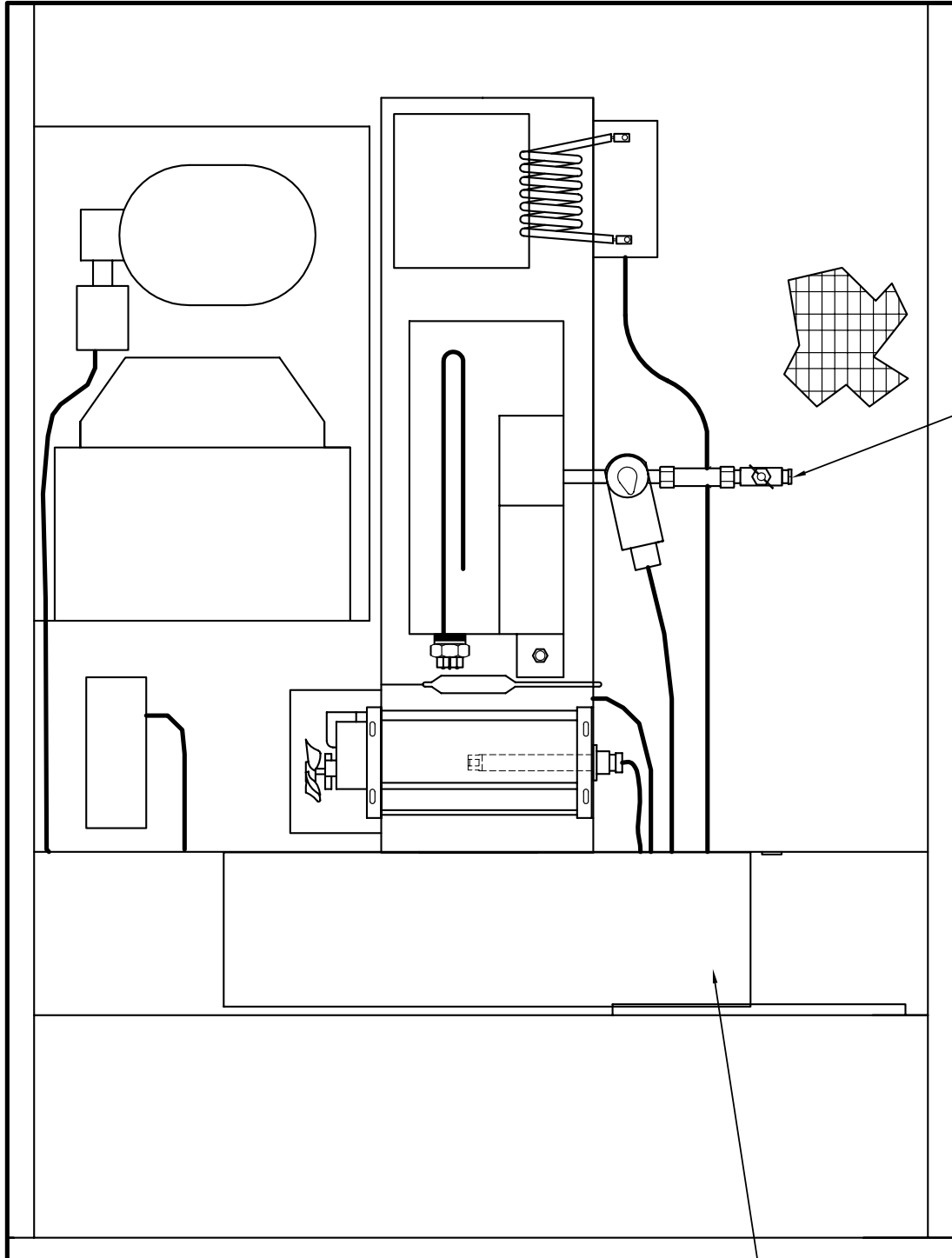

WATER INLET Ø1/4
ENTRÉE D'EAU Ø1/4

ELECTRICAL INLET
ENTRÉE ÉLECTRIQUE

ER236

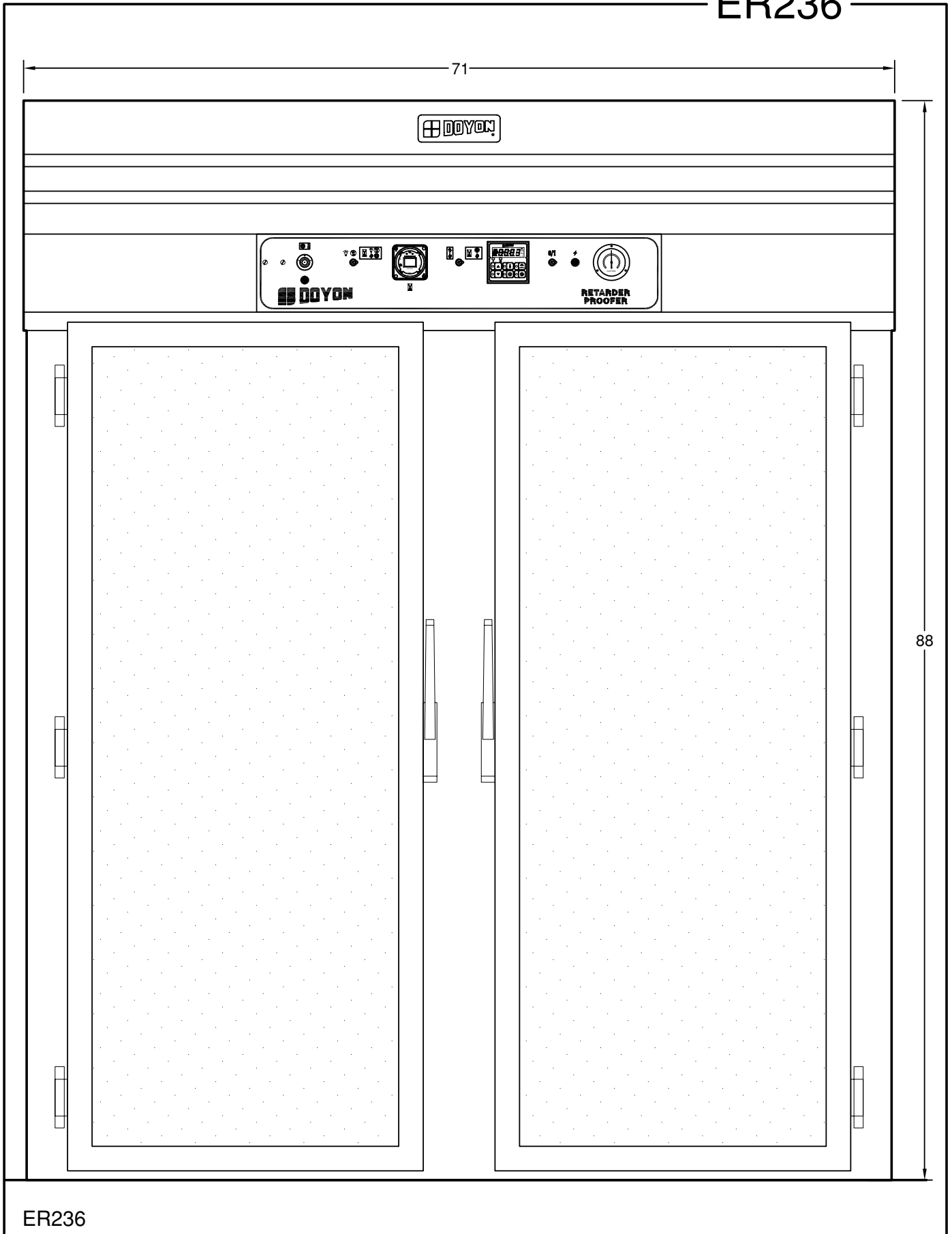

71

88

ER236

ER236

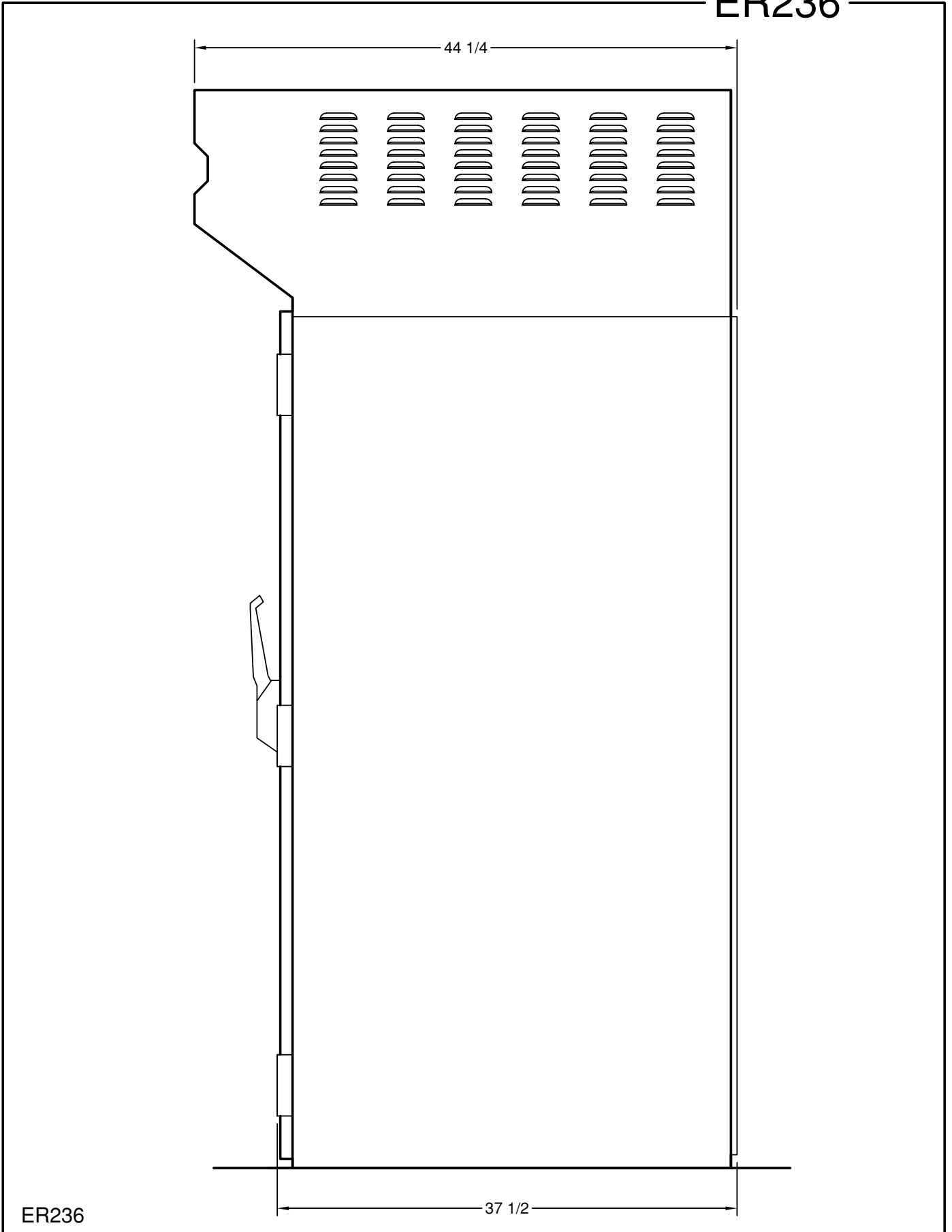

ER236

WATER INLET Ø1/4
ENTRÉE D'EAU Ø1/4

ELECTRICAL INLET
ENTRÉE ÉLECTRIQUE

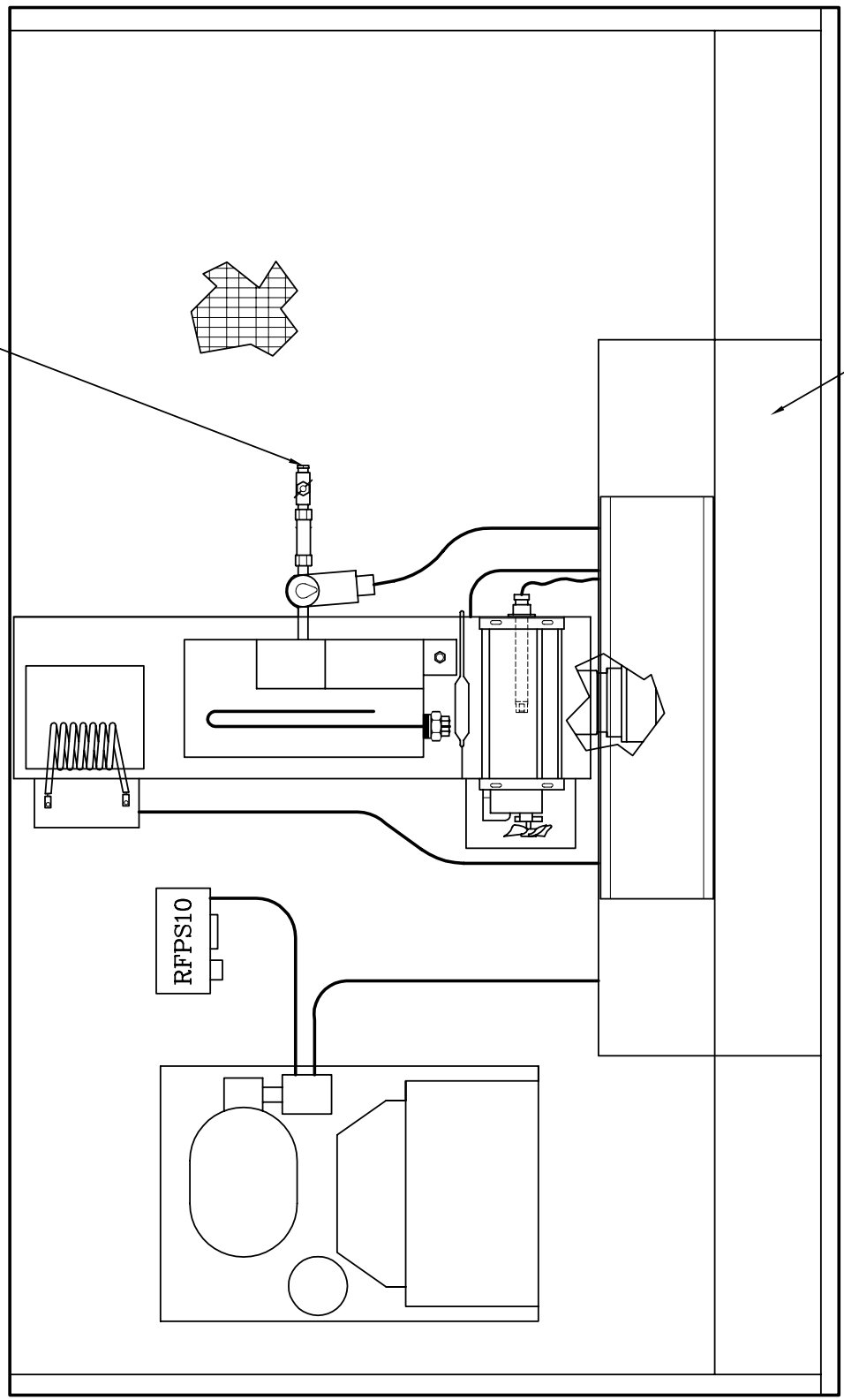

WATER INLET Ø1/4
ENTRÉE D'EAU Ø1/4

ELECTRICAL INLET
ENTRÉE ÉLECTRIQUE

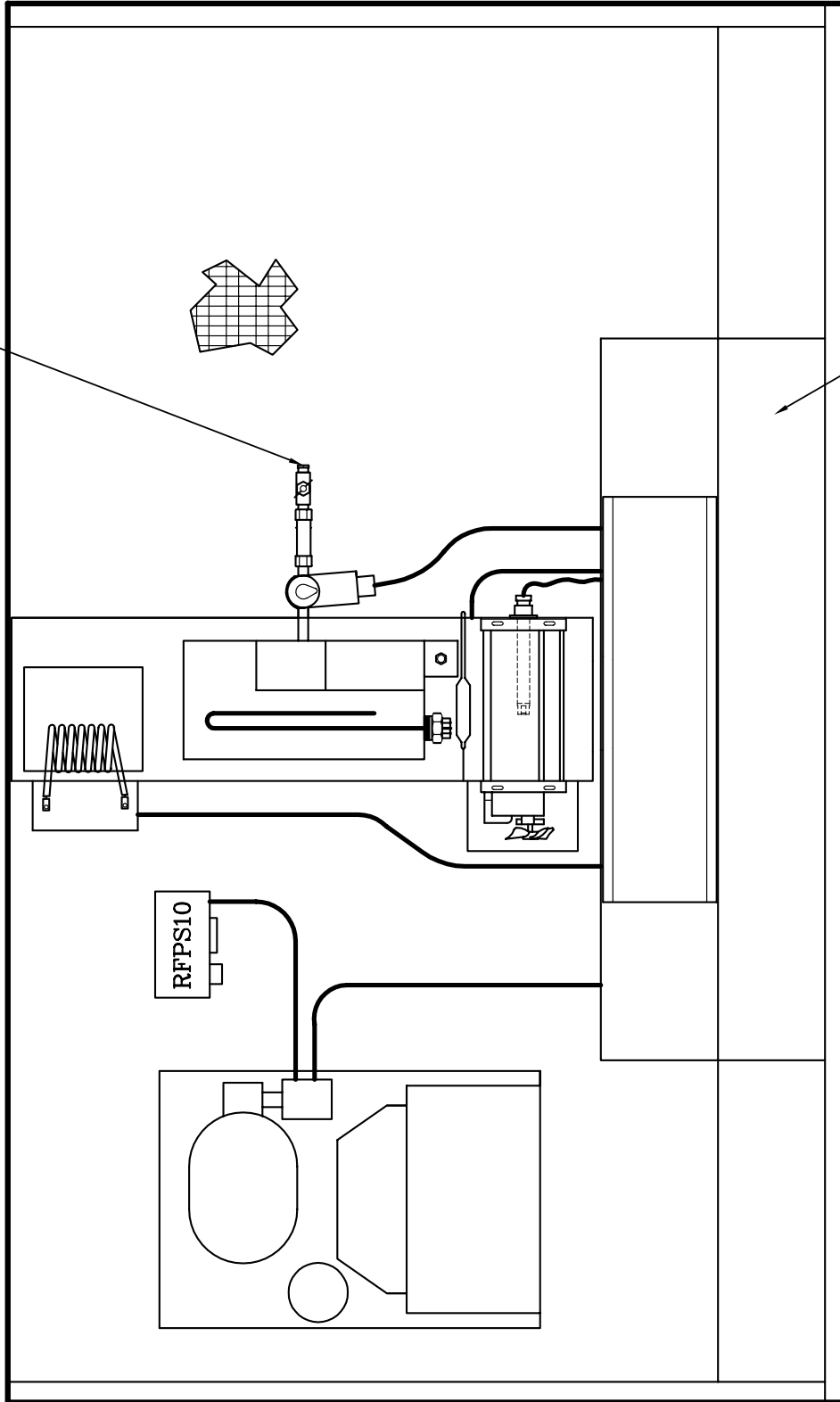

SECTION
E

COMPONENT PARTS

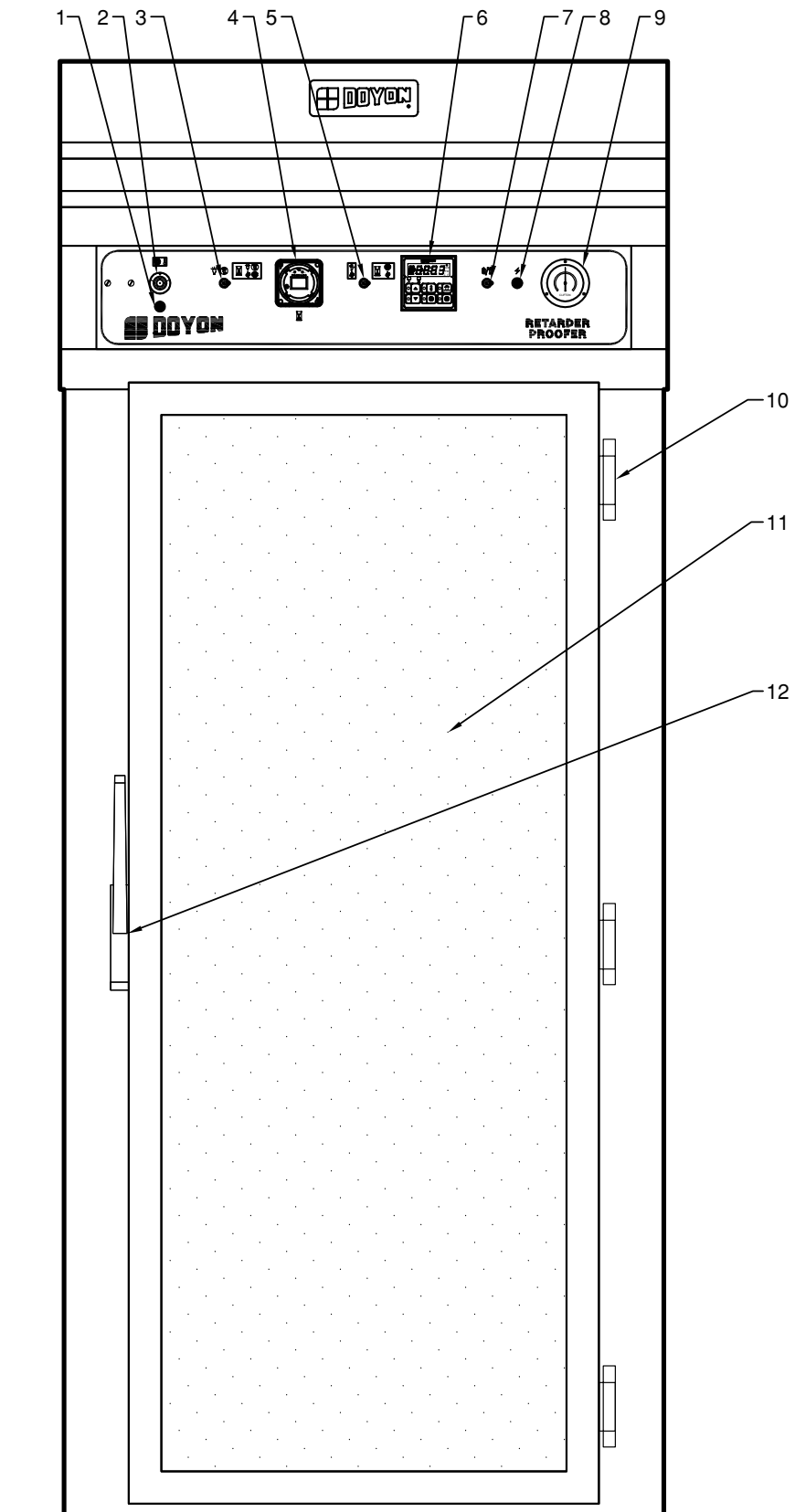

E2

Item	Part Number	Description	Quantity
1	ELL650	RED PILOT LIGHT	1
2	RFTH10	THERMOSTAT #A19 ABC-24	1
3	ELI655	SWITCH SPDT 20A	1
4	ELM680	ELECTRONIC TIME SWITCH 1 CHANEL	1
5	ELI650	TOGGLE SWITCH SPST 20A	1
6	ELT540	ELECTRONIC RELATIVE HUMIDITY CONTROL	1
AND	ELT541	PROBE FOR ELT540	1
AND	ELT542	DECAL FOR ELT540	1
7	ELI640	SWITCH DPST BP9	1
8	ELB096	5A BREAKER	1
9	RFTH05	THERMOMETER -40 TO 120°F	1
10	QUP320	DOOR HINGE	3
11	P2969R	PROOFER RETARDER DOOR	1
12	QUP500	LATCH	1

Model : ER136

View : FRONT

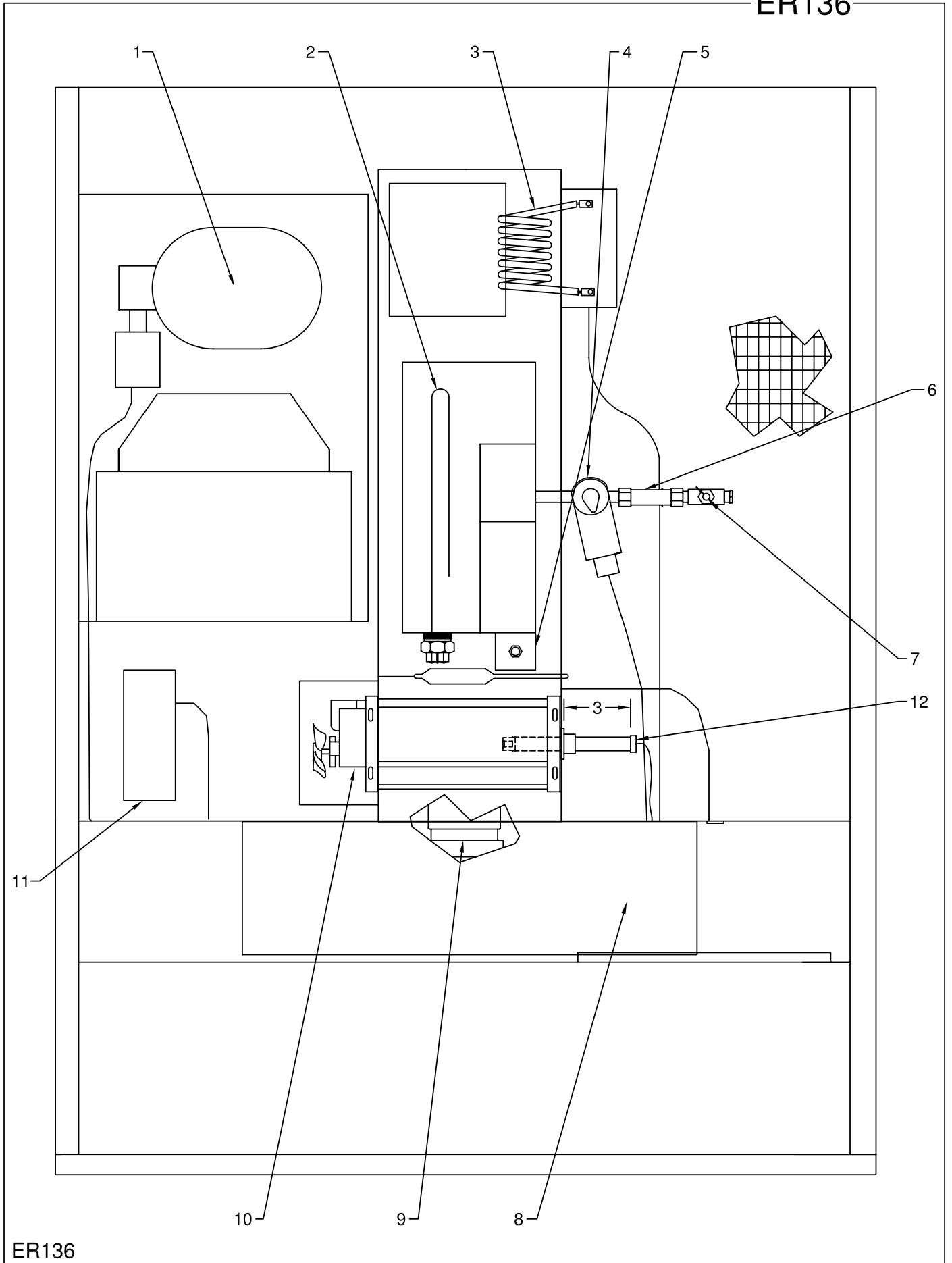

Item	Part Number	Description	Quantity
1	RFC010	REFRIGERATION UNIT 1/3 HP	1
2	ELE166	IMMERSION ELEMENT 208V 1500W	1
OR	ELE167	IMMERSION ELEMENT 240V 1500W	1
3	ELE133	COIL ELEMENT 208V 4000W	1
OR	ELE134	COIL ELEMENT 240V 4000W	1
4	ELS880	SOLENOID VALVE 110/120V 50/60Hz	1
5	QUF350	ELECTRIC FLOAT	1
6	PLF100	WATER FILTER	1
7	ELV590	NEEDLE VALVE	1
8	P240SER1	ER136 CONTROL PANEL 208V OR 240V 1 PH(SEE F1) 1	1
OR	P220SER1	ER136 CONTROL PANEL 220V 1 PH(SEE F3)	1
9	ELF660	VAPOR TYPE FIXTURE	1
AND	ELF650	PLASTIC BULB PROTECTOR	1
10	ELM731	MOTOR BLOWER 115 CFM	1
11	RFPS10	DUAL PRESSURE CONTROL	1
12	ELT541	PROBE FOR ELT540	1

Model : ER136

View : TOP

ER236

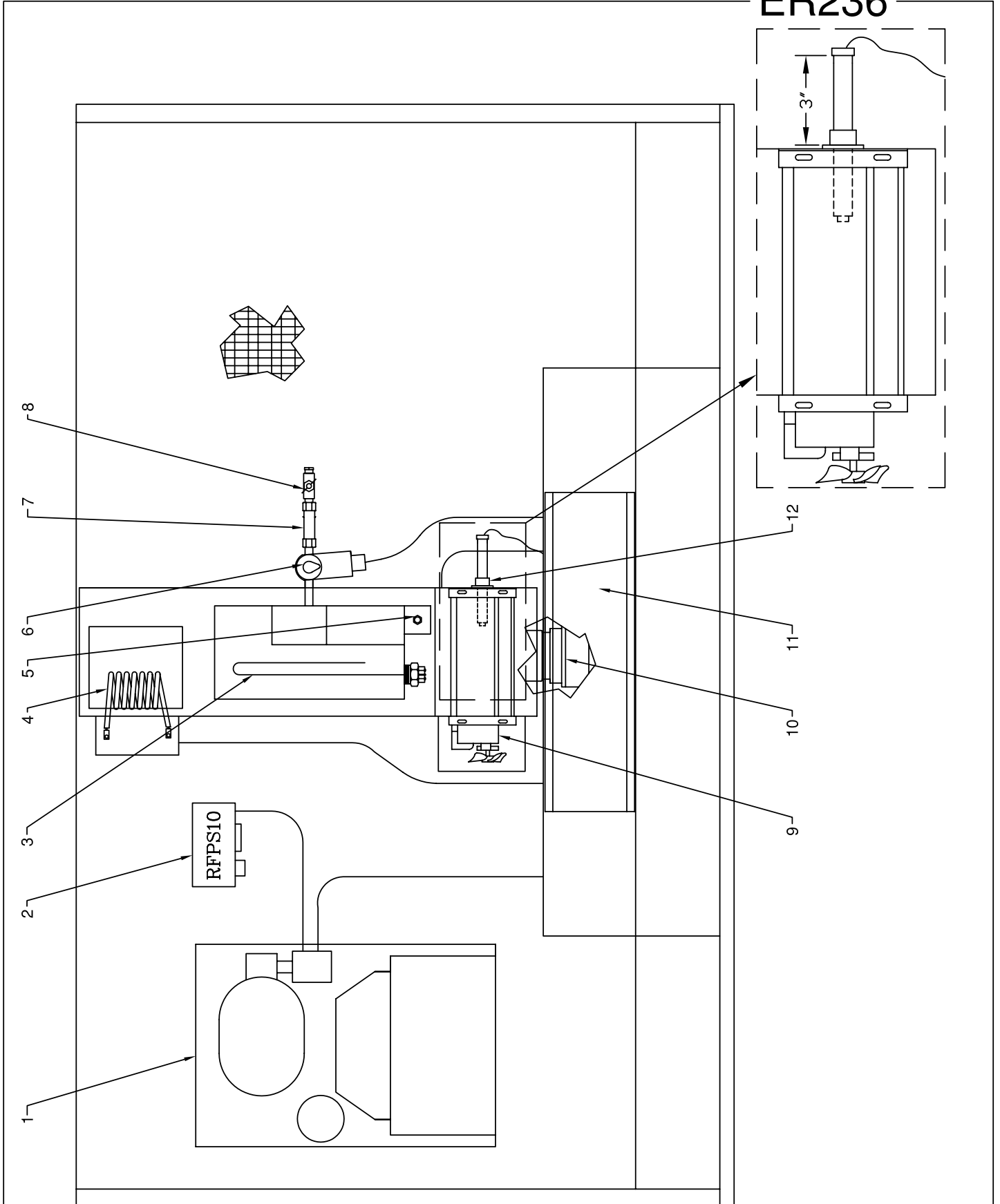

Item	Part Number	Description	Quantity
1	RFC020	REFRIGERATION UNIT 1/2Hp	1
2	RFPS10	DUAL PRESSURE CONTROL	1
3	ELE168	IMMERSION ELEMENT 240V 3000W	1
OR	ELE169	IMMERSION ELEMENT 208V 3000W	1
4	ELE134	COIL ELEMENT 240V 4000W	1
OR	ELE133	COIL ELEMENT 208V 4000W	1
5	QUF350	ELECTRIC FLOAT	1
6	ELS880	SOLENOID VALVE 110/120V 50/60Hz	1
7	PLF100	WATER FILTER	1
8	ELV590	NEEDLE VALVE	1
9	ELM731	MOTOR BLOWER 115 CFM	1
10	ELF660	VAPOR TYPE FIXTURE	1
AND	ELF650	PLASTIC BULB PROTECTOR	1
AND	ELA275	BULB 60W 130V	1
11	P240SER2	ER236 CONTROL PANEL 208V OR 240V 1 PH (SEE F5)	1
OR	P220SER2	ER236 CONTROL PANEL 220V 1 PH (SEE F7)	1
12	ELT541	PROBE FOR ELT540	1

Model : ER236

View : TOP

SECTION
F

CONTROL PANELS

ER136 208 OR 240 VOLTS 1 PH

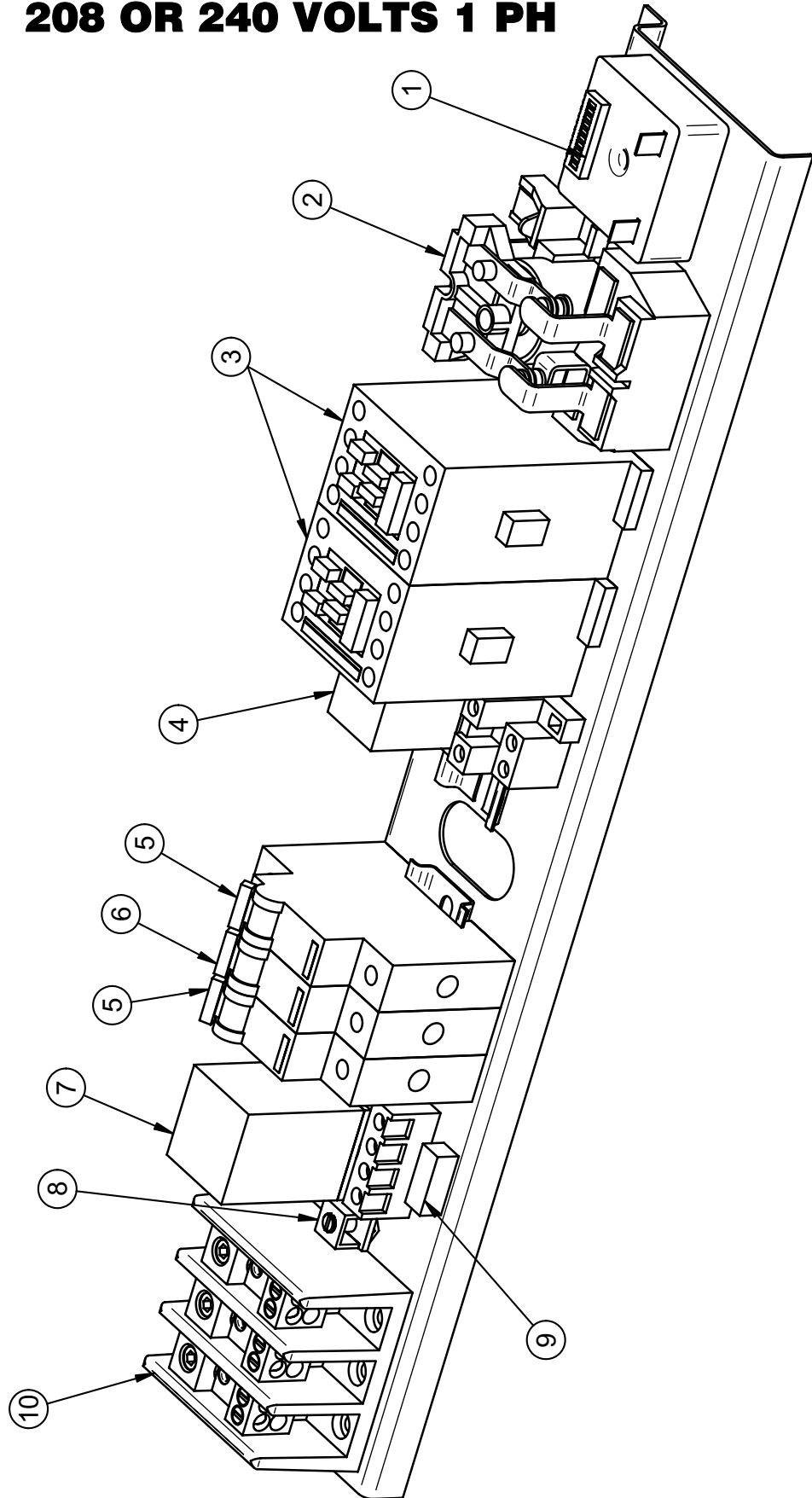

Item	Part Number	Description	Quantity
1	ELM735	SOLID STATE TIMER ICM FOR CH460,JAOP3G, FC2G AND E233	1
2	ELC650	RELAY 2P 30A 120VAC	1
3	ELC908	HEATING CONTACTOR	2
4	ELC630	CONTROL RELAY 12A COIL 120V	1
AND	ELC640	CONTROL RELAY BASE	1
5	ELB107	15A BREAKER	2
6	ELB109	30A BREAKER	1
7	ELC615	RELAY 10A 2P COIL 110V	1
AND	ELC617	BASE	1
8	ELL050	GROUND LUG	1
9	ELM736	LOAD FOR TIMER	1
10	ELB072	TERMINAL BLOCK 3P 175A	1

Model : 240V 1PH ER136 (P240SER1)

View : TOP

ER136 220 VOLTS 1 PH

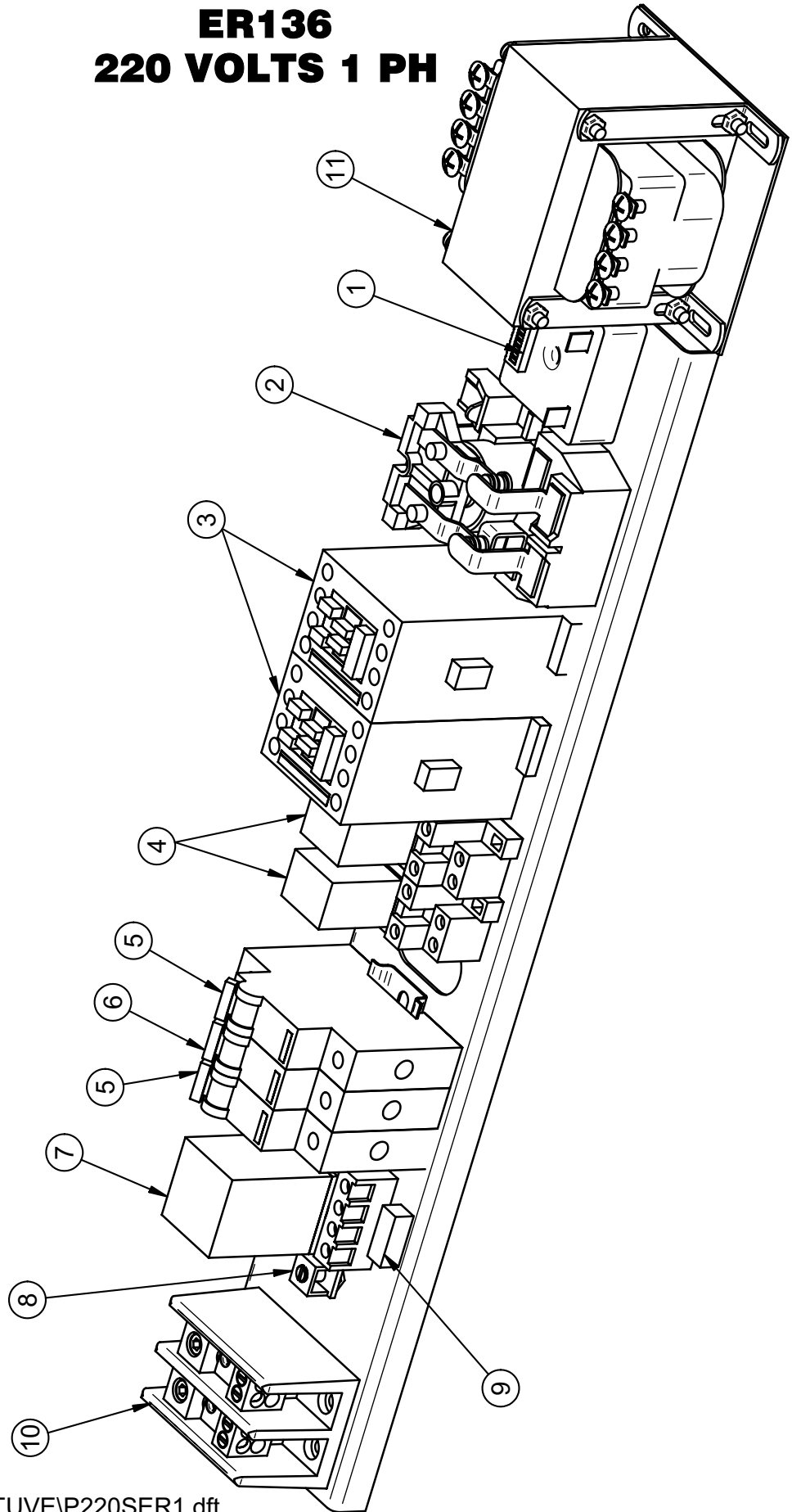

Item	Part Number	Description	Quantity
1	ELM735	SOLID STATE TIMER ICM FOR CH460,JAOP3G, FC2G AND E233	1
2	ELC650	RELAY 2P 30A 120VAC	1
3	ELC908	HEATING CONTACTOR	2
4	ELC630	CONTROL RELAY 12A COIL 120V	2
AND	ELC640	CONTROL RELAY BASE	2
5	ELB107	15A BREAKER	2
6	ELB109	30A BREAKER	1
7	ELC615	RELAY 10A 2P COIL 110V	1
AND	ELC617	BASE	1
8	ELL050	GROUND LUG	1
9	ELM736	LOAD FOR TIMER	1
10	ELB071	TERMINAL BLOCK 2P 175A 1PHASE	1
11	ELT720	TRANSFORMER 240/120V 200VA	1

Model : 220V 1PH ER136 (P220SER1)

View : TOP

ER236 208 OR 240 VOLTS 1 PH

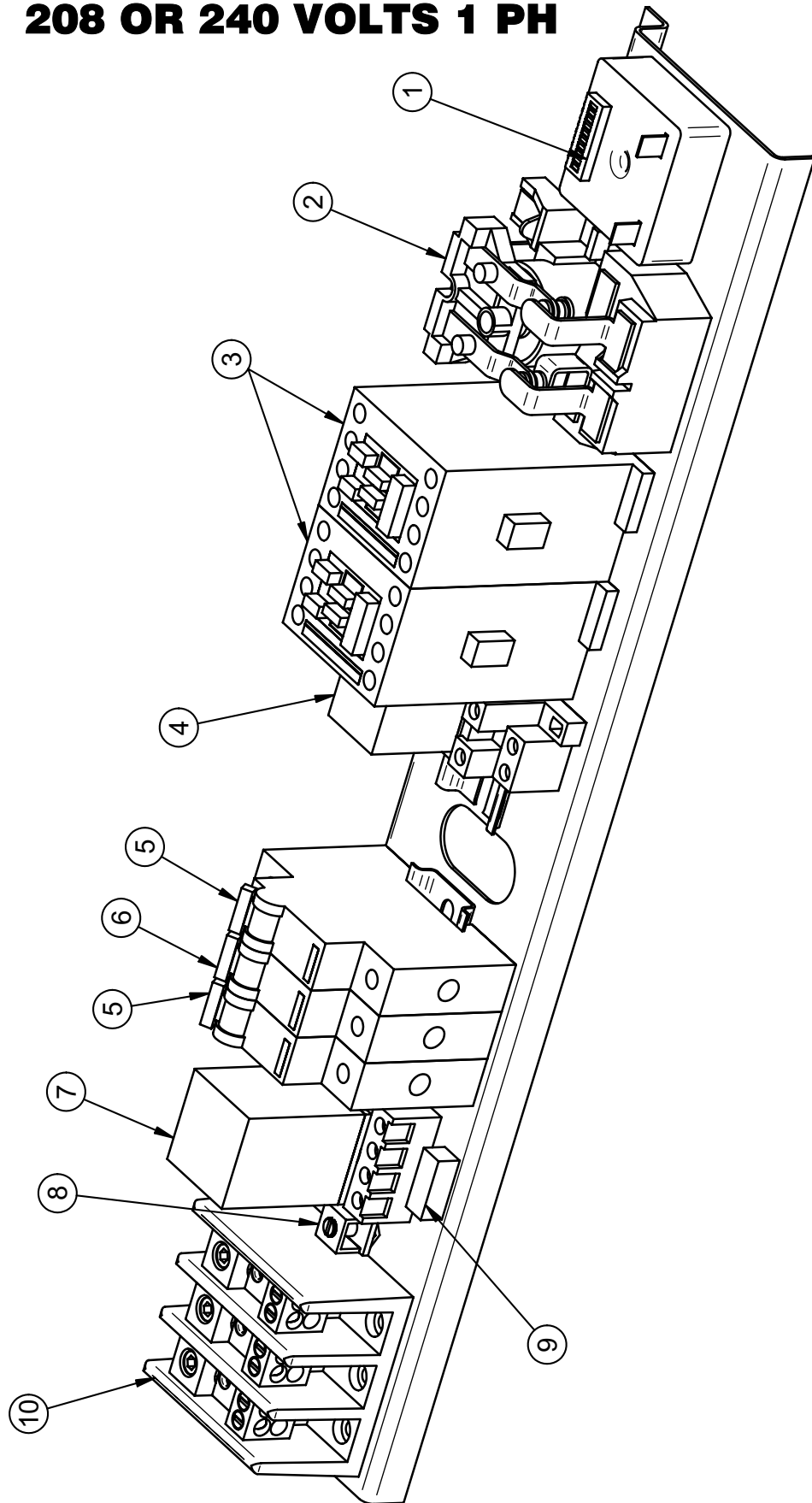

F7

Item	Part Number	Description	Quantity
1	ELM735	SOLID STATE TIMER ICM FOR CH460,JAOP3G, FC2G AND E233	1
2	ELC650	RELAY 2P 30A 120VAC	1
3	ELC908	HEATING CONTACTOR	2
4	ELC630	CONTROL RELAY 12A COIL 120V	1
AND	ELC640	CONTROL RELAY BASE	1
5	ELB107	15A BREAKER	2
6	ELB109	30A BREAKER	1
7	ELC615	RELAY 10A 2P COIL 110V	1
AND	ELC617	BASE	1
8	ELL050	GROUND LUG	1
9	ELM736	LOAD FOR TIMER	1
10	ELB072	TERMINAL BLOCK 3P 175A	1

Model : 240V 1PH ER236 (P240SER2)

View : TOP

ER236 220 VOLTS 1 PH

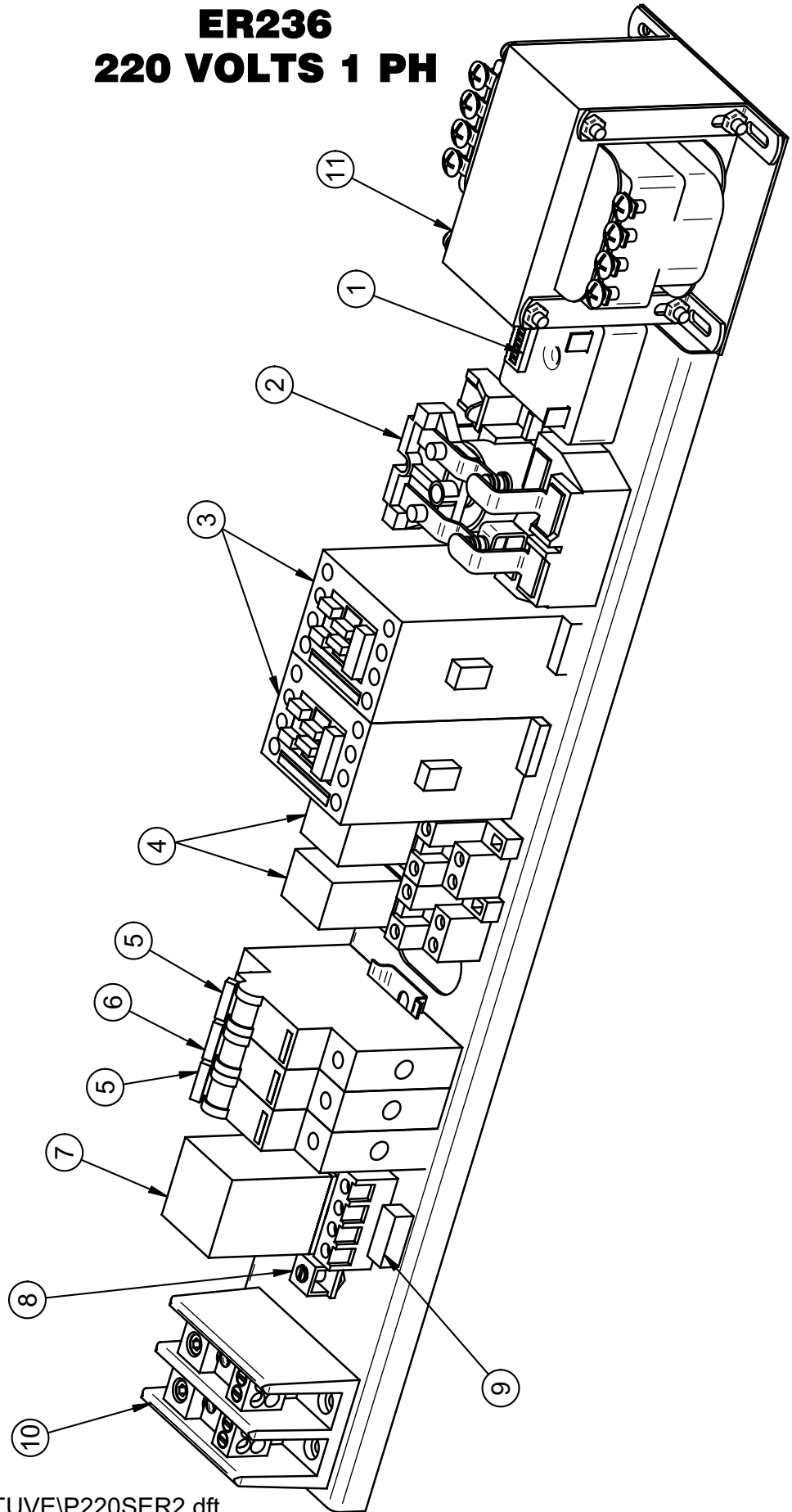

Item	Part Number	Description	Quantity
1	ELM735	SOLID STATE TIMER ICM FOR CH460,JAOP3G, FC2G AND E233	1
2	ELC650	RELAY 2P 30A 120VAC	1
3	ELC908	HEATING CONTACTOR	2
4	ELC630	CONTROL RELAY 12A COIL 120V	2
AND	ELC640	CONTROL RELAY BASE	2
5	ELB107	15A BREAKER	2
6	ELB109	30A BREAKER	1
7	ELC615	RELAY 10A 2P COIL 110V	1
AND	ELC617	BASE	1
8	ELL050	GROUND LUG	1
9	ELM736	LOAD FOR TIMER	1
10	ELB071	TERMINAL BLOCK 2P 175A 1PHASE	1
11	ELT720	TRANSFORMER 240/120V 200VA	1

Model : 220V 1PH ER236 (P220SER2)

View : TOP

SECTION
G

ELECTRIC SCHEMATICS

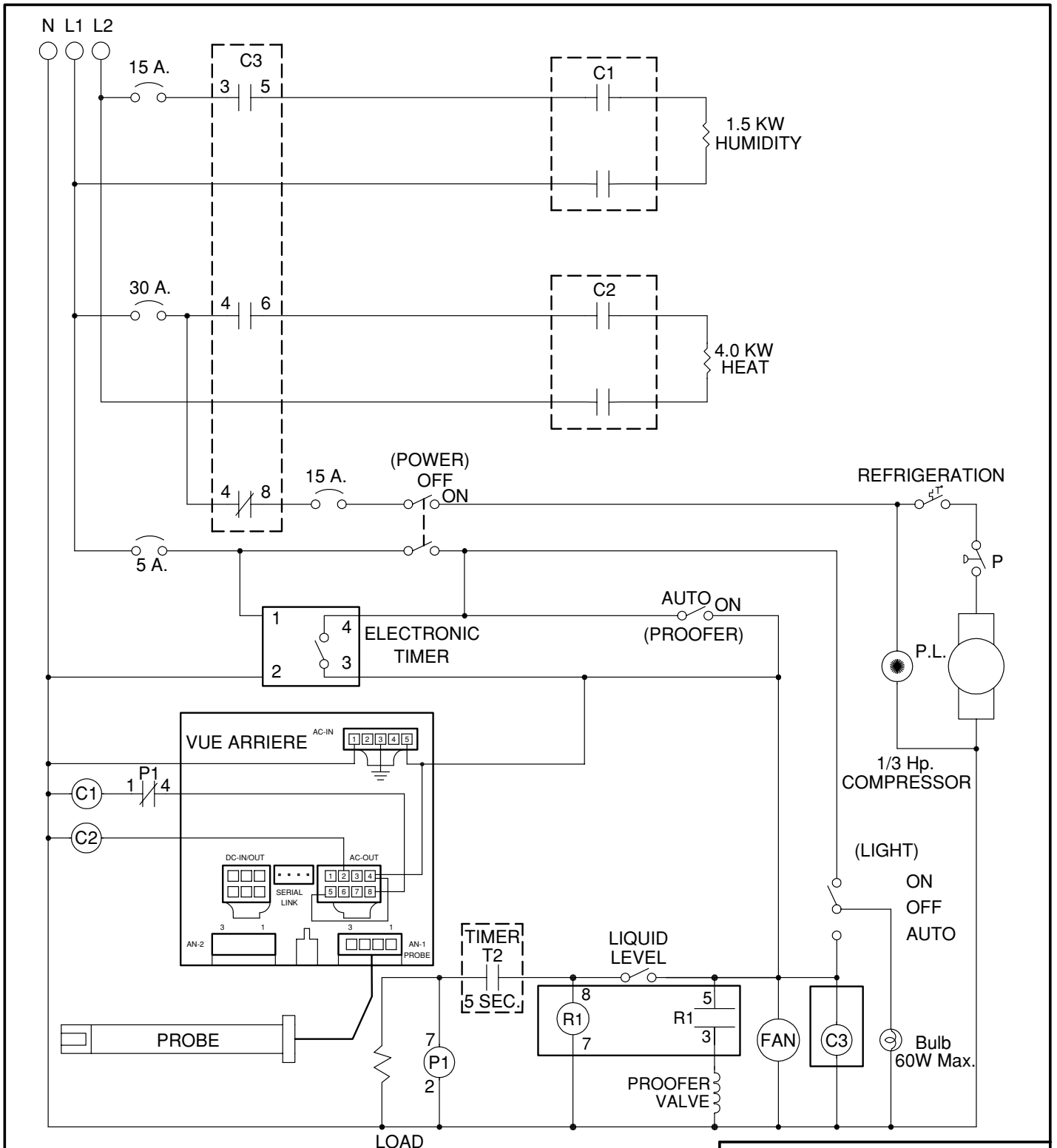

VOLTAGE	N	L1	L2
120 / 208	8A	27A	26A
120 / 240	8A	24A	23A

TOTAL POWER: 6KW 60HZ

EQUIPEMENT
DOYON

ER136 1 PHASE 60HZ

DATE	TECHN.	REV.	SECTION
23/08/05	M. FAUCHER	8	1 / 1
LAYERS OFF	MODEL	NO.	
NONE	STANDARD	ER136_1	

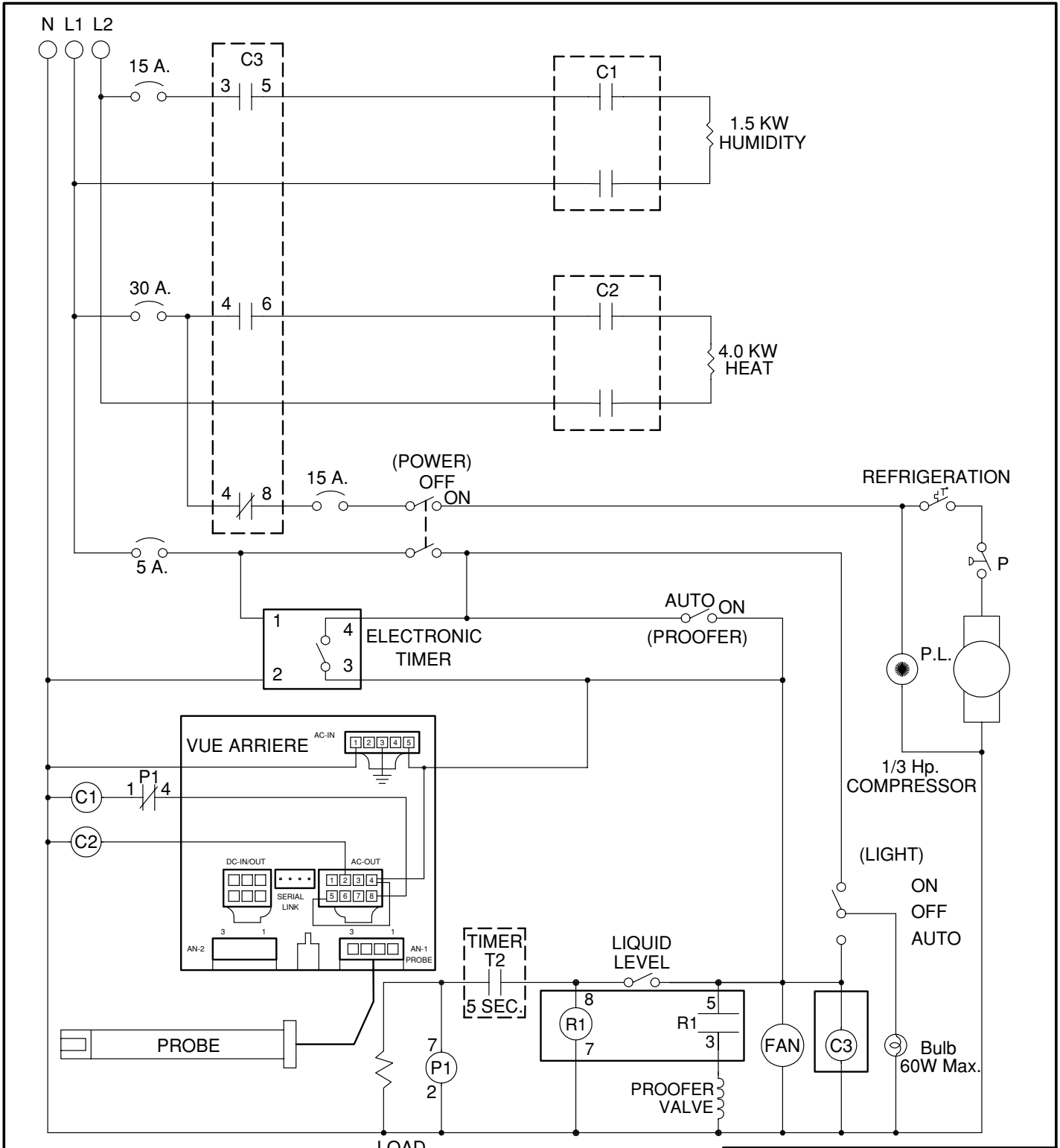

VOLTAGE	N	L1	L2
120 / 208	8A	27A	26A
120 / 240	8A	24A	23A

TOTAL POWER: 6KW 60HZ

EQUIPEMENT
DOYON

ER136 1 PHASE 60HZ

DATE	TECHN.	REV.	SECTION
23/08/05	M. FAUCHER	8	1 / 1
LAYERS OFF	MODEL	NO.	
NONE	STANDARD	ER136_1	

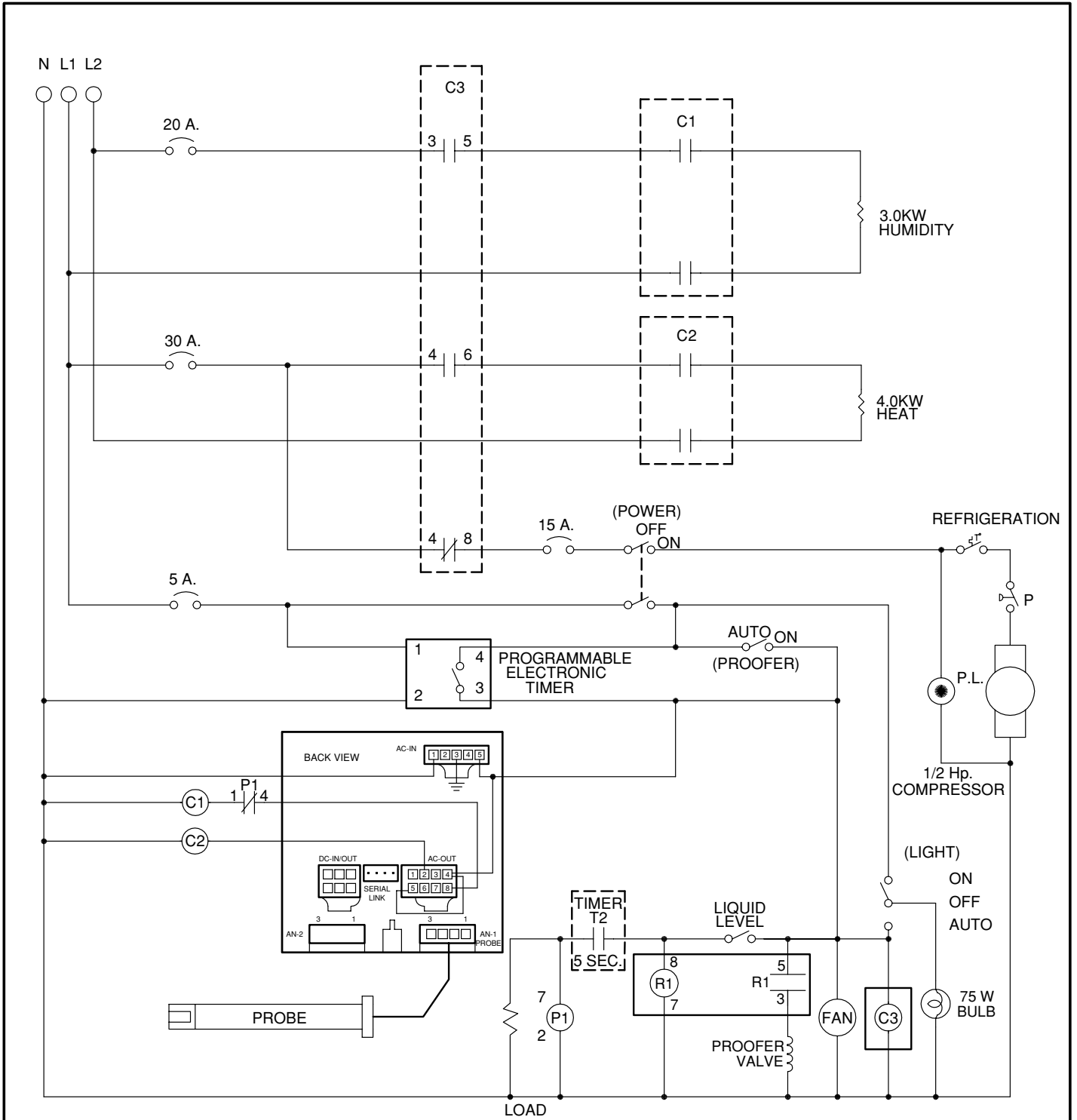

VOLTAGE	N	L1	KW
120 / 208	11.0A	34.6A	33.6A
120 / 240	11.0A	30.0A	29.0A

TOTAL POWER: 60 HZ 7.2KW

EQUIPEMENT
DOYON

ER236 1 PHASE 60 HZ

DATE 23/08/05	TECHN. M. FAUCHER	REV. 8	SECTION 1 / 1
LAYERS OFF NONE	MODEL STANDARD	NO. ER236_1	

LIMITED WARRANTY

(Continental United States Of America And Canada Only)

Doyon Equipment Inc. guarantees to the original purchaser only that its product are free of defects in material and workmanship, under normal use.

This warranty does not cover any light bulbs, thermostat calibration or defects due to or resulting from handling, abuse, misuse, nor shall it extend to any unit from which the serial number has been removed or altered, or modifications made by unauthorized service personnel or damage by flood, fire or other acts of God. Nor will this warranty apply as regards to the immersion element damaged by hard water.

The extent of the manufacturer's obligation under this warranty shall be limited to the replacement or repair of defective parts within the warranty period. The decision of the acceptance of the warranty will be made by Doyon Equipment service department, which decision will be final.

The purchaser is responsible for having the equipment properly installed, operated under normal conditions with proper supervision and to perform periodic preventive maintenance.

If any parts are proven defective during the period of one year from date of purchase, Doyon Equipment Inc. hereby guarantees to replace, without charge, F.O.B. Linière, Quebec, Canada, such part or parts.

Doyon Equipment Inc will pay the reasonable labor charges in connection with the replacement parts occurring within one year from purchase date. Travel over 50 miles, holiday or overtime charges are not covered. After one year from purchase date, all labor and transportation charges in connection with replacement parts will be the purchaser's responsibility.

Doyon Equipment Inc. does hereby exclude and shall not be liable to purchaser for any consequential or incidental damages including, but not limited to, damages to property, damages for loss of use, loss of time, loss of profits or income, resulting from any breach or warranty.

In no case, shall this warranty apply outside Canada and continental United States unless the purchaser has a written agreement from Doyon Equipment Inc.