

# Milk, Ice Cream and Milk & Ice Cream Dispensers Service and Installation Manual

Please read this manual completely before attempting to install or operate this equipment! **Notify carrier of damage!** Inspect all components immediately. See page 2.



**N, N6/N10/N14**  
Free-standing milk or  
beverage dispensers



**NDF**  
Free-standing milk or  
beverage dispensers



**NLFAC**  
Free-standing milk or beverage  
dispensers with air curtain



**NSCF, SCF**  
Free-standing ice cream  
dispensers and milk & ice  
cream dispensers

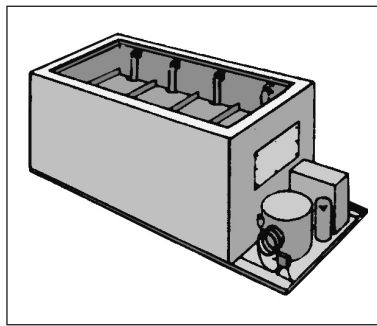

**MF, MFSC, FF,  
FFSC, RFF, RFFSC**  
Built-in milk or beverage,  
ice cream, and milk & ice cream  
dispensers



**IMPORTANT INFORMATION  
READ BEFORE USE  
PLEASE SAVE THESE INSTRUCTIONS!**

## CONTENTS

SERIAL NUMBER LOCATION .....	2
RECEIVING & INSPECTING EQUIPMENT .....	2
SPECIFICATIONS.....	3
REFRIGERANT NOTES.....	3
INSTALLATION .....	4-5
OPERATION.....	6
MAINTENANCE .....	7
WIRING DIAGRAM .....	8
REPLACEMENT PARTS LISTS.....	9-10
STANDARD LABOR GUIDELINES.....	11
STANDARD WARRANTIES .....	12-13
AUTHORIZED PARTS DEPOTS.....	back cover

©2003 The Delfield Company. All rights reserved. Reproduction without written permission is prohibited. "Delfield" and "Shelleymatic" are registered trademarks of The Delfield Company.

## SERIAL NUMBER LOCATION

### Serial number tag locations

**MF/MFSC, FF/FFSC and RFF/RFFSC** — on the end above the refrigeration system.

**N, N6/N10/N14, and SCF** — rear of the unit above the louver.

**NDF** — Front right hand corner under the lid.

**NLFAC** — at the rear of the unit by the power cord.

Always have the serial number of your unit available when calling for parts or service. A complete list of authorized Delfield parts depots is shown on the back cover of this manual.

The units represented in this manual are for indoor use only.

## RECEIVING AND INSPECTING THE EQUIPMENT

Even though most equipment is shipped crated, care should be taken during unloading so the equipment is not damaged while being moved into the building.

1. Visually inspect the exterior of the package and skid or container. Any damage should be noted and reported to the delivering carrier immediately.
2. If damaged, open and inspect the contents with the carrier.
3. In the event that the exterior is not damaged, yet upon opening, there is concealed damage to the equipment notify the carrier. Notification should be made verbally as well as in written form.
4. Request an inspection by the shipping company of the damaged equipment. This should be done within 10 days from receipt of the equipment.
5. Check the lower portion of the unit to be sure casters are not bent.

6. Also open the compressor compartment housing and visually inspect the refrigeration package. Be sure lines are secure and base is still intact.
7. Freight carriers can supply the necessary damage forms upon request.
8. Retain all crating material until an inspection has been made or waived.

### Uncrating the Equipment

First cut and remove the banding from around the crate. Remove the front of the crate material, use of some tools will be required. If the unit is on legs remove the top of the crate as well and lift the unit off the skid. If the unit is on casters it can be rolled off the skid.

# SPECIFICATIONS

MODEL NUMBER	H.P.	LOADING/DISPENSING	AMPS (115V)	NEMA PLUG	BTU LOAD	REF CAP.	REF CHG.
<b>Self-cont. free-standing milk or beverage dispensers</b>							
N-520	1/4	sliding top lids	5.0	5-15P	189	1035	16oz
N-860	1/4	sliding top lids	5.0	5-15P	259	1167	16oz
N-1200	1/4	sliding top lids	5.0	5-15P	328	1273	16oz
N-1530	1/4	sliding top lids	5.0	5-15P	398	1360	16oz
N6-1313-33	1/4	sliding top lids	5.0	5-15P	245	1167	16oz
N6-1313-37	1/4	sliding top lids	5.0	5-15P	245	1167	16oz
N10-1313-33	1/4	sliding top lids	5.0	5-15P	353	1315	16oz
N10-1313-37	1/4	sliding top lids	5.0	5-15P	353	1315	16oz
N14-1313-33	1/4	sliding top lids	5.0	5-15P	455	1422	16oz
N14-1313-37	1/4	sliding top lids	5.0	5-15P	455	1422	16oz

<b>Self-cont. free-standing milk or beverage dispensers</b>							
NDF-12	1/4	drop front & flip top lids	5.0	5-15P	687	1204	16oz
NDF-18	1/3	drop front & flip top lids	7.0	5-15P	898	1585	24oz

<b>Self-cont. free-standing milk or beverage dispensers with air curtain (BTU is with lids closed.)</b>							
NLFAC-8	1/3	hinged lids w/air curtain	7.0	5-15P	668	2184	24oz
NLFAC-12	1/2	hinged lids w/air curtain	9.0	5-15P	859	2885	32oz
NLFAC-16	1/2	hinged lids w/air curtain	9.0	5-15P	1050	3193	32oz

MODEL NUMBER	H.P.	LOADING/DISPENSING BODY STYLE	AMPS (115V)	NEMA PLUG	BTU LOAD	REF CAP.	REF CHG.
<b>Self-cont. free-standing milk and ice cream dispensers</b>							
NSCF-48	1/4	hinged top lids	6.0	5-15P	139(ref) 414(frz)	1596(ref) 796(frz)	16oz

<b>Self-cont. free-standing ice cream dispensers</b>							
SCF-32	1/4	hinged top lids	6.0	5-15P	709	915	16oz
SCF-48	1/3	hinged top lids	8.0	5-15P	1043	1350	24oz

MODEL NUMBER	H.P.	CUTOUT DIM. (L X D)	AMPS (115V)	NEMA PLUG	BTU LOAD	REF CHARGE	REF CHG
<b>Self-cont. built-in milk or beverage dispensers</b> *a 2.87" space is required between each cutout							
MFSC-2020	1/4	(1) 25" x 22.25"	6.5	5-15P	304	1223	16oz
MFSC-2821	1/4	(1) 10.75" x 21"	6.5	5-15P	264	1166	16oz
MFSC-31	1/4	(2) 10.75" x 21"*	6.5	5-15P	296	1212	16oz
MFSC-44	1/4	(3) 10.75" x 21"*	6.5	5-15P	408	1346	16oz
MFSC-57	1/4	(4) 10.75" x 21"*	6.5	5-15P	519	1447	16oz

MODEL NUMBER	RECOMMENDED H.P.	CUTOUT DIMENSIONS (L X D)	BTU LOAD
<b>Remote built-in milk or beverage dispensers</b> *a 2.87" space is required between each cutout			
MF-2020	1/4	(1) 25.25" x 22.25"	300
MF-2821	1/4	(1) 10.75" x 21"	260
MF-31	1/4	(2) 10.75" x 21"*	300
MF-44	1/4	(3) 10.75" x 21"*	410
MF-57	1/4	(4) 10.75" x 21"*	520

<b>Remote built-in ice cream dispensers</b> *a 2.87" space is required between each cutout			
FF-324	1/4	(1) 10.75" x 21"	430
FF-2	1/3	(2) 10.75" x 21"*	710

MODEL NUMBER	H.P.	CUTOUT DIMENSIONS (L X D)	AMPS (115V)	NEMA PLUG	BTU LOAD	REF CAP.	REF CHG.
<b>Self-cont. built-in ice cream dispensers</b> *a 2.87" space is required between each cutout							
FFSC-324	1/4	(1) 10.75" x 21"	6.0	5-15P	434	763	16oz
FFSC-2	1/3	(2) 10.75" x 21"*	8.0	5-15P	709	915	24oz

<b>Self-cont. built-in milk &amp; ice cream dispensers</b> *a 2.87" space is required between each cutout							
RFFSC-103	1/4	(2) 10.75" x 21"*	6.0	5-15P	139(ref) 414(frz)	1596(ref) 796(frz)	

MODEL NUMBER	RECOMMENDED H.P.	CUTOUT DIMENSIONS (L X D)	BTU LOAD
<b>Remote built-in milk &amp; ice cream dispensers</b> *a 2.87" space is required between each cutout			
RFF-103	1/3	(2) 10.75" x 21"	140

# REFRIGERANT NOTES



MF, MFSC, N, N6/N10/N14, NDF and NLFAC series refrigerators use HFC-134a refrigerant.



FF, FFSC, RFF, RFFSC, SCF, and NSCF freezers use HFC-404A refrigerant.

# INSTALLATION

## Location

Be sure the location chosen has a floor strong enough to support the total weight of the cabinet and contents. Units in this product line can weigh as much as 1500 pounds when it is fully stocked. Reinforce the floor as necessary to provide for maximum loading.

For the most efficient refrigeration, be sure to provide good air circulation inside and out.

**Inside cabinet:** Do not pack unit so full that air cannot circulate. Take care not to block air flow to the fans and allow space along sides.

**Outside cabinet:** Be sure that the unit has access to ample air. Avoid hot corners and locations near stoves and ovens. It is recommended that the rear of the unit be no less than two inches from any wall, partition or any other object which will restrict exhaust air flow.

## Leveling

A level cabinet looks better and will perform better because the cabinet will not be subject to unnecessary strain due to doors not properly lining up with door frames.

Some models have casters for ease of cleaning underneath and for mobility. It is important that the unit be installed in a stable condition with the front casters locked before operating. Locking the front casters after installation is the owner's and operator's responsibility.

## Electrical connection

A standard self-contained unit is provided with a power cord and three-prong grounded plug.

The unit should be plugged into a receptacle with its own circuit protection that matches the amperage of the plug.



**Refer to the amperage data on page three or the serial tag data and your local code or the National Electrical Code to be sure the unit is connected to the proper power source. A protected circuit of the correct voltage and amperage must be run for connection to the unit.**



**The power supply must be disconnected whenever performing maintenance or repairing the equipment!**



**The unit must never be operated without the louvered panel in place.**

## Built-in units

All self-contained units (MFSC, FFSC and RFFSC) are tested at the factory to assure proper operation. The unit should not be installed directly next to high heat generating equipment (ranges, griddles, etc.).

These units are built into the counter from below and must be supported from the bottom. The counter cut-out sizes and power supply requirements are shown in the specifications on page three. All refrigerators have drains located in the bottom of the tank. An appropriate drainage area or container must be provided by the customer. Be sure to place the unit so the pressure control, located near the compressor, can be reached.

For installation of remote units (MF, FF and RFF), consult a refrigeration service company to connect refrigeration lines to the remote condensing unit.



**Self-contained refrigerated units (MFSC, FFSC and RFFSC) require air flow to the compressor. A louver is provided and must be installed in the counter in front of the condenser. An equal size opening at the rear of the cabinet must also be provided to allow warm air to escape. Failure to do so will void all product warranties.**

## Free standing units

All self-contained units (N, N6/10/14, NDF, NLFAC, SCF and NSCF) are tested at the factory to assure proper operation. The unit should not be installed directly next to high heat generating equipment (ranges, griddles, etc.).

These units are free standing, either on legs or casters. The power supply requirements are shown on page three. All free standing units have drains located in the bottom of the tank. An appropriate drainage area or container must be provided by the customer.

Do not place the unit against a wall or any object that will block air circulation through the condensing unit. If the unit must be placed against a wall, leave a minimum of 2" of space for air flow.

## INSTALLATION CONTINUED

### How to adjust self-leveling dispenser

**Tools Needed:** One small flat head screw driver; One Phillips head screw driver.

1. Always wear safety glasses when adjusting your dispenser. Also, lock brakes on mobile units before beginning.
2. Unload dispenser and remove stainless steel load tray by lifting straight up and set it aside (see fig. 1).

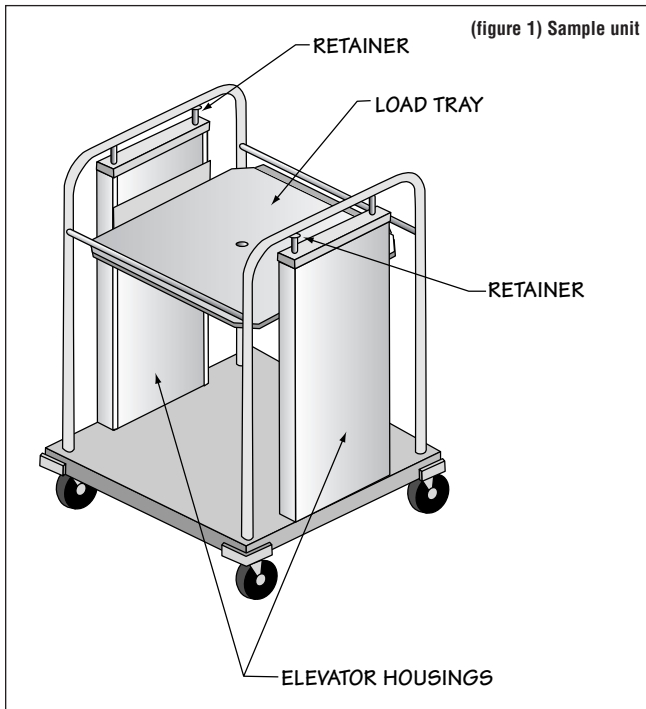

3. Use small regular screw driver to loosen each retainer mounted on stainless steel rod at top of each elevator housing.

4. To remove elevator housing, lift housing straight up to clear the stud on unit base. Then gently swing the bottom of the housing towards the inside of the unit and pull housing out of the unit (see fig. 2). Lay housing on flat surface.



5. Use Phillips head screw driver to remove front panel on the elevator housing (see fig. 3).

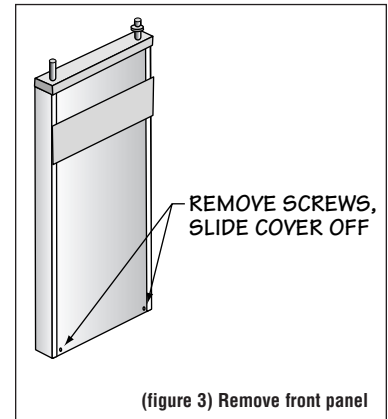

6. If carrier is riding too high, you need to remove springs. With carrier all the way to the top, gently disengage one spring at a time, unhooking bottom loop out of carrier bracket (see fig. 4). Remove as many springs as necessary.

If carrier is riding too low, you need to add springs. With carrier all the way to the top, gently engage one spring at a time by hooking bottom loop of spring into carrier bracket. Add as many springs as necessary.

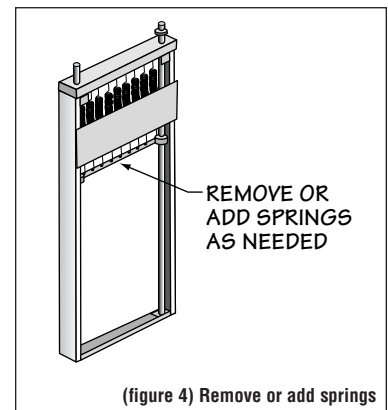

7. When finished, put elevator housing back in unit and put stainless steel load tray back on elevator housings. Load unit to test dispensing level. If spring adjustment does not position carrier properly, repeat procedure #6 trying different springs. If this does not work, a different set of springs may be required. To order, call The Delfield Company Parts and Service Department at 800.733.8829
8. If level is appropriate, put front panels back on and tighten retainer.



**CAUTION:** Dispenser should not be operated with front panels off elevator housing.

**NOTE:** When adjusting the elevators make sure each have the same number and size of springs connected to the carrier on both sides. This will prevent the load tray from binding.

## OPERATION: N, N6/10/14, NDF, NLFAC, MF & MFSC SERIES

**N, N6/10/14, NDF, NLFAC and MFSC Series milk dispensers** are set at the factory to maintain temperatures between 36°F and 40°F. No further adjustment should be necessary. To begin operation on self-contained models, plug the electrical supply cord into a receptacle with the correct voltage. Remote models will require a connection to a separate refrigeration system.

### Loading: N, MF & MFSC Series

To load, place a complete layer of cartons or bottles standing upright on the load tray. Then place a divider tray on top of this layer, then another layer of cartons or bottles on this tray, then another tray and another layer, etc. As each additional tray is loaded, the elevators gradually lower. The last layer may be placed on top without the use of another tray. When loading the average tall half pint bottles, four layers may be loaded into each compartment standing upright and the fifth layer laying down.



**It is very important to use the divider trays provided between each successive layer of contents to assure the correct balance of the load and the proper action of the elevating mechanism.**

Wire racks, when used, should be loaded completely. When placing one rack on top of the other, be sure the stacking lugs are properly aligned.

### Loading: N6/10/14 Series

These cabinets are designed to dispense 13" x 13" x 11" high (maximum dimensions) dairy cases. Place one case

loaded with milk on the carrier and then place a second case loaded with milk on top of the first case. Press down on the cases leaning them toward the retaining bracket located under the top lid track, then gradually release pressure on the cases so that the top edge of the case engages with the retaining bracket.

The elevating mechanism is designed to keep the contents several inches below the top of the cabinet when fully loaded. This distance serves two purposes:

- A. It keeps the top layer of milk completely refrigerated even when the lids are removed.
- B. It insures that the lids will operate without striking the contents as successive layers are added.

### Loading: NDF Series

These cabinets are designed to dispense 13" x 13" x 11" high (maximum dimensions) dairy cases. They do not have a self-leveling mechanism. Simply place the cases on top of each other inside the cabinet through the wide opening in the top and front.

### Loading: NLFAC Series

These cabinets are designed to dispense 13" x 13" x 11" high (maximum dimensions) dairy cases. Model NLFAC-8 holds eight cases; four on the bottom and four on the top. Model NLFAC-12 holds twelve cases; six on the bottom and six on the top. Model NLFAC-16 holds sixteen cases, eight on the bottom and eight on the top.

Milk cases are loaded through the wide opening in the top and front of the unit. Fold the hinged lids up and back and rest them on the top. The cabinet interior has self-locating guides installed to make loading easy.

## OPERATION: FFSC, RFFSC, SCF & NSCF SERIES

FFSC and SCF Series ice cream dispensers are set at the factory to maintain temperatures between -5°F and 0°F. RFFSC and NSCF Series combination milk and ice cream dispensers are set at the factory to maintain temperatures between 36°F and 40°F for refrigerated product and between -5°F and 0°F for frozen product. Each combination unit is constructed with two tanks and separate controls. No further adjustments should be necessary. To begin operation plug the electrical supply cord into a receptacle with the correct voltage.

### Loading

To load, place two layers of ice cream on the load tray, then a tray, two additional layers of ice cream, then another tray, etc. Do not stack ice cream above the frost line on the interior of the freezer. See the instructions for the MF units (above) for loading the refrigerated portion of the combination units.

## MAINTENANCE

### Cleaning the unit

The interior and exterior can be cleaned using soap and warm water. If this is not sufficient, try ammonia and water or a non-abrasive liquid cleaner.

The lid and lid openings should be cleaned with a sponge and mild soap solution on a daily basis to maintain their ability to seal.



**When cleaning the exterior, always rub with the “grain” of the stainless steel to avoid marring the finish. Do not use an abrasive cleaner because it will scratch the stainless steel and plastic.**

**Do not use a sharp tool or knife to scrape any gaskets as this may tear the gasket and ruin its ability to seal.**

**Do not use full strength degreasing agents on the gaskets as they could cause the gasket to crack and become brittle.**

**The inside wall of these units house the evaporator coil (cooling coil). Never use a sharp object to remove frost or ice as this may cause the unit to lose its freon charge and will void all warranties.**



### Cleaning the NLFAC milk dispensers

The following special instructions apply to the model NLFAC dispenser only. After cleaning the interior and exterior as described above, be sure to return the milk case loading tray to the bottom of the unit. The load tray is required not only for easy self-locating of milk cases, but it also ensures proper air flow through the evaporator coil for the air curtain.



**Any restriction to the air flow path, including leaving the milk case load tray out of the cabinet, will result in the voiding of your warranties.**

A drain is supplied to simplify cleaning of the interior. Open the clamp used to close off the drain tube. Drain accumulated liquid from the cabinet. Be sure to re-clamp the tubing before resuming operation of the NLFAC unit.

### Honeycomb Cleaning Procedure

Remove the honeycomb material from the equipment. Soak in fresh hot dishwater for five minutes. Rinse by spraying soap off with warm water, directing the spray into the holes. Repeat rinsing steps until material is visibly clean. Soak in sanitizing solution for five minutes. Replace into equipment.

### Defrosting

If there is 3/8” accumulation of ice formation on the interior wall, the unit must be turned off to defrost.



### Cleaning the condenser

**To maintain peak refrigeration performance, the condenser coil fins must be cleaned of dust, grease and food particles every 60 days.**

If conditions are such that the condenser is totally blocked in two months, the frequency of cleaning should be increased. The condenser can be cleaned with a stiff brush or vacuum cleaner. Using high pressure such as compressed air is recommended to thoroughly clean the coil.



**Failure to follow the recommended methods and frequency of condenser coil cleaning will result in reduced refrigeration efficiency and possible damage to the equipment. It may also invalidate your warranties.**

### Low pressure control settings

The factory recommended low pressure control settings for using HFC-134a refrigerant are 30 psig cut-in with a 20 psig differential. For units using HFC-404A refrigerant, the pressure control settings are 30 psig cut-in with a 25 psig differential.

The temperature is controlled by an adjustable pressure control located in the machine compartment. An adjustable control has the word **COLDER** near the knob, with an arrow to indicate the adjustment direction. These controls are field adjustable and do not require a service agent. If you have any questions, feel free to contact the Delfield Service Department.

**In attempting to adjust the pressure control, you can do damage to your unit by accidentally adjusting the differential. Please make small incremental adjustments if a temperature adjustment is necessary, please contact the service department at Delfield (800) 733-8829 #1, or your local service agent. Delfield is not responsible for charges incurred while having the pressure control adjusted.**

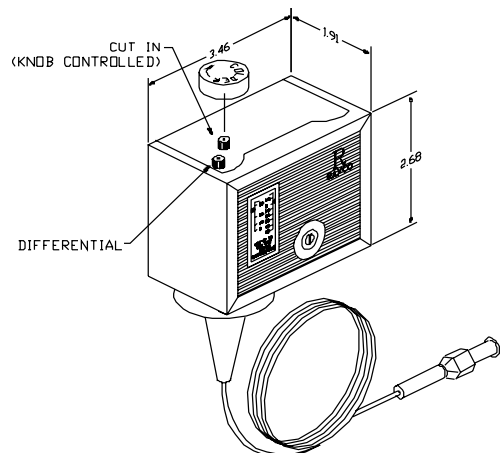

# WIRING DIAGRAMS

## MODELS — MFSC, & RFFSC

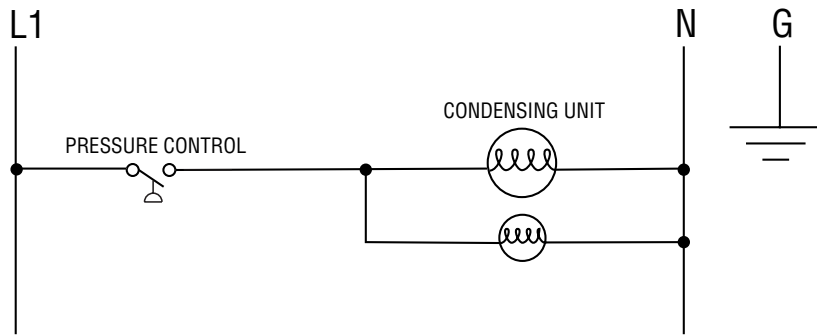

## MODELS — N, SCF, NSCF, & NDF

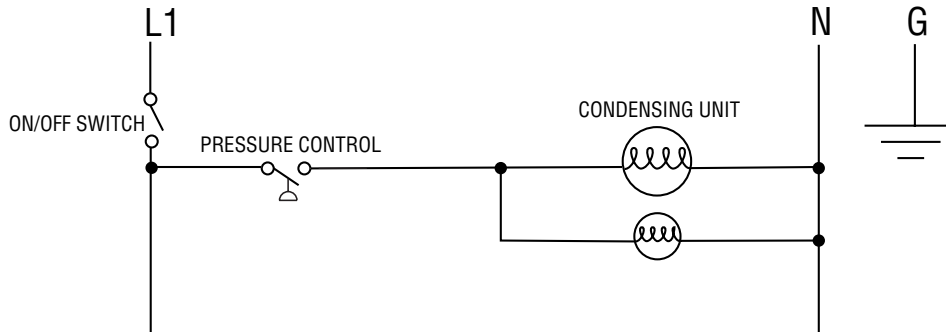

## MODEL — NLFAC

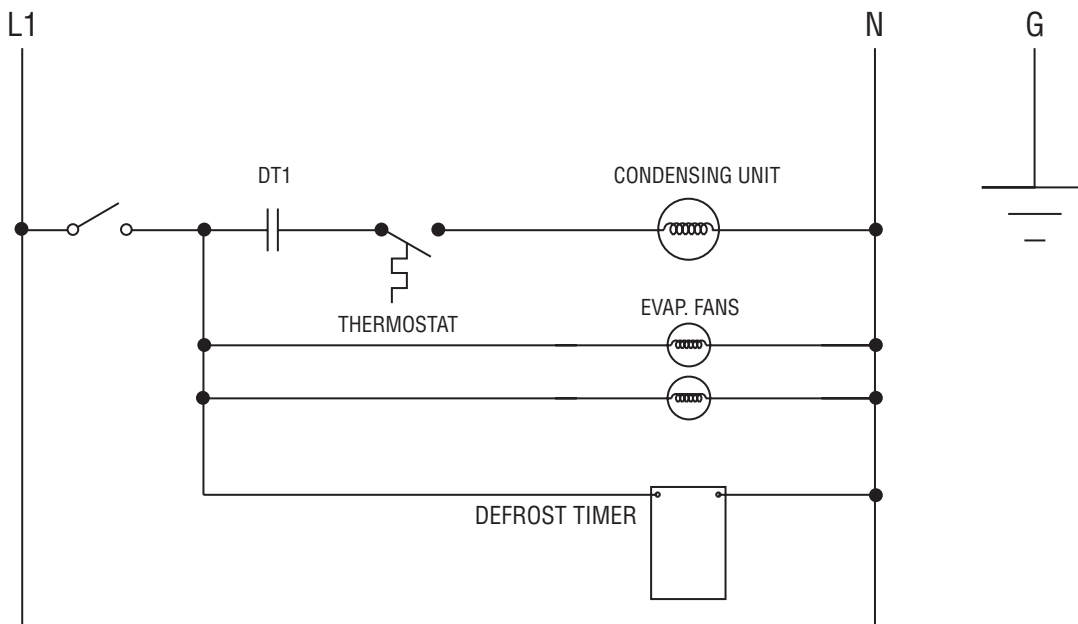

# PARTS REPLACEMENT

## MFSC-2020

Plastic drain	3324242
1" rubber drain stopper	3234021
Lrg. elevator assy	0201737
Bearing	6320007
Extension spring .58 lbs	6150201
Extension spring .28 lbs	6150202
Retainer	6530024
Carrier	0047745
Throat collar	0044074
Lid assy	0201525
Hinge #1 extruded	6230109
Plastic hinge insert	6230110
Top lid assy	0047769
Exp. valve	3516062
Exp. valve cover	0052417
Cond. unit	3526674
Filter dryer	3516101
Pressure control	2193927
Louver	2214110003
Cord/plug assy.	2183348

## MFSC-2821, MFSC-31, MFSC-44,

<b>MFSC-57</b>	
Plastic drain	3234242
1" rubber drain stopper	3234021
Small elevator assy.	0201768
Bearing	6320007
Small elevator plate carrier	0048574
Extension spring .58 lbs	6150201
Retainer	6530024
Carrier	0048347
Large drip proof lid	3234188
Throat collar	6700029
Divider tray	0040006
Cond. unit	3526674
Filter dryer	3516101
Pressure control	2193927
Exp. valve	3516062
Exp. valve cover	0052417
Louver	2214110003
Cord/plug assy.	2183348

## MF-2020

Plastic drain	3234242
1" rubber drain stopper	3234021
Large elevator assy.	0201737
Bearing	6320007
Extension spring .58 lbs	6150201
Extension spring .28 lbs	6150202
Retainer	6530024
Carrier	0047745
Throat collar	0044074
Lid assy.	0201525
Extruded hinge	6230109
Plastic hinge	6230110
Exp. valve	3516062
Exp. valve cover	0052417

## MF-2821, MF-31, MF-44, MF-57

Plastic drain	3234242
1" rubber drain stopper	3234021
Small elevator assy.	0201768
Bearing	6320007
Extension spring .58 lbs	6150201
Retainer	6530024
Carrier	0048347
Large drip proof lid	3234188
Throat collar	6700029
Divider tray	0040006
Exp. valve	3516062
Exp. valve cover	0052417

## FFSC-3324

Plastic drain	3234242
1" rubber drain stopper	3234021
Small elevator assy.	0201768
Bearing	6320007
Extension spring .58 lbs	6150201
Retainer	6530024
Carrier	0048347
Large drip proof lid	3234188
Throat collar	6700029
Divider tray	0040006
Cond. unit	3526709
Filter dryer	3516101
Pressure control	2193927
Exp. valve	3516273
Exp. valve cover	0051417
Louver	2214110003
Cord/plug assy.	2183348

## FFSC-2

Plastic drain	3234242
1" rubber drain stopper	3234021
Small elevator assy.	0201768
Bearing	6320007
Extension spring .58 lbs	6150201
Retainer	6530024
Carrier	0048347
Large drip proof lid	3234188
Throat collar	6700029
Divider tray	0040006
Cond. unit	3526710
Filter dryer	3516101
Pressure control	2193927
Exp. valve	3516273
Exp. valve cover	0051417
Louver	2214110003
Cord/Plug Assy.	2183348

## FF-3324

Plastic drain	3234242
1" rubber drain stopper	3234021
Small elevator assy.	0201768
Bearing	6320007
Extension spring .58 lbs	6150201
Retainer	6530024
Carrier	0048347
Large drip proof lid	3234188
Throat collar	6700029
Divider tray	0040006
Exp. valve	3516273
Exp. valve cover	0051417

## FF-2

Plastic drain	3234242
1" rubber drain stopper	3234021
Small elevator assy.	0201768
Bearing	6320007
Extension spring .58 lbs	6150201
Retainer	6530024
Carrier	0048347
Large drip proof lid	3234188
Throat collar	6700029
Divider tray	0040006
Exp. valve	3516273
Exp. valve cover	0051417

## RFFSC-103

Plastic drain	3234242
1" rubber drain stopper	3234021
Small elevator assy.	0201768
Bearing	6320007
Extension spring .58 lbs	6150201
Retainer	6530024
Carrier	0048347
Large drip proof lid	3234188
Throat collar	6700029
Divider tray	0040006
Cond. unit	3526709
Filter dryer	3516101
Pressure control	2193927
Exp. valve 1/4 low	3516225
Exp. valve 1/4 hi	3516273
Exp. valve cover	1701278
Louver	2214110003
EPR valve 3/8 inlet/outlet	3516265
Cord/Plug Assy.	2183348

## RFF-103

Plastic drain	3234242
1" rubber drain stopper	3234021
Small elevator assy.	0201768
Bearing	6320007
Extension spring .58 lbs	6150201
Retainer	6530024
Carrier	0048347
Large drip proof lid	3234188
Throat collar	6700029
Divider tray	0040006
Exp. valve 1/4 low	3516225
Exp. valve 1/4 hi	3516273
Exp. valve cover	0052417

## N520, N860, N1200

1" plastic drain	3234242
Cond. unit	3526674
Filter dryer	3516101
Pressure control	2193927
Exp. valve	3516062
Sensing blub holding clip	3516205
Top sliding lid assy.	0201316
4" chrome lift cover handle	3234110
Bottom sliding lid assy.	0201317
Louver 9 x 13.50	0048864
Louver 13 x 25	221411003
N-series carrier	0047121
N-series divider tray	0040005
Elevator assy.	0201768
Bearing	6320007
Ext. spring	6150201
Retainer	6230024
Elevator assy. Frzr	0201770
Louver side 13 x 13.50	0047033
Rocker switch	2190154
6" leg with remov. foot	3234645
Cord/plug assy.	2183348
3/4 valve drain	6690493

## N-1530

1" plastic drain	3234242
Cond. unit	3526674
Filter dryer	3516101
Pressure control	2193927
Exp. valve	3516062
Sensing blub holding clip	3516205
Top sliding lid assy.	0201318
4" chrome lift cover handle	3234110
Bottom sliding lid assy.	0201319
Louver 9 x 13.50	0048864
Louver 13 x 25	221411003
N-series divider tray	0040005
Bearing	6320007
Ext. spring	6150201
Retainer	6230024

Sliding lid assy bottom	0201317
4" chrome lift cover handle	3234110
Louver side 13 x 13.50	0047033
Rocker switch	2190154
6" leg with remov. foot	3234645
Cord/plug assy.	2183348
3/4 valve drain	6690493

## N-6-1313-37, N6-1313-34

1" plastic drain	3234242
Cond. unit	3526674
Filter dryer	3516101
Pressure control	2193927
Exp. valve	3516062
Sensing blub holding clip	3516205
Sliding lid track	6230016
Lid assy bottom	0201331
Lid assy top	0201330
Louver 13 x 13.50	0047033
Louver side 9 x 13.50	0048864
Louver 13 x 25	221411003
Milk crate carrier	0047906
Elevator assy.	0201764
Bearing	6320007
Ext. spring	6150201
Retainer	6230024
Rocker switch	2190154
6" leg with remov. foot	3234645
Cord/plug assy.	2183348
3/4 valve drain	6690493

## N-10-1313-34, N-10-1313-37

1" plastic drain	3234242
Cond. unit	3526674
Filter dryer	3516101
Pressure control	2193927
Exp. valve	3516062
Sensing blub holding clip	3516205
Sliding lid track	6230016
Lid assy bottom	0201333
Top sliding lid assy.	0201332
Louver 13 x 13.50	0047033
Louver side 9 x 13.50	0048864
Louver 13 x 25	221411003
Milk crate carrier	0047906
Elevator assy.	0201764
Bearing	6320007
Ext. spring	6150201
Retainer	6230024
Rocker switch	2190154
6" leg with remov. foot	3234645
Cord/plug assy.	2183348
3/4 valve drain	6690493

## N-14-1313-34

1" plastic drain	3234242
Cond. unit	3526674
Filter dryer	3516101
Pressure control	2193927
Exp. valve	3516062
Sensing blub holding clip	3516205
Sliding lid track	6230016
Lid assy bottom	0201333
Top sliding lid assy.	0201334
Louver 13 x 13.50	0047033
Louver side 9 x 13.50	0048864
Louver 13 x 25	221411003
Bearing	6320007
Ext. spring	6150201
Retainer	6230024
Rocker switch	2190154
6" leg with remov. foot	3234645
Cord/plug assy.	2183348
3/4 valve drain	6690493

Continued on the next page.



# PARTS REPLACEMENT

<b>N-14-1313-37</b>		Fan blade	3516172	Alum in-between hinge	6230019	Carrier large	0048347
1" plastic drain	3234242	Fan guard	3516173	Heavy duty hinge	6230020	Divider tray	0040006
Cond. unit	3526674	Fan motor	2162691	Plastic hinge insert	6230110	Large drip proof lid	3234188
Filter dryer	3516101	Thermostat	2194536	Milk crate divider	0047067	Louver side 13 x 13.50	0047033
Pressure control	2193927	Cover assy.	0202128	Louver 13 x 25	2214110003	Louver 13 x 25	221411003
Exp. valve	3516062	Lid assy front	0202130	Louvered door front RH	0048922	Louver side 9 x 13.50	0048864
Sensing blub holding clip	3516205	Thimble	6230014	Louvered door front LH	0048097	Rocker switch	2190154
Sliding lid track	6230016	Alum in-between hinge	6230017	Hinge flag 1"	3234067	6" leg with removable foot	3234645
Lid assy bottom	0201333	Heavy duty hinge	6230020	Magnetic snap in catch	3234156	Drain valve	6690493
Top sliding lid assy.	0201334	Plastic hinge insert	6230110	Dry door steel strike	SMK01071		
Louver 13 x 13.50	0047033	Milk crate divider	0047067	Bumper	9321079		
Louver side 9 x 13.50	0048864	Louver 13. X 22	0060131			<b>SCF-50</b>	
Louver 13 x 25	221411003	Louvered door frame	0048910	<b>SCF-32</b>		5" caster	3234161
Bearing	6320007	Louvered door front LH	0048085	1" plastic drain	3234242	1" plastic drain	3234242
Ext. spring	6150201	Hinge flag 1"	3234067	1" rubber drain stopper	3234021	1" rubber drain stopper	3234021
Retainer	6230024	Magnetic snap in catch	3234156	Exp. valve	3516225	Elevator assy.	0201768
Milk crate carrier	0047906	Dry door steel strike	SMK01071	Sensing bulb holding clip	3516205	Bearing	6320007
Elevator assy.	0201764	Bumper	9321079	Cond. unit	3526709	Extension spring .058 lbs	6150201
Rocker switch	2190154			Filter dryer	3516101	Retainer	6230024
6" leg with remov. foot	3234645	<b>NFLAC-12</b>		Pressure control	2193927	Carrier large	0048347
Cord/plug assy.	2183348	Glass door lock assy	3234684	Cord/plug assy.	2183348	Divider tray	0040006
3/4 valve drain	6690493	5" caster	3234161	Exp. valve cover	1701278	Large drip proof lid	3234188
		Door track	6230008	Elevator assy.	0201768	Cond. unit	3526709
<b>NDF-12</b>		Cond. unit	3526688	Bearing	6320007	Filter dryer	3516101
4" caster	3234180	Filter dryer	3516101	Extension spring .058 lbs	6150201	Pressure control	2193927
Cond. unit	3526674	Cord/plug assy.	2183348	Retainer	6230024	Cord/plug assy.	2183348
Filter dryer	3516101	Bushing	6190096	Carrier large	0048347	Louver end flat	221411001
Pressure control	2193927	Thermometer dial	3516133	Divider tray	0040006	Louver front rear	221411000
Dry door tension catch	3234307	Rocker switch	2190154	Large drip proof lid	3234188	Rocker switch	2190154
Thermometer	3516059	Timer	2194345	Louver side 13 x 13.50	0047033	Drain valve	6690493
1" Plastic drain	3234242	Evap. coil	3516065	Louver 13 x 25	221411003		
Top lid assy.	0201176	Exp. valve	3516062	Louver side 9 x 13.50	0048864		
Snap in gasket	6700007	Honeycomb diffuser clear	1701083	Rocker switch	2190154		
Key lock	6230003	Egg crate diffuser black	1701082	6" leg with removable foot	3234645		
Hinge/pin assy. LH	0201178	Fan blade	3516172	Drain valve	6690493		
Hinge/pin assy. RH	0201177	Fan guard	3516173				
Front lid assy	0201181	Fan motor	2162691	<b>SCF-48</b>			
Bumper	9321005	Thermostat	2194536	1" plastic drain	3234242		
Corner bumper	6230170	Cover assy.	0202132	1" rubber drain stopper	3234021		
Cord/plug assy.	2183348	Lid assy front	0202133	Exp. valve	3516225		
Drain valve	6690493	Thimble	6230014	Sensing bulb holding clip	3516205		
		Alum. in-between hinge	6230018	Cond. unit	3526710		
<b>NDF-18</b>		Heavy duty hinge	6230020	Filter dryer	3516101		
4" caster	3234180	Plastic hinge insert	6230110	Pressure control	2193927		
Cond unit	3526675	Milk crate divider	0047067	Cord/plug assy.	2183348		
Filter dryer	3516101	Louver 13 x 25	2214110003	Exp. valve cover	1701278		
Pressure control	2193927	Louvered door front RH	0048922	Elevator assy.	0201768		
Dry door tension catch	3234307	Louvered door front LH	0048097	Bearing	6320007		
Thermometer	3516059	Hinge flag 1"	3234067	Extension spring .058 lbs	6150201		
1" Plastic drain	3234242	Magnetic snap in catch	3234156	Retainer	6230024		
Top lid assy.	0201184	Dry door steel strike	SMK01071	Carrier large	0048347		
Snap in gasket	6700008	Bumper	9321079	Divider tray	0040006		
Key lock	6230003			Large drip proof lid	3234188		
Hinge/pin assy. LH	0201178	<b>NFLAC-16</b>		Louver side 13 x 13.50	0047033		
Hinge/pin assy. RH	0201177	Glass door lock assy	3234684	Louver 13 x 25	221411003		
Front lid assy	0201185	5" caster	3234161	Louver side 9 x 13.50	0048864		
Bumper	9321005	Door track	6230009	Rocker switch	2190154		
Corner bumper	6230170	Cond unit	3526689	6" leg with removable foot	3234645		
Cord/plug assy.	2183348	Filter dryer	3516101	Drain valve	6690493		
Drain valve	6690493	Cord/plug assy.	2183348				
		Bushing	6190096	<b>NSCF-48</b>			
<b>NFLAC-8</b>		Thermometer dial	3516133	1" plastic drain	3234242		
Glass door lock assy	3234684	Rocker switch	2190154	Cond. unit	3526709		
5" caster	3234161	Timer	2194345	Filter dryer	3516101		
Door track	6230007	Evap. coil	3516065	Pressure control	2193927		
Cond unit	3526675	Exp. valve	3516062	Exp. valve	2516225		
Filter dryer	3516101	Honeycomb diffuser clear	1701083	Exp. valve	3516273		
Cord/plug assy.	2183348	Egg crate diffuser black	1701082	Sensing bulb holding clip	3516205		
Thermometer dial	3516133	Fan blade	3516172	Expansion valve cover	1701278		
Rocker switch	2190154	Fan guard	3516173	EPR valve	3516265		
Timer	2194345	Fan motor	2162691	Cord/plug assy.	2183348		
Evap. Coil	3516065	Thermostat	2194536	Elevator assy.	0201768		
Exp. valve	3516062	Cover assy.	0202141	Bearing	6320007		
Honeycomb diffuser clear	1701083	Lid assy front	0202142	Extension spring .058 lbs	6150201		
Egg crate diffuser black	1701082	Thimble	6230014	Retainer	6230024		

**STANDARD LABOR GUIDELINES TO REPAIR OR REPLACE PARTS ON DELFIELD EQUIPMENT**

Advice and recommendations given by Delfield Service Technicians do not constitute or guarantee any special coverage.

- A maximum of 1-hour is allowed to **diagnose a defective component**.
- A maximum of 1-hour is allowed for **retrieval of parts** not in stock.
- A maximum **travel distance** of 100 miles round trip and 2-hours will be reimbursed.
- Overtime, installation/start-up, normal control adjustments, general maintenance, glass breakage, freight damage, and/or correcting and end-user installation error will not be reimbursed under warranty unless pre-approved with a **Service Work Authorization** from Delfield. You must submit the number with the service claim.

**LABOR OF 1-HOUR IS ALLOWED TO REPLACE:**

- Thermostat
- Infinite Switch
- Door Jamb Switch
- Solenoid Coil
- Hi-limit/Thermal Protector Switch
- Fan Delay/Defrost Termination Switch
- Compressor Start Components and Overload Protector
- Defrost Timer
- Thermometer
- Gear Box
- Contactor/Relay
- Transformer
- Evaporator/Condenser Fan Motor and Blade
- Circulating Fan Motor and Blade
- Microprocessor Control
- Water Level Sensor/Probe
- Door Hinges, Locks, and Gaskets
- Condensate Element
- Springs/Lowerator

**LABOR OF 2 HOURS TO REPLACE:**

- Drawer Tracks/Cartridges
- Pressure Control
- Solenoid Valve
- Defrost Element
- Heating Element
- Locate/Repair Leak

**LABOR OF 3 HOURS TO REPLACE:**

- EPR or CPR Valve
- Expansion Valve
- Condenser or Evaporator Coil

**LABOR OF 4 HOURS TO REPLACE**

- Compressor

This includes recovery of refrigerant and leak check.

\$35.00 maximum reimbursement for refrigerant recovery (includes recovery machine, pump, torch, oil, flux, minor fittings, solder, brazing rod, nitrogen, or similar fees.)

**REFRIGERANTS**

- R22 A maximum of \$4.00/lb. or 25¢/oz. will be reimbursed.
- R134A A maximum of \$5.00/lb. or 31¢/oz. will be reimbursed.
- R404A A maximum of \$12.00/lb. or 75¢/oz. will be reimbursed.



### STANDARD ONE YEAR WARRANTY (ONE YEAR PARTS, 90 DAYS LABOR.)

The Delfield Company ("Delfield") warrants to the Original Purchaser of the Delfield product (herein called the "Unit") that such Unit, and all parts thereof, will be free from defects in material and workmanship under normal use and service for a period of one (1) year from the date of shipment of the Unit to the Original Purchaser **or, if the Original Purchaser returns the warranty card completely filled out including the date of installation within thirty (30) days of receipt of the Unit, one (1) year from the date of installation.** During this one year warranty period, Delfield will repair or replace any defective part or portion thereof returned to Delfield by the Original Purchaser which Delfield determines was defective due to faulty material or workmanship. The Original purchaser will pay all labor, crating, freight and related costs incurred in the removal of the Unit of defective component and shipment to Delfield, except that during a period of either ninety (90) days from the date of shipment of the Unit to the Original Purchaser or, if the Original Purchaser returns the warranty card completely filled out including the date of installation within thirty (30) days of receipt of the Unit, ninety (90) days from the date of installation Delfield will pay all related labor costs. Delfield will pay the return costs if the Unit or part thereof was defective.

The term "Original Purchaser" as used herein means that person, firm, association, or corporation for whom the Unit was originally installed.

This warranty does not apply to any Unit or part thereof that has been subjected to misuse, neglect, alteration, or accident, such as accidental damage to the exterior finish, operated contrary to the recommendations specified by Delfield; or repaired or altered by anyone other than Delfield in any way so as to, in Delfield's sole judgement, affect its quality or efficiency. This warranty does not apply to any Unit that has been moved from the location where it was originally installed. This warranty also does not cover the refrigerator drier or the light bulbs used in the Unit. **The warranty is subject to the user's normal maintenance and care responsibility as set forth in the Service and Installation Manual, such as cleaning the condenser coil, and is in lieu of all other obligations of Delfield. Delfield neither assumes, nor authorizes any other person to assume for Delfield, any other liability in connection with Delfield's products.**

Removal or defacement of the original Serial Number or Model Number from any Unit shall be deemed to release Delfield from all obligations hereunder or any other obligations, express or implied.

Parts furnished by suppliers to Delfield are guaranteed by Delfield only to the extent of the original manufacturer's express warranty to Delfield. Failure of the Original Purchaser to receive such manufacturer's express warranty to Delfield. Failure of the Original Purchaser to receive such manufacturer's warranty shall in no way create any warranty, expressed or implied, or any other obligation or liability on Delfield's part in respect thereof.

**IF THE CUSTOMER IS USING A PART THAT RESULTS IN A VOIDED WARRANTY AND A DELFIELD AUTHORIZED REPRESENTATIVE TRAVELS TO THE INSTALLATION ADDRESS TO PERFORM WARRANTY SERVICE, THE SERVICE REPRESENTATIVE WILL ADVISE CUSTOMER THE WARRANTY IS VOID. SUCH SERVICE CALLS WILL BE BILLED TO CUSTOMER AT THE AUTHORIZED SERVICE CENTER'S THEN APPLICABLE TIME AND MATERIALS RATES. CONSIDER: CUSTOMER MAY INITIATE A SERVICE AGREEMENT WITHOUT PARTS COVERAGE.**

If shipment of a replacement part is requested prior to the arrival in the Delfield factory of the part claimed to be defective, the Original Purchaser must accept delivery of the replacement part of a C.O.D.

basis, with credit being issued after the part has been received and inspected at Delfield's plant and determined by Delfield to be within this warranty.

Under no condition does this warranty give the Original Purchaser the right to replace the defective Unit with a complete Unit of the same manufacturer or of another make. Unless authorized by Delfield in writing, this warranty does not permit the replacement of any part, including the motor-compressor, to be made with the part of another make or manufacturer.

No claims can be made under this warranty for spoilage of any products for any reason, including system failure.

The installation contractor shall be responsible for building access, entrance and field conditions to insure sufficient clearance to allow any hood(s), vent(s), or Unit(s) if necessary, to be brought into the building. Delfield will not be responsible for structural changes or damages incurred during installation of the Unit or any exhaust system.

Delfield shall not be liable in any manner for any default or delay in performance hereunder caused by or resulting from any contingency beyond Delfield's control, including, but not limited to, war, governmental restrictions or restraints, strike, lockouts, injunctions, fire, flood, acts of nature, short or reduced supply of raw materials, or discontinuance of the parts by the original part manufacturer.

**Except as provided in any Additional Four Year Protection Plan, if applicable, and the Service Labor Contract, if applicable, the foregoing is exclusive and in lieu of all other warranties, whether written or oral, express or implied. This warranty supersedes and excludes any prior oral or written representations or warranties. Delfield expressly disclaims any implied warranties of merchantability, fitness for a particular purpose of compliance with any law, treaty, rule or regulation relating to the discharge of substances into the environment. The sole and exclusive remedies of any person relating to the Unit, and the full liability of Delfield for any breach of this warranty, will be as provided in this warranty.**

Other than this Delfield Standard One Year Limited Warranty, any applicable Delfield Additional Four Year Protection Plan or applicable Delfield Service Labor Contract, the Original Purchaser agrees and acknowledges that no other warranties are offered or provided in connection with or for the unit or any other part thereof.

In no event will Delfield be liable for special, incidental or consequential damages, or for damages in the nature of penalties.

**IF DURING THE WARRANTY PERIOD, CUSTOMER USES A PART FOR THIS DELFIELD EQUIPMENT OTHER THAN AN UNMODIFIED NEW OR RECYCLED PART PURCHASED DIRECTLY FROM DELFIELD OR ANY OF ITS AUTHORIZED SERVICE CENTERS AND/OR THE PART BEING USED IS MODIFIED FROM ITS ORIGINAL CONFIGURATION, THIS WARRANTY WILL BE VOID. FURTHER, DELFIELD AND ITS AFFILIATES WILL NOT BE LIABLE FOR ANY CLAIMS DAMAGES OR EXPENSES INCURRED BY THE CUSTOMER WHICH ARISE DIRECTLY OR INDIRECTLY, IN WHOLE OR IN PART, DUE TO THE INSTALLATION OF ANY MODIFIED PART AND/OR PART RECEIVED FROM AN UNAUTHORIZED SERVICE CENTER. If the warranty becomes void, Customer may purchase from Delfield, if available, a Service Agreement or service at the then current time and materials rate.**

For more information on Delfield warranty's log on and check out the service section of our web site at [www.delfield.com](http://www.delfield.com).

**ADDITIONAL FOUR YEAR PROTECTION PLAN** (FOR MOTOR-COMPRESSOR ONLY)

Delfield Model#	Serial #	Installation Date

In addition to the Standard One Year Warranty on the Motor-Compressor contained in the above listed Delfield product (the "Unit"), The Delfield Company ("Delfield") also agrees to repair, or exchange with similar or interchangeable parts in design and capacity at Delfield's option, the defective Motor-Compressor contained in the Unit (the "Motor-Compressor"), or any part thereof, for the Original Purchaser only, at any time during the four (4) years following the initial one (1) year period commencing on the date of installation for the Original Purchaser. **Failure of the Original Purchaser to register the registration card containing the Original Purchasers name, address, date of installation, model number and serial number of the Unit containing the Motor-Compressor within 30 days from the date of installation shall void this warranty.** This additional warranty is only available if the Motor-Compressor is inoperative due to defects in material or factory workmanship, as determined by Delfield in its sole judgement and discretion. The Original Purchaser shall be responsible for returning the defective Motor-Compressor to Delfield prepaid, F.O.B. at the address shown on the back cover of this manual.

The term "Original Purchaser" as used herein means that person, firm, association, or corporation for whom the Unit was originally installed.

The term "Motor-Compressor" as used herein does not include unit base, air or water cooled condenser, receiver, electrical accessories such as relay, capacitors, refrigerant controls, or condenser fan/motor assembly. This warranty does not cover labor charges incidental to the replacement of parts. This warranty further does not include any equipment to which said condensing unit is connected, such as cooling coils, temperature controls or refrigerant metering devices. This warranty shall be void if the Motor-Compressor, in Delfield's sole judgement, has been subjected to misuse, neglect, alteration or accident, operated contrary to the recommendations specified by the Unit manufacturer, repaired or altered by anyone other than Delfield in any way so as, in Delfield's sole judgment, to affect its quality or efficiency or if the serial number has been altered, defaced or removed. This Warranty does not apply to a Motor-Compressor in any Unit that has been moved from the location where it was originally installed. The addition of methyl chloride to the condensing unit or refrigeration system shall void this warranty.

**General Conditions**

Delfield shall not be liable in any manner for any default or delay in performance hereunder caused by or resulting from any contingency beyond Delfield's control, including, but not limited to, war, governmental restrictions or restraints, strike, lockouts, injunctions, fire, flood, acts of nature, short or reduced supply of raw materials, or discontinuance of any part or the Motor-Compressor by the unit manufacturer.

Replacement of a defective Motor-Compressor is limited to one (1) Motor-Compressor by us during the four (4) year period. Delfield shall replace the Motor-Compressor at no charge.

This warranty does not give the Original Purchaser of the Motor-Compressor the right to purchase a complete replacement Motor-Compressor of the same make or of another make. It further does not permit the replacement to be made with a Motor-Compressor of another kind unless authorized by Delfield. In the event Delfield authorizes the Original Purchaser to purchase a replacement Motor-Compressor locally, only the wholesale cost of the Motor-Compressor is refundable.

Expressly excluded from this warranty are damages resulting from spoilage of goods.

**Except as provided in any applicable Standard One Year Limited Warranty or applicable Service Labor Contract, the foregoing is exclusive and in lieu of all other warranties, whether written or oral, express or implied. This Warranty supersedes and excludes any prior oral or written representations or warranties. Delfield expressly disclaims any implied warranties of merchantability, fitness for a particular purpose or compliance with any law, treaty, rule or regulation relating to the Motor-Compressor, and the full liability of Delfield for any breach of this warranty, will be as provided in this warranty.**

Other than any applicable Delfield Standard One year Limited Warranty, this Delfield Additional Four Year Protection Plan and any applicable Delfield Service Labor Contract, the Original Purchaser agrees and acknowledges that no other warranties are offered or provided in connection with or for the Motor-Compressor or any part thereof.

In no event will Delfield be liable for special, incidental or consequential damages, or for damages in the nature of penalties.



**NOTES:**

**NOTES:**



# AUTHORIZED PARTS DEPOTS

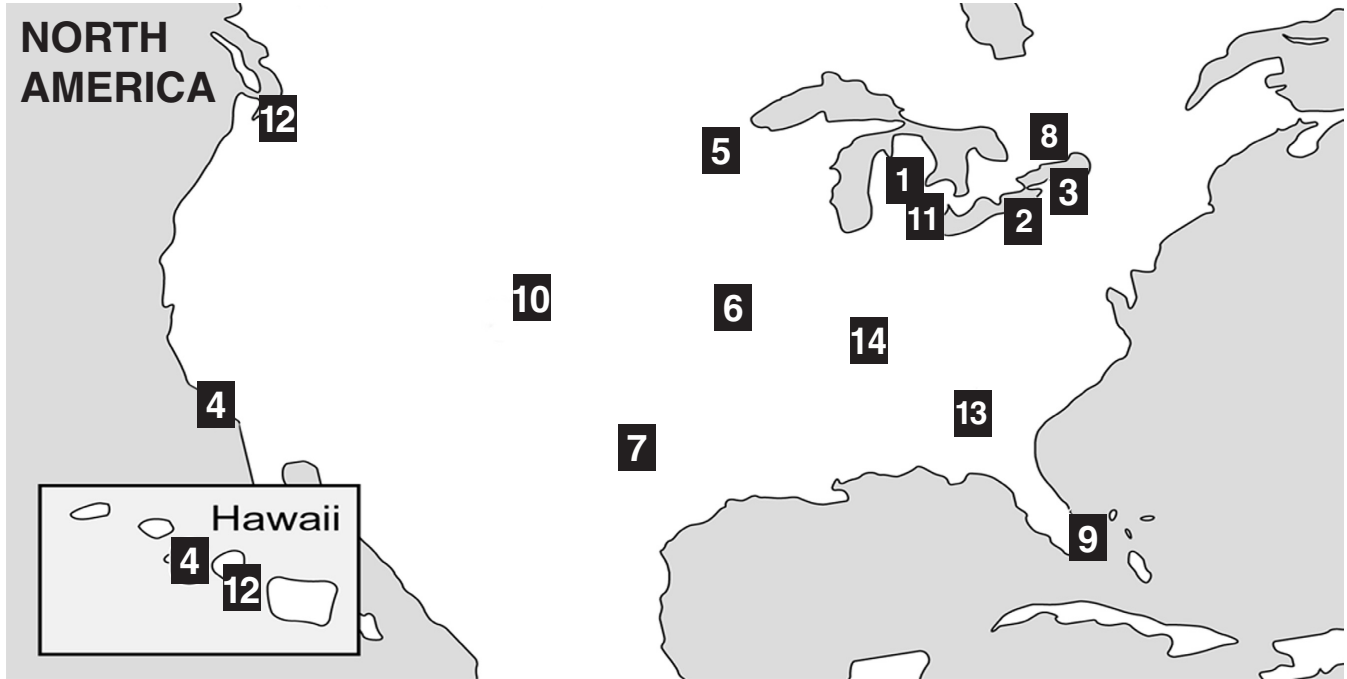

<p><b>1) The Delfield Company</b></p> <p>980 South Isabella Road Mt. Pleasant, MI 48858 800.733.8829 989.773.7981 989.773.3210 FAX custom parts direct from Delfield</p>	<p><b>2) A.I.S. Commercial Parts &amp; Service</b></p> <p>1816 West 26th Street Erie, PA 16508-1149 800.332.3732 814.456.3732 814.452.4843 FAX serves: MD, NJ, OH, PA, VA, WV</p>	<p><b>3) Appliance Installation Service</b></p> <p>1336 Main Street Buffalo, NY 14209 800.722.1252 716.884.7425 716.884.0410 FAX serves: CT, DC, DE, MA, MD, ME, NH, NJ, NY, PA, RI, VA, VT, WV</p>	<p><b>4) Pacific Coast Parts</b></p> <p>15024 Staff Court Gardena, CA 90248 1.800.531.1111 1.800.782.5747 Email: orders@pacparts.com www.pacparts.com serves: AZ, CA, HI, NV, OR</p>
<p><b>5) Contract Ice</b></p> <p>14450 Ewing Ave S. #100 Burnsville, MN 55306 800.422.2823 952.894.4427 952.894.2164 FAX serves: IA, MN, MT, ND, SD, WI</p>	<p><b>6) E.M.C.O. Sales &amp; Distributors</b></p> <p>3909 St. Timothy Lane St. Ann, MO 63074 800.972.7670 314.427.7477 314.427.8190 FAX serves: AR, IA, IL, KS, KY, MO, NE, OK, TX, NM, LA</p>	<p><b>7) Stove Parts Supply/GCS Service</b></p> <p>2120 Solona St. PO Box 14009 Fort Worth, TX 76117-0009 1.800.433.1804 toll free 1.800.272.7358 fax serves: AR, LA, NM, OK, TX</p>	<p><b>8) Garland Group</b></p> <p>1177 Kamato Road Mississauga, Ontario L4W1X4 800.427.6668 800.361.7745 FAX serves: Canada</p>
<p><b>9) Global Parts and Supplies</b></p> <p>2920 N.W. 109th Avenue Miami, FL 33172 305.994.9994 305.994.9992 FAX International parts depot</p>	<p><b>10) Hawkins Commercial Appl. Serv.</b></p> <p>3000 S. Wyandot Englewood, CO 80110 (800) 624-2117 (303) 7618861 FAX serves: AZ, CO, KS, NE, NM, OK, UT, WY</p>	<p><b>11) MicroDine, Inc.</b></p> <p>44792 Helm Plymouth, MI 48170 888.828.4454 734.451.2043 734.451.3215 FAX serves: MI, IN, WI, OH</p>	<p><b>12) Performance Refrigeration Parts</b></p> <p>9923 S.W. 178th St. Vashon, WA 98070 888.872.2465 206-463-1772 206.463.4431 FAX serves: AK, HI, ID, MT, OR, WA</p>
<p><b>13) Southeastern Restaurant Services</b></p> <p>2200 Norcross Parkway, Suite 210 Atlanta, GA 30071 800.235.6516 770.446.6177 770.446.3157 FAX serves: FL, GA, MS, NC, SC, VA</p>	<p><b>14) T.M.A.</b></p> <p>2916 Sidco Drive Nashville, TN 37204 615.726.0351 800.737.0351 615.259.4100 FAX serves: TN, AL</p>	<p><b>Delfield has 14 conveniently located Parts Depots to ensure parts are handled promptly and accurately.</b></p> <p>Delfield reserves the right to update or make changes to this list without prior notice</p> <p>Please call 1-800-733-8829 or check the web at <a href="http://www.delfield.com">www.delfield.com</a> for a list of the current Parts Depots.</p>	



980 S. Isabella Rd., Mt. Pleasant, MI 48804-0470, U.S.A. • (989) 773-7981 or (800) 733-8821 • Fax (800) 669-0619 • [www.delfield.com](http://www.delfield.com)  
Delfield reserves the right to make changes in design or specifications without prior notice. ©2003 The Delfield Company. All rights reserved. Printed in the U.S.A.

MMMLKICE 06/03