

# Dispensing Models

## Service and Installation Manual

Please read this manual completely before attempting to install or operate this equipment! **Notify carrier of damage!** Inspect all components immediately. See page 2.



**DIS**

Drop-in dish dispensers



**CAB**

Mobile enclosed dish dispensers



**CT**

Mobile cantilever tray/rack dispensers



**LT**

Drop-in tray dispensers



**TT**

Mobile tray/rack dispensers



**CD**

Disposable cup dispensers



**TG**

Built in tray and rack dispensers



**WCT**

Wall mounted cantilever tray and rack dispensers

Also in this manual: **ND, CP, CPB, CM, CMB, T-H, T2, TGH AND F2-SN**



**IMPORTANT INFORMATION  
READ BEFORE USE  
PLEASE SAVE THESE INSTRUCTIONS!**

## CONTENTS

RECEIVING & INSPECTING EQUIPMENT .....	2
SPECIFICATIONS.....	4
INSTALLATION .....	5
OPERATION.....	6-7
WIRING DIAGRAMS .....	8-9
MAINTENANCE .....	10
TROUBLESHOOTING REFERENCE CHART .....	10
ADJUSTING SELF-LEVELING DISPENSER .....	11
REPLACEMENT PARTS LIST.....	12-14
STANDARD LABOR GUIDELINES.....	15
STANDARD WARRANTY.....	16-17
AUTHORIZED PARTS DEPOTS.....	backcover

©2003 The Delfield Company. All rights reserved. Reproduction without written permission is prohibited. "Delfield" & "Shelleymatic" are registered trademarks of The Delfield Company.

## SERIAL NUMBER LOCATION

**Dish Dispensers:** The serial number is located on the dispenser housing. Non-heated equipment are not assigned serial numbers.

**Tray & Rack Dispensers:** The serial number is located on the back of the unit or the underside of the flange.

**Mobile & Built in Chilled Plate & Mug dispensers:** The serial number is located near the compressor.

Always have the serial number of your unit available when calling for parts or service.

The units represented in this manual are intended for indoor use only.

## RECEIVING AND INSPECTING THE EQUIPMENT

Even though most equipment is shipped crated, care should be taken during unloading so the equipment is not damaged while being moved into the building.

1. Visually inspect the exterior of the package and skid or container. Any damage should be noted and reported to the delivering carrier immediately.
2. If damaged, open and inspect the contents with the carrier.
3. In the event that the exterior is not damaged, yet upon opening, there is concealed damage to the equipment notify the carrier. Notification should be made verbally as well as in written form.

4. Request an inspection by the shipping company of the damaged equipment. This should be done within 10 days from receipt of the equipment.
5. Check the lower portion of the unit to be sure the casters are not bent.
6. Retain all crating material until an inspection has been made or waived.

### Uncrating the Equipment

First cut and remove the banding from around the crate. Remove the front of the crate material, use of some tools will be required. If the unit is on legs remove the top of the crate as well and lift the unit off the skid. If the unit is on casters it can be rolled off the skid.

# SPECIFICATIONS

MODEL NUMBER	LENGTH	DEPTH	HEIGHT	MAXIMUM DISH DIA.	VOLTAGE (60Hz/1Ø)	AMPS	NEMA PLUG
<b>Dish Dispensers — Mobile Two Stack</b>							
CAB2-500	28.25	17	36	5	N/A	N/A	N/A
CAB2-575	28.25	17	36	5.75	N/A	N/A	N/A
CAB2-650	28.25	17	36	6.5	N/A	N/A	N/A
CAB2-725	28.25	17	36	7.25	N/A	N/A	N/A
CAB2-813	32.25	17	36	8.12	N/A	N/A	N/A
CAB2-913	32.25	17	36	9.12	N/A	N/A	N/A
CAB2-1013	32.25	17	36	10.12	N/A	N/A	N/A
CAB2-1200	37	19	36	12	N/A	N/A	N/A
CAB2-1450	45	21.5	36	14.5	N/A	N/A	N/A
CAB2-500-ET	28.25	17	36	5	120	15.0	5-15P
CAB2-575-ET	28.25	17	36	5.75	120	15.0	5-15P
CAB2-650-ET	28.25	17	36	6.5	120	15.0	5-15P
CAB2-725-ET	28.25	17	36	7.25	120	15.0	5-15P
CAB2-813-ET	32.25	17	36	8.12	120	15.0	5-15P
CAB2-913-ET	32.25	17	36	9.12	120	15.0	5-15P
CAB2-1013-ET	32.25	17	36	10.12	120	15.0	5-15P
CAB2-1200-ET	37	19	36	12	120	15.0	5-15P
CAB2-1450-ET	42	21.5	36	14.5	120	15.0	5-15P
CAB2-813-QT	32.25	17	36	8.12	120	15.0	5-20P
CAB2-913-QT	32.25	17	36	9.12	120	15.0	5-20P
CAB2-1013-QT	32.25	17	36	10.12	120	15.0	5-20P
CAB2-1200-QT	37	19	36	12	120	15.0	5-20P
CAB2-1450-QT	42	21.5	36	14.5	120	15.0	5-20P
<b>Dish Dispensers — Mobile Three Stack</b>							
CAB3-500	41.25	17	36	5	N/A	N/A	N/A
CAB3-575	41.25	17	36	5.75	N/A	N/A	N/A
CAB3-650	41.25	17	36	6.5	N/A	N/A	N/A
CAB3-725	41.25	17	36	7.25	N/A	N/A	N/A
CAB3-813	47.25	17	36	8.12	N/A	N/A	N/A
CAB3-913	47.25	17	36	9.12	N/A	N/A	N/A
CAB3-1013	47.25	17	36	10.12	N/A	N/A	N/A
CAB3-1200	53.25	19	36	12	N/A	N/A	N/A
CAB3-1450	62	21.5	36	14.5	N/A	N/A	N/A
CAB3-500-ET	41.25	17	36	5	208	9.0	6-20P
CAB3-575-ET	41.25	17	36	5.75	208	9.0	6-20P
CAB3-650-ET	41.25	17	36	6.5	208	9.0	6-20P
CAB3-725-ET	41.25	17	36	7.25	208	9.0	6-20P
CAB3-813-ET	47.25	17	36	8.12	208	9.0	6-20P
CAB3-913-ET	47.25	17	36	9.12	208	9.0	6-20P
CAB3-1013-ET	47.25	17	36	10.12	208	9.0	6-20P
CAB3-1200-ET	53.25	19	36	12	208	9.0	6-20P
CAB3-1450-ET	62	21.5	36	14.5	208	9.0	6-20P
CAB3-813-QT	47.25	17	36	8.12	208	13.0	6-20P
CAB3-913-QT	47.25	17	36	9.12	208	13.0	6-20P
CAB3-1013-QT	47.25	17	36	10.12	208	13.0	6-20P
CAB3-1200-QT	53.25	19	36	12	208	13.0	6-20P
CAB3-1450-QT	62	21.5	36	14.5	208	13.0	6-20P
<b>Dish Dispensers — Mobile Four Stack</b>							
CAB4-500	27	27	36	5	N/A	N/A	N/A
CAB4-575	27	27	36	5.75	N/A	N/A	N/A
CAB4-650	27	27	36	6.5	N/A	N/A	N/A
CAB4-725	27	27	36	7.25	N/A	N/A	N/A
CAB4-813	32.25	32.25	36	8.12	N/A	N/A	N/A
CAB4-913	32.25	32.25	36	9.12	N/A	N/A	N/A
CAB4-1013	32.25	32.25	36	10.12	N/A	N/A	N/A
CAB4-1200	36	36	36	12	N/A	N/A	N/A
CAB4-1450	42	42	36	14.5	N/A	N/A	N/A
CAB4-500-ET	27	27	36	5	208	17.0	6-20P
CAB4-575-ET	27	27	36	5.75	208	17.0	6-20P
CAB4-650-ET	27	27	36	6.5	208	17.0	6-20P
CAB4-725-ET	27	27	36	7.25	208	17.0	6-20P
CAB4-813-ET	32.25	32.25	36	8.12	208	17.0	6-20P
CAB4-913-ET	32.25	32.25	36	9.12	208	17.0	6-20P
CAB4-1013-ET	32.25	32.25	36	10.12	208	17.0	6-20P
CAB4-1200-ET	36	36	36	12	208	17.0	6-20P
CAB4-1450-ET	42	42	36	14.5	208	17.0	6-20P
CAB4-813-QT	32.25	32.25	36	8.12	208	17.0	6-20P
CAB4-913-QT	32.25	32.25	36	9.12	208	17.0	6-20P
CAB4-1013-QT	32.25	32.25	36	10.12	208	17.0	6-20P
CAB4-1200-QT	36	36	36	12	208	17.0	6-20P
CAB4-1450-QT	42	42	36	14.5	208	17.0	6-20P

MODEL NUMBER	FLANGE DIA.	HEIGHT	CUTOUT DIA.	MAXIMUM DISH DIA.	VOLTAGE (60Hz/1Ø)	AMPS	NEMA PLUG
<b>Dish Dispensers — Drop-In</b>							
DIS-500	8.37	28	7.75	5	N/A	N/A	N/A
DIS-575	9.12	28	8.5	5.75	N/A	N/A	N/A
DIS-650	9.87	28	9.25	6.5	N/A	N/A	N/A
DIS-725	10.62	28	10	7.25	N/A	N/A	N/A
DIS-813	11.5	28	10.87	8.12	N/A	N/A	N/A
DIS-913	12.5	28	11.87	9.12	N/A	N/A	N/A
DIS-1013	13.5	28	12.87	10.12	N/A	N/A	N/A
DIS-1200	15.37	28	14.75	12	N/A	N/A	N/A
DIS-1450	17.88	28	17.25	14.5	N/A	N/A	N/A
<b>Dish Dispensers — Drop-In/Heated</b>							
DIS-500-ET	8.37	28	7.75	5	120	8.0	5-15P
DIS-575-ET	9.12	28	8.5	5.75	120	8.0	5-15P
DIS-650-ET	9.87	28	9.25	6.5	120	8.0	5-15P
DIS-725-ET	10.62	28	10	7.25	120	8.0	5-15P
DIS-813-ET	11.5	28	10.87	8.12	120	8.0	5-15P
DIS-913-ET	12.5	28	11.87	9.12	120	8.0	5-15P
DIS-1013-ET	13.5	28	12.87	10.12	120	8.0	5-15P
DIS-1200-ET	15.37	28	14.75	12	120	8.0	5-15P
DIS-1450-ET	17.88	28	17.25	14.5	120	8.0	5-15P
<b>Dish Dispensers — Drop-In/Heated/Quick Temp</b>							
DIS-813-QT	11.5	28	10.87	8.12	120	8.0	5-15P
DIS-913-QT	12.5	28	11.87	9.12	120	8.0	5-15P
DIS-1013-QT	13.5	28	12.87	10.12	120	8.0	5-15P
DIS-1200-QT	15.37	28	14.75	12	120	8.0	5-15P
DIS-1450-QT	17.88	28	17.25	14.5	120	8.0	5-15P

MODEL NUMBER	CUTOUT SIZE	MAXIMUM RACK/TRAY SIZE	LENGTH	DEPTH	HEIGHT
<b>Tray/Rack Dispensers</b>					
LT-2020	22.75 X 26	20 X 20	26.75	27.13	27.5
LT2-1221	27 X 27.75	10 X 20	31.75	28.13	27.5
LT2-1014	23.75 X 21	12 X 16	23.13	31.75	27.5
LT2-1216	27.75 X 22	14 X 21	31.75	28.13	27.5
T-2020	N/A	20 X 20	27.75	28.13	36
TT2-2020	N/A	20 X 20	26.25	25.75	37.75
LT-1014	11.75 X 21	10 X 15	15.75	22.13	27.5
LT-1216	17.75 X 21	12 X 16	21.75	19.13	27.5
LT-1222	19.75 X 21	12 X 21	26.75	19.13	27.5
LT-1418	23.75 X 21	16 X 22	23.75	21.13	27.5
LT-1422	23.75 X 20	14 X 22	27.75	21.13	27.5
LT-1622	27.75 X 21	18 X 26	27.75	23.13	27.5
LT-1826	23.75 X 21	10 X 14	31.75	25.13	27.5
CT-1216	N/A	12 X 16	13	N/A	37
CT-1221	N/A	12 X 21	15	N/A	37
CT-1418	N/A	14 X 18	15	N/A	37
CT-1422	N/A	14 X 22	15	N/A	37
CT-1622	N/A	16 X 22	17.25	N/A	37
CT-1826	N/A	18 X 26	21	N/A	37
CT-2020	N/A	20 X 20	21	N/A	37
T-1014	N/A	10 X 15	23.13	16.75	36
T-1216	N/A	12 X 16	22.75	20.13	36
T-1221	N/A	12 X 21	27.25	20.13	36
T-1418	N/A	14 X 18	24.75	22.13	36
T-1422	N/A	14 X 22	28.75	22.13	36
T-1622	N/A	16 X 22	28.75	24.13	36
T-1826	N/A	18 X 26	32.75	26.13	36
T-2020	N/A	20 X 20	27.75	28.13	36
T2-1014	N/A	10 X 15	27.75	22.13	36
T2-1216	N/A	12 X 16	32.75	24.13	36
T2-1221	N/A	12 X 21	32.75	29.13	36
TT-1014	N/A	10 X 14	21.25	15.25	37.75
TT-1216	N/A	12 X 16	18.25	20.75	37.75
TT-1221	N/A	12 X 22	18.25	26.75	37.75
TT-1418	N/A	14 X 18	20.25	22.75	37.75
TT-1422	N/A	14 X 22	21.25	26.75	37.75
TT-1622	N/A	16 X 22	22.25	26.75	37.75
TT-1826	N/A	18 X 26	24.26	30.75	37.75
TT-2020	N/A	20 X 20	26.25	25.75	37.7
TT2-1014	N/A	10 X 14	21.25	26.75	37.75
TT2-1216	N/A	12 X 16	36.5	20.75	37.75
TT2-1221	N/A	12 X 22	36.5	25.75	37.75
TT2-1418	N/A	14 X 18	40.5	22.75	37.75
TT2-1422	N/A	14 X 22	40.5	26.75	37.75
TT2-1622	N/A	16 X 22	44.5	26.75	37.75
TT2-1826	N/A	18 X 26	48.5	30.75	37.75
TT2-2020	N/A	20 X 20	52.5	25.75	37.75



All dimensions shown in specifications are in inches. For centimeters, multiply by 2.54.

NOTE:



# SPECIFICATIONS

MODEL NUMBER	FLANGE DIAMETER	HEIGHT	CUTOUT DIAMETER	DISH DIAMETER	SHIP WEIGHT
--------------	-----------------	--------	-----------------	---------------	-------------

**DISPOSABLE CUP DISPENSERS**

CD	7.38"	24.5"	5.12"	2.5"-4.63"	—
----	-------	-------	-------	------------	---

**BREAD DISPENSERS**

SB-1	6.63"	6.63"	28"	5.87" X 5.87"	15
------	-------	-------	-----	---------------	----

MODEL NUMBER	L	D	H	CUTOUT DIMENSION	NAPKIN DIMENSIONS	SHIP WEIGHT
--------------	---	---	---	------------------	-------------------	-------------

**NAPKIN DISPENSERS**

ND-45	7.62"	6"	24"	7" X 5.62"	4" X 5.37"	12
ND-47	9.37"	6.25"	24"	8.75" X 5.87"	4.25" X 7.12"	12
ND-48	10.25"	6.25"	24"	9.62" X 6.12"	4.5" X 8"	12
ND-57	9.25"	7.12"	24"	8.62" X 6.75"	5.12" X 7"	12
ND-59	11"	6.75"	24"	10.37" X 6.37"	4.75" X 7.75"	12
ND-67	9.37"	8.17"	24"	8.75" X 8.5"	6.87" X 7.12"	12

MODEL NUMBER	L	D	H	CAPACITY	H.P.	AMP	SHIP WEIGHT
--------------	---	---	---	----------	------	-----	-------------

**MOBILE CHILLED PLATE DISPENSERS**

CP-2	32.5"	28"	36"	100	1/3	10.0	410
CP-4	48"	28"	36"	200	1/3	10.0	485

CP series include a 8" cord with nema 5-15p plug.

**BUILT-IN CHILLED PLATE DISPENSERS**

CPB-2	32"	27.75"	29.63"	100	1/3	10.0	360
CPB-4	47.5"	27.75"	29.63"	200	1/3	10.0	385

CPB series include a 8" cord with nema 5-15p plug.

**MOBILE CHILLED MUG DISPENSERS**

CM-2	48"	28"	36"	60	1/3	10.0	485
------	-----	-----	-----	----	-----	------	-----

CM series include a 8" cord with nema 5-15p plug.

**BUILT-IN CHILLED MUG DISPENSERS**

CMB-2	47.5"	27.5"	29.63"	60	1/3	10.0	385
-------	-------	-------	--------	----	-----	------	-----

CMB series include a 8" cord with nema 5-15p plug.

MODEL NUMBER	L	D	H	CAPACITY	AMP	SHIP WEIGHT
--------------	---	---	---	----------	-----	-------------

**HEATED MOBILE ENCLOSED TRAY AND RACK DISPENSERS**

T-1221H	27.75"	20.12"	36"	12" X 21"	7.0	127
T-1418H	24.75"	22.12"	36"	14" X 18"	7.0	155

T-1221H and T-1418H Includes a 5' cord with nema 5-15p plug.

T-1422H	28.75"	22.12"	36"	14" X 22"	14.0	155
T-1826H	32.75"	26.12"	36"	18" X 26"	14.0	195
T-2020H	27.75"	28.12"	36"	20" X 21"	14.0	185

T-1422H, T-1826H and T-2020H Includes a 5' cord with nema 5-20p plug.

**TWO STACK, HEATED MOBILE ENCLOSED TRAY AND RACK DISPENSERS**

T2-1221H	32.75"	29.12"	36"	12" X 21"	14.0	185
----------	--------	--------	-----	-----------	------	-----

T2-H series include a 5' cord with nema 5-20p plug.

MODEL NUMBER	L	D	H	CUTOUT DIMENSION	MAXIMUM TRAY SIZE	AMP	SHIP WEIGHT
--------------	---	---	---	------------------	-------------------	-----	-------------

**BUILT-IN TRAY AND RACK DISPENSERS**

TG-1014	21.38"	14"	28"	16.88" X 11.5"	10" X 15"	—	120
TG-1216	18.38"	20"	28"	13.88" X 17.5"	12" X 16"	—	128
TG-1221	18.38"	25"	28"	13.88" X 22.5"	12" X 21"	—	137
TG-1418	20.38"	22"	28"	15.88" X 19.5"	14" X 18"	—	128
TG-1422	26"	20.38"	28"	23.5" X 15.88"	14" X 22"	—	121
TG-1622	22.38"	26"	28"	17.88" X 23.5"	16" X 22"	—	152
TG-1826	30"	24.38"	28"	27.5" X 19.88"	18" X 26"	—	164
TG-2020	25"	26.38"	28"	22.5" X 21.88"	20" X 21"	—	159

**TWO STACK BUILT-IN TRAY AND RACK DISPENSERS**

TG2-1014	21.38"	25.63"	28"	16.88" X 23.12"	10" X 15"	—	152
TG2-1216	22.38"	29.63"	28"	17.88" X 27.12"	12" X 16"	—	152
TG2-1221	29.63"	29.38"	28"	27.12" X 22.88"	12" X 21"	—	159

**BUILT-IN HEATED TRAY AND RACK DISPENSERS**

TG-1221H	25"	20.38"	28"	22.5" X 13.88"	12" X 21"	7.0	121
TG-1418H	22"	22.38"	28"	19.5" X 15.88"	14" X 18"	7.0	174
TG-1422H	26"	22.38"	28"	23.5" X 15.88"	14" X 22"	7.0	174
TG-1826H	30"	26.38"	28"	27.5" X 19.88"	18" X 26"	14.0	184
TG-2020H	25"	28.38"	28"	22.5" X 21.88"	20" X 21"	14.0	169

TGH series include a 9" cord with nema 5-15p plug.

**TWO STACK HEATED BUILT-IN TRAY AND RACK DISPENSERS**

TG2-1221H	29.63"	29.38"	28"	27.13" X 22.88"	12" X 21"	7.0	169
-----------	--------	--------	-----	-----------------	-----------	-----	-----

TG2-H unit include a 9" cord with nema 5-15p plug

MODEL NUMBER	L	D	H	MAXIMUM TRAY SIZE	SHIP WEIGHT
--------------	---	---	---	-------------------	-------------

**WALL-MOUNTED CANTILEVER TRAY AND RACK DISPENSERS**

WCT-1216	13"	22.25"	32"	12" X 16"	81
WCT-1221	13"	27.25"	32"	12" X 21"	95
WCT-1418	15"	24.25"	32"	14" X 18"	98
WCT-1422	15"	28.25"	32"	14" X 22"	101
WCT-1622	17.25"	28.25"	32"	16" X 22"	109
WCT-1826	21"	32.25"	32"	18" X 26"	119
WCT-2020	21"	27.25"	32"	20" X 21"	110

MODEL NUMBER	L	D	H	MAXIMUM TRAY SIZE	SHIP WEIGHT
--------------	---	---	---	-------------------	-------------

**TWO STACK, MOBILE OPEN FRAME TRAY AND RACK DISPENSERS**

with silverware bin and napkin dispensers

FT2-SN-1216*	43.75"	22.12"	56.38"	12" X 16"	289
FT2-SN-1418*	47.75"	22.12"	56.38"	14" X 18"	298
FT2-SN-1622*	51.75"	22.12"	56.38"	16" X 22"	306

\*Add 1.75" for each dimension to account for bumpers.



All dimensions shown in specifications are in inches. For centimeters, multiply by 2.54.

## INSTALLATION: DISH DISPENSERS

### Location

Drop-in units require a counter cutout of a specific size for proper fit. Refer to specification data on page three for the proper dimensions.



**Heated units must have minimum 1" (2.5cm) air gap between the bottom of the dispensing tube and any surface or objects below. Make sure the tube will have proper clearance when installing it into a counter or another piece of equipment.**

### Stabilizing

CAB models are supplied with casters for your convenience, for ease of cleaning underneath and mobility.



**The unit must be installed in a stable condition with the front wheels locked. Locking the front casters after installation is the owner's and operator's responsibility.**

### Electrical Connection

All heated DIS and CAB models are tested at the factory to assure proper operation.

Refer to the amperage data on page three, the serial tag, your local or the National Electrical Code to be sure the unit is connected to the proper power source. A protected circuit of the correct voltage and amperage must run for connection of the line cord.

DIS models plug into a wall receptacle when used as drop-in models; if they are grouped together in a CAB model, all of the individual DIS power cords are plugged into the receptacle in the CAB cabinet. The master power cord on CAB models plugs into a wall receptacle.



**The unit must be disconnected from the power source whenever performing service or maintenance functions.**

## INSTALLATION: MOBILE AND BUILT-IN CHILLED PLATE AND MUG DISPENSERS

### Location

For built-in models (CPB & CMB) be sure the location chosen has a floor strong enough to support the total weight of the cabinet and contents. Units in this product line can weigh as much as 1500 pounds when fully loaded. Reinforce the floor as necessary to provide for maximum loading.

Cutout dimensions for CPB-2 and CPB-4 are 13.25" x 23/25"; two cutouts, 2.125" apart are required on the CPB-4.

Cutout dimensions for the CMB-2 are 25.25" x 22.25"

For the most efficient refrigeration, be sure to provide good air circulation inside and out. On the CP and CM mobile units, allow 3.50" clearance for air circulation.

For built in units be sure there is ample air flow from front and rear of unit with ventilation openings equivalent to one square foot of opening.



**Refer to the amperage data on page three, the serial tag, your local or the National Electrical Code to be sure the unit is connected to the proper power source. A protected circuit of the correct voltage and amperage must run for connection of the line cord.**



**The unit must be disconnected from the power source whenever performing service or maintenance functions.**

## INSTALLATION: NAPKIN/CUP DISPENSERS

Napkin and cup units require a counter cutout of a specific size for proper fit. Refer to specification data on page three for the proper dimensions.

# OPERATION DISH DISPENSERS

## Field adjustment

The dispensing height may be adjusted, by following these instructions in order:



**Always wear safety glasses when adjusting your dispenser. Springs under tension may recoil when released.**



**If adjusting a heated model, unplug the unit. Allow the unit to cool completely before handling.**

- 1) Lock brakes on mobile units before beginning.
- 2) Unload the dispenser. Remove dispensers from the unit by grasping the black plastic guide posts and lifting the dispenser completely out of the unit.
- 3) There are minimum of six springs per dispenser. When adjusting, make sure each section has the same number and size of springs connected to the tube and make sure the springs are attached in the same order in each section (see diagram 1). This will prevent the load of dishes from binding.

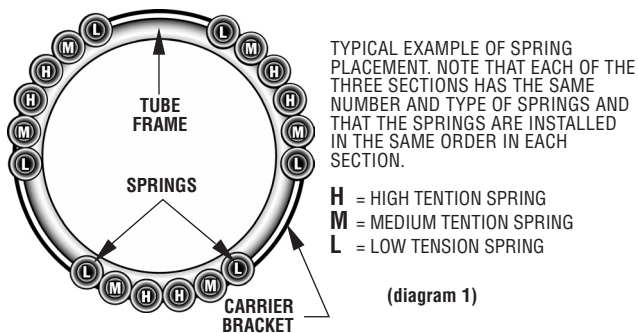

- 4) If the dispensing height is too low, add springs or replace current springs with higher tension springs (springs with higher tension may be ordered from Delfield's Parts and Service Department). Gently engage one spring at a time by hooking the top loop of the spring into the bracket on the tube frame. Then hook the bottom loop of the spring into the carrier bracket (see diagram 2). Add as many springs as necessary.



(diagram 2)  
Dish dispenser spring attachments

- 5) If the dishes are resting too high in the unit, remove springs or replace current springs with lower tension springs (springs with lower tension may be ordered from Delfield's Parts and Service Department). Gently disengage one

spring at a time, unhooking the bottom loop out of the carrier bracket first, the unhooking the top loop from the tube frame. (see diagram 2). Remove as many springs as necessary.

- 6) If level is appropriate, return tube to cart or counter. If spring adjustment does not position carrier properly, repeat procedure trying different springs. If this does not work, a different set of springs may be required. To order call Delfield's Parts and Service Department.

MODEL	SPRING TENSION		
	LIGHT	MEDIUM	HEAVY
DIS-500, 575, 650, 725	3	3	0
DIS-813	3	3	3
DIS-913	3	6	3
DIS-1013	6	6	3
DIS-1200	6	6	6
DIS-1450	6	6	6

## Loading instructions

After adjusting for dispensing height, you are ready to load your dishes.

Only load a manageable stack of dishes at a time — approximately 4" (10.2cm) to 5" (12.7cm). Each DIS model dispensing tube will accommodate a 26" (66cm) stack of plates or bowls.



**Keep fingers clear from the edge of the opening**

If the stack is over the guide posts and is bottomed out, it is full. If stack is over guide posts and not bottomed out (the stack will bounce up and down), adjust the springs. See "Field adjustment" instructions on page eight.

## Temperature adjustment – ET & QT models only

ET (even-temp) models have a 400 watt heating element and an adjustable thermostat. The factory setting for thermostat is "A" which gives an operating temperature of about 165°F (74°C) and effective plate temperatures of between 110°F (43°C) to 120°F (49°C) after about two to three hours of pre-warming.

QT (quick-temp) models have a 700 watt heating element and an adjustable thermostat. The factory setting for thermostat is "E" which gives an operating temperature of about 205°F (96°C) and effective plate temperatures of between 130°F (54°C) to 150°F (66°C) after about two to three hours of pre-warming.

*(Continued on the next page.)*

## OPERATION: DISH DISPENSERS (CONTINUED)

The thermostat is located on the bottom of the unit near the fan motor. Use the following directions to adjust.



**Unplug the unit and allow the unit to cool completely before handling.**

- 1) Lock brakes on mobile units before beginning.
- 2) Unload the dispenser. Remove dispensers from the unit by grasping the black plastic guide posts and lifting the dispenser completely out of the unit. It is not necessary to remove the steel jacket from the dispensing tube.
- 3) Turn the unit on its side.

- 4) Remove filter from bottom of unit. It is not necessary to remove the perforated screen. The screen has access holes in it to allow adjustment of the thermostat. The screen is shown removed in diagram 3 to show the location of the thermostat adjustment screw only.

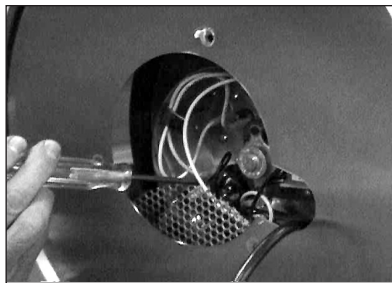

(diagram 3)  
Location of thermostat adjustment screw

- 5) Use a small screw-driver to reach the adjustment screw located under the perforated screen (see diagram 3). Turn the screw to the desired setting based on the "thermostat settings chart" shown below.
- 6) Reattach the filter before operating the unit again.

### Heated Unit Thermostat Settings

Temperature Setting	"A"	"B"	"C"	"D"	"E"
Operating Temperature (°F)	165	175	185	195	205
Operating Temperature (°C)	74	79	85	91	96

# WIRING DIAGRAMS: HEATED DISH DISPENSERS

## DIS, T-H, & TG-H MODELS

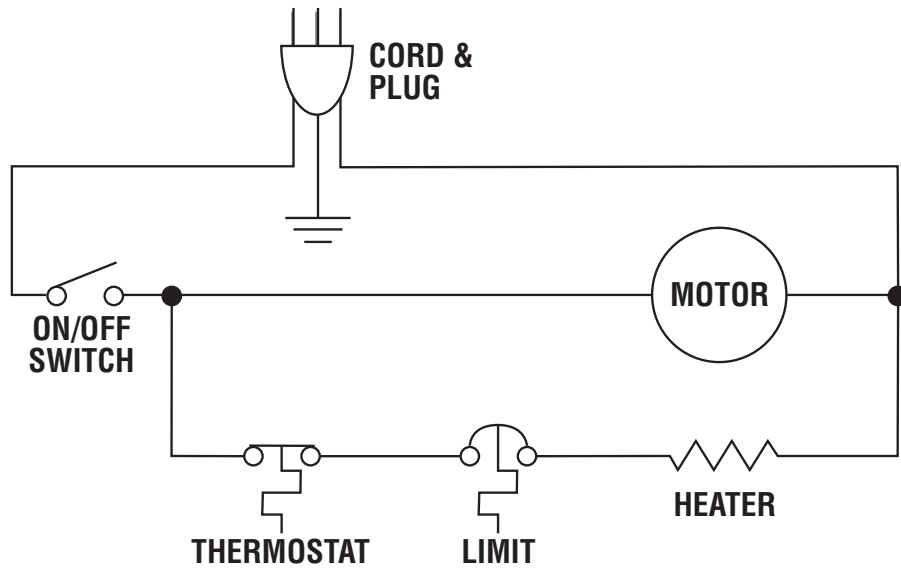

## CAB MODELS

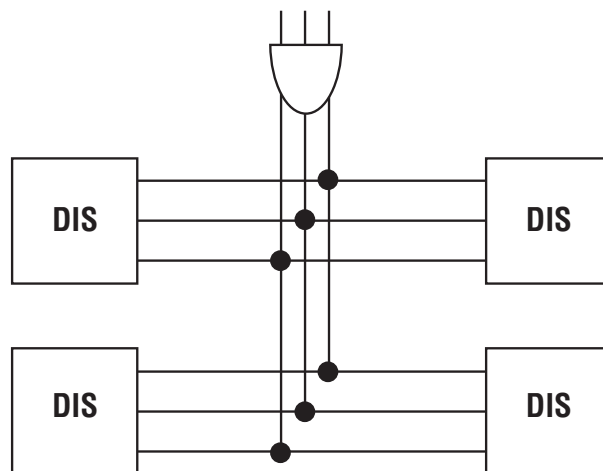

CAB MODELS CONTAIN SEVERAL DIS UNITS WIRED TOGETHER

**WIRING DIAGRAMS: CP, CM, CMB, CPB MODELS DISPENSERS**

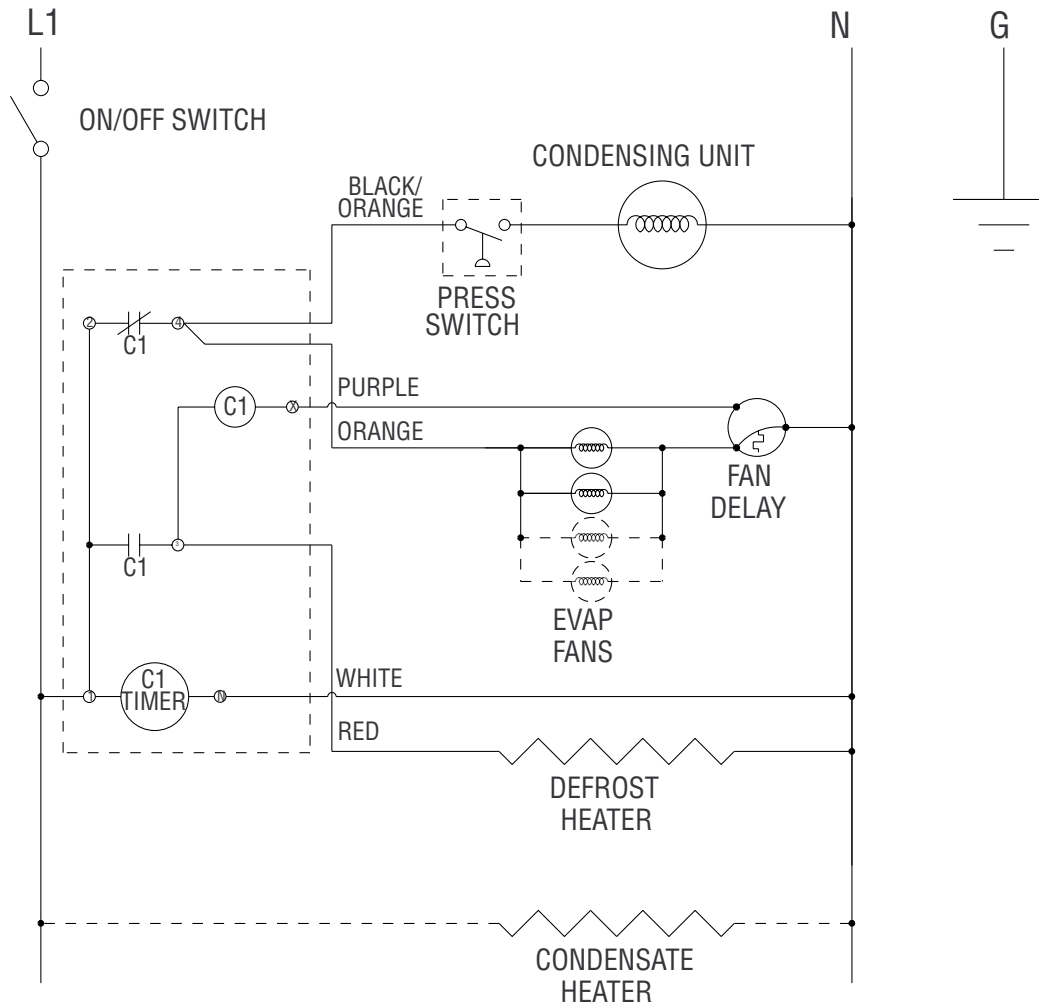

# MAINTENANCE: DISH DISPENSERS

## Unheated dish dispensers

Lift the dispenser out of the counter or CAB cart by grasping the black dish guides and lifting straight up and out. Remove any debris that may be in the assembly with a damp cloth. Clean the stainless steel by using a soft cloth, soap and warm water. If this is not sufficient, try ammonia and water or a non-abrasive liquid cleaner. Rub with the grain of the stainless steel to avoid marring the finish. When cleaning is completed, insert the dispenser assembly back into the counter or CAB cart.

The bottom rails on the CAB cart should be cleaned occasionally. They may be accessed most easily through the bottom of the unit.



**Do not use abrasive cleaner because it will scratch the stainless steel and plastic.**

NOTE:

## Mobile and built in chilled plate and mug dispensers

The interior and exterior can be cleaned using soap and warm water. If this is not sufficient, try ammonia and water or a non-abrasive liquid cleaner. When cleaning the exterior, always rub with the “grain” of the stainless steel to avoid marring the finish. Do not use an abrasive cleaner because it will scratch the stainless steel and plastic.

In order to maintain proper refrigeration performance, the condenser fins must be cleaned of dust, dirt and grease regularly. It is recommended that this be done at least every

three months. If conditions are such that the condenser is totally blocked in three months, the frequency of cleaning should be increased. Clean the condenser with a vacuum cleaner or stiff brush. If extremely dirty, a commercially available condenser cleaner may be required.

## Heated dish dispensers



**Heated units must be disconnected from the main power source and allowed to cool down before cleaning. Cords on DIS models used as drop-ins into a counter or into another piece of equipment are directly connected to the power source. On CAB units there is a cord from each individual DIS tube to a central receptacle on the cart and a separate cord from that receptacle to the main power source. Never hose down units with water.**

Lift the dispenser out of the counter or CAB cart by grasping the black dish guides and lifting straight up and out. Remove any debris that may be in the assembly with a damp cloth. Clean the stainless steel by using a soft cloth, soap and warm water. If this is not sufficient, try ammonia and water or a non-abrasive liquid cleaner. Rub with the grain of the stainless steel to avoid marring the finish. When cleaning is completed, insert the dispenser assembly back into the counter or CAB cart.

The bottom rails on the CAB cart should be cleaned occasionally. They may be accessed most easily through the bottom of the unit.



**Do not use abrasive cleaner because it will scratch the stainless steel and plastic.**

NOTE:

# TROUBLESHOOTING REFERENCE CHART: HEATED DISH DISPENSERS

Problem	Possible Cause	Solutions
<b>No Heat</b>	1) Power cord disconnected 1a) GFCI tripped	Check power source to unit and receptacle at the underside of the cabinet. Reset GFCI receptical position
	2) Disconnected ON/OFF switch or ON/OFF switch in the OFF position	Replace ON/OFF switch; turn ON/OFF switch to on position
	3) Defective heating element	Replace element
	4) Air circulating fan defective or blocked	Replace motor, or remove blockage from fan
<b>Not Hot Enough</b>	1) Unit plugged into incorrect voltage	Check volatge supply and compare to unit's voltage rating
	2) Thermostat set too low	Adjust thermostat to a higher setting
	3) Air circulating fan partially blocked	Remove blockage
	4) Not waiting long enough for pre-heating	90 minutes is a good average pre-heat on DIS models
<b>Too Hot</b>	1) Thermostat set too high	Adjust thermostat to a lower setting
	2) Thermostat defective	Replace Thermostat
<b>Noisy</b>	1) Defective air circulating motor	Replace motor
	2) Obstruction at air circulating motor	Free obstruction
	3) Loose fan blade	Tighten blade

# ADJUSTING SELF-LEVELING DISPENSERS

## Adjusting the self-leveling dispenser



**Tools Needed: One small flat head screw driver;  
One Phillips head screw driver**

NOTE:

1. Always wear safety glasses when adjusting your dispenser. Also, lock brakes on mobile units before beginning.
2. Unload dispenser and remove stainless steel load tray by lifting straight up and set it aside (see fig. 1). For Models LT skip to step #6.

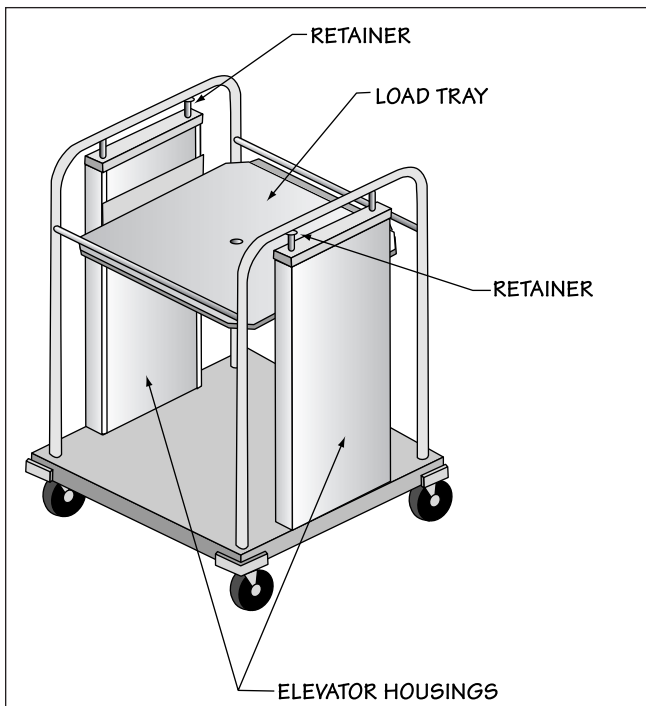

(figure 1) Sample unit

3. Use small regular screw driver to loosen each retainer mounted on stainless steel rod at top of each elevator housing.

4. To remove elevator housing, lift housing straight up to clear the stud on unit base. Then gently swing the bottom of the housing towards the inside of the unit and pull housing out of the unit (see fig. 2). Lay housing on flat surface.



(figure 2) Remove elevator housing

5. Use Phillips head screw driver to remove front panel on the elevator housing (see fig. 3).

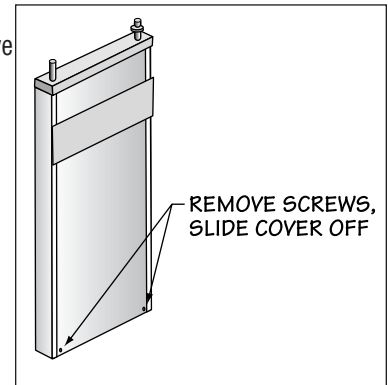

(figure 3) Remove front panel

6. If carrier is riding too high, you need to remove springs. With carrier all the way to the top, gently disengage one spring at a time, unhooking bottom loop out of carrier bracket (see fig. 4). Remove as many springs as necessary.

If carrier is riding too low, you need to add springs. With carrier all the way to the top, gently engage one spring at a time by hooking bottom loop of spring into carrier bracket. Add as many springs as necessary.

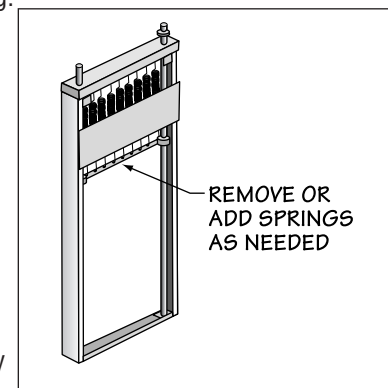

(figure 4) Remove or add springs

7. When finished, put elevator housing back in unit (except on models LT) and put stainless steel load tray back on elevator housings. Load unit to test dispensing level. If spring adjustment does not position carrier properly, repeat procedure #6 trying different springs. If this does not work, a different set of springs may be required. To order, call The Delfield Parts and Service Department.

8. If level is appropriate, put front panels back on and tighten retainer.



**Dispenser should not be operated with front panels off elevator housing.**

**NOTE:** When adjusting the elevators make sure each have the same number and size of springs connected to the carrier on both sides. This will prevent the load tray from binding.

# REPLACEMENT PARTS LIST

## Models T, T2

### 1014 units

0201735	Elevator assembly, small
6150201	Spring, extension, 0.58lbs/in
6230170	Bumper, corner, small pvc
6320257	Bearing, elev, 0.375ID
M3234180	Polyolefin caster 4" with brake
M3234185	Polyolefin caster 4" without brake

### 1216/1222/1418/ 1422/1520/

### 1622/1826/2020 units

0201709	Elevator assembly, large
6150202	Spring, extension, 0.28lbs/in
6230170	Bumper, corner, small pvc
6320257	Bearing, elev, 0.375ID
M3234180	Polyolefin caster 4" with brake
M3234185	Polyolefin Caster 4" without brake

## Models T-H, TG-H

### 1221-H units

0201740	Large elevator
6230007	Bearing
6150201	Extension spring
6150202	Extension spring
0048542	Carrier
0201046	Heat module assy
6190269	Heating element
0047140	Motor housing
0047153	Motor housing screen
6190181	Thermostat
6190180	High limit switch
6160024	Motor
6160007	Fan blade
6190085	Cord/plug
6230314	Air filter

### 1418-H units

3234180	4" Caster
0201046	Heat module assy
6190269	Heating element
0047153	Motor housing screen
6190181	Thermostat
6190180	High limit switch
6160024	Motor
6160007	Fan blade
6190085	Cord/plug
6230314	Air filter
2183347	Cord/plug
6230170	Corner bumper
6230007	Bearing
0047621	Carrier
6150202	Extension spring

### 1422-H units

3234180	4" Caster
0201046	Heat module assy
6190269	Heating element
0047153	Motor housing screen
6190181	Thermostat
6190180	High limit switch
6160024	Motor
6160007	Fan blade
6190085	Cord/plug 18-3
6230314	Air filter

2183347	Cord/plug 14-3
6230170	Corner bumper
0201709	Large elevator assy
6230007	Bearing
0048583	Carrier
6150202	Extension spring

### 1826-H units

3234180	4" caster
0201046	Heat module assy
6190269	Heating element
0047153	Motor housing screen
6190181	Thermostat
6190180	High limit switch
6160024	Motor
6160007	Fan blade
6190085	Cord/plug
6230314	Air filter
2183347	Cord/plug
6230170	Corner bumper
0681855	LT-1826 tray/rack dispenser
0201709	Large elevator assembly
6230007	Bearing
0048584	Carrier
6150202	Extension spring

### 2020-H units

3234180	4" caster
0201046	Heat module assy
6190269	Heating element
0047153	Motor housing screen
6190181	Thermostat
6190180	High limit switch
6160024	Motor
6160007	Fan blade
6190085	Cord/plug 18-3
6230314	Air filter
2183347	Cord/plug 14-3
6230170	Corner bumper
0681811	LT-2020 tray/rack dispenser
0201709	Large elevator assy
6230007	Bearing
0048503	Carrier
6150202	Extension spring

## Models TT, TT2

### 1014 units

0201731	Elevator assembly, small 27.5
6150201	Spring, extension, 0.58lbs/in
6230170	Bumper, corner, small pvc
6230188	Polyolefin caster 4" without brake
6230218	Polyolefin caster 4" with brake
6320257	Bearing, elev, 0.375ID

### 1216/1222/1418/1422/1520/

### 1622/1826/2020 units

0201734	Elevator assembly, large
6150202	Spring, extension, 0.28lbs/in
6230170	Bumper, corner, small pvc
6230188	Polyolefin caster 4" without brake
6230218	Polyolefin caster 4" with brake
6320257	Bearing, elev, 0.375ID

## Models LT, TG, TG2

### 1014 units

0201735	Elevator assembly, small
6150201	Spring, extension, 0.58lbs/in
6320257	Bearing .375ID

### 1216/1222 units

0201709	Elevator assembly, large
6150201	Spring, extension, 0.58lbs/in
6320257	Bearing .375ID

### 1418/1422/1520/1622/1826/2020 units

0201709	Elevator assembly, large
6150202	Spring, extension, 0.28lbs/in
6320257	Bearing .375ID

## Models T2-H, TG2-H

### 1221 units

3234180	4" caster
0201046	Heat module assy
6190269	Heating element
0047153	Motor housing screen
6190181	Thermostat
6190180	High limit switch
6160024	Motor
6160007	Fan blade
6190085	Cord/plug
6230314	Air filter
2183347	Cord/plug
6230170	Corner bumper
0681852	LT2-1221 Tray/Rack Dispenser
0201735	Elevator assy
6230007	Bearing
0048708	Carrier
6150201	Extension spring

## Models DIS

### All units

6230314	Filter, air, 6" diameter (DDS)
6230244	Guide post
6150202	Spring, heavy tension
6150202	Spring, medium tension
6150203	Spring, light tension

### 500 units

6200121	Spinning head
6970011	Wire head

### 575 units

6200122	Spinning head
6970012	Wire head

### 650 units

6200123	Spinning head
6970013	Wire head

### 725 units

6200124	Spinning head
6970014	Wire head

### 813 units

6200125	Spinning head
6970015	Wire head

# REPLACEMENT PARTS LIST

## 913 units

- 6200126 Spinning head
- 6970016 Wire head

## 1013 units

- 6200127 Spinning head
- 6970017 Wire head

## 1200 units

- 6200128 Spinning head
- 6970018 Wire head

## 1450 units

- 6200129 Spinning head
- 6970026 Wire head

## Model DIS-ET, DIS-QT

### All units

- 6230314 Filter, air, 6" diameter
- 6230244 Guide post
- 6150202 Spring, heavy tension
- 6150202 Spring, medium tension
- 6150203 Spring, light tension
- 6190085 Cord with plug, NEMA 5-15P 5'
- 6160024 Motor, 115V 50-60Hz
- 6190180 Switch, high-limit, 245°F
- 2190154 Switch rocker
- 6190181 Thermostat, automatic 165°F - 205°F

### 500/575/650/725 ET units

- 6160008 Fan blade, 3" diameter
- 6190250 Heating element, 120V/327W
- 0201044 Heating module

### 813/913/1013/1200/1450 ET & QT units

- 6160007 Fan blade, 4" diameter (QT models)
- 6160008 Fan blade, 120V/327W (ET models)
- 6190254 Heating element, 120V/327W (ET models)
- 6190269 Heating Element 120V/700W (QT models)
- 0201045 Heating module (ET models)
- 0201046 HTG Module (QT models)

## Model CAB, CAB-ET,

### CAB-QT All units

- 3234180 Caster, 4" with brake (2 needed)
- 3234185 Caster, 4" without brake (2 needed)
- 6230314 Filter, air, 6" diameter
- 6230244 Guide post
- 6150202 Spring, heavy tension
- 6150203 Spring, light tension
- 6190085 Cord with plug, NEMA 5-15P 3'
- 6160024 Motor, 115V 50-60Hz
- 6190180 Switch, high-limit, 245°F
- 2190154 Switch rocker
- 6190181 Thermostat, automatic 165°F - 205°F

### 500/575/650/725 ET units

- 6160008 Fan blade, 3" diameter
- 6190250 Heating element, 120V/327W
- 0201044 Heating module

### 813/913/1013/1200/1450 ET & QT units

- 6160007 Fan blade, 4" diameter (QT models)
- 6160008 Fan blade, 120V/327W (ET models)
- 6190254 Heating element, 120V/327W (ET models)
- 6190269 HTG element, 120V/700W (QT models)
- 0201045 Heating module (ET models)
- 0201046 HTG module (QT models)

### CAB2-ET units

- 2183348 Cord with plug, NEMA 5-15P 6'

### CAB2-QT units

- 2183347 Cord with plug, NEMA 5-20P 6'

### CAB3-ET, CAB4-ET, CAB3-QT, CAB4-QT units

- 6190079 Cord with plug, NEMA 6-20P 6'

## Model SB

- 0201196 Spring head assy
- 6150024 Dish spring
- 0201198 Hinged lid assy

## Model ND

### ND-45

- 0047225 Cover
- 0047226 Head
- 6150203 Extension spring

### ND-47

- 0047127 Cover
- 0047152 Head
- 6150203 Extension spring

### ND-48

- 0047227 Cover
- 0047229 Head
- 6150203 Extension spring

### ND-57

- 0047239 Cover
- 0047241 Head
- 6150203 Extension spring

### ND-59

- 0047237 Cover
- 0047247 Head
- 6150203 Extension spring

### ND-47

- 0047250 Cover
- 0047251 Head
- 6150203 Extension spring

## Model CP - mobile and built in

- 3234180 4" caster
- 6230019 Aluminum hinge
- 9321122 Snap bushing 1.50 black
- 9321198 Bushing 1.00 snap
- 3516070 Low temp cooler
- 3516225 Expansion valve
- 3526710 Condensing unit
- 3516101 Filter dryer
- 2193927 Pressure control

- 0100049 Electric condensate evap. pan
- 2194199 Heating element
- 2194151 Paragon timer
- 6700027 Throat collar
- 6230186 Snap in w/screen vent
- 6200068 Spinning head
- 6230233 Spring head adjustment
- 6150077 Spring compression
- 0201603 Lid assy
- 6230109 Extruded hinge
- 6230110 Plastic insert hinge
- 3234110 Lift cover chrome handle
- 2214110003 Louver 13.00 x 25.00
- 0047033 Side louver 13.00 x 13.50
- 0048864 Side louver 9.00 x 13.50
- 2190154 Rocker switch
- 6230172 Corner bumper
- 2183348 Cord/plug

## Model CM - mobile and built in

- 3516070 Unit cooler
- 3516225 Expansion valve
- 3234180 4" caster
- 9321122 Bushing 1.50 black
- 9321198 Bushing 1.00 snap
- 3526710 Condensing unit
- 3516101 Filter dryer
- 2193927 Pressure control
- 0100049 Electric condensate evap. pan
- 2194199 Heating element
- 2194151 Paragon timer
- 0044074 Throat collar
- 0201737 Large elevator assy
- 6320007 Bearing .50
- 6150201 Extension spring .58
- 6150202 Extension spring .28
- 6230024 Retainer
- 0047745 Carrier
- 0201525 Lid assy
- 6230109 Extruded hinge
- 6230110 Plastic insert hinge
- 3234110 Lift cover chrome handle
- 2214110003 Louver 13.00 x 25.00
- 0047033 Side louver 13.00 x 13.50
- 0048864 Side louver 9.00 x 13.50
- 2190154 Rocker switch
- 6230172 Corner bumper
- 2183348 Cord/plug

## Model CT - WCT Series

- 6230170 Small bumper corner
- 3234180 4" caster (CT series only)
- 6230068 Bearing
- 6150206 Extension spring

In addition to the above parts

### CT/WCT-1216

- 0047481 Carrier 12.50 x 16.50

### CT/WCT-1221

- 0047486 Carrier 12.50 x 21.50

### CT/WCT-1418

- 0047490 Carrier 14.56 x 18.56

### CT/WCT-1422

- 0047491 Carrier 14.50 x 22.50



## REPLACEMENT PARTS LIST

### CT/WCT-1622

0047496 Carrier 16.56 x 22.56

### CT-1821 and WCT-2020

0047499 Carrier 20.56 x 21.56

### CT/WCT-1826

0047498 Carrier 18.56 x 26.56

## Model FT2-SN

### All units

6230170 Corner bumper  
6230218 4" caster  
0201734 Large elevator  
6320007 Bearing  
6150201 Extension spring .58  
6150202 Extension spring .28  
6230024 Retainer  
0680934 ND-napkin dispenser  
6150203 Extension spring .16  
0047241 Head ND-57  
0047239 Cover ND-57  
3234052 Silverware container

In addition to the above parts

### FT2-SN-1216

0048492 Carrier 1216

### FT2-SN-1418

0047621 Carrier 1418

### FT2-SN-1622

0047568 Carrier 1622

**STANDARD LABOR GUIDELINES TO REPAIR OR REPLACE PARTS ON DELFIELD EQUIPMENT**

Advice and recommendations given by Delfield Service Technicians do not constitute or guarantee any special coverage.

- A maximum of 1-hour is allowed to **diagnose a defective component**.
- A maximum of 1-hour is allowed for **retrieval of parts** not in stock.
- A maximum **travel distance** of 100 miles round trip and 2-hours will be reimbursed.
- Overtime, installation/start-up, normal control adjustments, general maintenance, glass breakage, freight damage, and/or correcting and end-user installation error will not be reimbursed under warranty unless pre-approved with a **Service Work Authorization** from Delfield. You must submit the number with the service claim.

**LABOR OF 1-HOUR IS ALLOWED TO REPLACE:**

- Thermostat
- Infinite Switch
- Door Jamb Switch
- Solenoid Coil
- Hi-limit/Thermal Protector Switch
- Fan Delay/Defrost Termination Switch
- Compressor Start Components and Overload Protector
- Defrost Timer
- Thermometer
- Gear Box
- Contactor/Relay
- Transformer
- Evaporator/Condenser Fan Motor and Blade
- Circulating Fan Motor and Blade
- Microprocessor Control
- Water Level Sensor/Probe
- Door Hinges, Locks, and Gaskets
- Condensate Element
- Springs/Lowerator

**LABOR OF 2 HOURS TO REPLACE:**

- Drawer Tracks/Cartridges
- Pressure Control
- Solenoid Valve
- Defrost Element
- Heating Element
- Locate/Repair Leak

**LABOR OF 3 HOURS TO REPLACE:**

- EPR or CPR Valve
- Expansion Valve
- Condenser or Evaporator Coil

**LABOR OF 4 HOURS TO REPLACE**

- Compressor

This includes recovery of refrigerant and leak check.

\$35.00 maximum reimbursement for refrigerant recovery (includes recovery machine, pump, torch, oil, flux, minor fittings, solder, brazing rod, nitrogen, or similar fees.)

**REFRIGERANTS**

- R22 A maximum of \$4.00/lb. or 25¢/oz. will be reimbursed.
- R134A A maximum of \$5.00/lb. or 31¢/oz. will be reimbursed.
- R404A A maximum of \$12.00/lb. or 75¢/oz. will be reimbursed.



### **STANDARD ONE YEAR WARRANTY** (ONE YEAR PARTS, 90 DAYS LABOR.)

The Delfield Company ("Delfield") warrants to the Original Purchaser of the Delfield product (herein called the "Unit") that such Unit, and all parts thereof, will be free from defects in material and workmanship under normal use and service for a period of one (1) year from the date of shipment of the Unit to the Original Purchaser **or, if the Original Purchaser returns the warranty card completely filled out including the date of installation within thirty (30) days of receipt of the Unit, one (1) year from the date of installation.** During this one year warranty period, Delfield will repair or replace any defective part or portion thereof returned to Delfield by the Original Purchaser which Delfield determines was defective due to faulty material or workmanship. The Original purchaser will pay all labor, crating, freight and related costs incurred in the removal of the Unit of defective component and shipment to Delfield, except that during a period of either ninety (90) days from the date of shipment of the Unit to the Original Purchaser or, if the Original Purchaser returns the warranty card completely filled out including the date of installation within thirty (30) days of receipt of the Unit, ninety (90) days from the date of installation Delfield will pay all related labor costs. Delfield will pay the return costs if the Unit or part thereof was defective.

The term "Original Purchaser" as used herein means that person, firm, association, or corporation for whom the Unit was originally installed.

This warranty does not apply to any Unit or part thereof that has been subjected to misuse, neglect, alteration, or accident, such as accidental damage to the exterior finish, operated contrary to the recommendations specified by Delfield; or repaired or altered by anyone other than Delfield in any way so as to, in Delfield's sole judgement, affect its quality or efficiency. This warranty does not apply to any Unit that has been moved from the location where it was originally installed. This warranty also does not cover the refrigerator drier or the light bulbs used in the Unit. **The warranty is subject to the user's normal maintenance and care responsibility as set forth in the Service and Installation Manual, such as cleaning the condenser coil, and is in lieu of all other obligations of Delfield. Delfield neither assumes, nor authorizes any other person to assume for Delfield, any other liability in connection with Delfield's products.**

Removal or defacement of the original Serial Number or Model Number from any Unit shall be deemed to release Delfield from all obligations hereunder or any other obligations, express or implied.

Parts furnished by suppliers to Delfield are guaranteed by Delfield only to the extent of the original manufacturer's express warranty to Delfield. Failure of the Original Purchaser to receive such manufacturer's express warranty to Delfield. Failure of the Original Purchaser to receive such manufacturer's warranty shall in no way create any warranty, expressed or implied, or any other obligation or liability on Delfield's part in respect thereof.

**IF THE CUSTOMER IS USING A PART THAT RESULTS IN A VOIDED WARRANTY AND A DELFIELD AUTHORIZED REPRESENTATIVE TRAVELS TO THE INSTALLATION ADDRESS TO PERFORM WARRANTY SERVICE, THE SERVICE REPRESENTATIVE WILL ADVISE CUSTOMER THE WARRANTY IS VOID. SUCH SERVICE CALLS WILL BE BILLED TO CUSTOMER AT THE AUTHORIZED SERVICE CENTER'S THEN APPLICABLE TIME AND MATERIALS RATES. CONSIDER: CUSTOMER MAY INITIATE A SERVICE AGREEMENT WITHOUT PARTS COVERAGE.**

If shipment of a replacement part is requested prior to the arrival in the Delfield factory of the part claimed to be defective, the Original Purchaser must accept delivery of the replacement part of a C.O.D.

basis, with credit being issued after the part has been received and inspected at Delfield's plant and determined by Delfield to be within this warranty.

Under no condition does this warranty give the Original Purchaser the right to replace the defective Unit with a complete Unit of the same manufacturer or of another make. Unless authorized by Delfield in writing, this warranty does not permit the replacement of any part, including the motor-compressor, to be made with the part of another make or manufacturer.

No claims can be made under this warranty for spoilage of any products for any reason, including system failure.

The installation contractor shall be responsible for building access, entrance and field conditions to insure sufficient clearance to allow any hood(s), vent(s), or Unit(s) if necessary, to be brought into the building. Delfield will not be responsible for structural changes or damages incurred during installation of the Unit or any exhaust system.

Delfield shall not be liable in any manner for any default or delay in performance hereunder caused by or resulting from any contingency beyond Delfield's control, including, but not limited to, war, governmental restrictions or restraints, strike, lockouts, injunctions, fire, flood, acts of nature, short or reduced supply of raw materials, or discontinuance of the parts by the original part manufacturer.

**Except as provided in any Additional Four Year Protection Plan, if applicable, and the Service Labor Contract, if applicable, the foregoing is exclusive and in lieu of all other warranties, whether written or oral, express or implied. This warranty supersedes and excludes any prior oral or written representations or warranties. Delfield expressly disclaims any implied warranties of merchantability, fitness for a particular purpose of compliance with any law, treaty, rule or regulation relating to the discharge of substances into the environment. The sole and exclusive remedies of any person relating to the Unit, and the full liability of Delfield for any breach of this warranty, will be as provided in this warranty.**

Other than this Delfield Standard One Year Limited Warranty, any applicable Delfield Additional Four Year Protection Plan or applicable Delfield Service Labor Contract, the Original Purchaser agrees and acknowledges that no other warranties are offered or provided in connection with or for the unit or any other part thereof.

In no event will Delfield be liable for special, incidental or consequential damages, or for damages in the nature of penalties.

**IF DURING THE WARRANTY PERIOD, CUSTOMER USES A PART FOR THIS DELFIELD EQUIPMENT OTHER THAN AN UNMODIFIED NEW OR RECYCLED PART PURCHASED DIRECTLY FROM DELFIELD OR ANY OF ITS AUTHORIZED SERVICE CENTERS AND/OR THE PART BEING USED IS MODIFIED FROM ITS ORIGINAL CONFIGURATION, THIS WARRANTY WILL BE VOID. FURTHER, DELFIELD AND ITS AFFILIATES WILL NOT BE LIABLE FOR ANY CLAIMS DAMAGES OR EXPENSES INCURRED BY THE CUSTOMER WHICH ARISE DIRECTLY OR INDIRECTLY, IN WHOLE OR IN PART, DUE TO THE INSTALLATION OF ANY MODIFIED PART AND/OR PART RECEIVED FROM AN UNAUTHORIZED SERVICE CENTER. If the warranty becomes void, Customer may purchase from Delfield, if available, a Service Agreement or service at the then current time and materials rate.**

For more information on Delfield warranty's log on and check out the service section of our web site at [www.delfield.com](http://www.delfield.com).

**ADDITIONAL FOUR YEAR PROTECTION PLAN** (FOR MOTOR-COMPRESSOR ONLY)

Delfield Model#	Serial #	Installation Date

In addition to the Standard One Year Warranty on the Motor-Compressor contained in the above listed Delfield product (the "Unit"), The Delfield Company ("Delfield") also agrees to repair, or exchange with similar or interchangeable parts in design and capacity at Delfield's option, the defective Motor-Compressor contained in the Unit (the "Motor-Compressor"), or any part thereof, for the Original Purchaser only, at any time during the four (4) years following the initial one (1) year period commencing on the date of installation for the Original Purchaser. **Failure of the Original Purchaser to register the registration card containing the Original Purchasers name, address, date of installation, model number and serial number of the Unit containing the Motor-Compressor within 30 days from the date of installation shall void this warranty.** This additional warranty is only available if the Motor-Compressor is inoperative due to defects in material or factory workmanship, as determined by Delfield in its sole judgement and discretion. The Original Purchaser shall be responsible for returning the defective Motor-Compressor to Delfield prepaid, F.O.B. at the address shown on the back cover of this manual.

The term "Original Purchaser" as used herein means that person, firm, association, or corporation for whom the Unit was originally installed.

The term "Motor-Compressor" as used herein does not include unit base, air or water cooled condenser, receiver, electrical accessories such as relay, capacitors, refrigerant controls, or condenser fan/motor assembly. This warranty does not cover labor charges incidental to the replacement of parts. This warranty further does not include any equipment to which said condensing unit is connected, such as cooling coils, temperature controls or refrigerant metering devices. This warranty shall be void if the Motor-Compressor, in Delfield's sole judgement, has been subjected to misuse, neglect, alteration or accident, operated contrary to the recommendations specified by the Unit manufacturer, repaired or altered by anyone other than Delfield in any way so as, in Delfield's sole judgment, to affect its quality or efficiency or if the serial number has been altered, defaced or removed. This Warranty does not apply to a Motor-Compressor in any Unit that has been moved from the location where it was originally installed. The addition of methyl chloride to the condensing unit or refrigeration system shall void this warranty.

**General Conditions**

Delfield shall not be liable in any manner for any default or delay in performance hereunder caused by or resulting from any contingency beyond Delfield's control, including, but not limited to, war, governmental restrictions or restraints, strike, lockouts, injunctions, fire, flood, acts of nature, short or reduced supply of raw materials, or discontinuance of any part or the Motor-Compressor by the unit manufacturer.

Replacement of a defective Motor-Compressor is limited to one (1) Motor-Compressor by us during the four (4) year period. Delfield shall replace the Motor-Compressor at no charge.

This warranty does not give the Original Purchaser of the Motor-Compressor the right to purchase a complete replacement Motor-Compressor of the same make or of another make. It further does not permit the replacement to be made with a Motor-Compressor of another kind unless authorized by Delfield. In the event Delfield authorizes the Original Purchaser to purchase a replacement Motor-Compressor locally, only the wholesale cost of the Motor-Compressor is refundable.

Expressly excluded from this warranty are damages resulting from spoilage of goods.

**Except as provided in any applicable Standard One Year Limited Warranty or applicable Service Labor Contract, the foregoing is exclusive and in lieu of all other warranties, whether written or oral, express or implied. This Warranty supersedes and excludes any prior oral or written representations or warranties. Delfield expressly disclaims any implied warranties of merchantability, fitness for a particular purpose or compliance with any law, treaty, rule or regulation relating to the Motor-Compressor, and the full liability of Delfield for any breach of this warranty, will be as provided in this warranty.**

Other than any applicable Delfield Standard One year Limited Warranty, this Delfield Additional Four Year Protection Plan and any applicable Delfield Service Labor Contract, the Original Purchaser agrees and acknowledges that no other warranties are offered or provided in connection with or for the Motor-Compressor or any part thereof.

In no event will Delfield be liable for special, incidental or consequential damages, or for damages in the nature of penalties.



# AUTHORIZED PARTS DEPOTS

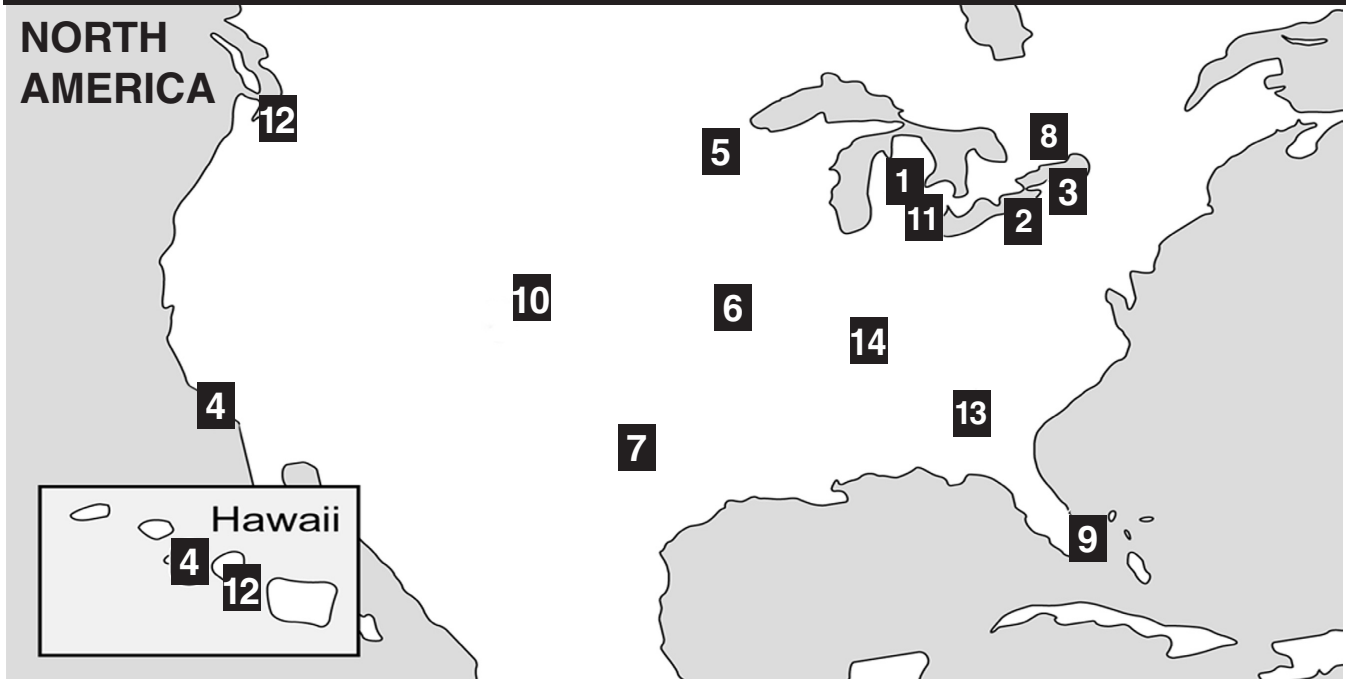

<p><b>1) The Delfield Company</b></p> <p>980 South Isabella Road Mt. Pleasant, MI 48858 800.733.8829 989.773.7981 989.773.3210 FAX custom parts direct from Delfield</p>	<p><b>2) A.I.S. Commercial Parts &amp; Service</b></p> <p>1816 West 26th Street Erie, PA 16508-1149 800.332.3732 814.456.3732 814.452.4843 FAX serves: MD, NJ, OH, PA, VA, WV</p>	<p><b>3) Appliance Installation Service</b></p> <p>1336 Main Street Buffalo, NY 14209 800.722.1252 716.884.7425 716.884.0410 FAX serves: CT, DC, DE, MA, MD, ME, NH, NJ, NY, PA, RI, VA, VT, WV</p>	<p><b>4) Pacific Coast Parts</b></p> <p>15024 Staff Court Gardena, CA 90248 1.800.531.1111 1.800.782.5747 Email: orders@pacparts.com www.pacparts.com serves: AZ, CA, HI, NV, OR</p>
<p><b>5) Contract Ice</b></p> <p>14450 Ewing Ave S. #100 Burnsville, MN 55306 800.422.2823 952.894.4427 952.894.2164 FAX serves: IA, MN, MT, ND, SD, WI</p>	<p><b>6) E.M.C.O. Sales &amp; Distributors</b></p> <p>3909 St. Timothy Lane St. Ann, MO 63074 800.972.7670 314.427.7477 314.427.8190 FAX serves: AR, IA, IL, KS, KY, MO, NE, OK, TX, NM, LA</p>	<p><b>7) Stove Parts Supply/GCS Service</b></p> <p>2120 Solona St. PO Box 14009 Fort Worth, TX 76117-0009 1.800.433.1804 toll free 1.800.272.7358 fax serves: AR, LA, NM, OK, TX</p>	<p><b>8) Garland Group</b></p> <p>1177 Kamato Road Mississauga, Ontario L4W1X4 800.427.6668 800.361.7745 FAX serves: Canada</p>
<p><b>9) Global Parts and Supplies</b></p> <p>2920 N.W. 109th Avenue Miami, FL 33172 305.994.9994 305.994.9992 FAX International parts depot</p>	<p><b>10) Hawkins Commercial Appl. Serv.</b></p> <p>3000 S. Wyandot Englewood, CO 80110 (800) 624-2117 (303) 7618861 FAX serves: AZ, CO, KS, NE, NM, OK, UT, WY</p>	<p><b>11) MicroDine, Inc.</b></p> <p>44792 Helm Plymouth, MI 48170 888.828.4454 734.451.2043 734.451.3215 FAX serves: MI, IN, WI, OH</p>	<p><b>12) Performance Refrigeration Parts</b></p> <p>9923 S.W. 178th St. Vashon, WA 98070 888.872.2465 206-463-1772 206.463.4431 FAX serves: AK, HI, ID, MT, OR, WA</p>
<p><b>13) Southeastern Restaurant Services</b></p> <p>2200 Norcross Parkway, Suite 210 Atlanta, GA 30071 800.235.6516 770.446.6177 770.446.3157 FAX serves: FL, GA, MS, NC, SC, VA</p>	<p><b>14) T.M.A.</b></p> <p>2916 Sidco Drive Nashville, TN 37204 615.726.0351 800.737.0351 615.259.4100 FAX serves: TN, AL</p>	<p><b>Delfield has 14 conveniently located Parts Depots to ensure parts are handled promptly and accurately.</b></p> <p>Delfield reserves the right to update or make changes to this list without prior notice</p> <p>Please call 1-800-733-8829 or check the web at <a href="http://www.delfield.com">www.delfield.com</a> for a list of the current Parts Depots.</p>	



980 S. Isabella Rd., Mt. Pleasant, MI 48804-0470, U.S.A. • (989) 773-7981 or (800) 733-8821 • Fax (800) 669-0619 • [www.delfield.com](http://www.delfield.com)  
Delfield reserves the right to make changes in design or specifications without prior notice. ©2003 The Delfield Company. All rights reserved. Printed in the U.S.A.