

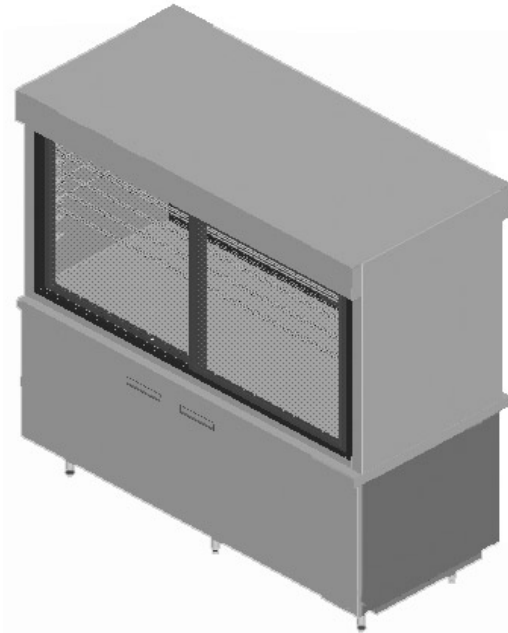

F5 and F15 Series

Service and Installation Manual

Please read this manual completely before attempting to install or operate this equipment!
Notify carrier of damage! Inspect all components immediately. See page 2.



F5 and F15 SERIES
Drop In and Servview Display Cases

 **IMPORTANT INFORMATION**
READ BEFORE USE
PLEASE SAVE THESE INSTRUCTIONS!

Effective Date January 2004

CONTENTS

RECEIVING & INSPECTING EQUIPMENT.....2
 SPECIFICATIONS 3-4
 INSTALLATION
 F15 Series.....5
 F5 Series.....5
 CONDENSER AIR FLOW
 Models F5 — 48” units6
 Models F5 — 72” units7
 OPERATION8
 PRESSURE CONTROL SETTINGS.....8
 INSTALLATION
 F5 Remote9
 F15 Remote9

ROUTINE MAINTENANCE10
 SLIDING DOOR ASSEMBLY MAINTENANCE.....10
 PIKE DOOR COMPONENTS LIST11
 CONDENSING UNIT ASSEMBLY12
 DOOR ASSEMBLY — SERVICE CASES13
 FLUORESCENT FIXTURE13
 COIL ASSEMBLY.....14
 REPLACEMENT PARTS LISTS15
 WIRING DIAGRAM.....16
 TROUBLESHOOTING REFERENCE CHART.....17
 STANDARD WARRANTIES..... 18-19
 AUTHORIZED PARTS DEPOTS..... back cover

SERIAL NUMBER LOCATION

The serial number on all self-contained F5 Series units is located near the condensing unit. On all remote F5 Series units the serial number is located on the drop-in frame.

The serial number on all self-contained F15 Series units is located behind the louver covering the compressor section of the base, near the condensing unit. On all remote F15 Series units the serial number is located behind the six inch panel in the base.

Always have the serial number of your unit available when calling for parts or service. A complete list of authorized Delfield parts depots is shown on the back cover of this manual.

©2004 The Delfield Company. All rights reserved. Reproduction without written permission is prohibited.

SERIAL #
MODEL #
INSTALLATION DATE:

RECEIVING AND INSPECTING THE EQUIPMENT

Even though most equipment is shipped crated, care should be taken during unloading so the equipment is not damaged while being moved into the building.

1. Visually inspect the exterior of the package and skid or container. Any damage should be noted and reported to the delivering carrier immediately.
2. If damaged, open and inspect the contents with the carrier.
3. In the event that the exterior is not damaged, yet upon opening, there is concealed damage to the equipment notify the carrier. Notification should be made verbally as well as in written form.
4. Request an inspection by the shipping company of the damaged equipment. This should be done within 10 days from receipt of the equipment.
5. Check the lower portion of the unit to be sure legs or casters are not bent.

6. Also open the compressor compartment housing and visually inspect the refrigeration package. Be sure lines are secure and base is still intact.
7. Freight carriers can supply the necessary damage forms upon request.
8. Retain all crating material until an inspection has been made or waived.

Uncrating the Equipment

First cut and remove the banding from around the crate. Remove the front of the crate material, use of some tools will be required. If the unit is on legs remove the top of the crate as well and lift the unit off the skid. If the unit is on casters it can be "rolled" off the skid.

F5 SERIES SPECIFICATIONS

MODEL NUMBER	H.P.*	VOLTS/HERTZ PHASE	AMPS	EVAPORATOR CAPACITY BTU/°TD	CABINET LOAD BTU/HOUR
24" (61cm) Deep Remote Drop-In Refrigerated Display Cases					
F5MR48N	1/2*	115/60/1	4.0	150	1150
F5SR48N	1/2*	115/60/1	4.0	150	1802
F5PR48N	1/2*	115/60/1	4.0	150	1880
F5MR72N	3/4*	115/60/1	4.0	450	1700
F5SR72N	3/4*	115/60/1	4.0	450	2708
F5PR72N	3/4*	115/60/1	4.0	450	2801

*Recommended horsepower

MODEL NUMBER	H.P.	VOLTS/HERTZ PHASE	AMPS	SYSTEM CAPACITY BTU/HOUR	CABINET LOAD BTU/HOUR	NEMA PLUG
24" (61cm) Deep Self-Contained Drop-In Refrigerated Display Cases						
F5MC48N	1/2	115/60/1	12.0	3160	1150	5-15P
F5SC48N	1/2	115/60/1	12.0	3160	1802	5-15P
F5PC48N	1/2	115/60/1	12.0	3160	1880	5-15P
F5MC72N	3/4	115/60/1	16.0	5758	1700	5-20P
F5SC72N	3/4	115/60/1	16.0	5758	2708	5-20P
F5PC72N	3/4	115/60/1	16.0	5758	2801	5-20P

MODEL NUMBER	H.P.*	VOLTS/HERTZ PHASE	AMPS	EVAPORATOR CAPACITY BTU/°TD	CABINET LOAD BTU/HOUR
30" (76.2cm) Deep Remote Drop-In Refrigerated Display Cases					
F5MR48D	1/2*	115/60/1	4.0	150	1215
F5SR48D	1/2*	115/60/1	4.0	150	1867
F5PR48D	1/2*	115/60/1	4.0	150	1945
F5MR72D	3/4*	115/60/1	4.0	450	1783
F5SR72D	3/4*	115/60/1	4.0	450	2791
F5PR72D	3/4*	115/60/1	4.0	450	2884

*Recommended horsepower

MODEL NUMBER	H.P.	VOLTS/HERTZ PHASE	AMPS	SYSTEM CAPACITY BTU/HOUR	CABINET LOAD BTU/HOUR	NEMA PLUG
30" (76.2cm) Deep Self-Contained Drop-In Refrigerated Display Cases						
F5MC48D	1/2	115/60/1	12.0	3160	1215	5-15P
F5SC48D	1/2	115/60/1	12.0	3160	1867	5-15P
F5PC48D	1/2	115/60/1	12.0	3160	1945	5-15P
F5MC72D	3/4	115/60/1	16.0	5758	1783	5-20P
F5SC72D	3/4	115/60/1	16.0	5758	2791	5-20P
F5PC72D	3/4	115/60/1	16.0	5758	2884	5-20P

M = Mirror Back • **P** = Pass Thru • **S** = See Thru • **R** = Remote • **C** = Self-Contained • **N** = Narrow • **D** = Deep 30"



F15 SERIES SPECIFICATIONS

MODEL NUMBER	H.P.*	VOLTS/HERTZ PHASE	AMPS	EVAPORATOR CAPACITY BTU/°TD	CABINET LOAD BTU/HOUR
24" (61cm) Deep Remote Serview Refrigerated Display Cases					
F15MR48N	3/4*	115/60/1	4.0	320	1579
F15SR48N	3/4*	115/60/1	4.0	320	2231
F15PR48N	3/4*	115/60/1	4.0	320	2309
F15MR72N	3/4*	115/60/1	4.0	570	2408
F15SR72N	3/4*	115/60/1	4.0	570	3416
F15PR72N	3/4*	115/60/1	4.0	570	3509

*Recommended horsepower

MODEL NUMBER	H.P.	VOLTS/HERTZ PHASE	AMPS	SYSTEM CAPACITY BTU/HOUR	CABINET LOAD BTU/HOUR	NEMA PLUG
24" (61cm) Deep Self-Contained Serview Refrigerated Display Cases						
F15MC48N	3/4	115/60/1	16.0	4978	1504	5-20P
F15SC48N	3/4	115/60/1	16.0	4978	2156	5-20P
F15PC48N	3/4	115/60/1	16.0	4978	2234	5-20P
F15MC72N	3/4	115/60/1	16.0	5758	2278	5-20P
F15SC72N	3/4	115/60/1	16.0	5758	3286	5-20P
F15PC72N	3/4	115/60/1	16.0	5758	3379	5-20P

MODEL NUMBER	H.P.*	VOLTS/HERTZ PHASE	AMPS	EVAPORATOR CAPACITY BTU/°TD	CABINET LOAD BTU/HOUR
30" (76.2cm) Deep Remote Serview Refrigerated Display Cases					
F15MR48D	3/4*	115/60/1	4.0	320	1644
F15SR48D	3/4*	115/60/1	4.0	320	2296
F15PR48D	3/4*	115/60/1	4.0	320	2374
F15MR72D	3/4*	115/60/1	4.0	570	2491
F15SR72D	3/4*	115/60/1	4.0	570	3499
F15PR72D	3/4*	115/60/1	4.0	570	3592

*Recommended horsepower

MODEL NUMBER	H.P.	VOLTS/HERTZ PHASE	AMPS	SYSTEM CAPACITY BTU/HOUR	CABINET LOAD BTU/HOUR	NEMA PLUG
30" (76.2cm) Deep Self-Contained Serview Refrigerated Display Cases						
F15MC48D	3/4	115/60/1	16.0	4978	1569	5-20P
F15SC48D	3/4	115/60/1	16.0	4978	2221	5-20P
F15PC48D	3/4	115/60/1	16.0	4978	2299	5-20P
F15MC72D	3/4	115/60/1	16.0	5758	2361	5-20P
F15SC72D	3/4	115/60/1	16.0	5758	3369	5-20P
F15PC72D	3/4	115/60/1	16.0	5758	3462	5-20P

M = Mirror Back • P = Pass Thru • S = See Thru • R = Remote • C = Self-Contained • N = Narrow 24" • D = Deep 30"



INSTALLATION: SELF-CONTAINED F15 SERIES

Location

Units represented in this manual are for indoor use only. Be sure the location chosen has a floor strong enough to support the total weight of the cabinet and contents. A fully loaded model may weigh as much as 3000 pounds! Reinforce the floor as necessary to provide for maximum loading.

For the most efficient refrigeration, be sure to provide good air circulation inside and out. Don't pack the refrigerator so full that air cannot circulate. Be sure that the exterior of the unit has access to ample air. Avoid hot corners and locations near stoves and ovens.



Do not install the unit near any combustible material or object affected by heat or moisture.

Unit is designed to maintain 36°F (2°C) to 40°F (4°C) interior cabinet temperature at 65% or lower ambient relative humidity

Leveling

A level cabinet looks better and will perform better because the drain pan will drain properly, the doors will line up with the frames properly, and the cabinet will not be subject to undue strain.

Plumbing

Self-contained models are standard with a condensate evaporator. If your unit does not have a condensate evaporator, or the evaporator fails, the unit's drain must have an outlet to an appropriate drainage area or container.



Moisture collecting from improper drainage can create a slippery surface on the floor and a hazard to employees. It is the owner's and operator's responsibility to provide a container or outlet for drainage.

Electrical connection

Refer to the amperage data on pages 3-4, the serial tag, your local code or the National Electrical Code to be sure the unit is connected to the proper power source. A protected circuit of the correct voltage and amperage must be run for connection of the line cord, or permanent connection to the unit.

Self-contained units have an **ON/OFF** switch located directly behind the louvered panel covering the compressor section. Simply turn the switch to **ON** to begin operation.



The power switch should be turned to OFF and the unit disconnected from the power source whenever performing service or maintenance functions.

INSTALLATION: SELF-CONTAINED F5 SERIES

Units represented in this manual are for indoor use only. All self-contained units were tested at the factory to assure proper operation. The unit should not be installed directly next to high heat generating equipment (ranges, griddles, etc.). Be sure the location chosen has a counter strong enough to support the total weight of the cabinet and contents. A fully loaded model may weigh as much as 2000 pounds! Reinforce the counter as necessary to provide for maximum loading.

These units are installed by "dropping" them into the counter from above. The counter cutout sizes are as follows:

48" wide units — 18.62" x 23.62" (47.3 cm x 60.0 cm)

72" wide units — 18.62" x 32.62" (47.3 cm x 82.9 cm)

Self-contained F5 Series units require airflow to the compressor. Two louvers are provided with each unit and should be installed as illustrated on page 9.

Unit is designed to maintain 36°F (2°C) to 40°F (4°C) interior cabinet temperature at 65% or lower ambient relative humidity.

Plumbing

Self-contained models are standard with a condensate evaporator. If, for some reason, a unit does not have a

condensate evaporator, or the evaporator fails, the unit's drain must have an outlet to an appropriate drainage area or container.



Moisture collecting from improper drainage can create a slippery surface on the floor and a hazard to employees. It is the owner's and operator's responsibility to provide a container or outlet for drainage.

Electrical connection

Refer to the amperage data on pages 3 & 4, the serial tag, your local code or the National Electrical Code to be sure the unit is connected to the proper power source. A protected circuit of the correct voltage and amperage must be run for connection of the line cord, or permanent connection to the unit.

Self-contained units have an **ON/OFF** switch in the junction box. Simply turn the switch to **ON** to begin operation.



The power switch should be turned to OFF and the unit disconnected from the power source whenever performing service or maintenance functions.



OPERATION

After turning the ON/OFF switch to ON the unit's compressor will begin operating. Delfield display cases are designed to maintain an operational temperature of 36°F to 40°F (2°C to 4°C) in both the display (F5 and F15 Series) and storage areas (F15 Series only).

Continuous opening and closing of the doors will hamper the unit's ability to maintain operational temperatures.

If an excessively dirty condenser is the cause of the refrigeration system high pressure shut down, see "Cleaning the condenser" on page 7. Make sure the condenser is thoroughly clean before resetting the lock-out device.

PRESSURE CONTROL SETTING

Low pressure cut in at 20 psi.

Low pressure cut out at 5 psi.

Differential setting of 15 psi.

High pressure cutout at 450 psi.

INSTALLATION: REMOTE F5 SERIES

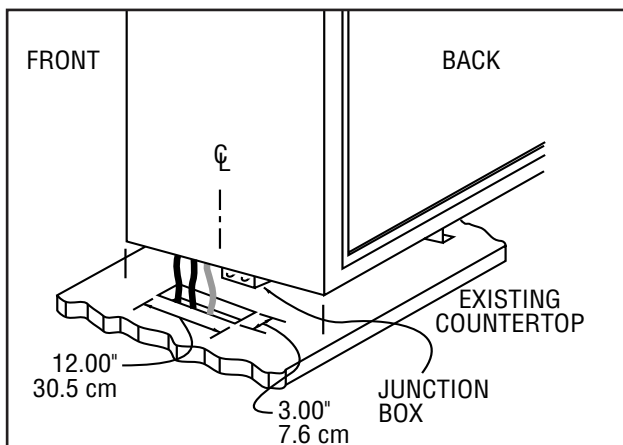

Provide a 3" x 12" (7.6 cm x 30.5 cm) slotted cutout to allow tubing, drain and electrical lines to pass through countertop under the side of the display cabinet for hook-up to remote condensing units. See diagrams for details.

MAINTENANCE

Stainless Steel Care and Cleaning

To prevent discoloration of rust on stainless steel several important steps need to be taken. First, we need to understand the properties of stainless steel. Stainless steel contains 70-80% iron which will rust. It also contains 12-30% chromium which forms an invisible passive film over the steels surface which acts as a shield against corrosion. As long as the protective layer is intact, the metal is still stainless. If the film is broken or contaminated, outside elements can begin to breakdown the steel and begin to form rust or discoloration.

Proper cleaning of stainless steel requires soft cloths or plastic scouring pads.

NEVER USE STEEL PADS, WIRE BRUSHES OR SCRAPERS!

Cleaning solutions need to be alkaline based or non-chloride cleaners. Any cleaner containing chlorides will damage the protective film of the stainless steel. Chlorides are also commonly found in hard water, salts, and household and industrial cleaners. If

cleaners containing chlorides are used be sure to rinse repeatedly and dry thoroughly upon completion.

Routine cleaning of stainless steel can be done with soap and water. Extreme stains or grease should be cleaned with a non-abrasive cleaner and plastic scrub pad. It is always good to rub with the grain of the steel. There are also stainless steel cleaners available which can restore and preserve the finish of the steels protective layer.

Early signs of stainless steel breakdown can consist of small pits and cracks. If this has begun, clean thoroughly and start to apply stainless steel cleaners in attempt to restore the passivity of the steel.

Never use an acid based cleaning solution! Many food products have an acidic content which can deteriorate the finish. Be sure to clean the stainless steel surfaces of ALL food products. Common items include, tomatoes, peppers and other vegetables.

MAINTENANCE



The power must be turned off and disconnected whenever performing maintenance or repair functions.

Cleaning the Condenser Coil

The condenser coil requires regular cleaning, recommended is every 90 days. In some instances though you may find that there is a large amount of debris and dust or grease accumulated prior to the 90 day time frame. In these cases the condenser coil should be cleaned every 30 days.

If the build up on the coil consists of only light dust and debris the condenser coil can be cleaned with a simple brush, heavier dust build up may require a vacuum or even compressed air to blow through the condenser coil.

If heavy grease is present there are de-greasing agents available for refrigeration use and specifically for the condenser coils. The condenser coil may require a spray with the de-greasing agent and then blown through with compressed air.

Failure to maintain a clean condenser coil can initially cause high temperatures and excessive run times, continuous operation with dirty or clogged condenser coils can result in compressor failures. Neglecting the condenser coil cleaning procedures will void any warranties associated with the compressor or cost to replace the compressor.



Never use a high pressure water wash for this cleaning procedure as water can damage the electrical components located near or at the condenser coil.



In order to maintain proper refrigeration performance, the condenser fins must be cleaned of dust, dirt and grease regularly. It is recommended that this be done at least every three months. If conditions are such that the condenser is totally blocked in three months, the frequency of cleaning should be increased. Clean the condenser with a vacuum cleaner or stiff brush. If extremely dirty, a commercially available condenser cleaner may be required.

Gasket Maintenance

Gaskets require regular cleaning to prevent mold and mildew build up and also to keep the elasticity of the gasket. Gasket cleaning can be done with the use of warm soapy water. Avoid full strength cleaning products on gaskets as this can cause them to become brittle and prevent proper seals. Also, never use sharp tools or knives to scrape or clean the gasket which could possibly tear the gasket and rip the bellows.

F15 Base Only

Gaskets can easily be replaced and do not require the use of tools or authorized service persons. The gaskets are "Dart" style and can be pulled out of the groove in the door and new gaskets can be "pressed" back into place.

Doors/Hinges

Over time and with heavy use, door hinges may become loose. If it is noticed that the door is beginning to sag, it may become necessary to tighten the screws that mount the hinge brackets to the frame of the unit. If the doors are loose or sagging this can cause the hinge to pull out of the frame which may damage both the doors and the door hinges. In some cases this can require qualified service agents or maintenance personnel.

Drain Maintenance

Each unit has a drain located inside the unit which removes the condensation from the evaporator coil and evaporates it at an external condensate evaporator pan. Each drain can become loose or disconnected from moving or bumping the drain. If you notice excessive water accumulation on the inside of the unit be sure the drain tube is connected from the evaporator housing to the condensate evaporator drain pan. If water is collected underneath the unit you may want to check the condensate evaporator drain tube to be sure it is still located inside the drain pan. The leveling of the unit is important as the units are designed to drain properly when on a level surface, if your floor is not level this can also cause drain problems. Be sure all drain lines are free of obstructions, typically food product is found blocking drain lines causing water to back up and overflow the drain pans.

Sliding Door Assembly Maintenance

All Delfield F5 Series and F15 Series display cases feature a Pike® sliding door assembly. A typical Pike sliding door assembly is shown in the illustration at right. See page 11 for parts list.

Frequent, regular cleaning with a mild soap and water solution will keep the tracks free of foreign matter and will insure many years of service.

The glass may be cleaned with one of the many glass cleaners currently available.

If it becomes necessary to replace a Pike sliding door assembly or a glass panel, have your unit's model and serial numbers available when you call Delfield's Service and Parts Department. Indicate that your unit has the Pike sliding door assembly when you call.

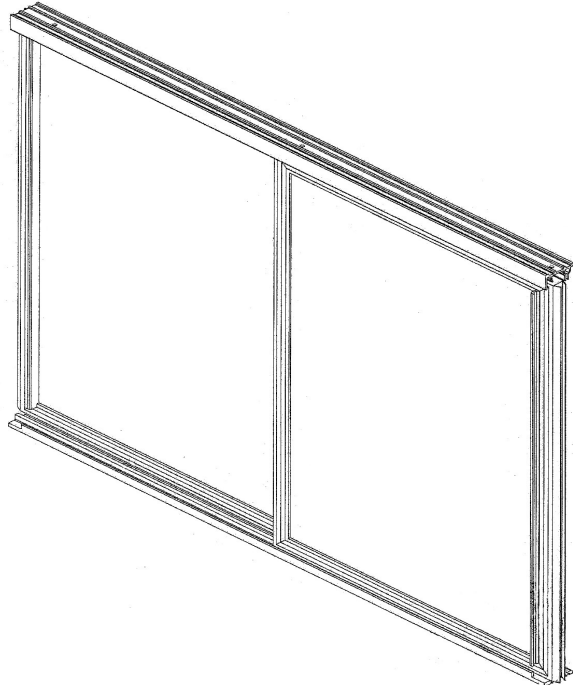

CONDENSER AIR FLOW: 48" & 72" WIDE UNITS

Unit is designed to be operated with supplied louvered panels for proper air flow. Failure to provide the proper air flow will void the warranty.

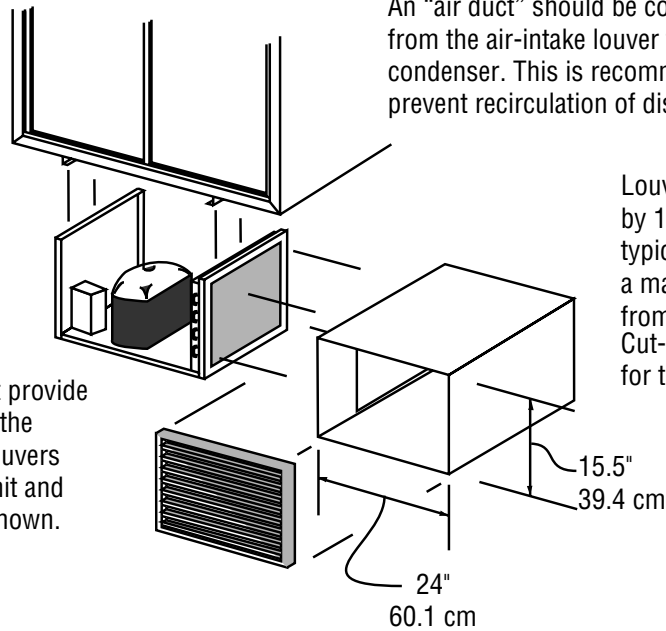

Proper installation must provide for air flow to and from the condensing unit. Two louvers are provided with the unit and should be installed as shown.

Louver cut-outs are 24" by 15.5" (60.1 cm by 39.4 cm) typical. Cut-outs are to begin a maximum of 4.00" (10.2 cm) from the counter-top. Cut-out dimensions are the same for the discharge louver.

Discharge air louver may be located further from fresh air louver, or on the opposite side of counter.

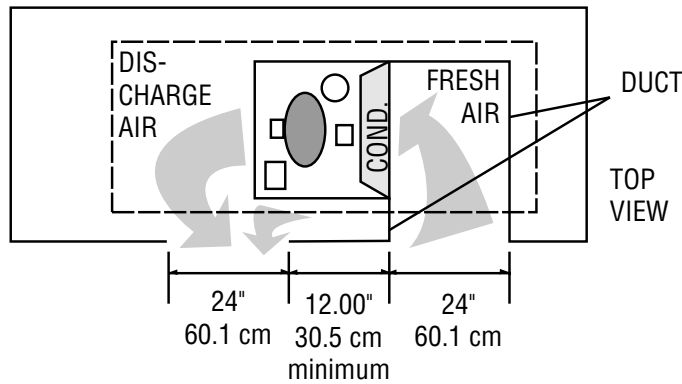

INSTALLATION: REMOTE F5 SERIES

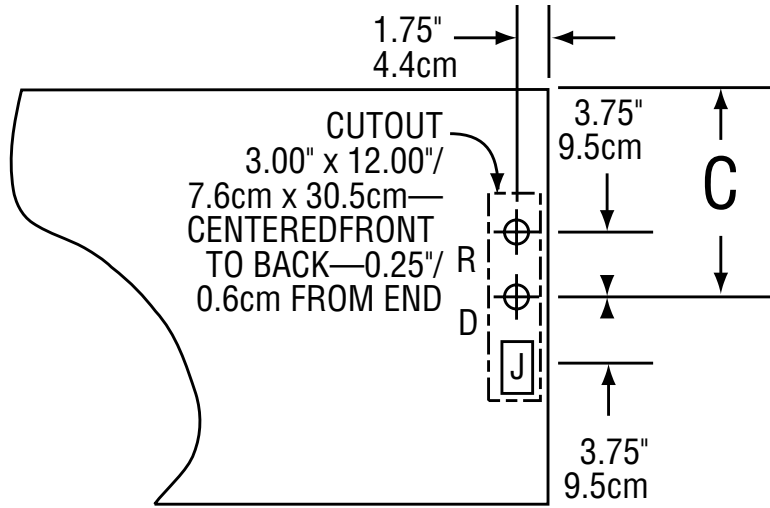

J=JUNCTION BOX
 R=REFRIGERATION
 LINES, .25" LIQUID,
 .37" SUCTION
 D=.50" I.D. DRAIN

FRONT OF UNIT

Typical Mechanical Access (Plan View)
 All F5 Models

INSTALLATION: REMOTE F15 SERIES

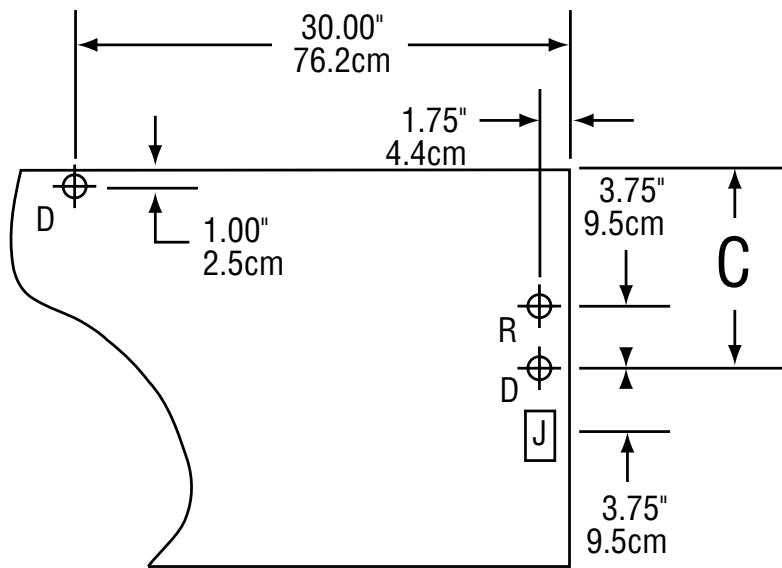

J=JUNCTION BOX
 R=REFRIGERATION
 LINES, .25" LIQUID,
 .37" SUCTION
 D=.50" I.D. DRAIN

FRONT OF UNIT

Typical Mechanical Access (Plan View)
 All F15 Models

PIKE DOOR COMPONENTS

48" UNITS

1. Bearing, roller, single	323-4636
2. Gasket, bumper, 31 13/16"	323-4808
3. Gasket, wiper strip, 30 3/8"	323-4809
4. Spring, 17" gold	323-4810
5. Track, bottom, 43 7/16"	323-4803
6. Track top, 44 7/16"	323-4800

72" UNITS

1. Bearing, roller, double.....	323-4637
2. Gasket, bumper, 31 13/16"	323-4808
3. Gasket, wiper strip, 30 3/8"	323-4809
4. Spring, 30" gold	323-3946
5. Track, bottom, 67 7/16"	323-4805
6. Track top, 68 7/16"	323-4802

Note: Pass-through units have two sets of sliding display doors, see-through and mirror-back units have one set.

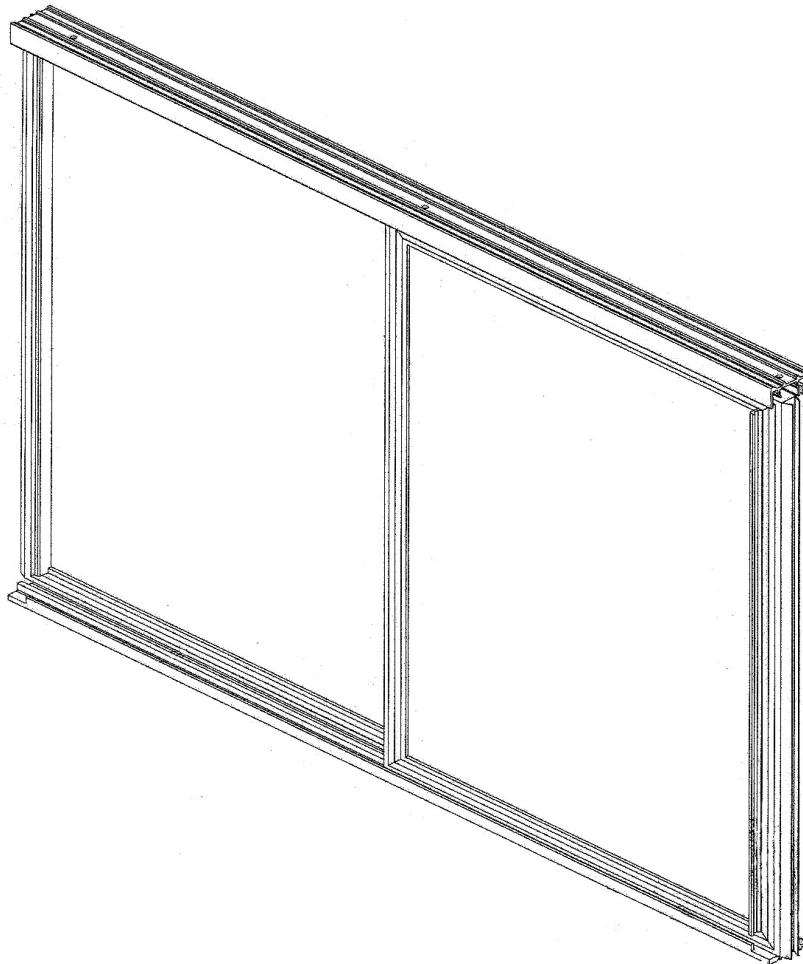

CONDENSING UNIT ASSEMBLY

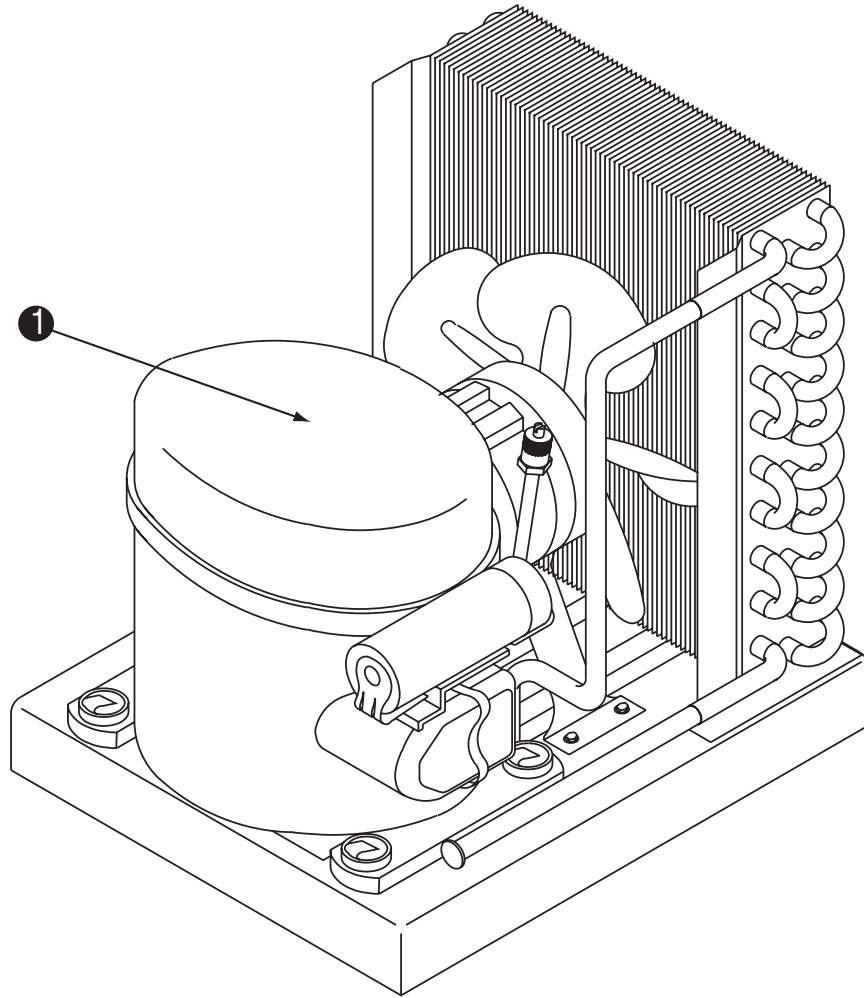

F5 48" Units 1/2 H.P.

KEY	DELFIELD PART#	DESCRIPTION
	3526731	1/2 H.P. med. condensing unit 404A
1	3526752	welded compressor
Refrigerant charges — 1/2 H.P. medium 404A — 32 oz.		

72" Units 3/4 H.P.

KEY	DELFIELD PART#	DESCRIPTION
	3526732	3/4 H.P. med. condensing unit 404A
1	3526753	welded compressor
Refrigerant charges — 3/4 H.P. medium 404A — 48 oz.		

For any condensing parts, please contact your local condensing unit wholesaler.

FLUORESCENT LIGHT FIXTURE

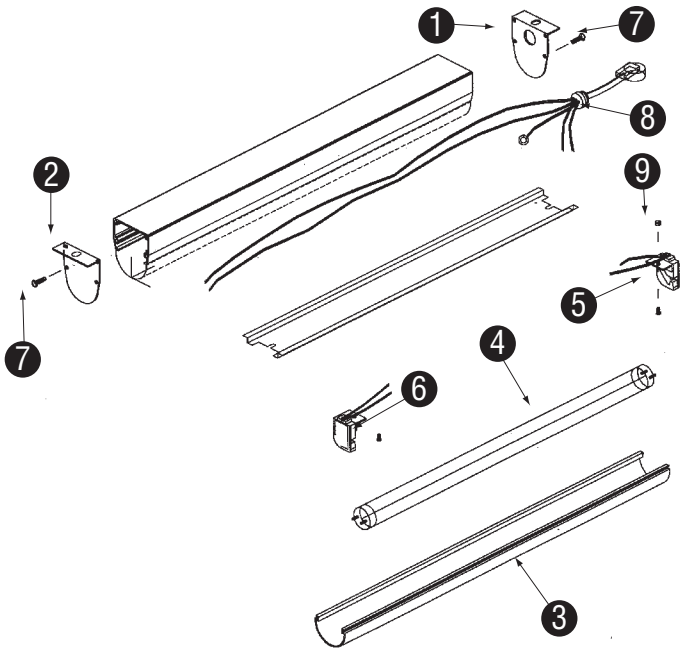

KEY	QTY	DELFIELD PART#	PRO-E PART #	DESCRIPTION
		XMK00132	000-406-0037	complete assembly, 36"
		XMK00133	000-406-0038	complete assembly, 48"
1	1	SMK00571	221-146-0032	cap, end, top mntg, pigtail, -rem.
2	1	SMK00572	221-146-0033	cap, end, top mntg, blank, -rem.
3	1	1701046		diffuser, fluor. light, 36"
	1	1701047		lamp, fluorescent, 48"
4	1	2193907		lamp, fluorescent, 36"
	1	2193908		lamp, fluorescent, 48"
5	1	2193939		lamp holder, left
6	1	2193940		lamp holder, right
7	8	9321266		screw, #8-32 x .50
8	1	2183613		pigtail, male, 3.5", rem. ballast
9	1	9321010		nut, hex, starlock, s/s, #6-32

* See page 15 for ballast information.

Non-numbered items are not sold separately. They are only available with a complete assembly.

DOOR ASSEMBLY: SERVIEW BASES

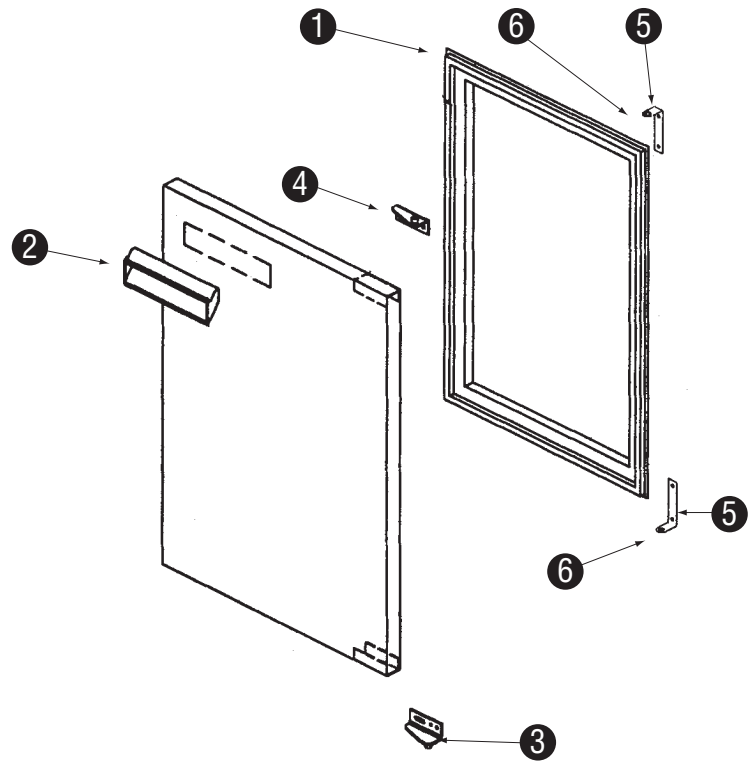

KEY	QUANTITY	DELFIELD PART#	DESCRIPTION
		XMK00001	complete door assy., 19", 18.75" x 25.72"
		XMK00002	complete door assy., 24", 23.75" x 25.72"
		XMK00003	complete door assy., 27", 26.75" x 25.72"
		XMK00004	complete door assy., 32", 31.75" x 25.72"
1	1	1701183	gasket, door, 19"
	1	1701184	gasket, door, 24"
	1	1701185	gasket, door, 27"
	1	1701186	gasket, door, 32"
2	NOT FIELD REPLACABLE		handle, snap-in, 7"
3	1	3234072	hinge, door, top/LH, bottom/RH
4	1	3234073	hinge, door, top/RH, bottom/LH
5	2	3234391	hinge, cabinet, L-shaped
6	2	9321107	bushing, nylon, hinge pin

Indicate whether door has left or right hinging when ordering.



Coil Assembly, Mullion, With Solenoid & Thermostat

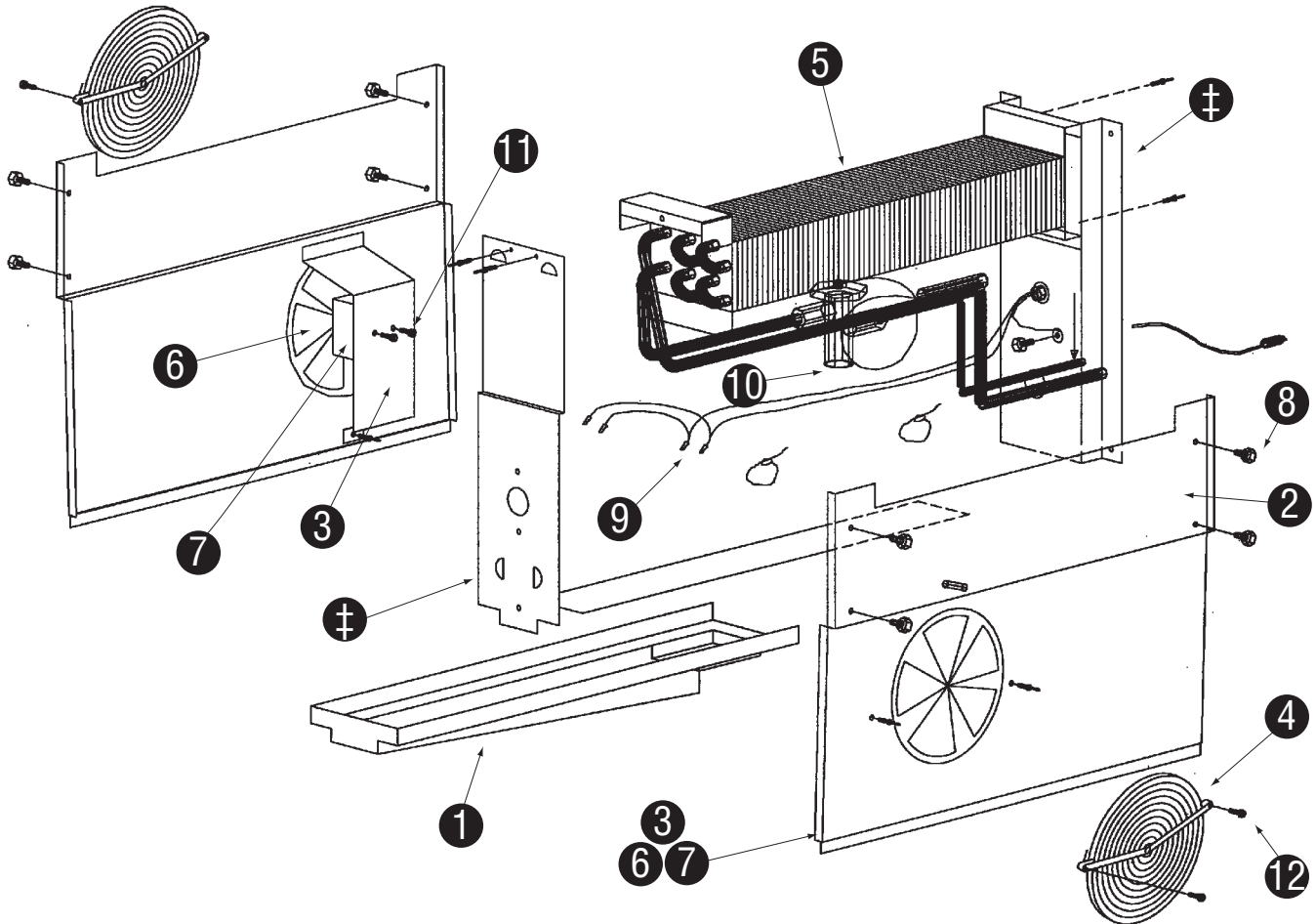

KEY	QUANTITY	DELFIELD PART#	DESCRIPTION
1	1	XMK00109 PMK00036	complete coil assembly pan, drip, evap. coil, refg.
‡	1	AMK00012	back coil
2	2	AMK00011	side, coil, w/fan
3	2	SMK00285	bracket, mounting, fan, evap, coil
4	2	3516173	guard, fan, 6.38" dia., Lexan
5	1	3516095	coil, evap.
‡	1	AMK00013	front, coil, w/t-stat
6	2	3516172	blade, fan 5.56, CCW, Lexan
7	2	2162691	motor, fan, 115V, 50/60, uppc0/bay
8	18	9321353	screw, #10 x 0.50,
9	1	2183312	harness, coil, w/t-stat-solenoid
10	1	3516273	valve, expansion, 1/4, hi, R-4040A
11	4	9321247	screw, machine, #10-32x37 long
12	4	9321068	screw, #10 x .87"
13	1	AMK00013	side, coil w/fan & thermostat
14	1	2194536	thermostat, in-39.5D/out-22.5D
15	1	3516103	coil, solenoid, 120v, spade, term.

NOTE: This Coil Requires:
 (1) Solenoid valve 15
 (1) Wiring Harness 9
 (1) Thermostat 14

NOTE: Non-numbered items not sold separately — available only with complete assembly.

Replacement Parts List — not shown on exploded views

DESCRIPTION	DELFIELD PART#
Supplied on all Servievs	
Leg, 6" with mount plate (4 used on 48" — 6 used on 72") . . .	3234645
Thermometer, hanging, 4" (one each in base & display)	3516135
Supplied on all Self-Contained Serview's — F15 Series	
Cord/plug assy, 16/3, NEMA 5-15P	21833470
Control, pressure, low	2193927
Dryer, filter, 1/4" ODF	3516101
Louver, 18", 17.94 x 26.34	SMK00041
Misc. Parts — Display Sections — F5 & F15 Series	
Ballast, rapid start 36" lamp	2193903
Blade, fan, Lexan, clear	3516172
Bracket, fan motor, blower coil	AMK00005
Coil, evaporator, 48"	3516090
Coil, evaporator, 72"	3516091
Coil, solenoid, 120V	3516074
Harness, elec., power to ballasts	2184063
Motor, fan, 115V 50/60	2162691
Pan, drip, evap coil, 42"	PMK00009
Pan, drip, evap coil, 72"	PMK00011
Pigtail, male, 9" rem. ballast (M only)	2183595
Switch, rocker, 20A/125V, 15A/250V	2190154
Thermometer, hanging, 4"	3516135
Thermostat, in-39.5D/out-22.5D	2194536
Valve, expansion, 1/2 ton, R404A	3516084

DESCRIPTION	DELFIELD PART#
Mirror Glass	
Mirror, glass, top, 48"	3455417
Mirror, glass, top, 72"	3455418
Shelving & Misc. Parts — Serview Bases	
Shelf support, plastic, plug 1"	3234290
Shelf, wire, 19", 14.38 x 25.25	3977984
Shelf, wire, 27", 22.56 x 25.25	3978014
Shelf, wire, 24", 19.38 x 25.25	3977998
Shelf, wire, 32", 27.38 x 25.25	3977983
Stud, dog-point, 1/4 x 1.50	9321132
Shelving for Mirror Back Display Cases	
Shelf, wire, 24" x 48" (M)	3977993
Shelf, wire, 24" x 72" (M)	3978061
Shelf, wire, 30" x 48" (M)	3978025
Shelf, wire, 30" x 72" (M)	3978062
Shelving for See Thru & Pass Thru Display Cases	
Shelf, wire, 24" x 48" (S&P)	3978026
Shelf, wire, 24" x 72" (S&P)	3978063
Shelf, wire, 30" x 48" (S&P)	3978027
Shelf, wire, 30" x 72" (S&P)	3978064
(M) = Mirror Back • (S&P) = See Thru & Pass Thru	



Wiring Diagram: Self-Contained F5 & F15 Series

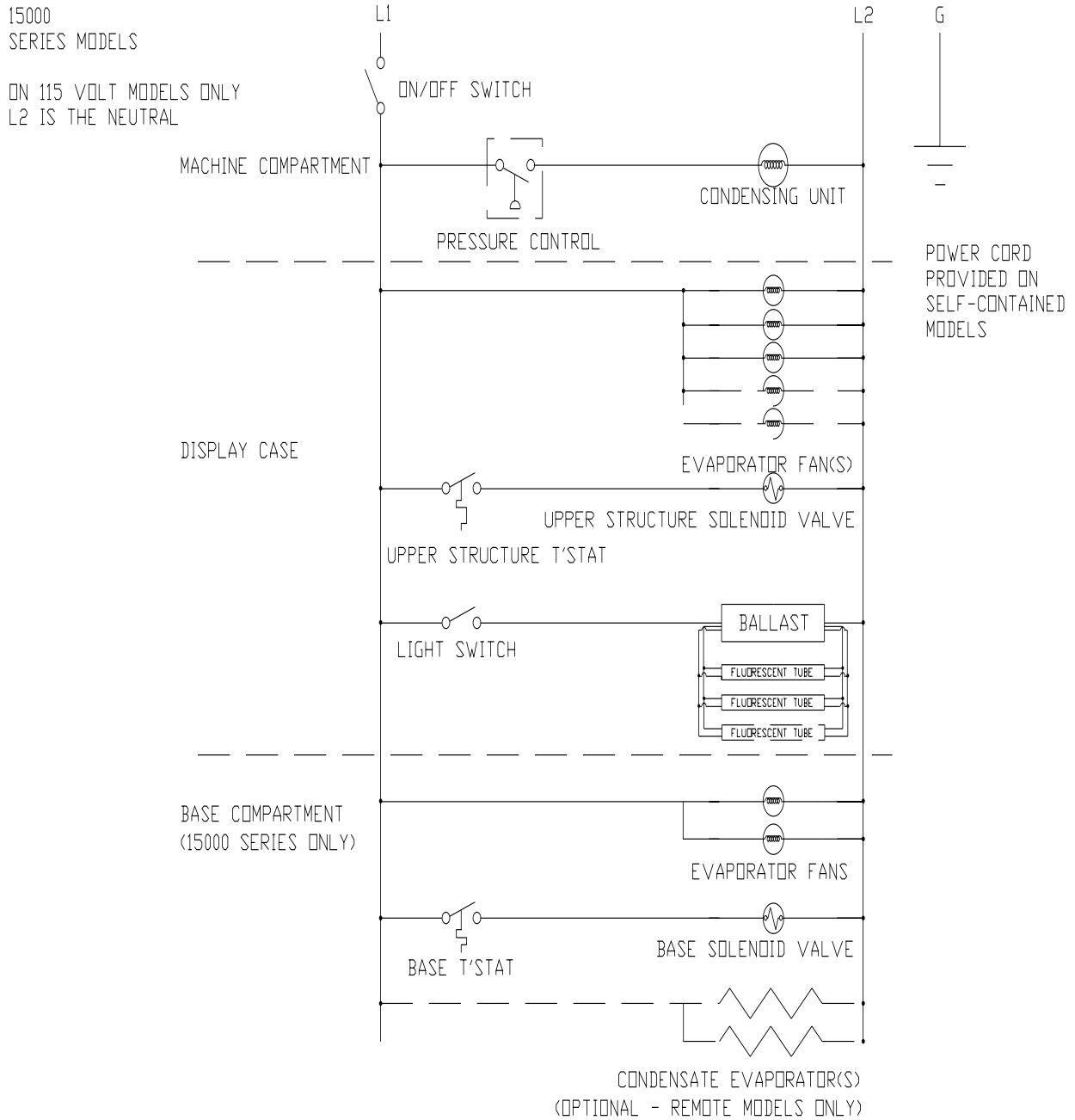

STANDARD LABOR GUIDELINES TO REPAIR OR REPLACE PARTS ON DELFIELD EQUIPMENT

Advice and recommendations given by Delfield Service Technicians do not constitute or guarantee any special coverage.

- A maximum of 1-hour is allowed to diagnose a defective component.
- A maximum of 1-hour is allowed for retrieval of parts not in stock.
- A maximum travel distance of 100 miles round trip and 2-hours will be reimbursed.
- Overtime, installation/start-up, normal control adjustments, general maintenance, glass breakage, freight damage, and/or correcting and end-user installation error will not be reimbursed under warranty unless pre-approved with a Service Work Authorization from Delfield. You must submit the number with the service claim.

LABOR OF 1-HOUR IS ALLOWED TO REPLACE:

- | | |
|---|---|
| <ul style="list-style-type: none"> • Thermostat • Infinite Switch • Door Jamb Switch • Solenoid Coil • Hi-limit/Thermal Protector Switch • Fan Delay/Defrost Termination Switch • Compressor Start Components and Overload Protector • Defrost Timer • Thermometer • Gear Box | <ul style="list-style-type: none"> • Contactor/Relay • Transformer • Evaporator/Condenser Fan Motor and Blade • Circulating Fan Motor and Blade • Microprocessor Control • Water Level Sensor/Probe • Door Hinges, Locks, and Gaskets • Condensate Element • Springs/Lowerator |
|---|---|

LABOR OF 2 HOURS TO REPLACE:

- | | |
|--|--|
| <ul style="list-style-type: none"> • Drawer Tracks/Cartridges • Pressure Control • Solenoid Valve | <ul style="list-style-type: none"> • Defrost Element • Heating Element • Locate/Repair Leak |
|--|--|

LABOR OF 3 HOURS TO REPLACE:

- | | |
|---|--|
| <ul style="list-style-type: none"> • EPR or CPR Valve • Expansion Valve | <ul style="list-style-type: none"> • Condenser or Evaporator Coil |
|---|--|

LABOR OF 4 HOURS TO REPLACE

- Compressor

This includes recovery of refrigerant and leak check.

\$35.00 maximum reimbursement for refrigerant recovery (includes recovery machine, pump, torch, oil, flux, minor fittings, solder, brazing rod, nitrogen, or similar fees.)

REFRIGERANTS

- R22 A maximum of \$4.00/lb. or 25¢/oz. will be reimbursed.
- R134A A maximum of \$5.00/lb. or 31¢/oz. will be reimbursed.
- R404A A maximum of \$12.00/lb. or 75¢/oz. will be reimbursed.



STANDARD ONE YEAR WARRANTY (ONE YEAR SERVICE AND LABOR)

The Delfield Company ("Delfield") warrants to the Original Purchaser of the Delfield product (herein called the "Unit") that such Unit, and all parts thereof, will be free from defects in material and workmanship under normal use and service for a period of one (1) year from the date of shipment of the Unit to the Original Purchaser or, if the Original Purchaser returns the warranty card completely filled out including the date of installation within thirty (30) days of receipt of the Unit, one (1) year from the date of installation. During this one year warranty period, Delfield will repair or replace any defective part or portion thereof returned to Delfield by the Original Purchaser which Delfield determines was defective due to faulty material or workmanship. The Original purchaser will pay all labor, crating, freight and related costs incurred in the removal of the Unit of defective component and shipment to Delfield, except that during a period of either ninety (90) days from the date of shipment of the Unit to the Original Purchaser or, if the Original Purchaser returns the warranty card completely filled out including the date of installation within thirty (30) days of receipt of the Unit, ninety (90) days from the date of installation Delfield will pay all related labor costs. Delfield will pay the return costs if the Unit or part thereof was defective.

The term "Original Purchaser" as used herein means that person, firm, association, or corporation for whom the Unit was originally installed.

This warranty does not apply to any Unit or part thereof that has been subjected to misuse, neglect, alteration, or accident, such as accidental damage to the exterior finish, operated contrary to the recommendations specified by Delfield; or repaired or altered by anyone other than Delfield in any way so as to, in Delfield's sole judgement, affect its quality or efficiency. This warranty does not apply to any Unit that has been moved from the location where it was originally installed. This warranty also does not cover the refrigerator drier or the light bulbs used in the Unit. The warranty is subject to the user's normal maintenance and care responsibility as set forth in the Service and Installation Manual, such as cleaning the condenser coil, and is in lieu of all other obligations of Delfield. Delfield neither assumes, nor authorizes any other person to assume for Delfield, any other liability in connection with Delfield's products.

Removal or defacement of the original Serial Number or Model Number from any Unit shall be deemed to release Delfield from all obligations hereunder or any other obligations, express or implied.

Parts furnished by suppliers to Delfield are guaranteed by Delfield only to the extent of the original manufacturer's express warranty to Delfield. Failure of the Original Purchaser to receive such manufacturer's express warranty to Delfield. Failure of the Original Purchaser to receive such manufacturer's warranty shall in no way create any warranty, expressed or implied, or any other obligation or liability on Delfield's part in respect thereof.

IF THE CUSTOMER IS USING A PART THAT RESULTS IN A VOIDED WARRANTY AND A DELFIELD AUTHORIZED REPRESENTATIVE TRAVELS TO THE INSTALLATION ADDRESS TO PERFORM WARRANTY SERVICE, THE SERVICE REPRESENTATIVE WILL ADVISE CUSTOMER THE WARRANTY IS VOID. SUCH SERVICE CALLS WILL BE BILLED TO CUSTOMER AT THE AUTHORIZED SERVICE CENTER'S THEN APPLICABLE TIME AND MATERIALS RATES. CONSIDER: CUSTOMER MAY INITIATE A SERVICE AGREEMENT WITHOUT PARTS COVERAGE.

If shipment of a replacement part is requested prior to the arrival in the Delfield factory of the part claimed to be defective, the Original Purchaser must accept delivery of the replacement part of a C.O.D. basis, with credit being issued after the part has been received and inspected at Delfield's plant and determined by Delfield to be within this warranty.

Under no condition does this warranty give the Original Purchaser the right to replace the defective Unit with a complete Unit of the same manufacturer or of another make. Unless authorized by Delfield in writing, this warranty does not permit the replacement of any part, including the motor-compressor, to be made with the part of another make or manufacturer.

No claims can be made under this warranty for spoilage of any products for any reason, including system failure.

The installation contractor shall be responsible for building access, entrance and field conditions to insure sufficient clearance to allow any hood(s), vent(s), or Unit(s) if necessary, to be brought into the building. Delfield will not be responsible for structural changes or damages incurred during installation of the Unit or any exhaust system.

Delfield shall not be liable in any manner for any default or delay in performance hereunder caused by or resulting from any contingency beyond Delfield's control, including, but not limited to, war, governmental restrictions or restraints, strike, lockouts, injunctions, fire, flood, acts of nature, short or reduced supply of raw materials, or discontinuance of the parts by the original part manufacturer.

Except as provided in any Additional Four Year Protection Plan, if applicable, and the Service Labor Contract, if applicable, the foregoing is exclusive and in lieu of all other warranties, whether written or oral, express or implied. This warranty supersedes and excludes any prior oral or written representations or warranties. Delfield expressly disclaims any implied warranties of merchantability, fitness for a particular purpose of compliance with any law, treaty, rule or regulation relating to the discharge of substances into the environment. The sole and exclusive remedies of any person relating to the Unit, and the full liability of Delfield for any breach of this warranty, will be as provided in this warranty.

Other than this Delfield Standard One Year Limited Warranty, any applicable Delfield Additional Four Year Protection Plan or applicable Delfield Service Labor Contract, the Original Purchaser agrees and acknowledges that no other warranties are offered or provided in connection with or for the unit or any other part thereof.

In no event will Delfield be liable for special, incidental or consequential damages, or for damages in the nature of penalties.

IF DURING THE WARRANTY PERIOD, CUSTOMER USES A PART FOR THIS DELFIELD EQUIPMENT OTHER THAN AN UNMODIFIED NEW OR RECYCLED PART PURCHASED DIRECTLY FROM DELFIELD OR ANY OF ITS AUTHORIZED SERVICE CENTERS AND/OR THE PART BEING USED IS MODIFIED FROM ITS ORIGINAL CONFIGURATION, THIS WARRANTY WILL BE VOID. FURTHER, DELFIELD AND ITS AFFILIATES WILL NOT BE LIABLE FOR ANY CLAIMS DAMAGES OR EXPENSES INCURRED BY THE CUSTOMER WHICH ARISE DIRECTLY OR INDIRECTLY, IN WHOLE OR IN PART, DUE TO THE INSTALLATION OF ANY MODIFIED PART AND/OR PART RECEIVED FROM AN UNAUTHORIZED SERVICE CENTER. If the warranty becomes void, Customer may purchase from Delfield, if available, a Service Agreement or service at the then current time and materials rate.

For more information on Delfield warranty's log on and check out the service section of our web site at www.delfield.com.

ADDITIONAL FOUR YEAR PROTECTION PLAN (FOR MOTOR-COMPRESSOR ONLY)

Delfield Model#	Serial #	Installation Date

In addition to the Standard One Year Warranty on the Motor-Compressor contained in the above listed Delfield product (the "Unit"), The Delfield Company ("Delfield") also agrees to repair, or exchange with similar or interchangeable parts in design and capacity at Delfield's option, the defective Motor-Compressor contained in the Unit (the "Motor-Compressor), or any part thereof, for the Original Purchaser only, at any time during the four (4) years following the initial one (1) year period commencing on the date of installation for the Original Purchaser. Failure of the Original Purchaser to register the registration card containing the Original Purchasers name, address, date of installation, model number and serial number of the Unit containing the Motor-Compressor within 30 days from the date of installation shall void this warranty. This additional warranty is only available if the Motor-Compressor is inoperative due to defects in material or factory workmanship, as determined by Delfield in its sole judgement and discretion. The Original Purchaser shall be responsible for returning the defective Motor-Compressor to Delfield prepaid, F.O.B. at the address shown on the back cover of this manual.

The term "Original Purchaser" as used herein means that person, firm, association, or corporation for whom the Unit was originally installed.

The term "Motor-Compressor" as used herein does not include unit base, air or water cooled condenser, receiver, electrical accessories such as relay, capacitors, refrigerant controls, or condenser fan/motor assembly. This warranty does not cover labor charges incidental to the replacement of parts. This warranty further does not include any equipment to which said condensing unit is connected, such as cooling coils, temperature controls or refrigerant metering devices. This warranty shall be void if the Motor-Compressor, in Delfield's sole judgement, has been subjected to misuse, neglect, alteration or accident, operated contrary to the recommendations specified by the Unit manufacturer, repaired or altered by anyone other than Delfield in any way so as, in Delfield's sole judgment, to affect its quality or efficiency or if the serial number has been altered, defaced or removed. This Warranty does not apply to a Motor-Compressor in any Unit that has been moved from the location where it was originally installed. The addition of methyl chloride to the condensing unit or refrigeration system shall void this warranty.

General Conditions

Delfield shall not be liable in any manner for any default or delay in performance hereunder caused by or resulting from any contingency beyond Delfield's control, including, but not limited to, war, governmental restrictions or restraints, strike, lockouts, injunctions, fire, flood, acts of nature, short or reduced supply of raw materials, or discontinuance of any part or the Motor-Compressor by the unit manufacturer.

Replacement of a defective Motor-Compressor is limited to one (1) Motor-Compressor by us during the four (4) year period. Delfield shall replace the Motor-Compressor at no charge.

This warranty does not give the Original Purchaser of the Motor-Compressor

the right to purchase a complete replacement Motor-Compressor of the same make or of another make. It further does not permit the replacement to be made with a Motor-Compressor of another kind unless authorized by Delfield. In the event Delfield authorizes the Original Purchaser to purchase a replacement Motor-Compressor locally, only the wholesale cost of the Motor-Compressor is refundable.

Expressly excluded from this warranty are damages resulting from spoilage of goods.

Except as provided in any applicable Standard One Year Limited Warranty or applicable Service Labor Contract, the foregoing is exclusive and in lieu of all other warranties, whether written or oral, express or implied. This Warranty supersedes and excludes any prior oral or written representations or warranties. Delfield expressly disclaims any implied warranties of merchantability, fitness for a particular purpose or compliance with any law, treaty, rule or regulation relating to the Motor-Compressor, and the full liability of Delfield for any breach of this warranty, will be as provided in this warranty.

Other than any applicable Delfield Standard One year Limited Warranty, this Delfield Additional Four Year Protection Plan and any applicable Delfield Service Labor Contract, the Original Purchaser agrees and acknowledges that no other warranties are offered or provided in connection with or for the Motor-Compressor or any part thereof.

In no event will Delfield be liable for special, incidental or consequential damages, or for damages in the nature of penalties.



AUTHORIZED PARTS DEPOT

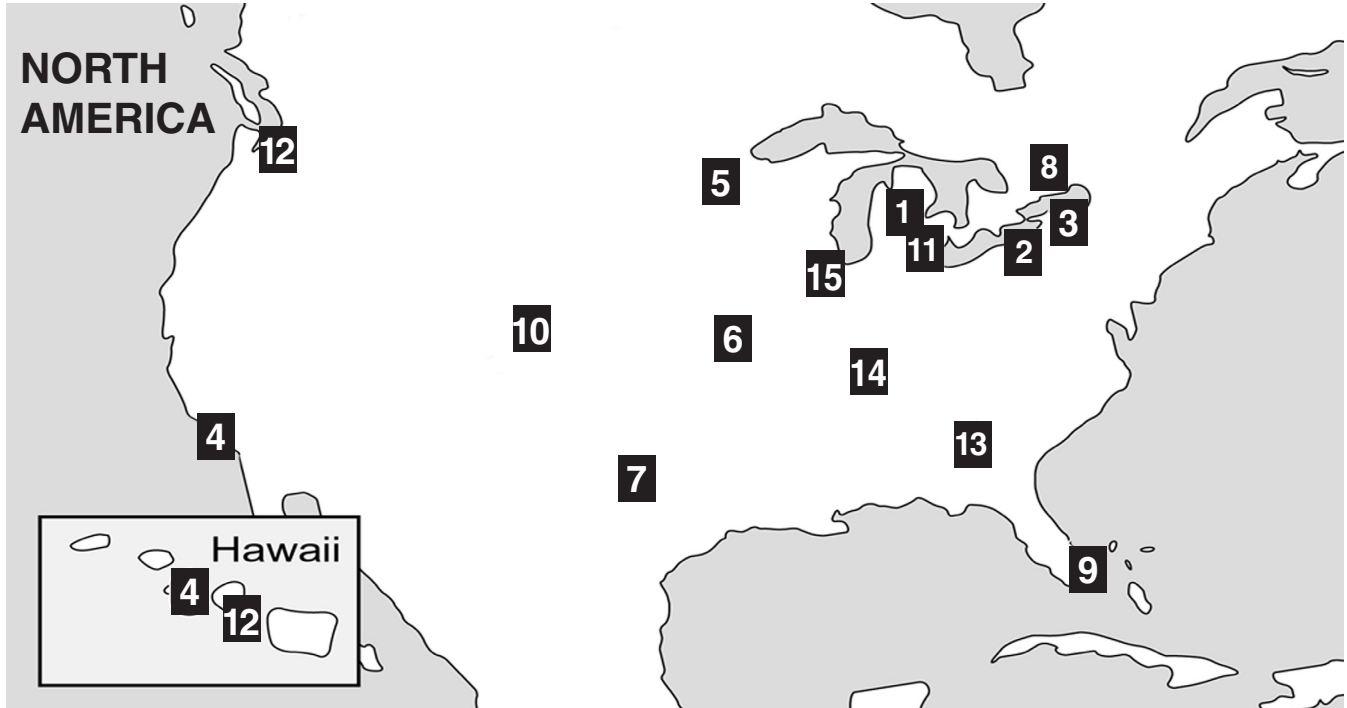

<p>1) The Delfield Company</p> <p>980 South Isabella Road Mt. Pleasant, MI 48858 800.733.8829 989.773.7981 989.773.3210 FAX custom parts direct from Delfield</p>	<p>2) A.I.S. Commercial Parts & Service</p> <p>1816 West 26th Street Erie, PA 16508-1149 800.332.3732 814.456.3732 814.452.4843 FAX serves: MD, NJ, OH, PA, VA, WV</p>	<p>3) Appliance Installation Service</p> <p>1336 Main Street Buffalo, NY 14209 800.722.1252 716.884.7425 716.884.0410 FAX serves: CT, DC, DE, MA, MD, ME, NH, NJ, NY, PA, RI, VA, VT, WV</p>	<p>4) Pacific Coast Parts</p> <p>15024 Staff Court Gardena, CA 90248 1.800.531.1111 1.800.782.5747 Email: orders@pacparts.com www.pacparts.com serves: AZ, CA, HI, NV, OR</p>
<p>5) Contract Ice</p> <p>14450 Ewing Ave S. #100 Burnsville, MN 55306 800.422.2823 952.894.4427 952.894.2164 FAX serves: IA, MN, MT, ND, SD, WI</p>	<p>6) E.M.C.O. Sales & Distributors</p> <p>3909 St. Timothy Lane St. Ann, MO 63074 800.972.7670 314.427.7477 314.427.8190 FAX serves: AR, IA, IL, KS, KY, MO, NE, OK, TX, NM, LA</p>	<p>7) Stove Parts Supply/GCS Service</p> <p>2120 Solona St. PO Box 14009 Fort Worth, TX 76117-0009 1.800.433.1804 toll free 1.800.272.7358 fax serves: AR, LA, NM, OK, TX</p>	<p>8) Garland Group</p> <p>1177 Kamato Road Mississauga, Ontario L4W1X4 800.361.7745 FAX serves: Canada</p>
<p>9) Global Parts and Supplies</p> <p>2920 N.W. 109th Avenue Miami, FL 33172 305.994.9994 305.994.9992 FAX International parts depot</p>	<p>10) Hawkins Commercial Appl. Serv.</p> <p>3000 S. Wyandot Englewood, CO 80110 (800) 624-2117 (303) 7618861 FAX serves: AZ, CO, KS, NE, NM, OK, UT, WY</p>	<p>11) MicroDine, Inc.</p> <p>44792 Helm Plymouth, MI 48170 888.828.4454 734.451.2043 734.451.3215 FAX serves: MI, IN, WI, OH</p>	<p>12) Performance Refrigeration Parts</p> <p>9923 S.W. 178th St. Vashon, WA 98070 888.872.2465 206-463-1772 206.463.4431 FAX serves: AK, HI, ID, MT, OR, WA</p>
<p>13) Southeastern Restaurant Services</p> <p>2200 Norcross Parkway, Suite 210 Atlanta, GA 30071 800.235.6516 770.446.6177 770.446.3157 FAX serves: FL, GA, MS, NC, SC, VA</p>	<p>14) T.M.A.</p> <p>2916 Sidco Drive Nashville, TN 37204 615.726.0351 800.737.0351 615.259.4100 FAX serves: TN, AL</p>	<p>15) Heritage Food Serv. Equip. Inc.</p> <p>5130 Executive Blvd. Fort Wayne, IN 46808 800.458.5593 800.800.4981 FAX serves: IL, IN, MI, OH, WI</p>	<p>Delfield has 15 conveniently located Parts Depots to ensure parts are handled promptly and accurately.</p> <p>Delfield reserves the right to update or make changes to this list without prior notice. Please call 1-800-733-8829 or check the web at www.delfield.com for a list of the current Parts Depots.</p>



980 S. Isabella Rd., Mt. Pleasant, MI 48804-0470, U.S.A. • (989) 773-7981 or (800) 733-8829 • Fax (989) 773-3210 • www.delfield.com
Delfield reserves the right to make changes in design or specifications without prior notice. ©2003 The Delfield Company. All rights reserved. Printed in the U.S.A.

DM5_15 1/04