



500 Series

Service and Installation Manual

Please read this manual completely before attempting to install or operate this equipment! **Notify carrier of damage!** Inspect all components immediately. See page 2.



 **CAUTION**

**IMPORTANT INFORMATION
READ BEFORE USE
PLEASE SAVE THESE INSTRUCTIONS!**

Effective May 2003

CONTENTS

RECEIVING & INSPECTING EQUIPMENT.....	2
SPECIFICATIONS	3
PRESSURE CONTROL SETTINGS.....	5
INSTALLATION.....	5, 6
OPERATION	5, 6
CARE & CLEANING.....	6
WIRING DIAGRAMS	
500-CR self-contained refrigerated units.....	7
500-OR open refrigerated units.....	7
500-CD dry storage units.....	8
500-CH curved heated units.....	8
EXPLODED VIEWS & PARTS LISTS	
537-CD	9
549-CD	9
561-CD	10
573-CD	10
537-CR, CRR	11
549-CR, CRR	11
561-CR, CRR	12
573-CR, CRR	12
549-CH	13
561-CH	13
573-CH	14
549-OR	14
FLUORESCENT LIGHT ASSEMBLY	15
DOOR ASSEMBLY.....	16
REFRIGERATION ASSEMBLES	17
FOOD WELL ASSEMBLY	18
REPLACEMENT PARTS LIST	19
STANDARD LABOR GUIDELINES.....	20
STANDARD WARRANTIES.....	21-22
AUTHORIZED PARTS DEPOTS.....	back cover

SERIAL NUMBER LOCATION

The **Serial number** on all 500 Series units is located on the rear of the unit, near the ON/OFF switch.

Always have the serial number of your unit available when calling for parts or service. A complete list of authorized Delfield parts depots is shown on the back cover of this manual.

©2003 The Delfield Company. All rights reserved. Reproduction without written permission is prohibited. "Delfield" is a registered trademark of The Delfield Company.

RECEIVING AND INSPECTING THE EQUIPMENT

Even though most equipment is shipped crated, care should be taken during unloading so the equipment is not damaged while being moved into the building.

1. Visually inspect the exterior of the package and skid or container. Any damage should be noted and reported to the delivering carrier immediately.
2. If damaged, open and inspect the contents with the carrier.
3. In the event that the exterior is not damaged, yet upon opening, there is concealed damage to the equipment notify the carrier. Notification should be made verbally as well as in written form.
4. Request an inspection by the shipping company of the damaged equipment. This should be done within 10 days from receipt of the equipment.
5. Check the lower portion of the unit to be sure adjustable feet are not bent.
6. Also open the compressor compartment housing and visually inspect the refrigeration package. Be sure lines are secure and base is still intact.
7. Freight carriers can supply the necessary damage forms upon request.
8. Retain all crating material until an inspection has been made or waived.

Uncrating the Equipment

First cut and remove the banding from around the crate. Remove the front of the crate material, use of some tools will be required. If the unit is on legs remove the top of the crate as well and lift the unit off the skid.

500 SERIES SPECIFICATIONS

MODEL NUMBER	DELFIELD PART #	VOLTS/HERTZ PHASE	AMPS (includes lights & fan)
Dry Storage Display Cases			
537-CD	078-5371	115/60/1	5.0
549-CD	078-5491	115/60/1	5.0
561-CD	078-5611	115/60/1	5.0
573-CD	078-5731	115/60/1	5.0

MODEL NUMBER	DELFIELD PART #	NUMBER OF 12 X 20 WELLS	VOLTS/HERTZ PHASE	AMPS
Heated Display Cases				
549-CH	078-5494	3	120, 208-240V/60/1	19.0/21.0
561-CH	078-5614	4	120, 208-240V/60/1	24.0/27.0
573-CH	078-5734	5	120, 208-240V/60/1	30.0/34.0

MODEL NUMBER	DELFIELD PART #	H.P.*	VOLTS/HERTZ PHASE	AMPS	EVAPORATOR CAPACITY BTU/°TD	CABINET LOAD BTU/HOUR
Remote Refrigerated Display Cases						
537-CRR	CONSULT FACTORY	1/2*	115/60/1	5.0	180	1730
549-CRR	078-5493	1/2*	115/60/1	5.0	190	2250
561-CRR	078-5613	3/4*	115/60/1	6.0	190	2770
573-CRR	078-5733	3/4*	115/60/1	6.0	290	3290

*Recommended horsepower

MODEL NUMBER	DELFIELD PART #	H.P.	VOLTS/HERTZ PHASE	AMPS	CABINET LOAD BTU/HOUR	SYSTEM CAPACITY BTU/HOUR	REFRIGERATION CHARGE 404A
Self-Contained Refrigerated Display Cases							
537-CR	078-5372	1/2	115/60/1	12.0	1730	3258	32 oz.
549-CR	078-5492	1/2	115/60/1	12.0	2250	3316	32 oz.
561-CR	078-5612	3/4	115/60/1	16.0	2770	4919	48 oz.
573-CR	078-5732	3/4	115/60/1	16.0	3290	5387	48 oz.

MODEL NUMBER	DELFIELD PART#	H.P.	VOLTS/HERTZ PHASE	AMPS	CABINET LOAD BTU/HOUR	SYSTEM CAPACITY BTU/HOUR	REFRIGERATION CHARGE 404A
Open Front Refrigerated Display Cases							
549-OR	078-5495	1/2	115/60/1	12.0	2030	3354	32 oz.



INSTALLATION: 500 CD, CR, CRR & OR

Location



To meet NSF standards, all units must be sealed to the floor.

Be sure the location chosen has a floor strong enough to support the total weight of the cabinet and contents. Contents fully loaded in this product line can weigh as much as 1500 lbs. Reinforce the floor as necessary to provide for maximum loading.

For the most efficient refrigeration, be sure to provide good air circulation inside and out. Do not pack the refrigerator so full that air cannot circulate. Be sure that the exterior of the unit has access to ample air. Avoid hot corners and locations near stoves and ovens.

Leveling

To level unit, simply lower the four adjustable rubber feet located under the unit to the floor and adjust until unit is level. A level cabinet will perform better because the drain will empty properly, the doors will line up with the frames correctly and the cabinet will not be subject to undue strain.

Plumbing

Self-contained models are standard with a condensate evaporator. If the evaporator fails, the unit's drain must have an outlet to an appropriate drainage area or container.



Moisture collecting from improper drainage can create a slippery surface on the floor and a hazard to employees. It is the owner's and operator's responsibility to provide a container or outlet for drainage.

Electrical connection

Refer to the amperage data on page 3, the serial tag, your local code or the National Electrical Code to be sure the unit is connected to the proper power source. A protected circuit of the correct voltage and amperage must be run for connection of the line cord, or permanent connection to the unit.

Self-contained units have an ON/OFF switch located on the operators side. Simply turn the switch to ON to begin operation.



The power switch should be turned to OFF and the unit disconnected from the power source whenever performing service or maintenance functions.

OPERATION: 500 CD, CR, CRR & OR

On self-contained models, after turning the ON/OFF switch to ON, the unit's compressor will begin operating. Delfield display cases are designed to maintain an operational temperature of 36°F to 40°F.

Do not load the storage area in a way that restricts the air flow. Overloading will result in the loss of temperature. Do not throw items into the storage area. The interior of the cabinet and the blower coil may be damaged by this type of neglect, which is not covered under your warranty.



These units use HFC-404A refrigerant, and have a lock-out high pressure limiting device. Under severe overloading conditions, in the event of a condenser fan failure or a plugged or blocked condenser, this device may shut down the refrigeration system. See page 17 for part number information if a replacement is required.

CONTROL SETTINGS: 500 CR & OR

Pressure Control

The temperature is controlled by an adjustable pressure control located in the machine compartment. An adjustable control has the word **COLDER** near the knob, with an arrow to indicate the adjustment direction. These controls are field adjustable and do not require a service agent. If you have any questions, feel free to contact the Delfield Service Department.

The refrigeration systems on self-contained CR & OR models were adjusted at the factory to maintain between 36°F and 40°F. No adjustment should be necessary. If adjustment does become needed however, the factory recommended settings are:

Low-pressure settings (CR models): 82 psi cut-in,
47 psi cut-out, 35 psi differential.

Low-pressure settings (OR models): 82 psi cut-in,
40 psi cut-out, 42 psi differential.

Operating pressures: High, 170 to 200 psi. Low, 30 to 37 psi.

In attempting to adjust the pressure control, you can do damage to your unit by accidentally adjusting the differential. Please make small incremental adjustments if a temperature adjustment is necessary, please contact the service department at Delfield (800) 733-8829 #1, or your local service agent. Delfield is not responsible for charges incurred while having the pressure control adjusted.

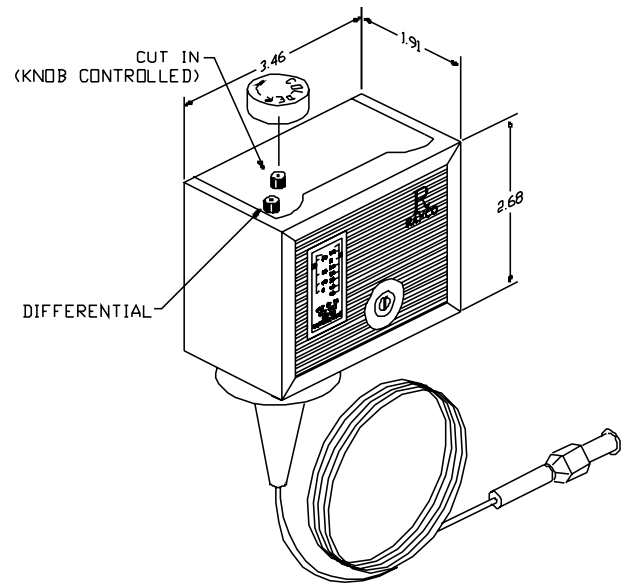

INSTALLATION: 500 CH



Installation should be done by personnel certified and licensed to install and maintain electrical appliances.

Location

Be sure the location chosen has a floor strong enough to support the total weight of the cabinet and contents. Contents fully loaded into this product line can weigh as much as 1500 lbs. Reinforce the floor as necessary to provide for maximum loading.

Leveling

A level cabinet looks better and will perform better because the drain pan will drain properly, the doors will line up with the frames properly, and the cabinet will not be subject to undue strain.

Electrical connection



Connections must be made in accordance with all applicable local codes and/or the National Electrical Code. Refer to the wiring diagrams on pages 6 and 7.

OPERATION: 500 CH

NOTE: Intended for DRY OPERATION ONLY.

Before the unit is used the first time for serving, turn the temperature knob to "10" and heat the well for 20 minutes. Do not be alarmed if smoke appears; this preheat should burn off any residue or dust on the heating element.



Hot surfaces can cause serious burns. Always wear some type of protective covering on your hands and arms when removing lids or pans from the unit.

Never place food directly into the well. Always use pans. Always place covers on pans when not serving to prevent food from drying out and to reduce your operating cost.

For most efficient operation, keep covered insets empty in each well during preheating and when the well is not in use.

Dry operation



- 1) Pre-heat the well on "HIGH" for approximately 15 minutes.
- 2) After pre-heating, set the control to your desired serving temperature.

Only 6" (15.2cm) deep insets should be used with a dry food well. When operated dry, the bottom of the food well will discolor. Refer to cleaning instructions to remove discoloration.

Temperature

Product in pans 140°F to 160°F

CLEANING: ALL MODELS

Clean the food wells daily. Wash with non-abrasive cleanser and non-abrasive pad. If necessary, a mild abrasive may be used. Do not use steel wool.

For all stainless steel parts, use mild, non-abrasive soap or detergent and warm water. This may be followed by an application of stainless steel cleaner or polish which will eliminate water spotting and fingerprints and will bring out the finish of the stainless steel.

Do not use a hose or pressure wash on these units. The water will damage the electrical components.



Cleaning the condenser (refrigerated units)

In order to maintain proper refrigeration, the condenser fins must be cleaned of dust, dirt and grease every three months. If condenser is totally blocked after three months increase cleaning frequency. Clean the condenser with a vacuum cleaner or stiff brush. If extremely dirty, use a commercially available condenser cleaner.

Cleaning the sliding door assembly

All Delfield 500 Series display cases feature a Pike sliding door assembly. Regular cleaning of door tracks with mild soap and water will keep them free of foreign matter insuring many years of use. The glass may be cleaned with a glass cleaner.

WIRING: 500 CD

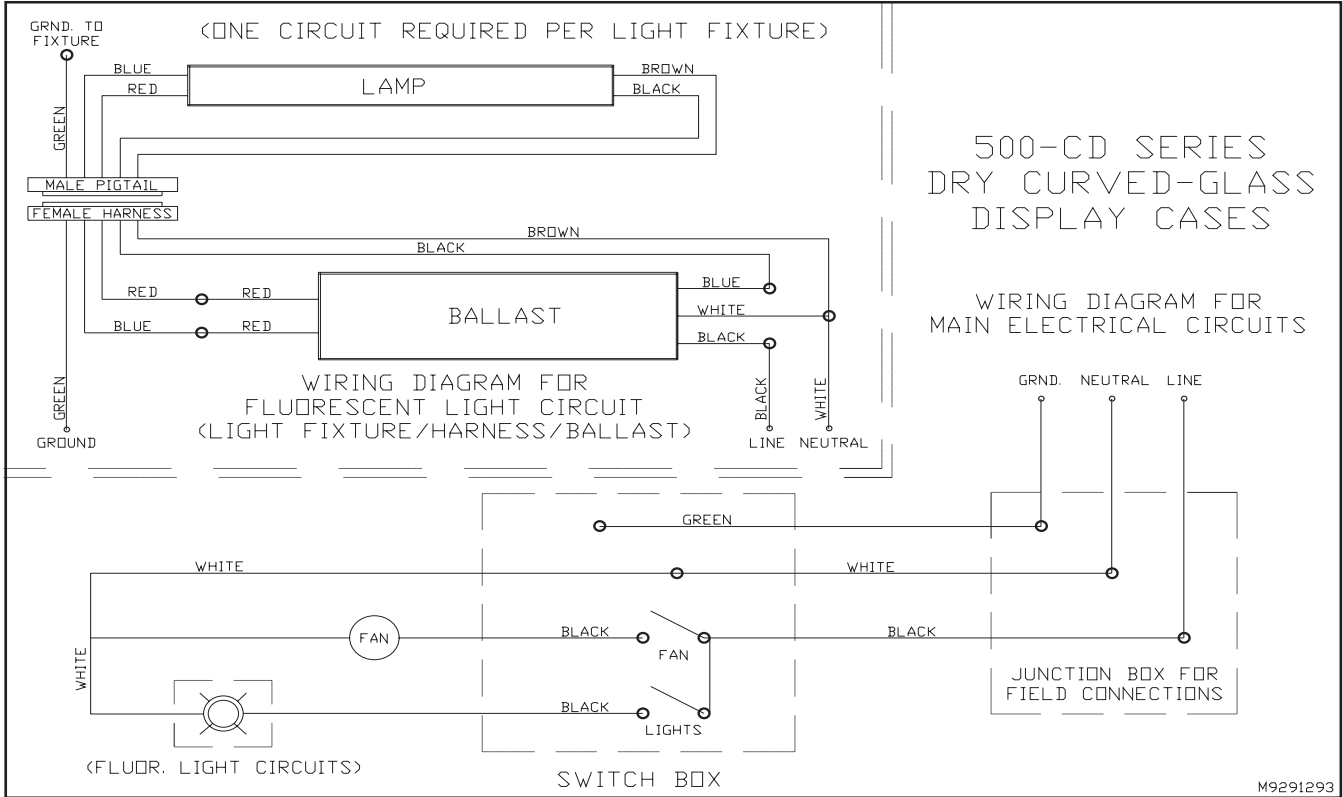

WIRING: 500 CH

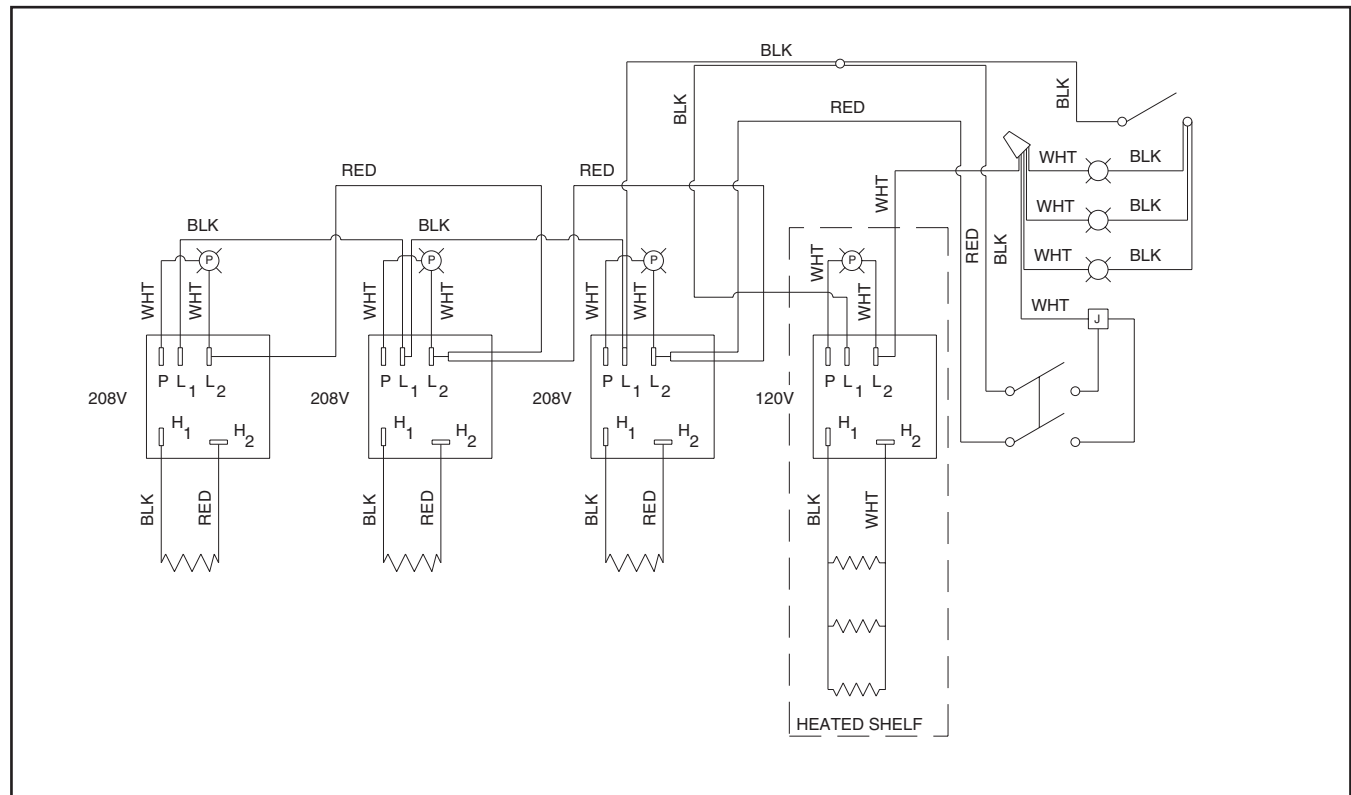

REPLACEMENT PARTS LIST FOR 537-CD

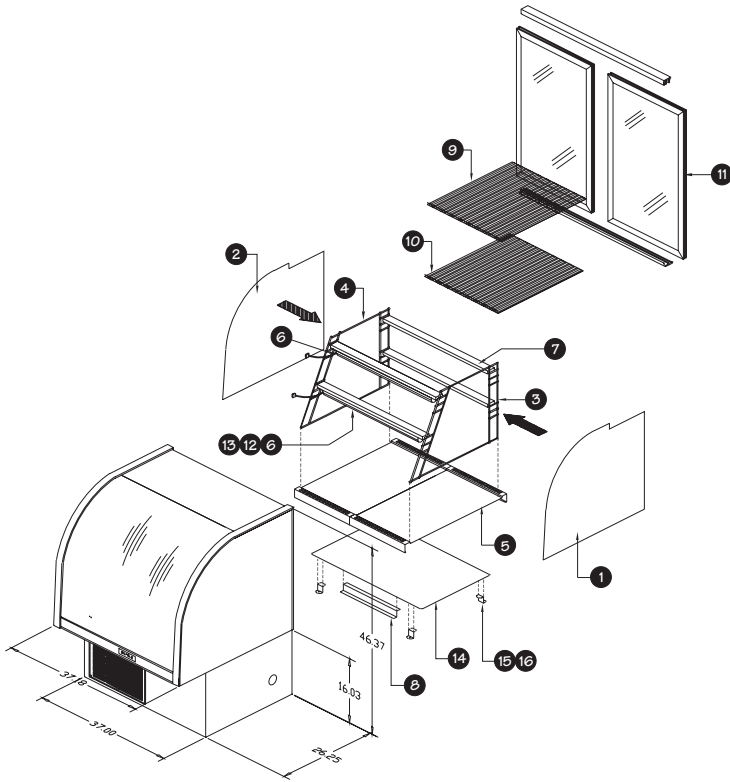

KEY	QUANTITY	DELFIELD PART#	DESCRIPTION
1	1	001-3133	mirror, acrylic, RH, 500-CD
2	1	001-3134	mirror, acrylic, LH, 500-CD
3	1	397-8121	holder, adj. shelf, RH
4	1	397-8120	holder, adj. shelf, LH
5	2	001-5285	diffuser, air 537-CD/CR
6	2	XMK00127	fixture, flour. light, 24 remote
7	4	001-5407	support, shelf, 537-CD/CR
8	2	001-5026	clip, air diffuser, 537-CD
9	1	397-8137	shelf, adjustable, 21" x 33"
10	1	397-8138	shelf, adjustable, 26" x 33"
11	1	323-7490	door set, with lock, 537-CD/CR
12	4	932-1095	stud, threaded, s/s, 1/4-20 x .75
13	4	932-1401	nut, 1/4-20, locking

Please Note: Items not shown on exploded view are listed on page 17.
Door locks #323-3986 & door keys #323-3988

REPLACEMENT PARTS LIST FOR 549-CD

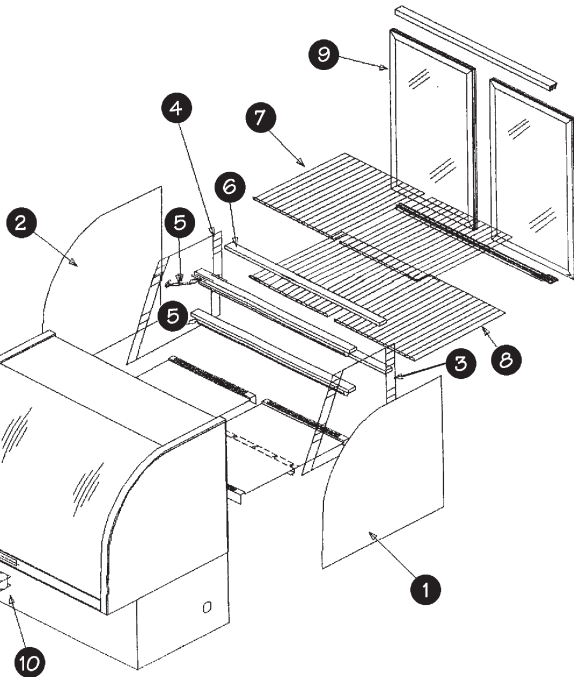

KEY	QUANTITY	DELFIELD PART#	DESCRIPTION
1	1	001-3133	mirror, acrylic, RH, 500-CD
2	1	001-3134	mirror, acrylic, LH, 500-CD
3	1	397-8121	holder, adj. shelf, RH
4	1	397-8120	holder, adj. shelf, LH
5	2	XMK00128	fixture, flour. light, 36 remote
6	4	001-5235	shelf support
7	2	397-8122	shelf, top
8	2	397-8123	shelf, bottom
9	1	323-4697	door assembly, with lock
10	1	216-2677	fan, axial

Please Note: Items not shown on exploded view are listed on page 17.
Door locks #323-3986 & door keys #323-3988

REPLACEMENT PARTS LIST FOR 561-CD

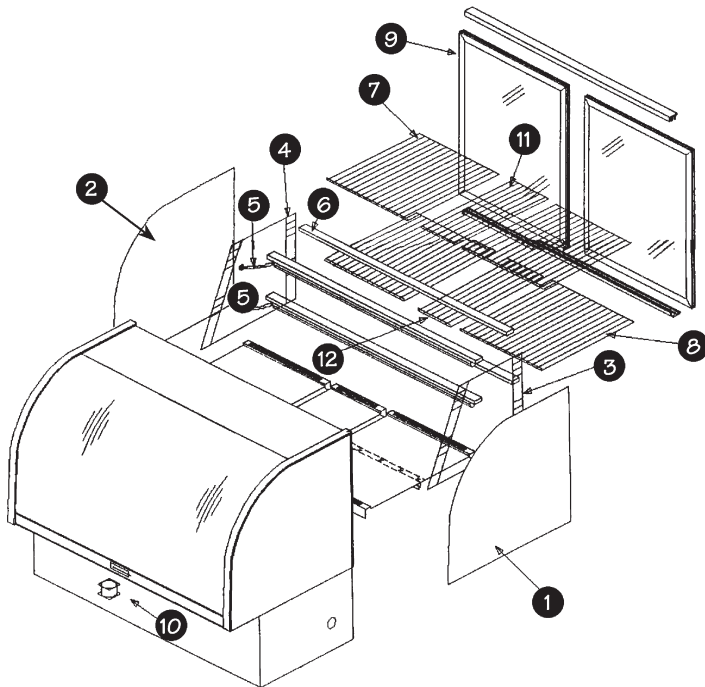

KEY	QUANTITY	DELFIELD PART#	DESCRIPTION
1	1	001-3133	mirror, acrylic, RH, 500-CD
2	1	001-3134	mirror, acrylic, LH, 500-CD
3	1	397-8121	holder, adj. shelf, RH
4	1	397-8120	holder, adj. shelf, LH
5	2	XMK00129	fixture, flour. light, 48 remote
6	4	001-5277	shelf support
7	2	397-8122	shelf, top
8	2	397-8123	shelf, bottom
9	1	323-4698	door assembly, PIKE, with lock
10	1	216-2677	fan, axial
11	1	397-8125	shelf, top center
12	1	397-8126	shelf, bottom center

Please Note: Items not shown on exploded view are listed on page 17.
 Door locks #323-3986 & door keys #323-3988

REPLACEMENT PARTS LIST FOR 573-CD

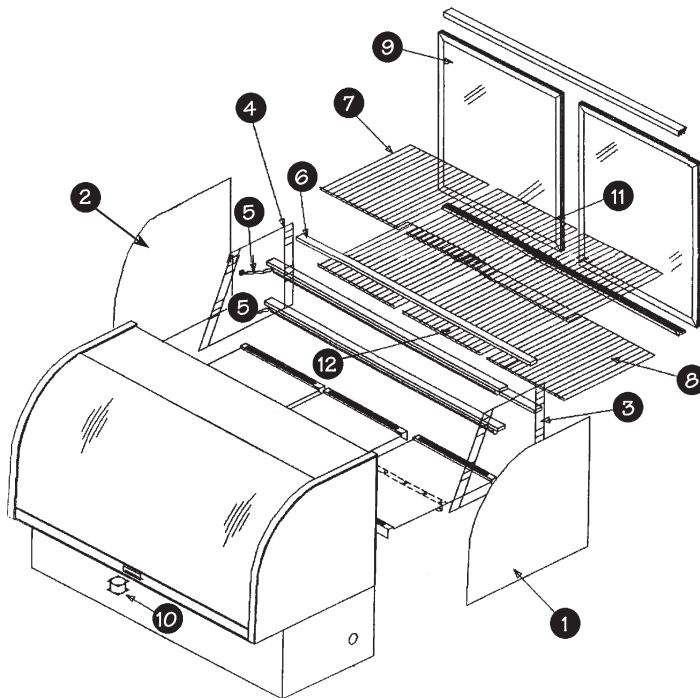

KEY	QUANTITY	DELFIELD PART#	DESCRIPTION
1	1	001-3133	mirror, acrylic, RH, 500-CD
2	1	001-3134	mirror, acrylic, LH, 500-CD
3	1	397-8121	holder, adj. shelf, RH
4	1	397-8120	holder, adj. shelf, LH
5	2	XMK00130	fixture, flour. light, 60 remote
6	4	001-5295	shelf support
7	2	397-8122	shelf, top
8	2	397-8123	shelf, bottom
9	1	323-4699	door assembly, PIKE, with lock
10	1	216-2677	fan, axial
11	1	397-8127	shelf, top center
12	1	397-8128	shelf, bottom center

Please Note: Items not shown on exploded view are listed on page 17.
 Door locks #323-3986 & Pike door keys #323-3988

REPLACEMENT PARTS LIST FOR 537CR/CRR

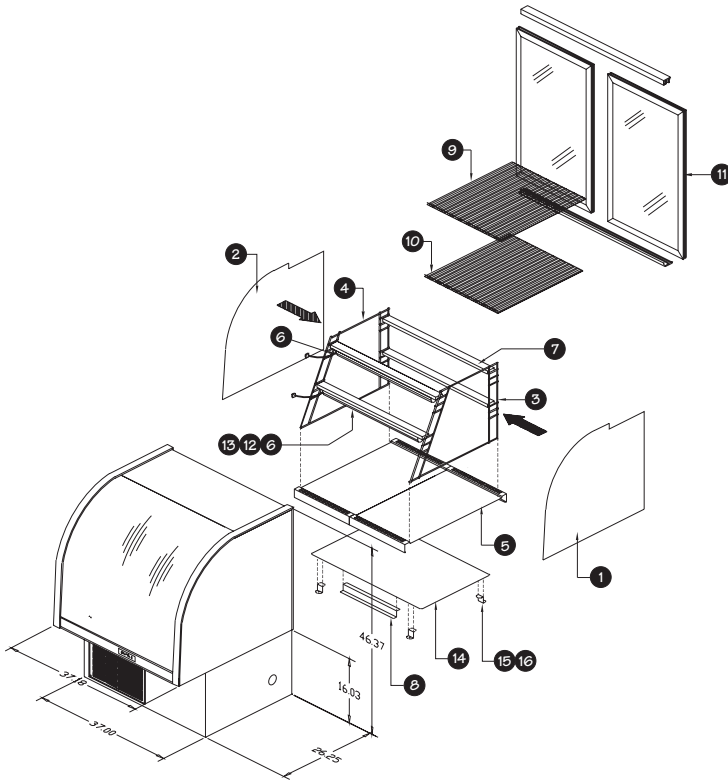

KEY	QUANTITY	DELFIELD PART#	DESCRIPTION
1	1	001-3131	mirror, acrylic, RH, 500-CR
2	1	001-3132	mirror, acrylic, LH, 500-CR
3	1	397-8121	holder, adj. shelf, RH
4	1	397-8120	holder, adj. shelf, LH
5	2	001-5285	diffuser, air 537-CD/CR
6	2	XMK00127	fixture, flour. light, 24 remote
7	4	001-5407	support, shelf, 537-CD/CR
8	1	001-5407	divider, air flow, 537-CR
9	1	397-8137	shelf, adjustable, 21" x 33"
10	1	397-8138	shelf, adjustable, 26" x 33"
11	1	323-7490	door set, with lock, 537-CD/CR
12	4	932-1095	stud, threaded, s/s, 1/4-20 x .75
13	4	932-1401	nut, 1/4-20, locking
14	1	001-5422	cover, coil, 537-CR
15	4	001-5252	clip, holding, coil cover
16	4	932-1238	screw, #8 x .75, H/N-P-TR-A

Please Note: Items not shown on exploded view are listed on page 17.

Door locks #323-3986 & door keys #323-3988

REPLACEMENT PARTS LIST FOR 549-CR/CRR

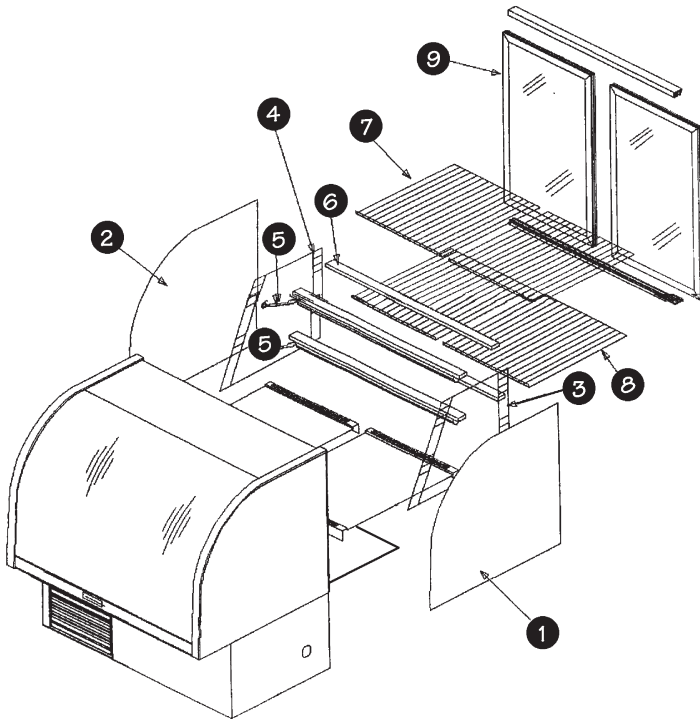

KEY	QUANTITY	DELFIELD PART#	DESCRIPTION
1	1	001-3133	mirror, acrylic, RH
2	1	001-3132	mirror, acrylic, LH
3	1	397-8121	holder, adj. shelf, RH
4	1	397-8120	holder, adj. shelf, LH
5	2	XMK00128	fixture, flour. light, 36 remote
6	4	001-5235	shelf support
7	2	397-8122	shelf, top
8	2	397-8123	shelf, bottom
9	1	323-4697	door assembly, with lock

Please Note: Items not shown on exploded view are listed on page 17.

Door locks #323-3986 & door keys #323-3988

REPLACEMENT PARTS LIST FOR 561-CR/CRR

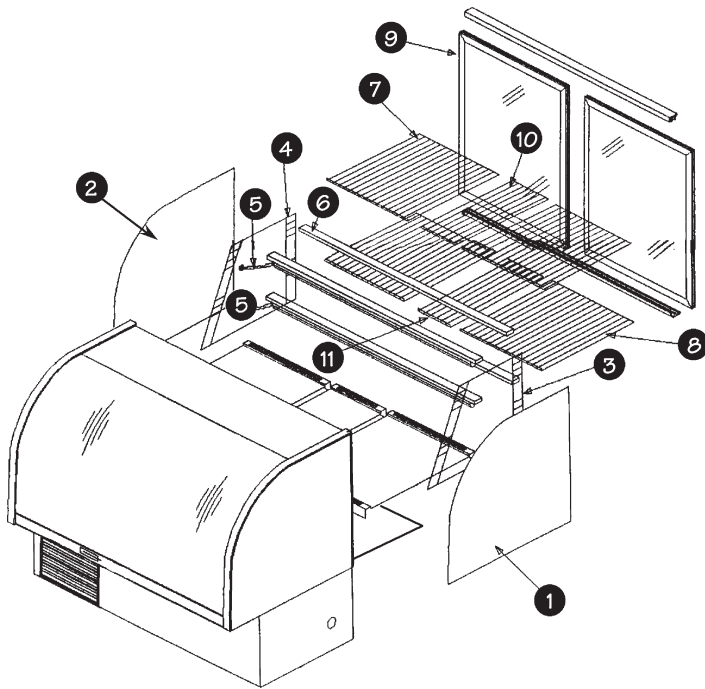

KEY	QUANTITY	DELFIELD PART#	DESCRIPTION
1	1	001-3133	mirror, acrylic, RH
2	1	001-3132	mirror, acrylic, LH
3	1	397-8121	holder, adj. shelf, RH
4	1	397-8120	holder, adj. shelf, LH
5	2	XMK00129	fixture, flour. light, 48 remote
6	4	001-5277	shelf support
7	2	397-8122	shelf, top
8	2	397-8123	shelf, bottom
9	1	323-4698	door assembly, PIKE, with lock
10	1	397-8125	shelf, top center
11	1	397-8126	shelf, bottom center

Please Note: Items not shown on exploded view are listed on page 17.
 Door locks #323-3986 & door keys #323-3988

REPLACEMENT PARTS LIST FOR 573-CR/CRR

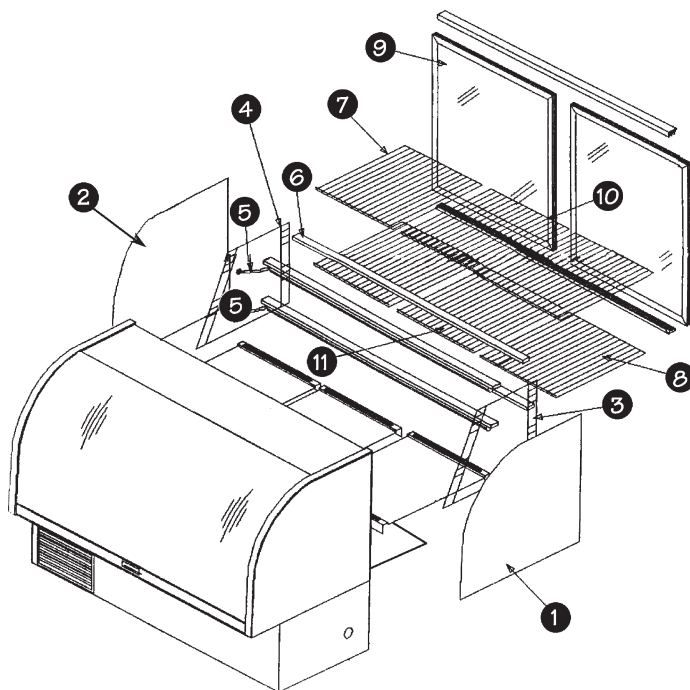

KEY	QUANTITY	DELFIELD PART#	DESCRIPTION
1	1	001-3133	mirror, acrylic, RH
2	1	001-3132	mirror, acrylic, LH
3	1	397-8121	holder, adj. shelf, RH
4	1	397-8120	holder, adj. shelf, LH
5	2	XMK00130	fixture, flour. light, 60 remote
6	4	001-5295	shelf support
7	2	397-8122	shelf, top
8	2	397-8123	shelf, bottom
9	1	323-4699	door assembly, PIKE, with lock
10	1	397-8127	shelf, top center
11	1	397-8128	shelf, bottom center

Please Note: Items not shown on exploded view are listed on page 17.
 Door locks #323-3986 & door keys #323-3988

REPLACEMENT PARTS LIST FOR 549-CH

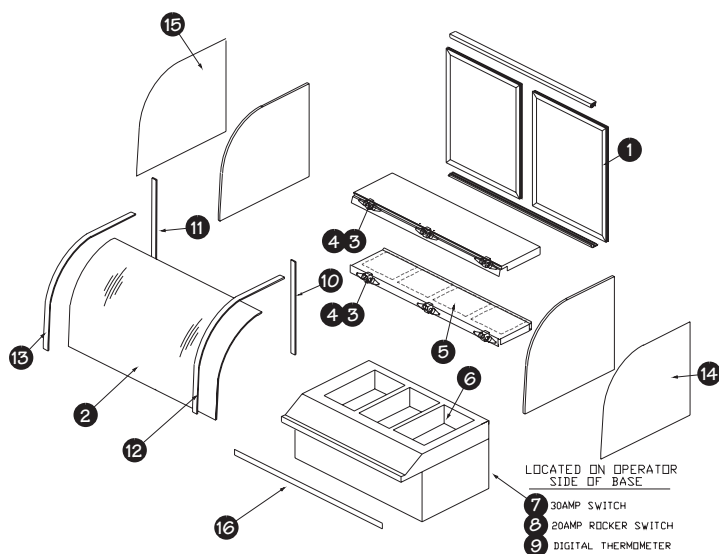

KEY	DELFIELD PART#	DESCRIPTION
1	323-4055	door set, 49" curved glass
2	345-5439	glass, curved, 1" insulated, 47"
3	219-3959	bulb, 25W, Teflon coated, clear
4	219-3960	lamp holder, twin-threaded
5	219-3970	heater, pad, 115V/90W
6	XMK00106	warmer, food, 208V, no drain
7	219-4212	switch, 30A 120/277V
8	219-0154	switch, rocker, 20A/125V, 15A/250V
9	351-6059	thermometer, digital, solar/batt
10	105-0183	extrusion, polyethylene, blk, vertical, RH
11	105-0173	extrusion, polyethylene, blk, vertical, LH
12	105-0184	extrusion, polyethylene, blk, curved, RH
13	105-0174	extrusion, polyethylene, blk, curved, LH
14	001-5414	trim, side, exterior, RH
15	001-5415	trim, side, exterior, LH
16	001-6855	trim, front, laminate

REPLACEMENT PARTS LIST FOR 561-CH

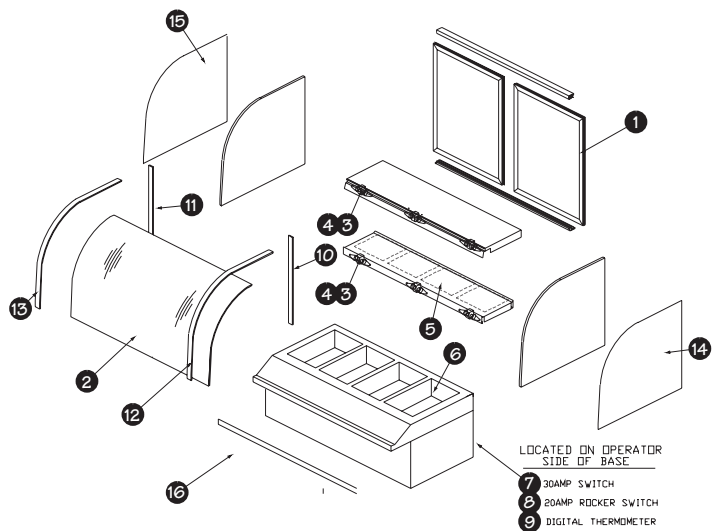

KEY	DELFIELD PART#	DESCRIPTION
1	323-4068	door set, 61" curved glass
2	345-5441	glass, curved, 1" insulated, 59"
3	219-3959	bulb, 25W, Teflon coated, clear
4	219-3960	lamp holder, twin-threaded
5	219-3970	heater, pad, 115V/90W
6	XMK00106	warmer, food, 208V, no drain
7	219-4212	switch, 30A 120/277V
8	219-0154	switch, rocker, 20A/125V, 15A/250V
9	351-6059	thermometer, digital, solar/batt
10	105-0183	extrusion, polyethylene, blk, vertical, RH
11	105-0173	extrusion, polyethylene, blk, vertical, LH
12	105-0184	extrusion, polyethylene, blk, curved, RH
13	105-0174	extrusion, polyethylene, blk, curved, LH
14	001-5414	trim, side, exterior, RH
15	001-5415	trim, side, exterior, LH
16	001-6866	trim, front, laminate

REPLACEMENT PARTS LIST FOR 573-CH

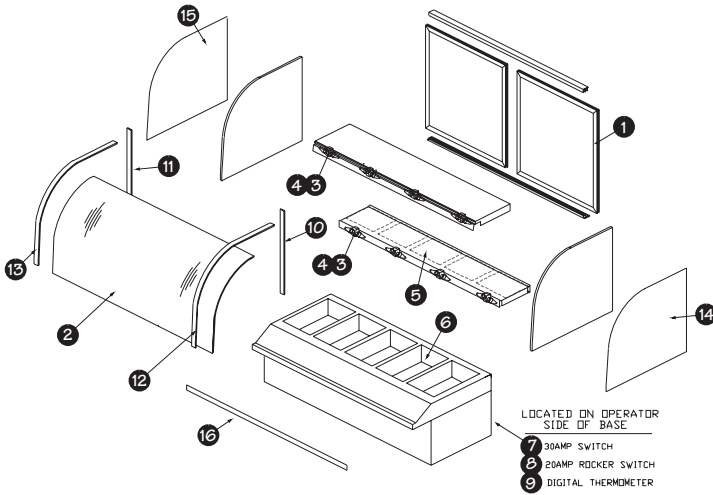

KEY	DELFIELD PART#	DESCRIPTION
1	323-4069	door set, 73" curved glass
2	345-5443	glass, curved, 1" insulated, 71"
3	219-3959	bulb, 25W, Teflon coated, clear
4	219-3960	lamp holder, twin-threaded
5	219-3970	heater, pad, 115V/90W
6	XMK00106	warmer, food, 208V, no drain
7	219-4212	switch, 30A 120/277V
8	219-0154	switch, rocker, 20A/125V, 15A/250V
9	351-6059	thermometer, digital, solar/batt
10	105-0183	extrusion, polyethylene, blk, vertical, RH
11	105-0173	extrusion, polyethylene, blk, vertical, LH
12	105-0184	extrusion, polyethylene, blk, curved, RH
13	105-0174	extrusion, polyethylene, blk, curved, LH
14	001-5414	trim, side, exterior, RH
15	001-5415	trim, side, exterior, LH
16	001-6867	trim, front, laminate

REPLACEMENT PARTS LIST FOR 549-OR

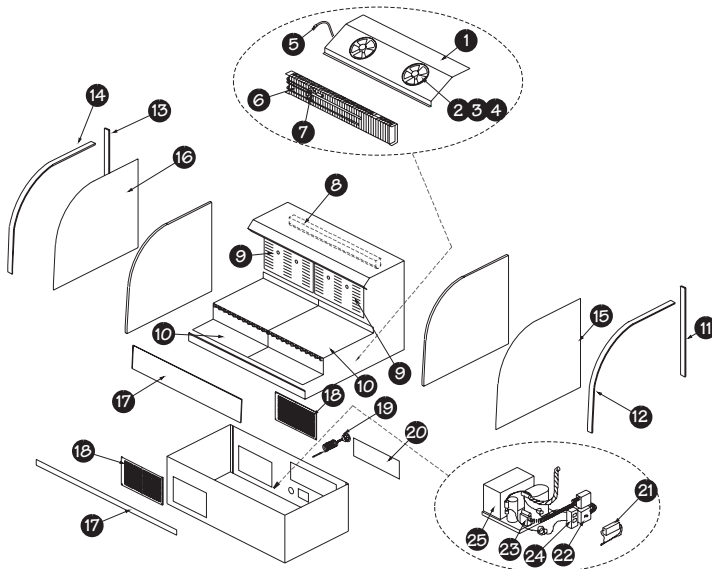

KEY	DELFIELD PART#	DESCRIPTION
1	001-5558	baffle, fan 49"
2	216-2667	motor, fan, morrill
3	351-6075	blade, fan, 7" dia., aluminum
4	397-8070	bracket, fan motor
5	218-2414	harness, fan motor, 78"
6	351-6097	coil, evaporator, custom, 49"
7	351-6273	valve, expansion, 1/4, HI, 404A
8	XMK-00132	fixture, fluorescent light, 36"
9	001-5554	back, interior, louvered
10	001-5555	diffuser, air, LH & RH
11	105-0183	extrusion, polyethylene, blk, vert, RH
12	105-0173	extrusion, polyethylene, blk, vert, LH
13	105-0184	extrusion, polyethylene, blk, curved, RH
14	105-0174	extrusion, polyethylene, blk, curved, LH
15	001-5414	trim, side, exterior, RH
16	001-5415	trim, side, exterior LH
17	001-6855	trim, front, laminate, 549
18	001-5278	louvers, s/s, 15 x 17
19	351-6038	thermometer, dial
20	001-5243	panel, access
21	219-3903	ballast, rapid start, 36" lamp
22	219-3919	switch, 15A/120V
23	351-6247	control, pressure, high
24	509-0025	control, temperature, -30-100
25	352-6731	condensing unit, 1/2 hp, R-404A, med

FLUORESCENT LIGHT

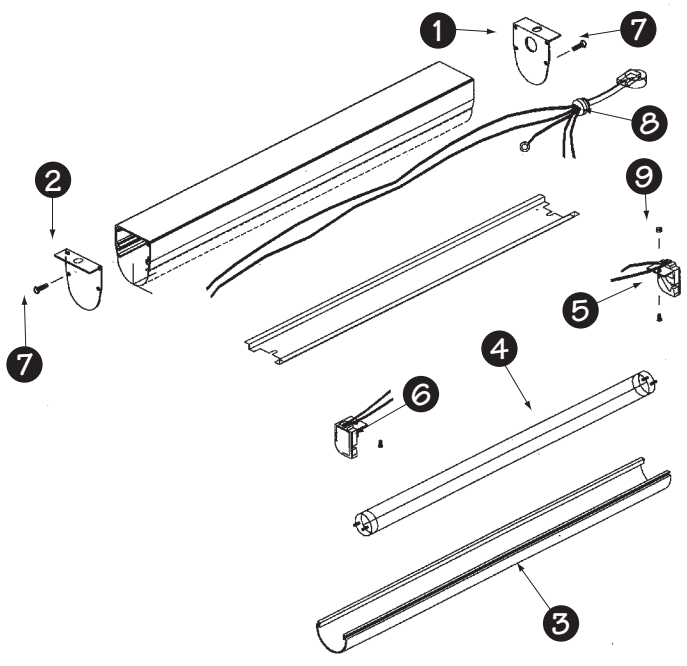

KEY	DELFIELD PART#	DESCRIPTION
1	SMK00571	cap, end, top mtg, pigtail, -rem.
2	SMK00572	cap, end, top mtg, blank, -rem.
3	170-1045	diffuser, fluor. light, 24"
	170-1046	diffuser, fluor. light, 36"
	170-1047	diffuser, fluor. light, 48"
	170-1054	diffuser, fluor. light, 60"
4	219-3906	lamp, fluorescent, 24"
	219-3907	lamp, fluorescent, 36"
	219-3908	lamp, fluorescent, 48"
	219-3909	lamp, fluorescent, 60"
5	219-3939	lamp holder, left
6	219-3940	lamp holder, right
7	932-1266	screw, #8-32 x .50
8	218-3613	pigtail, male, 3.5", rem. ballast
	218-3595	pigtail, male, 9", rem. ballast
9	932-1010	nut, hex, starlock, s/s, #6-32

*Refer to the exploded view of unit for a complete assembly part number

Door Assembly

KEY	DELFIELD PART#	DESCRIPTION
	323-7490	complete assembly, 537-CD/CR/CRR
	323-4697	complete assembly, 549-CD/CR/CRR
	323-4055	complete assembly, 549-CH
	323-4698	complete assembly, 561-CD
	323-4699	complete assembly, 573-CD
1	323-4636	single roller, 537, 549 & 561
	323-4637	double roller, 573
2	order by size	bumper gasket, 241/8 & 537
	323-3936	bumper gasket, 245/32, 549, 561 & 573
3	order by size	wiper gasket, 537
	323-3936	wiper gasket, 2223/32, 549, 561 & 573
4	323-3947	spring 12", green, 537
	323-3949	spring 12", 549
	323-3945	spring 23", gold, 561
	323-3946	spring 30", gold, 573
5	order by size	bottom track, 34 3/16, 537, black
	323-3904	bottom track, 46 3/16, 549, black
	order by size	bottom track, 46 3/16, 549-CH, black
	323-3909	bottom track, 58 3/16, 561, black
	323-3912	bottom track, 70 3/16, 573, black
6	order by size	top track, 34 3/16, 537, black
	323-3904	top track, 46 3/16, 549, black
	323-3922	top track, 58 3/16, 561
	order by size	Alum. top track, 46 3/16, 549-CH
	323-3925	top track, 70 3/16, 573

Please Note: Gaskets & tracks order by dimensions • Plastic door glides order by description reference #323-4055, 549-CH

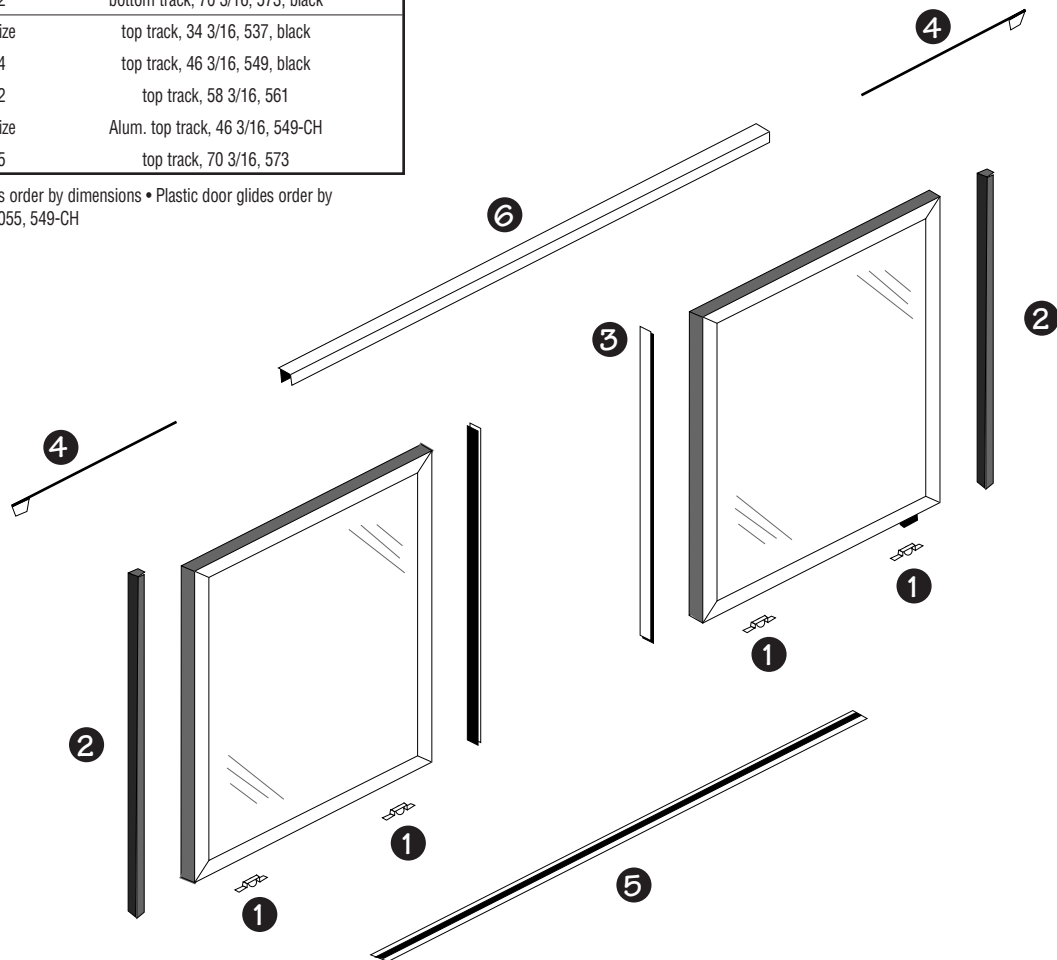

COMPRESSOR/COIL ASSEMBLY 537/549/561-CR/CRR

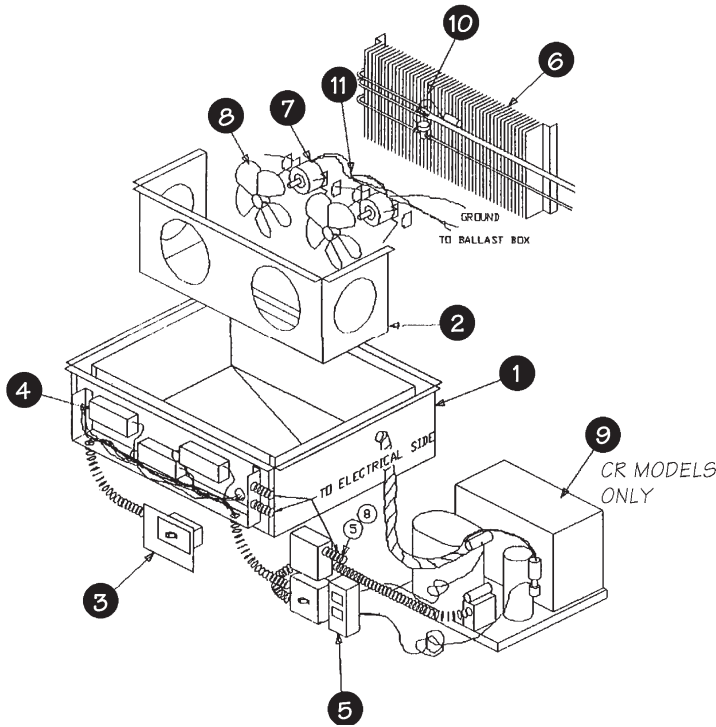

KEY	DELFIELD PART#	DESCRIPTION
1	010-1916	coil pan assembly
2	001-5251	bracket, fan mounting
	001-5417	bracket, fan mounting (537-CR)
3	219-3919	switch, toggle, SPST
4	219-3903	ballast, rapid start (549 & 537-CR)
	219-3904	ballast, rapid start (561)
5	219-3942	control, SPST
	219-3927	control, SPST (537-CR)
6	351-6231	evaporator coil, 404A
	351-6072	evaporator coil, 404A (537-CR)
7	216-2667	motor, fan, 1450 rpm, CW (537, 549 & 561)
8	351-6184	blade, fan, 7" plastic, CW
9	352-6729	condensing unit, 1/2 h.p., 404A (549-CR)
	352-6746	condensing unit, 1/3 h.p., 404A (537-CR)
	352-6732	condensing unit, 3/4 h.p., 404A (561-CR)
10	351-6084	valve, expansion, 1/2", 404A
11	218-3445	harness, evaporator fan

COMPRESSOR/COIL ASSEMBLY 573-CR/CRR

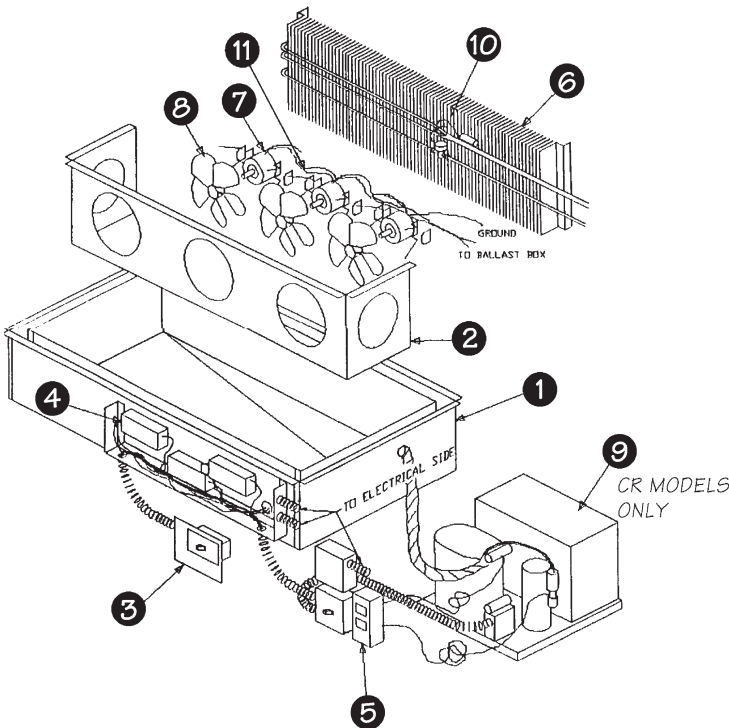

KEY	DELFIELD PART#	DESCRIPTION
1	010-1926	coil pan assembly
2	001-5292	bracket, fan mounting
3	219-3919	switch, toggle, SPST
4	219-3905	ballast, rapid start
5	219-3942	control, SPST
6	351-6246	evaporator coil, 404A
7	216-2667	motor, fan, 1450 rpm, CW
8	351-6184	blade, fan, 7" plastic, CW
9	352-6732	condensing unit, 3/4 h.p., 404A (573-CR only)
10	351-6084	valve, expansion, 1/2", 404A
11	218-3445	harness, evaporator fan

DELFIELD FOOD WELL (DFW) ASSEMBLY: WITH INFINITE CONTROL

For 500-CH Heated Units

KEY	DELFIELD PART#	DESCRIPTION
	XMK00106	Complete assembly, infinite w/o drain
1	GMK00061	Deflector plate
2	GMK00062	Bottom cover
3	016-0014	Food well, with drain
4	932-1353	Screw
5	219-4007	Element
6	932-1379	Screws (2)
7	343-4663	Insulation
8	219-4335	Thermostat non-adjustable
9	932-1007	Screw
10	GMK00063	Drain cover
11	932-1007	Screws (2)
12	219-4110	Infinite control, 240V
13	323-4557	Infinite control knob
14	219-4095	Pilot light, amber

NOTE: If you need four or more component parts, you must buy a complete assembly.



INFINITE CONTROL KNOB

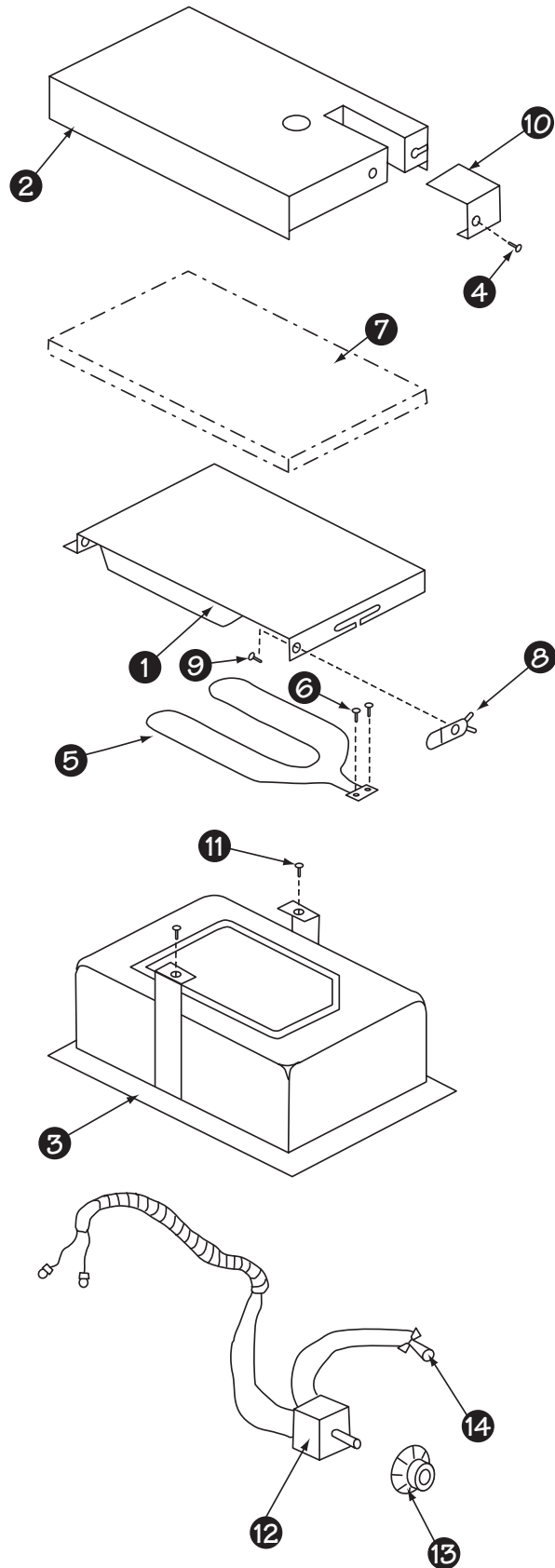

REPLACEMENT PARTS LIST — NOT SHOWN ON EXPLODED VIEWS

DELFIELD PART#	DESCRIPTION
CR & CRR MODELS (MISC. PARTS)	
Harness, wiring-female, 84"	218-3596
Glass, curved, 1", insulated, 35" (537)	345-5319
Glass, curved, 1", insulated, 47" (549)	345-5439
Glass, curved, 1", insulated, 59" (561)	345-5441
Glass, curved, 1", insulated, 71" (573)	345-5443
Foot, leveler, adj., 1/2-13	323-4696
Fixture, fluorescent light, 24" remote, top light (537)	..XMK00131
Fixture, fluorescent light, 36" remote, top light (549)	..XMK00132
Fixture, fluorescent light, 48" remote, top light (561)	..XMK00133
Fixture, fluorescent light, 60" remote, top light (573)	..XMK00134
Louver, s/s, 15 x 17	001-5278
Louver, s/s, 15 x 23	001-5279
Harness, light/fan motor, 78"	218-3414
Switch, 15A/120V, SPST, ivory	219-3919
Holder, adj. shelf, beige, RH	397-8121
Holder, adj. shelf, beige, LH	397-8120
Control, pressure, dual	219-3942
Bracket, fan motor	397-8070
Blade, fan, 7" dia., Lexan, clear	351-6184
Harness, evaporator fan	218-3445
Support, shelf, (549-CR)	001-5235
Shelf, top/end, adj., 21 x 22.5	397-8122
Shelf, bottom/end, adj., 26 x 22.5	397-8123
Door set, 49" disp. case, with lock	323-4697
Door set, 61" disp. case, with lock	323-4698
Shelf, top/center, adj., 21 x 12	397-8125
Shelf, bottom/center, adj., 26 x 12	397-8126

CD MODELS (MISC. PARTS)

Harness, wiring-female, 84"	218-3596
Glass, curved, .25", insulated, 35" (537)	345-5400
Glass, curved, .25", insulated, 47" (549)	345-5440
Glass, curved, .25", insulated, 59" (561)	345-5442
Glass, curved, .25", insulated, 71" (573)	345-5444
Fixture, fluorescent light, 24" remote, top light (537)	..XMK00131
Fixture, fluorescent light, 36" remote, top light (549)	..XMK00132
Fixture, fluorescent light, 48" remote, top light (561)	..XMK00133
Fixture, fluorescent light, 60" remote, top light (573)	..XMK00134
Foot, leveler, adj., 1/2-13	323-4696
Switch, 15A/120V, (2) SPST, ivory	219-3918
Holder, adj. shelf, beige, RH	397-8121
Holder, adj. shelf, beige, LH	397-8120
Pigtail, male, 9", rem. ballast	218-3595
Support, shelf, (549)	001-5235
Shelf, bottom/end, adj., 21 x 22.5 (549 & 561)	397-8122
Shelf, adjustable, 21 x 33 (537)	397-8137
Shelf, top, center, adj. 21 x 24 (573)	397-8127
Shelf, bottom/end, adj., 26 x 22.5 (549 & 561)	397-8123
Shelf, adjustable, 26 x 33 (537)	397-8138
Shelf, bottom, center, adj. 26 x 24 (573)	397-8128

DELFIELD PART#	DESCRIPTION
OR MODELS (MISC. PARTS)	
Motor, evaporator	216-2667
Blade, fan, 7" dia., CW, 20 deg, alum	351-6075
Harness, light/fan motor, 78"	218-3414
Coil, evap., customer, 49"	351-6097
Cond. unit, 1/2 h.p., R-404A, med	352-6731
Control, temperature, -30-100%D	509-0025
Valve, Expansion, 1/4, R-404A	351-6273
Ballast, rapid start, 36" lamp	219-3903
Switch, 15A/120V, SPST, ivory	219-3919
Timer, 24 hours, clock face	219-4345
Harness, evaporator fan	218-3445
Bracket, fan motor	397-8070
Louver, s/s, 15 x 17	001-5278
Shelf, Lexan, .5" x 10" x 45.5"	354-5339
Dial, Thermometer	351-6038
CH Models (misc. parts)	
Lamp holder, twin-threaded	219-3960
Bulb, 25W, Teflon coating, clear	219-3959
Heater, pad, 115V/90W	219-3970
Thermostat, nonadjustable, 480°F	219-4335
Thermometer/digital, solar/batt	351-6059
Switch, rocker, 20A/125V, 15A/250V	219-0154
Switch, 30A, 120/277V	219-4212

BALLASTS

120V ballast (537)	219-3902
120V ballast (549)	219-3903
120V ballast (561)	219-3904
120V ballast (573)	219-3905
220V ballast	special order



STANDARD LABOR GUIDELINES TO REPAIR OR REPLACE PARTS ON DELFIELD EQUIPMENT

Advice and recommendations given by Delfield Service Technicians do not constitute or guarantee any special coverage.

- A maximum of 1-hour is allowed to **diagnose a defective component**.
- A maximum of 1-hour is allowed for **retrieval of parts** not in stock.
- A maximum **travel distance** of 100 miles round trip and 2-hours will be reimbursed.
- Overtime, installation/start-up, normal control adjustments, general maintenance, glass breakage, freight damage, and/or correcting and end-user installation error will not be reimbursed under warranty unless pre-approved with a **Service Work Authorization** from Delfield. You must submit the number with the service claim.

LABOR OF 1-HOUR IS ALLOWED TO REPLACE:

- Thermostat
- Infinite Switch
- Door Jamb Switch
- Solenoid Coil
- Hi-limit/Thermal Protector Switch
- Fan Delay/Defrost Termination Switch
- Compressor Start Components and Overload Protector
- Defrost Timer
- Thermometer
- Gear Box
- Contactor/Relay
- Transformer
- Evaporator/Condenser Fan Motor and Blade
- Circulating Fan Motor and Blade
- Microprocessor Control
- Water Level Sensor/Probe
- Door Hinges, Locks, and Gaskets
- Condensate Element
- Springs/Lowerator

LABOR OF 2 HOURS TO REPLACE:

- Drawer Tracks/Cartridges
- Pressure Control
- Solenoid Valve
- Defrost Element
- Heating Element
- Locate/Repair Leak

LABOR OF 3 HOURS TO REPLACE:

- EPR or CPR Valve
- Expansion Valve
- Condenser or Evaporator Coil

LABOR OF 4 HOURS TO REPLACE

- Compressor

This includes recovery of refrigerant and leak check.

\$35.00 maximum reimbursement for refrigerant recovery (includes recovery machine, pump, torch, oil, flux, minor fittings, solder, brazing rod, nitrogen, or similar fees.)

REFRIGERANTS

- R22 A maximum of \$4.00/lb. or 25¢/oz. will be reimbursed.
- R134A A maximum of \$5.00/lb. or 31¢/oz. will be reimbursed.
- R404A A maximum of \$12.00/lb. or 75¢/oz. will be reimbursed.

STANDARD ONE YEAR WARRANTY (ONE YEAR PARTS, 90 DAYS LABOR.)

The Delfield Company (“Delfield”) warrants to the Original Purchaser of the Delfield product (herein called the “Unit”) that such Unit, and all parts thereof, will be free from defects in material and workmanship under normal use and service for a period of one (1) year from the date of shipment of the Unit to the Original Purchaser **or, if the Original Purchaser returns the warranty card completely filled out including the date of installation within thirty (30) days of receipt of the Unit, one (1) year from the date of installation.** During this one year warranty period, Delfield will repair or replace any defective part or portion thereof returned to Delfield by the Original Purchaser which Delfield determines was defective due to faulty material or workmanship. The Original purchaser will pay all labor, crating, freight and related costs incurred in the removal of the Unit of defective component and shipment to Delfield, except that during a period of either ninety (90) days from the date of shipment of the Unit to the Original Purchaser or, if the Original Purchaser returns the warranty card completely filled out including the date of installation within thirty (30) days of receipt of the Unit, ninety (90) days from the date of installation Delfield will pay all related labor costs. Delfield will pay the return costs if the Unit or part thereof was defective.

The term “Original Purchaser” as used herein means that person, firm, association, or corporation for whom the Unit was originally installed.

This warranty does not apply to any Unit or part thereof that has been subjected to misuse, neglect, alteration, or accident, such as accidental damage to the exterior finish, operated contrary to the recommendations specified by Delfield; or repaired or altered by anyone other than Delfield in any way so as to, in Delfield’s sole judgement, affect its quality or efficiency. This warranty does not apply to any Unit that has been moved from the location where it was originally installed. This warranty also does not cover the refrigerator drier or the light bulbs used in the Unit. **The warranty is subject to the user’s normal maintenance and care responsibility as set forth in the Service and Installation Manual, such as cleaning the condenser coil, and is in lieu of all other obligations of Delfield. Delfield neither assumes, nor authorizes any other person to assume for Delfield, any other liability in connection with Delfield’s products.**

Removal or defacement of the original Serial Number or Model Number from any Unit shall be deemed to release Delfield from all obligations hereunder or any other obligations, express or implied.

Parts furnished by suppliers to Delfield are guaranteed by Delfield only to the extent of the original manufacturer’s express warranty to Delfield. Failure of the Original Purchaser to receive such manufacturer’s express warranty to Delfield. Failure of the Original Purchaser to receive such manufacturer’s warranty shall in no way create any warranty, expressed or implied, or any other obligation or liability on Delfield’s part in respect thereof.

IF THE CUSTOMER IS USING A PART THAT RESULTS IN A VOIDED WARRANTY AND A DELFIELD AUTHORIZED REPRESENTATIVE TRAVELS TO THE INSTALLATION ADDRESS TO PERFORM WARRANTY SERVICE, THE SERVICE REPRESENTATIVE WILL ADVISE CUSTOMER THE WARRANTY IS VOID. SUCH SERVICE CALLS WILL BE BILLED TO CUSTOMER AT THE AUTHORIZED SERVICE CENTER’S THEN APPLICABLE TIME AND MATERIALS RATES. CONSIDER: CUSTOMER MAY INITIATE A SERVICE AGREEMENT WITHOUT PARTS COVERAGE.

If shipment of a replacement part is requested prior to the arrival in the Delfield factory of the part claimed to be defective, the Original Purchaser must accept delivery of the replacement part of a C.O.D.

basis, with credit being issued after the part has been received and inspected at Delfield’s plant and determined by Delfield to be within this warranty.

Under no condition does this warranty give the Original Purchaser the right to replace the defective Unit with a complete Unit of the same manufacturer or of another make. Unless authorized by Delfield in writing, this warranty does not permit the replacement of any part, including the motor-compressor, to be made with the part of another make or manufacturer.

No claims can be made under this warranty for spoilage of any products for any reason, including system failure.

The installation contractor shall be responsible for building access, entrance and field conditions to insure sufficient clearance to allow any hood(s), vent(s), or Unit(s) if necessary, to be brought into the building. Delfield will not be responsible for structural changes or damages incurred during installation of the Unit or any exhaust system.

Delfield shall not be liable in any manner for any default or delay in performance hereunder caused by or resulting from any contingency beyond Delfield’s control, including, but not limited to, war, governmental restrictions or restraints, strike, lockouts, injunctions, fire, flood, acts of nature, short or reduced supply of raw materials, or discontinuance of the parts by the original part manufacturer.

Except as provided in any Additional Four Year Protection Plan, if applicable, and the Service Labor Contract, if applicable, the foregoing is exclusive and in lieu of all other warranties, whether written or oral, express or implied. This warranty supersedes and excludes any prior oral or written representations or warranties. Delfield expressly disclaims any implied warranties of merchantability, fitness for a particular purpose of compliance with any law, treaty, rule or regulation relating to the discharge of substances into the environment. The sole and exclusive remedies of any person relating to the Unit, and the full liability of Delfield for any breach of this warranty, will be as provided in this warranty.

Other than this Delfield Standard One Year Limited Warranty, any applicable Delfield Additional Four Year Protection Plan or applicable Delfield Service Labor Contract, the Original Purchaser agrees and acknowledges that no other warranties are offered or provided in connection with or for the unit or any other part thereof.

In no event will Delfield be liable for special, incidental or consequential damages, or for damages in the nature of penalties.

IF DURING THE WARRANTY PERIOD, CUSTOMER USES A PART FOR THIS DELFIELD EQUIPMENT OTHER THAN AN UNMODIFIED NEW OR RECYCLED PART PURCHASED DIRECTLY FROM DELFIELD OR ANY OF ITS AUTHORIZED SERVICE CENTERS AND/OR THE PART BEING USED IS MODIFIED FROM ITS ORIGINAL CONFIGURATION, THIS WARRANTY WILL BE VOID. FURTHER, DELFIELD AND ITS AFFILIATES WILL NOT BE LIABLE FOR ANY CLAIMS DAMAGES OR EXPENSES INCURRED BY THE CUSTOMER WHICH ARISE DIRECTLY OR INDIRECTLY, IN WHOLE OR IN PART, DUE TO THE INSTALLATION OF ANY MODIFIED PART AND/OR PART RECEIVED FROM AN UNAUTHORIZED SERVICE CENTER. If the warranty becomes void, Customer may purchase from Delfield, if available, a Service Agreement or service at the then current time and materials rate.

For more information on Delfield warranty’s log on and check out the service section of our web site at www.delfield.com.



ADDITIONAL FOUR YEAR PROTECTION PLAN (FOR MOTOR-COMPRESSOR ONLY)

Delfield Model#	Serial #	Installation Date

In addition to the Standard One Year Warranty on the Motor-Compressor contained in the above listed Delfield product (the "Unit"), The Delfield Company ("Delfield") also agrees to repair, or exchange with similar or interchangeable parts in design and capacity at Delfield's option, the defective Motor-Compressor contained in the Unit (the "Motor-Compressor"), or any part thereof, for the Original Purchaser only, at any time during the four (4) years following the initial one (1) year period commencing on the date of installation for the Original Purchaser. **Failure of the Original Purchaser to register the registration card containing the Original Purchasers name, address, date of installation, model number and serial number of the Unit containing the Motor-Compressor within 30 days from the date of installation shall void this warranty.** This additional warranty is only available if the Motor-Compressor is inoperative due to defects in material or factory workmanship, as determined by Delfield in its sole judgement and discretion. The Original Purchaser shall be responsible for returning the defective Motor-Compressor to Delfield prepaid, F.O.B. at the address shown on the back cover of this manual.

The term "Original Purchaser" as used herein means that person, firm, association, or corporation for whom the Unit was originally installed.

The term "Motor-Compressor" as used herein does not include unit base, air or water cooled condenser, receiver, electrical accessories such as relay, capacitors, refrigerant controls, or condenser fan/motor assembly. This warranty does not cover labor charges incidental to the replacement of parts. This warranty further does not include any equipment to which said condensing unit is connected, such as cooling coils, temperature controls or refrigerant metering devices. This warranty shall be void if the Motor-Compressor, in Delfield's sole judgement, has been subjected to misuse, neglect, alteration or accident, operated contrary to the recommendations specified by the Unit manufacturer, repaired or altered by anyone other than Delfield in any way so as, in Delfield's sole judgment, to affect its quality or efficiency or if the serial number has been altered, defaced or removed. This Warranty does not apply to a Motor-Compressor in any Unit that has been moved from the location where it was originally installed. The addition of methyl chloride to the condensing unit or refrigeration system shall void this warranty.

General Conditions

Delfield shall not be liable in any manner for any default or delay in performance hereunder caused by or resulting from any contingency beyond Delfield's control, including, but not limited to, war, governmental restrictions or restraints, strike, lockouts, injunctions, fire, flood, acts of nature, short or reduced supply of raw materials, or discontinuance of any part or the Motor-Compressor by the unit manufacturer.

Replacement of a defective Motor-Compressor is limited to one (1) Motor-Compressor by us during the four (4) year period. Delfield shall replace the Motor-Compressor at no charge.

This warranty does not give the Original Purchaser of the Motor-Compressor the right to purchase a complete replacement Motor-Compressor of the same make or of another make. It further does not permit the replacement to be made with a Motor-Compressor of another kind unless authorized by Delfield. In the event Delfield authorizes the Original Purchaser to purchase a replacement Motor-Compressor locally, only the wholesale cost of the Motor-Compressor is refundable.

Expressly excluded from this warranty are damages resulting from spoilage of goods.

Except as provided in any applicable Standard One Year Limited Warranty or applicable Service Labor Contract, the foregoing is exclusive and in lieu of all other warranties, whether written or oral, express or implied. This Warranty supersedes and excludes any prior oral or written representations or warranties. Delfield expressly disclaims any implied warranties of merchantability, fitness for a particular purpose or compliance with any law, treaty, rule or regulation relating to the Motor-Compressor, and the full liability of Delfield for any breach of this warranty, will be as provided in this warranty.

Other than any applicable Delfield Standard One year Limited Warranty, this Delfield Additional Four Year Protection Plan and any applicable Delfield Service Labor Contract, the Original Purchaser agrees and acknowledges that no other warranties are offered or provided in connection with or for the Motor-Compressor or any part thereof.

In no event will Delfield be liable for special, incidental or consequential damages, or for damages in the nature of penalties.



NOTES:

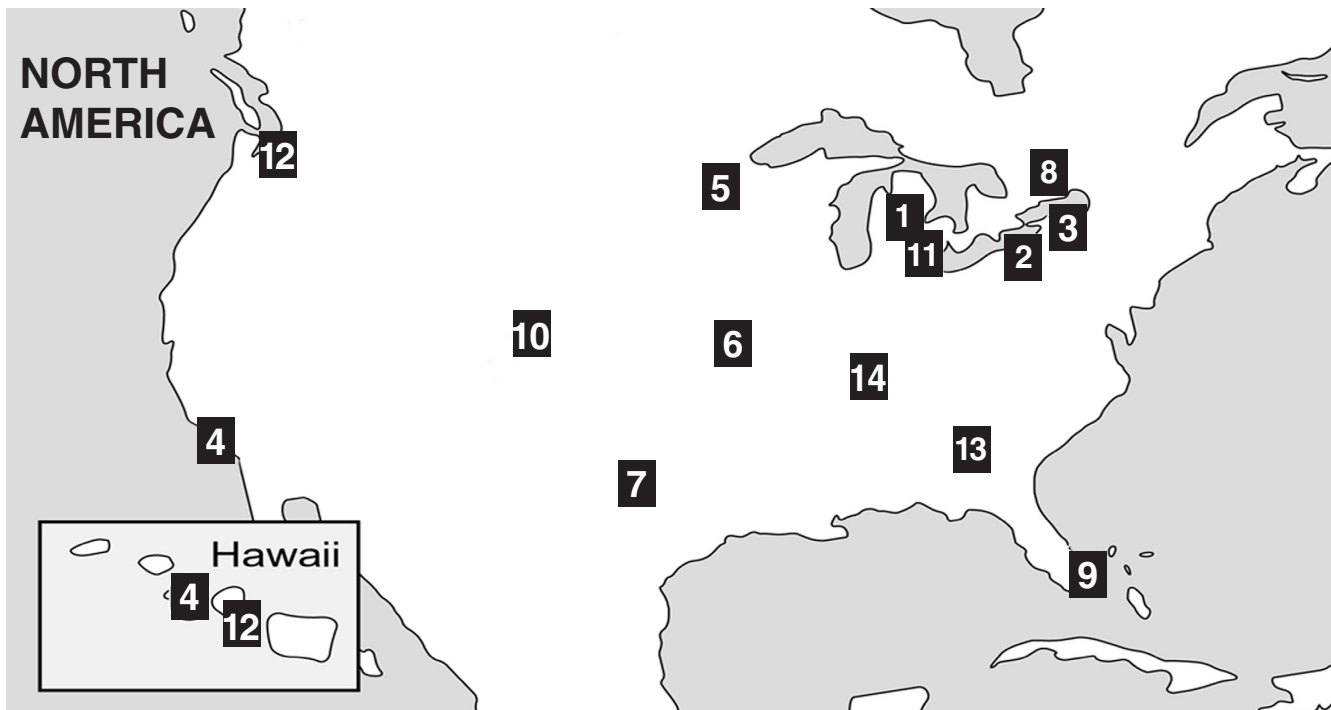

1) The Delfield Company
 980 South Isabella Road
 Mt. Pleasant, MI 48858
 800.733.8829
 989.773.7981
 989.773.3210 FAX
 custom parts direct from Delfield

2) A.I.S. Commercial Parts & Service
 1816 West 26th Street
 Erie, PA 16508-1149
 800.332.3732
 814.456.3732
 814.452.4843 FAX
 serves: MD, NJ, OH, PA, VA, WV

3) Appliance Installation Service
 1336 Main Street
 Buffalo, NY 14209
 800.722.1252
 716.884.7425
 716.884.0410 FAX
 serves: CT, DC, DE, MA, MD, ME, NH, NJ, NY, PA, RI, VA, VT, WV

4) Pacific Coast Parts
 15024 Staff Court
 Gardena, CA 90248
 1.800.531.1111
 1.800.782.5747
 Email: orders@pacparts.com
 www.pacparts.com
 serves: AZ, CA, HI, NV, OR

5) Contract Ice
 14450 Ewing Ave S. #100
 Burnsville, MN 55306
 800.422.2823
 952.894.4427
 952.894.2164 FAX
 serves: IA, MN, MT, ND, SD, WI

6) E.M.C.O. Sales & Distributors
 3909 St. Timothy Lane
 St. Ann, MO 63074
 800.972.7670
 314.427.7477
 314.427.8190 FAX
 serves: AR, IA, IL, KS, KY, MO, NE, OK, TX, NM, LA

7) Stove Parts Supply/GCS Service
 2120 Solona St.
 PO Box 14009
 Fort Worth, TX 76117-0009
 1.800.433.1804 toll free
 1.800.272.7358 fax
 serves: AR, LA, NM, OK, TX

8) Garland Group
 1177 Kamato Road
 Mississauga, Ontario L4W1X4
 800.427.6668
 800.361.7745 FAX
 serves: Canada

9) Global Parts and Supplies
 2920 N.W. 109th Avenue
 Miami, FL 33172
 305.994.9994
 305.994.9992 FAX
 International parts depot

10) Hawkins Commercial Appl. Serv.
 3000 S. Wyandot
 Englewood, CO 80110
 (800) 624-2117
 (303) 7618861 FAX
 serves: AZ, CO, KS, NE, NM, OK, UT, WY

11) MicroDine, Inc.
 44792 Helm
 Plymouth, MI 48170
 888.828.4454
 734.451.2043
 734.451.3215 FAX
 serves: MI, IN, WI, OH

12) Performance Refrigeration Parts
 9923 S.W. 178th St.
 Vashon, WA 98070
 888.872.2465
 206-463-1772
 206.463.4431 FAX
 serves: AK, HI, ID, MT, OR, WA

13) Southeastern Restaurant Services
 2200 Norcross Parkway, Suite 210
 Atlanta, GA 30071
 800.235.6516
 770.446.6177
 770.446.3157 FAX
 serves: FL, GA, MS, NC, SC, VA

14) T.M.A.
 2916 Sidco Drive
 Nashville, TN 37204
 615.726.0351
 800.737.0351
 615.259.4100 FAX
 serves: TN, AL

Delfield has 14 conveniently located Parts Depots to ensure parts are handled promptly and accurately.
 Delfield reserves the right to update or make changes to this list without prior notice
 Please call 1-800-733-8829 or check the web at www.delfield.com for a list of the current Parts Depots.



980 S. Isabella Rd., Mt. Pleasant, MI 48804-0470, U.S.A. • (989) 773-7981 or (800) 733-8821 • Fax (800) 669-0619 • www.delfield.com
 Delfield reserves the right to make changes in design or specifications without prior notice. 2003 The Delfield Company. All rights reserved. Printed in the U.S.A.