



Operators Manual

Installation, Operation & Service

Gas T1 Skillets

MODELS:

SGL-30-T1

SGL-40-T1



Enodis

1333 East 179th St., Cleveland, Ohio, U.S.A. 44110

Phone: (216) 481-4900 Fax: (216) 481-3782
Visit our web site at www.clevelandrange.com

SE95050

FOR THE USER

FOR YOUR SAFETY

DO NOT STORE OR USE GASOLINE OR ANY OTHER FLAMMABLE LIQUIDS AND VAPOURS IN THE VICINITY OF THIS OR ANY OTHER APPLIANCE.

WARNING: Improper installation, adjustment, alteration, service or maintenance can cause property damage, injury or death. Read the Installation, Operating & Service instructions thoroughly before installing or servicing this equipment.

IMPORTANT

POST IN A PROMINENT LOCATION, INSTRUCTIONS TO BE FOLLOWED IN THE EVENT THE USER SMELLS GAS. THIS INFORMATION SHALL BE OBTAINED BY CONSULTING YOUR LOCAL GAS SUPPLIER.

KEEP APPLIANCE AREA FREE AND CLEAR FROM COMBUSTIBLES.

DO NOT OBSTRUCT THE FLOW OF COMBUSTION AND VENTILATION AIR.

ALL SERVICE MUST BE PERFORMED BY A QUALIFIED CLEVELAND RANGE TECHNICIAN.

RETAIN THIS MANUAL FOR YOUR REFERENCE.

TABLE OF CONTENTS

Installation	<i>Inspection</i>	1
	<i>Shipping Damage Instructions</i>	1
	<i>General</i>	1
	<i>Clearance Requirements</i>	1
	<i>Installation</i>	1
	<i>Gas</i>	1
	<i>Electrical</i>	2
	<i>Ventilation</i>	2
	<i>Water Connection</i>	2
	<i>Installation Checks</i>	2
	<i>Cleaning</i>	2
	<i>Specification Drawing</i>	3
Operating Instructions	<i>General Parts Drawing</i>	4
	<i>Operating the Unit</i>	5
	<i>Operating Suggestions</i>	5
Cleaning Instructions	<i>Care & Cleaning</i>	6
Service Parts	<i>Warranty</i>	7
	<i>Faucet Assembly</i>	7
	<i>Frame Lid Assembly</i>	8
	<i>Component Plate Assembly - Power Tilt</i>	9
	<i>Gas Train, Trunion Assemblies</i>	10
	<i>Tilt Components</i>	11-12
	<i>Burner Assemblies</i>	13-15
	<i>Control Box Assembly</i>	16
	<i>Pilot Assembly</i>	17
	<i>Gas Ignition Control System</i>	17
	<i>2" Tangent Draw-Off Valve</i>	18
Maintenance	<i>Hinge Adjustment Instruction</i>	19
	<i>Lubrication Procedure</i>	19
	<i>Spare Parts Lists</i>	20
	<i>Sequence of Operations</i>	21
	<i>Power Tilt Manual Override</i>	21
	<i>Spare Parts List</i>	22
	<i>Wiring Diagram</i>	23
	<i>Symbols Library</i>	24-25

INSTALLATION

INSPECTION

Before unpacking visually inspect the unit for evidence of damage during shipping.

If damage is noticed, do not unpack the unit, follow shipping damage instructions.

SHIPPING DAMAGE INSTRUCTIONS

If shipping damage to the unit is discovered or suspected, observe the following guidelines in preparing a shipping damage claim.

1. Write down a description of the damage or the reason for suspecting damage as soon as it is discovered. This will help in filling out the claim forms later.
2. As soon as damage is discovered or suspected, notify the carrier that delivered the shipment.
3. Arrange for the carrier's representative to examine the damage.
4. Fill out all carrier claims forms and have the examining carrier sign and date each form.

GENERAL

Installation of the unit must be accomplished by qualified installation personnel working to all applicable local and national codes. Improper installation of product could cause injury or damage.

This equipment is built to comply with applicable standards for manufacturers. Included among those approval agencies are: UL, A.G.A., NSF, ASME/N.Bd., CSA, CGA, ETL, and others. Many local codes exist, and it is the responsibility of the owner/installer to comply with these codes.

Observe all clearance requirements to provide proper make-up air flow. Do not obstruct the flow of combustion and ventilation air. Check rating plate to ensure that unit has been equipped to operate with the type of gas available at the installation.

Dimensions and clearance specifications are shown on the specification sheet and in the Clearance Requirements section.

CLEARANCE REQUIREMENTS

FOR CLEARANCE REQUIREMENTS (TO COMBUSTIBLE AND NONCOMBUSTIBLE WALLS) AND ASSEMBLY DETAILS REFER TO SPECIFICATION DRAWING ON PAGE #3.

INSTALLATION

Note: For clearance requirements, suggested drain location and assembly details refer to "SPECIFICATION DRAWING" on page #3.

1. Position the unit in its permanent location, and level the unit by turning the adjustable feet.

2. Once positioned and leveled, permanently secure the unit's rear flanged feet to the floor using 5/16" lag bolts and floor anchors

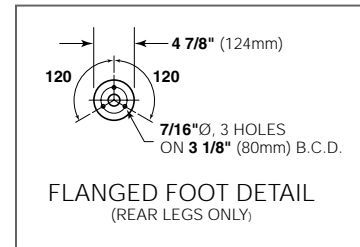

(supplied by the installer). Three bolts are required to secure each of the flanged feet.

3. Seal joints of flanged feet with a silicone sealant.

GAS

ENSURE THE GAS SUPPLY MATCHES THE UNIT'S REQUIREMENTS AS STATED ON THE RATING PLATE.

It is recommended that a sediment trap (drip leg) be installed in the gas supply line. If the gas pressure exceeds 14" water column, a pressure regulator must be installed, to provide a maximum of 14" water column gas pressure to the gas control valve.

Connect the gas line to the manual valve located at the rear of the control box.

Installation must be in accordance with local codes and/or the National Fuel Gas Code ANSI Z223.1 Latest Edition (USA) or the latest Installation Codes for Gas Burning Appliances and Equipment CAN/ CGA B149.1 (natural gas) and CAN/ CGA B149.2 (propane gas). Use a gas pipe joint compound which is resistant to L.P. gas. Test all pipe joints for leaks with soap and water solution. Ensure that the gas pressure regulator is set for the manifold pressure indicated on the gas rating plate.

The appliance and its individual shut-off valve must be disconnected from the gas supply piping system during any pressure testing of that system at test pressures in excess of 1/2 psi (3.45 kPa). The appliance must be isolated from the gas supply piping system by closing its individual manual shut-off valve during any pressure testing of the gas supply piping system at test pressures equal to or less than 1/2 psi (3.45 kPa).

ELECTRICAL

NOTE: Wiring diagram is located on the underside of the unit's control panel.

ENSURE THE ELECTRICAL SUPPLY MATCHES THE UNIT'S REQUIREMENTS AS STATED ON THE RATING LABEL.

A cord and plug are supplied with the 115 volt unit. Simply plug the unit into any grounded outlet rated for a minimum of 10 amps. The wiring diagram is located on the back of the console access panel.

When a unit is ordered and built for 208/240 volt, the supply line must be connected to the wiring terminations located inside the console. A wiring diagram is attached to the underside of the control panel.

WARNING: Electrical Grounding Instructions.

This unit is equipped with a three-prong (grounding) plug for your protection against shock hazard and should be plugged directly into a properly grounded three-prong receptacle. Do not cut or remove the grounding prong from this plug. Standard supply voltage is 115 volts A.C., however, optional A.C. voltages can be supplied on special order. A separate fused disconnect switch must be supplied and installed in the high voltage electrical supply line. The unit when installed, must be electrically installed and grounded in accordance with local codes, or in the absence of local codes, with National Electrical Code, ANSI/NFPA 70-1990 (USA) or the Canadian Electrical Code, CSA C22.2, Part 1 (Canada).

VENTILATION

Gas fired units are only to be installed under a ventilation hood in a room which has provisions for adequate make up air. Further information can be obtained by referring to the U.S.A. National Fire Protection Associations NFPA96 regulations. These standards have also been adopted by the National Building Code in Canada.

WATER CONNECTION

(OPTIONAL)

A 1/2" NPT cold water line and/or a 1/2" NPT hot water line are required if unit is equipped with a single or double pantry faucet.

INSTALLATION CHECKS

Although the unit has been thoroughly tested before leaving the factory, the installer is responsible for ensuring the proper operation of unit once installed.

DO NOT ATTEMPT TO OPERATE THIS UNIT DURING A POWER FAILURE.

KEEP APPLIANCE AND AREA FREE AND CLEAR OF COMBUSTIBLES.

1. Supply power to the unit by placing the fused disconnect switch to the "ON" position.
2. Turn on main gas supply to unit. Open the skillet's shut-off valve (located at lower rear left).
3. Toggle HI / OFF / LO Switch to the "HI" or "LO" position.
4. For your safety the skillet is equipped with a power interrupter which automatically shuts off the gas supply to the burners whenever the skillet is raised more than 8°.

IMPORTANT: Before commencing to cook, ensure the skillet pan is in the lowered position. Also ensure the cover is raised.

5. Turn temperature control to maximum. Tilt skillet pan until heat indicator light turns off and heating system shuts down. The pan should be on a 5-10° angle.
6. Lower pan. Heat indicator light will re-light and heating system will re-energize.
7. Unit will continue to heat, heat indicator light will remain on until temperature is reached. Then the heat indicator light will cycle OFF indicating the heating system has shut off. The heat indicator light will continue to cycle ON and OFF as the heating system cycles ON and OFF maintaining the desired temperature.
3. Toggle HI / OFF / LO Switch to the "OFF" position.

CLEANING

After installation the unit must be thoroughly cleaned and sanitized prior to cooking. See complete cleaning instructions in this manual (page #6).

SPECIFICATION DRAWING

DIMENSIONS

MODEL	A	B	C	D	E	E	F	G
					(combustible wall)	(non-combustible wall)		
SGL-30-T1	39 1/8" (994mm)	24 1/2" (623mm)	31 3/4" (807mm)	12" (305mm)	3 1/2" (89mm)	0	18 1/4" (464mm)	5 3/4" (146mm)
SGL-40-T1	51 1/8" (1299mm)	36 1/2" (928mm)	43 3/4" (1112mm)	18" (458mm)	3 1/2" (89mm)	0	24 1/4" (616mm)	5 3/4" (146mm)

SPECIFICATIONS

ELECTRICAL SUPPLY	GAS SUPPLY (PIPING 3/4" NPT)	CLEARANCE	APPROX. SHIPPING WEIGHTS
VOLTS: 120 PHASE: 1 AMPS: 10 FREQ: 60 HZ	TYPE: NAT or LP WATER COLUMN: 3.5 (NAT), 10 (LP) BTU PER CU. FT.: 1025 (NAT), 2500 (LP) SUPPLY PRESSURE: 5" W.C. MIN (NAT), 11" W.C. MIN (LP)	RIGHT: 3" (77mm) (manual tilt) 0 (power tilt) LEFT: 0" REAR: 0 (non-combustible wall) 3 1/2" (89mm) (combustible wall)	SGL-30-T 520 LBS. 235 KG. SGL-40-T 560 LBS. 255 KG
APPROVALS AGA <input checked="" type="checkbox"/> CGA <input checked="" type="checkbox"/> NSF <input checked="" type="checkbox"/>	BTU RATINGS: SGL-30-T: 125,000 per hour SGL-40-T: 200,000 per hour		

CAPACITIES

In 4 oz. servings. Other sizes may be calculated.
 30 gallons / 115 Liters.....960
 40 gallons / 150 Liters.....1280

NOTES

- Many local codes exist and it is the responsibility of the owner and installer to comply with the codes.
- Cleveland Range equipment is built to comply with applicable standards for manufacturers. Included among those approval agencies are U.L., NSF, CGA, CSA, ETL and others.

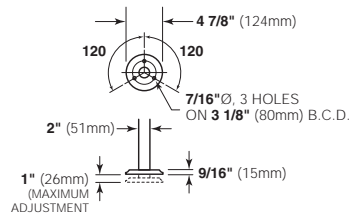
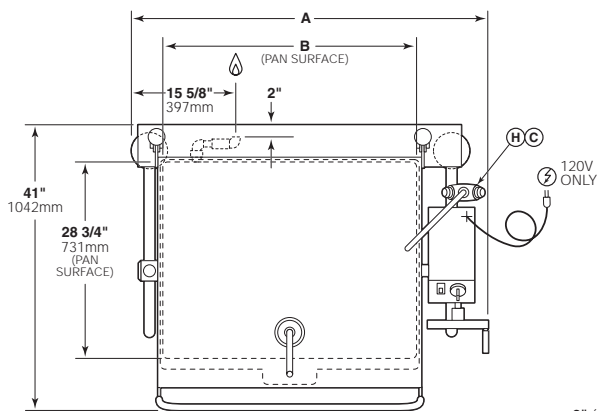

FLANGED FOOT DETAIL
(REAR LEGS ONLY)

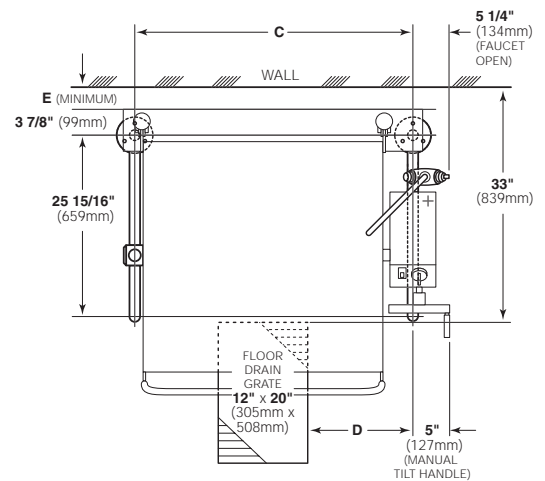
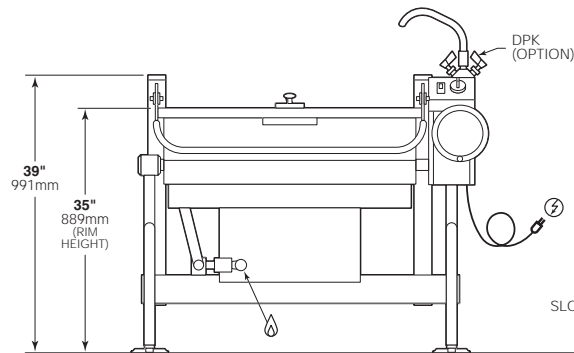

LEG LOCATION & SUGGESTED FLOOR DRAIN DETAIL

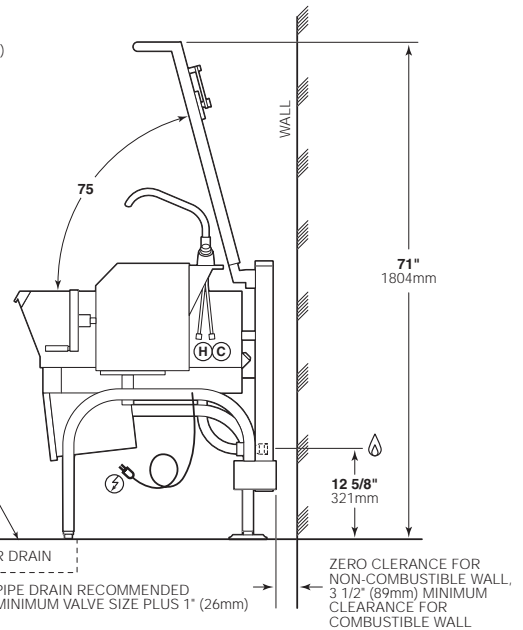

RECOMMENDED FLOOR SLOPE 1" (26mm) IN 4" (1220mm)

4" (102mm) MINIMUM
6" (153mm) RECOMMENDED

FLOOR DRAIN
PIPE DRAIN RECOMMENDED
MINIMUM VALVE SIZE PLUS 1" (26mm)

ZERO CLERANCE FOR NON-COMBUSTIBLE WALL
3 1/2" (89mm) MINIMUM CLEARANCE FOR COMBUSTIBLE WALL

OPERATING INSTRUCTIONS

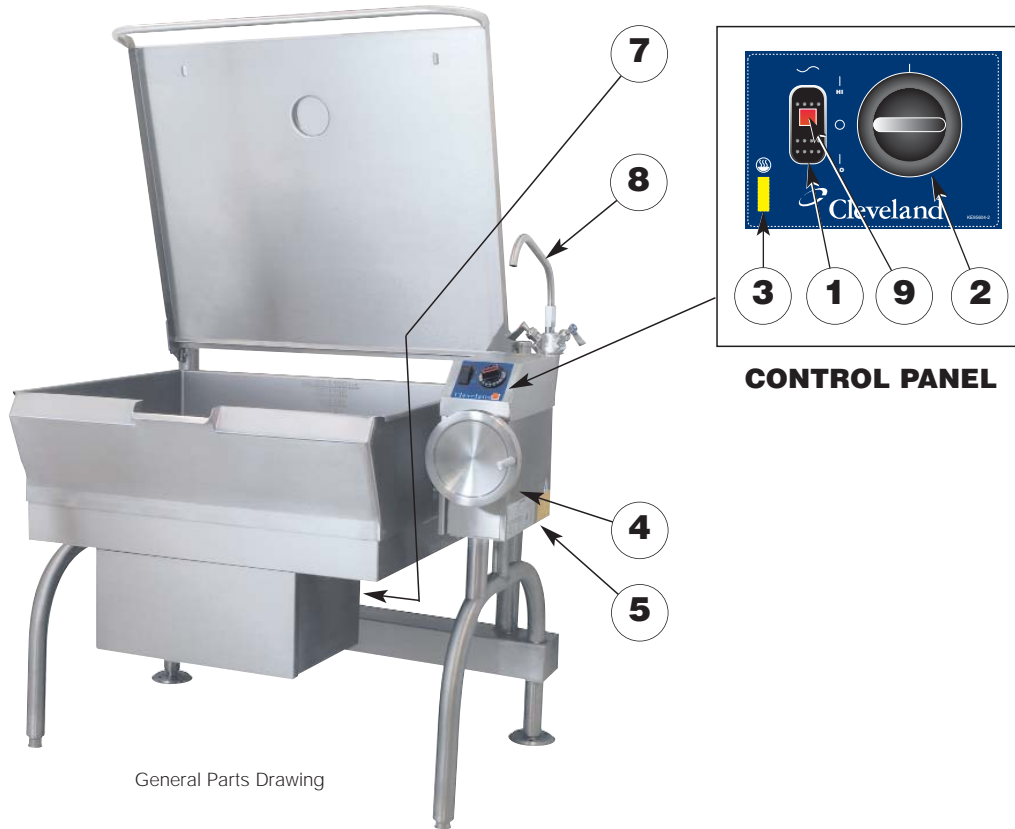

ITEM #	DESCRIPTION	FUNCTION
1.	HI / OFF / LO Switch	Center position - power to the unit is OFF. HI position - unit is in high fire mode (unit heats faster). LO position - unit is in low fire mode (unit heats slower).
2.	Temperature Dial	Regulates the surface temperature of the pan.
3.	Heat Indicator Light (Yellow)	Turns ON when system is calling for heat and OFF when system is satisfied.
4.	Hand Tilt Wheel	Used for tilting the pan up or down. Some units have an optional Power Tilt with the tilt switch located in the same position.
5.	Manual Tilt Override	Used on units with optional Power Tilt for tilting the pan up or down in case of power or mechanical failure.
6.	Tangent Draw-Off Valve (not shown)	Option - allows you to discharge product from the pan through the valve.
7.	Gas Shut Off Valve	Allows you to shut the gas off to the appliance if required.
8.	Faucet	Option - hot and/or cold faucet mounts to skillet for convenient filling of the pan.
9.	Power Indicator Light (Red)	Indicates power is on.

OPERATING THE UNIT

1. Ensure the gas and electrical supply to the unit are in the ON position.

FOR YOUR SAFETY:

This skillet will automatically shut off the gas supply when pan is raised more than 8°.

Before commencing to cook, ensure pan is in the lowered position.

2. **MANUAL TILT (4):** Cleveland skillets are equipped with a manual tilt mechanism for raising and lowering the pan. To raise pan, raise the cover and turn the crank clockwise. To lower pan, turn counterclockwise.

POWER TILT: Cleveland skillets can also be equipped with an optional electric power tilt mechanism for raising and lowering the pan. To raise pan, raise the cover and press up on the tilt switch. To lower pan, press down on the tilt switch.

3. Toggle HI / OFF / LO Switch (1) to the "HI" or "LO" position. The red Power Indicator Light (9) indicates power is on. The yellow Heat Indicator Light (3) indicates burners are on.
4. To preheat, set Temperature Dial (2) to desired cooking temperature. Unit is preheated when the yellow light goes out.
6. Insert product in pan.
7. If desired, once product has cooked, it can be held prior to serving at a lower temperature setting.
8. When cooking is completed, set Temperature Dial (2) and HI / OFF / LO Switch (1) to the OFF position.
9. The best time to clean the skillet is immediately after use, once skillet has cooled down. Refer to section titled "CLEANING INSTRUCTIONS" on page #6.

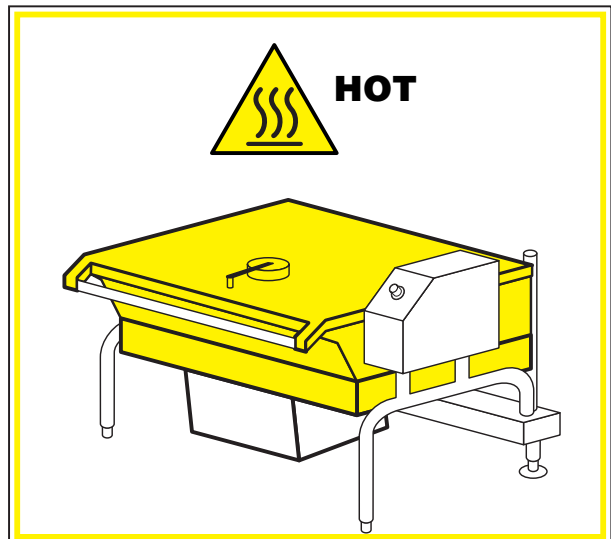
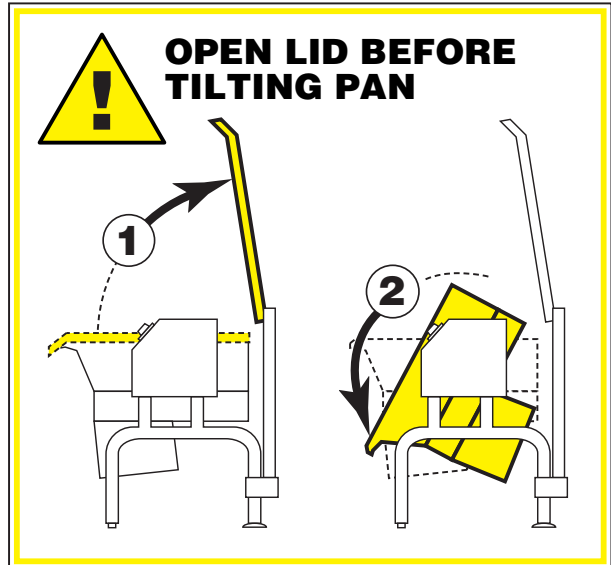

OPERATING SUGGESTIONS

1. Turn power switch to the "OFF" position when skillet is not in use.
2. Allow skillet to preheat before adding product.
3. Always lift the spring assist cover before activating the tilt mechanism.
4. During an electrical power interruption, turn Power Switch (1) to the OFF position. This unit cannot be made to operate without electrical power.

CLEANING INSTRUCTIONS



NOTE:

The best time to clean the skillet is immediately after each use, as soon as possible after cooking.

CARE AND CLEANING

Your skillet must be cleaned regularly to maintain its fast, efficient cooking performance, and to ensure its continued safe, reliable operation.



Chloride Cleaners

WARNING: Do not use chloride base detergents. There is a growing number of non-chloride cleaners available. If unsure of the cleaners chlorine content consult the supplier. Also avoid cleaners containing quaternary salt as they can cause the stainless steel to pit and rust.



Wire Brush & Scrapers

WARNING: Do not use a metal bristle brush or scraper, as this may permanently damage the skillet's stainless steel surface.



Steel Pads

WARNING: Steel wool should never be used for cleaning the cooking chamber of the skillet. Particles of steel wool become embedded in the cooking surface and rust, which may corrode the stainless steel.

NOTE: Unit should not be cleaned with a water jet.

NOTE: For more difficult cleaning applications one of the following can be used: alcohol, baking soda, vinegar, or a solution of ammonia in water.

NOTE: Never rub stainless steel in a circular motion, always rub in the direction of the polishing lines.

NOTE: Tomato and vinegar based products have a high acid content which could attack the skillet's stainless steel finish. After cooking with such products clean skillet interior with a solution of one tablespoon baking soda per one gallon of water.

1. Place the skillet's HI / OFF / LO Switch (1) to the OFF position.
2. Prepare a warm water and mild detergent solution in the skillet pan.

3. Remove food soil inside the skillet pan using a nylon brush.
4. Loosen food which is stuck to the skillet by allowing it to soak at a low temperature setting.
5. If the skillet is equipped with a draw-off valve, it should be cleaned as follows:
 - a) Remove food strainer from the skillet. Thoroughly wash and rinse the screen either in a sink or a dishwasher, then replace it into the skillet.
 - b) Disassemble the draw-off valve first by turning the valve knob counter-clockwise, then turning the large hex nut counter-clockwise until the valve stem is free of the valve body.
 - c) In a sink, wash and rinse the inside of the valve body using a nylon brush.
 - d) Reassemble the draw-off valve by reversing the procedure for disassembly. The valve's hex nut should be hand tight only.
6. Rinse skillet pan interior thoroughly, then drain the rinse water. Do not leave water sitting in unit when not in use.
7. Using mild soapy water and a damp sponge, wash the exterior of the skillet, rinse, and thoroughly dry.
8. Leave the cover off when the skillet is not in use.

RECOMMENDED CLEANERS FOR SPECIFIC SITUATIONS

Job	Cleaning Agent	Comments
Routine Cleaning	Soap, Ammonia Detergent, Medallion	Apply with cloth or sponge
Fingerprints & Smears	Arcal 20, Lac-O-Nu Ecoshine	Provides barrier film
Stubborn Stains & Discolouration	Cameo, Talc, Zud First Impression	Rub in direction of polish lines
Grease & Fatty Acids, Blood, Burnt-On Foods	Easy-Off, De-Grease It Oven Aid	Excellent removal on all finishes
Grease & Oil	Any good commercial detergent	Apply with sponge or cloth
Restoration/ Passivation	Benefit, Super Sheen	

SERVICE PARTS

WARRANTY

Our Company supports a worldwide network of Maintenance and Repair Centers. Contact your nearest Maintenance and Repair Centre for replacement parts, service, or information regarding the proper maintenance and repair of your cooking equipment

In order to preserve the various agency safety certification (UL, NSF, ASME/Ntl. Bd., etc.), only factory-supplied replacement parts should be used. The use of other than factory supplied replacement parts will void warranty.

FAUCET ASSEMBLY

ITEM NO.	PART NO.	DESCRIPTION	QTY.
1.	KE50825-7	3/4" SPOUT	1
2.	FA95022	RETAINING RING	1
3.	FA05002-19	"O" RING	1
4.	KE51736	LONG FAUCET NUT	1
5.	SE50020	HOT WATER STEM ASSEMBLY (DOUBLE PANTRY ONLY)	1
6.	SE50021	COLD WATER STEM ASSEMBLY	1
7.	KE51401	SINGLE PANTRY BODY (C/W ITEM NO. 6)	1
8.	KE50335	ADAPTER WASHER (SINGLE PANTRY ONLY)	1
9.	KE51403	DOUBLE PANTRY BODY (C/W ITEM NO. 5&6)	1
10.	SK00395-1	FAUCET MOUNTING BRACKET	1
11.	FA11258	HEX CAP SCREW	2
12.	FA30505-1	WASHER	2
13.	FA21008	HEX NUT	2
14.	SE50447	WASHER HORSESHOE	1

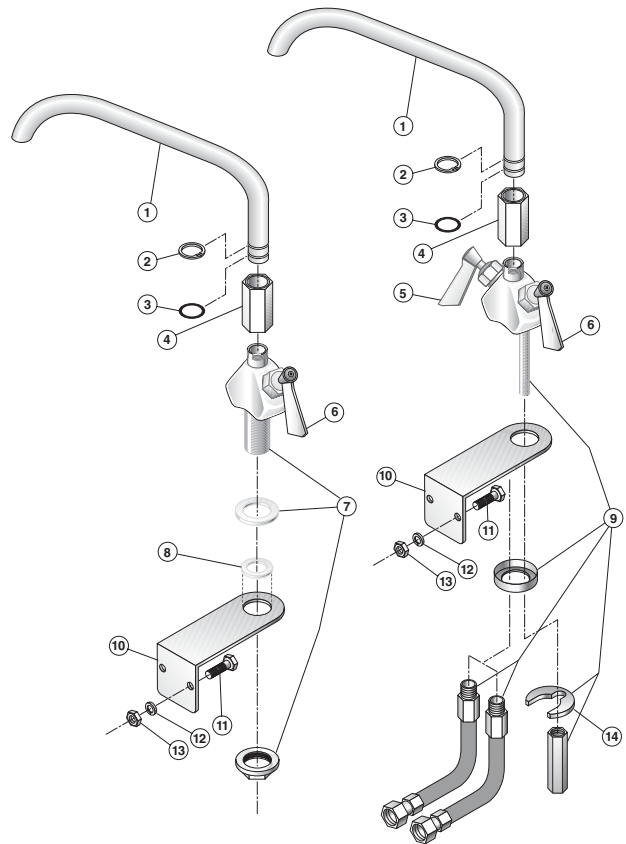

FRAME / LID ASSEMBLY

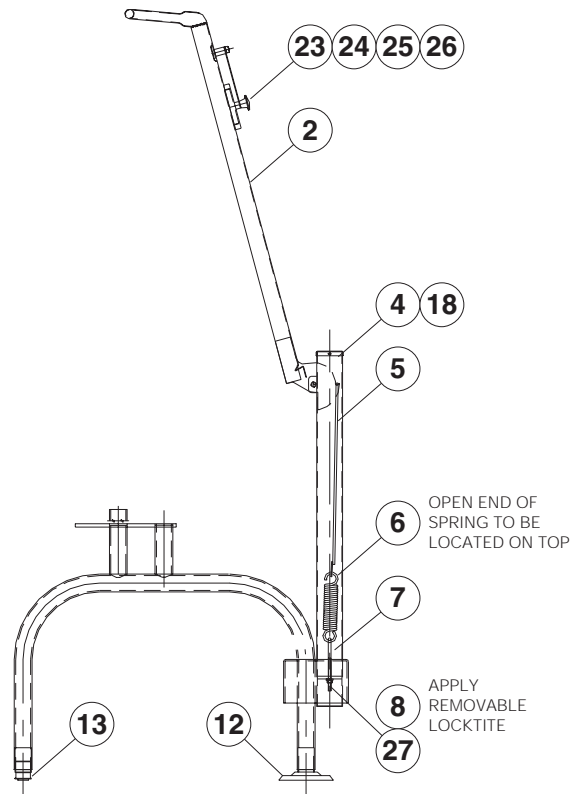
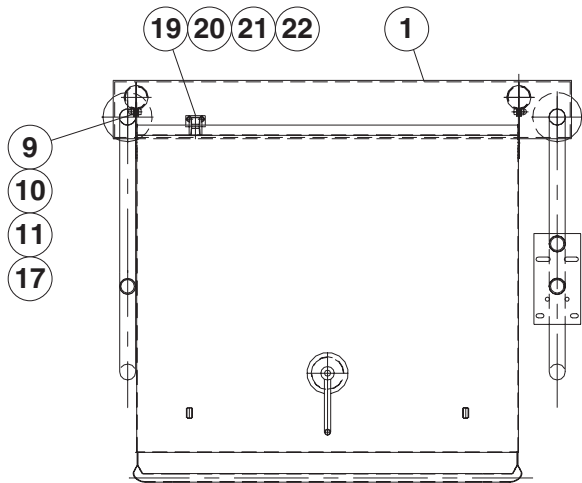

ITEM NO.	PART NO.	DESCRIPTION	QTY.
1.	SK00392-1	FRAME WELDMENT (30 GALLON)	.1
	SK00392-2	FRAME WELDMENT (40 GALLON)	.1
2.	SK2457192	LID ASSEMBLY (30 GALLON)	.1
	SK2457193	LID ASSEMBLY (40 GALLON)	.1
4.	KE50187-1	CAP	.2
5.	SK00394-1	HOOK WELDMENT	.2
6.	SK2452300	SPRING	.2
7.	FA95087-1	EYE BOLT	.2
8.	FA20008	HEX NUT	.2
9.	KE53573-1	BEARING	.2
10.	FA15019-4	SHOULDER BOLT	.2
11.	FA21501-2	ACORN NUT	.2
12.	KE00099	ADJUSTABLE FOOT (FLANGED)	.2
13.	KE50249-1	FOOT ADJUSTOR (W/O FLANGE)	.2
17.	FA31029	LOCKWASHER	.2
18.	FA11054	SCREW	.4
19.	SK2459299	COUPLING ASSEMBLY	.1
20.	FA21024	HEX NUT (5/16-18)	.2
21.	FA31030	LOCKWASHER	.2
22.	FA30055	FLAT WASHER	.2
23.	SK00054	VENT COVER ASSEMBLY	.1
24.	SK2211200	SPACER	.1
25.	FA95081-1	BOLT, MODIFIED	.1
26.	SK50179	WASHER	.1
27.	FA30504	WASHER	.2

COMPONENT PLATE ASSEMBLY - POWER TILT

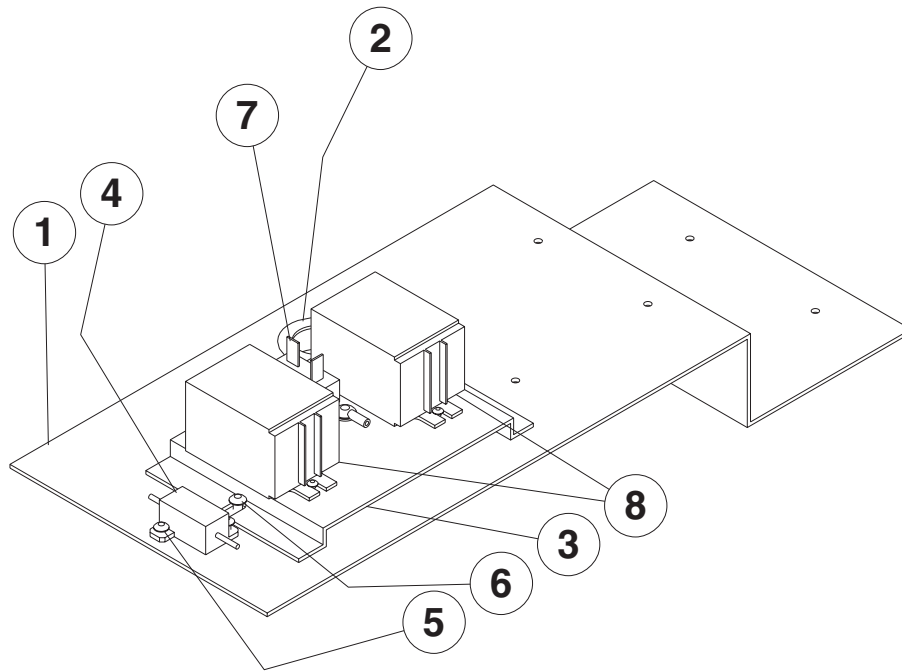

ITEM NO.	PART NO.	DESCRIPTION	QTY.
1.	SK00411	COMPONENT PLATE WELDMENT	1
2.	KE54833-4	SNAP-IN BUSHING	1
3.	KE02185-1	COMPONENT PLATE	1
4.	SK50930	RESISTOR	1
5.	F903	4 X 3/8 PAN PHIL.	2
6.	FA11504	10-24 X 3/8	2
7.	KE50581	BRIDGE RECTIFIER	1
8.	KE50753-10	RELAY	2

GAS TRAIN, TRUNNION ASSEMBLIES

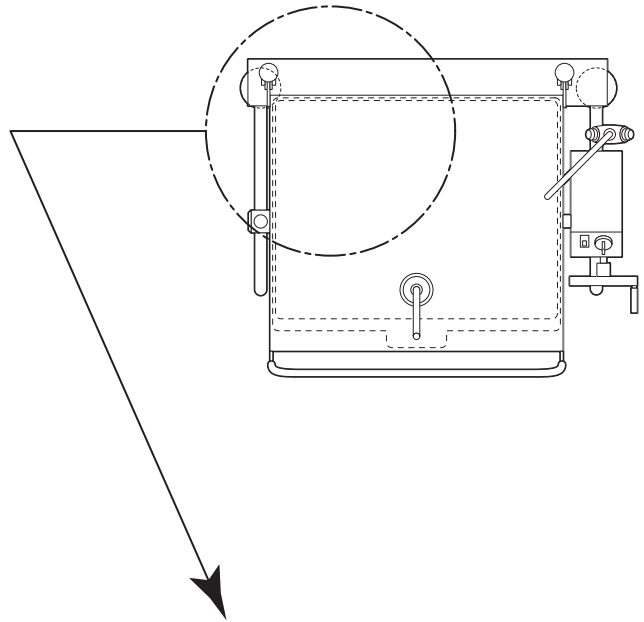

ITEM NO.	PART NO.	DESCRIPTION	QTY.
GAS TRAIN			
1.	FI00134	ELBOW	2
2.	F01518-1	SHUT OFF VALVE	1
3.	FI00607	NIPPLE	1
4.	SK2472702	SWIVEL CONNECTOR	1
5.	SK2472701	GAS CONNECTOR HOSE	1
TRUNNION			
6.	FA95027	BOLT MODIFIED	3
7.	KE00351	TRUNNION HOUSING ASSEMBLY ..	1
8.	KE50666	SPHERICAL WASHER	1
9.	FA95007-1	RETAINING RING	1

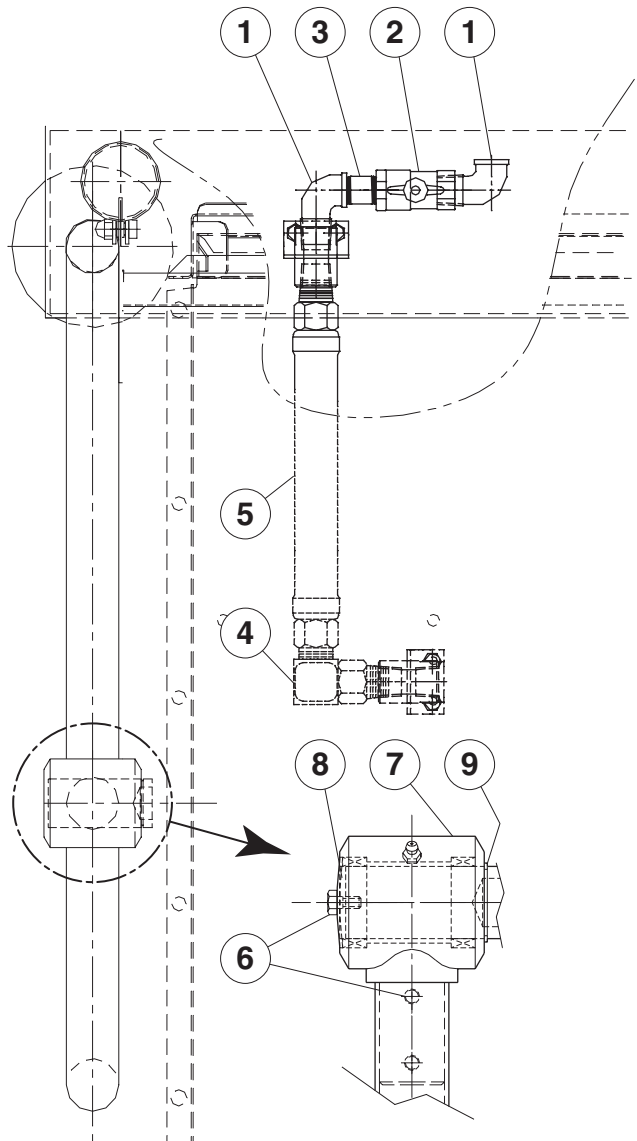

TILT COMPONENTS

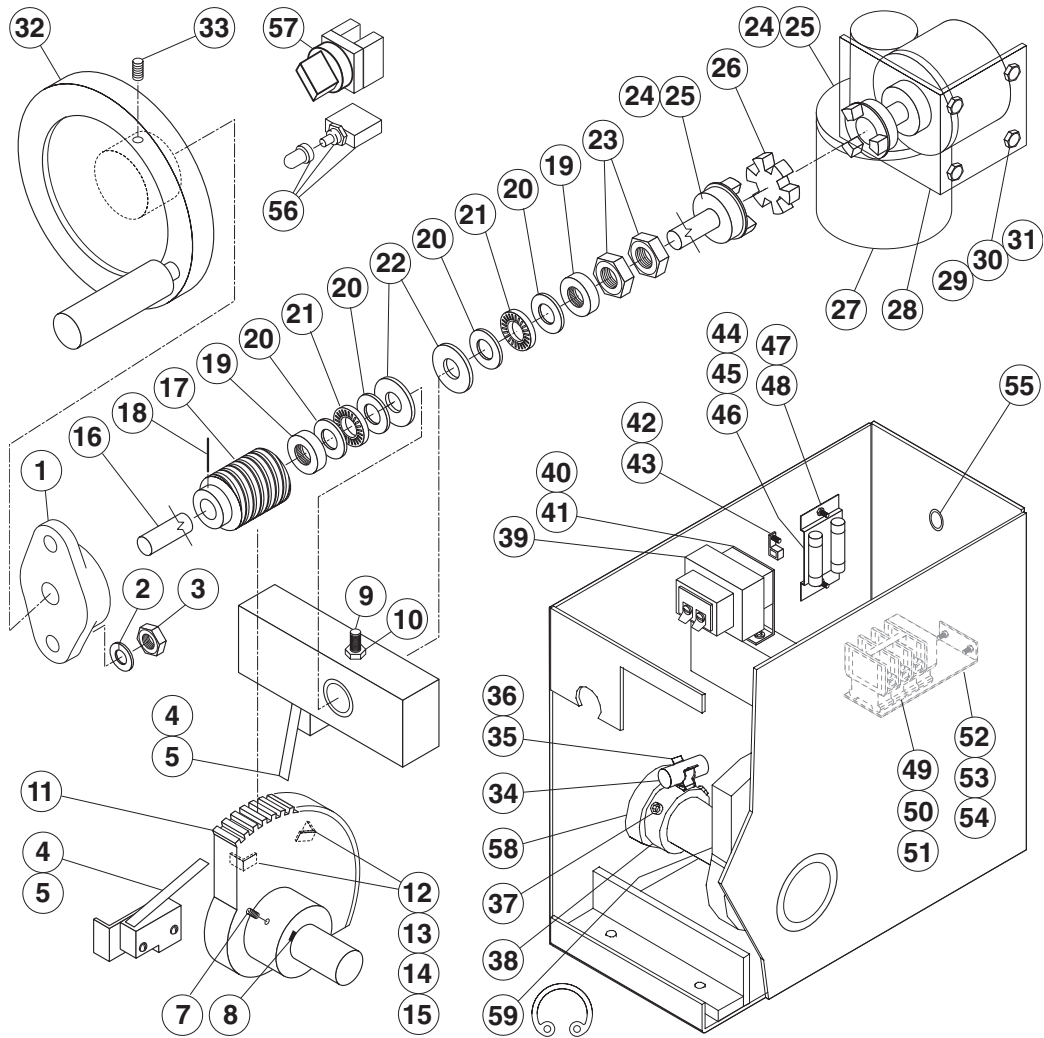

ITEM NO.	PART NO.	DESCRIPTION	QTY.
1.	KE51730	TILT SHAFT BEARING	1
2.	FA31010	LOCK WASHER, 3/8	2
3.	FA20030	HEX NUT, 3/8-16	2
4.	KE51007	LIMIT SWITCH, (POWER TILT)	2
5.	FA10140	SCREW, 6-32 X 1 1/4, (POWER TILT)	4
7.	FA19201	SET SCREW, 3/8-24 X 1/2	1
8.	FA95048	WOODRUFF KEY	1
9.	FA19177	HEX SOCKET SET SCREW, 5/16-24 X 1	1
10.	FA20047	JAM NUT, 5/16-24	1
11.	KE00151	SEGMENT GEAR, (MANUAL TILT)	1
	KE00279	SEGMENT GEAR, (POWER TILT)	1
12.	KE50312	LIMIT SWITCH TURN OFF BRACKET, (POWER TILT)	2
13.	FA11258	HEX SCREW, 1/4-20 X 3/4, (POWER TILT)	4
14.	FA31029	SPLIT LOCKWASHER, (POWER TILT)	4
15.	FA30505-1	WASHER, 1/4, (POWER TILT)	4
16.	KE50441	SHAFT, (POWER TILT)	1
	KE50375	SHAFT, (MANUAL TILT)	1

TILT COMPONENTS (continued)

17.	KE50315	WORM	1
18.	FA95005	TENSION PIN	1
19.	KE52193	THRUST BEARING SPACER	2
20.	KE52192	THRUST WASHER	4
21.	KE52191	ROLLER BEARING	2
22.	FA19500-2	WASHER, 1 1/2 X 13/16 X 1/8	2
23.	FA95008	JAM NUTS	2
24.	KE50582	1/2 COUPLING WITH 5/8 BORE, (POWER TILT)	2
25.	FA95014	SET SCREW 1/4-2 X 3/8, (POWER TILT)	1
26.	KE50583	COUPLING INSERT, (POWER TILT)	1
27.	KE52832-4	DC MOTOR, (POWER TILT)	1
28.	KE54829-4	BRACKET FOR MOTOR, (POWER TILT)	1
29.	FA11258	HEX SCREW, 1/4-20 X 3/4, (POWER TILT)	7
30.	FA30505-1	WASHER, 1/4, (POWER TILT)	7
31.	FA21008	HEX NUT, 1/4 - 20, (POWER TILT)	7
32.	KE00508	HANDWHEEL ASSEMBLY, (MANUAL TILT)	1
33.	FA19186	SET SCREW, HANDWHEEL, (MANUAL TILT)	1
34.	KE50294-1	MERCURY SWITCH	1
35.	KE50295-1	CLIP	1
36.	FA15018-1	MACHINE SCREW	1
37.	FA19184	3/8-16 X 3/8 SET SCREW	1
38.	SK50047-1	TRUNNION COLLAR	1
39.	KE53838-25	TRANSFORMER	1
40.	KE53444	BRACKET	1
41.	FA11091	SCREW, 8-32 X 3/8	2
42.	KE50473	GROUND LUG	1
43.	F900	K-LOCK NUT, 1/4-20	1
44.	KE52936-8	FUSE, 1.25 AMP	1
45.	KE52936-6	FUSE, 3 AMP	1
46.	KE51139	FUSE HOLDER	2
47.	SK50945-1	BRACKET	1
48.	F900	K-LOCK NUT, 1/4-20	1
49.	KE50377	TERMINAL BLOCK	3
50.	KE50376	TERMINAL BLOCK END	1
51.	FA11091	SCREW, 8-32 X 3/8	2
52.	KE50374	TERMINAL BLOCK BRACKET	1
53.	FA21008	HEX NUT, 1/4 - 20	2
54.	FA30505-1	WASHER, 1/4	2
55.	KE54833-1	SNAP-IN BUSHING	1
56.	KE50579-1	CIRCUIT BREAKER	1
	FA05002-34	"O" RING, CIRCUIT BREAKER	1
	KE50580	WATER RESISTANT BOOT	1
57.	KE53137-3	MERCURY SWITCH	1
	KE53184	CONTACT SECTION HOLDER (LATCH)	1
	KE53138-1	CONTACT BLOCK	4
58.	KE51711	BEARING, NEEDLE	2
59.	FA95007-1	RETAINING RING	1

BURNER ASSEMBLY

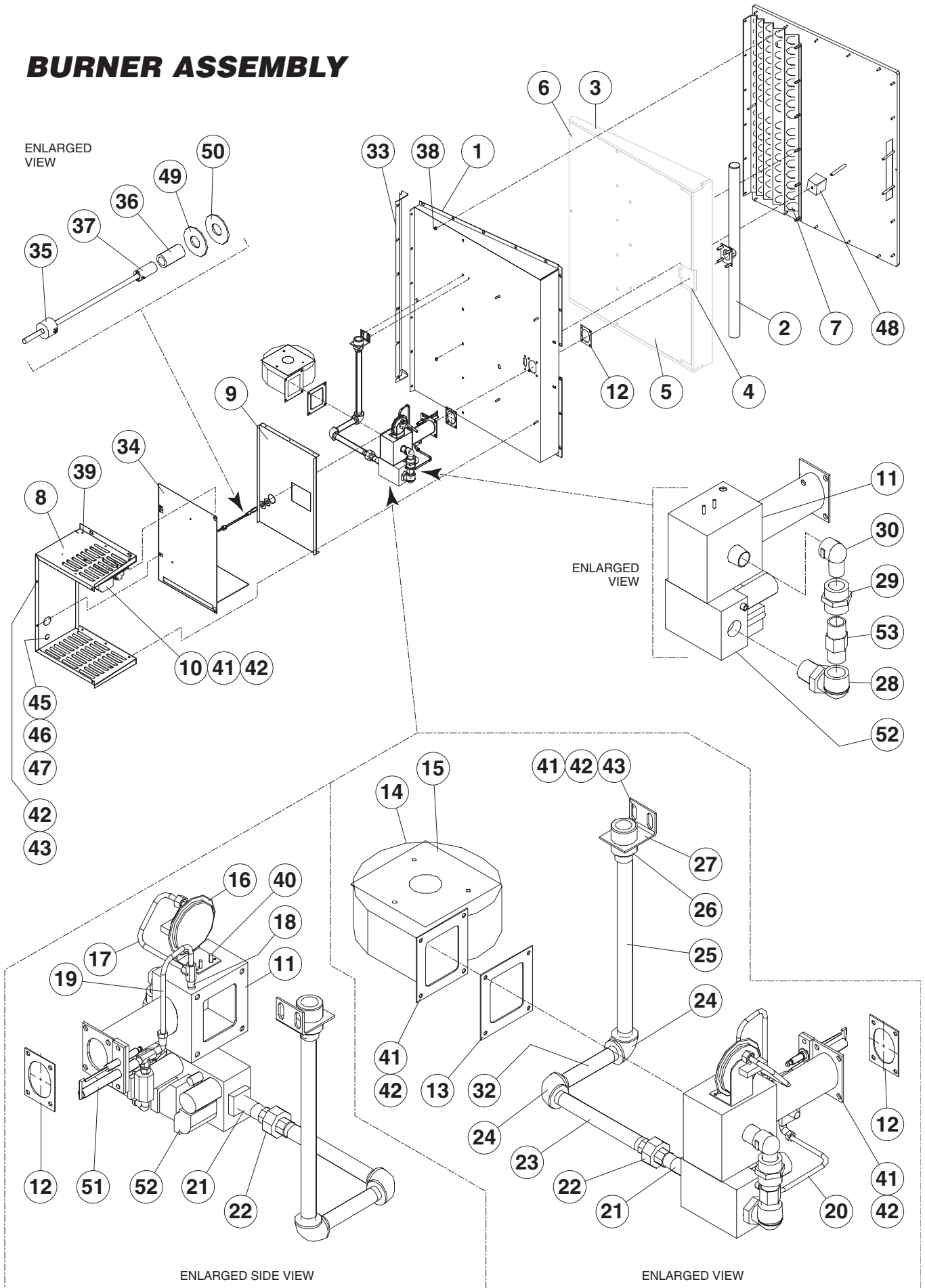

BURNER ASSEMBLY

ITEM NO.	PART NO.	DESCRIPTION	QTY.
1.	SK00399-1	BURNER PAN ASSEMBLY (30 GALLON)	1
	SK00389-1	BURNER PAN ASSEMBLY (40 GALLON)	1
2.	SK2495500	BURNER ASSEMBLY (30 GALLON)	1
	SK2478800	BURNER ASSEMBLY (40 GALLON)	1
3.	SK2460300	INSULATION, SIDE	2
4.	SK2460700	INSULATION, BURNER/IGNITOR	1
5.	SK2460500	INSULATION FRONT (30 GALLON)	1
	SK2460400	INSULATION FRONT (40 GALLON)	1
6.	SK50939-1	INSULATION BOTTOM (30 GALLON)	1
	SK50919-1	INSULATION BOTTOM (40 GALLON)	1
7.	SK2494999	BAFFLE ASSEMBLY (30 GALLON)	1
	SK2471099	BAFFLE ASSEMBLY (40 GALLON)	1
8.	SK00396-1	BOX ASSEMBLY	1
9.	SK2471200	HEAT SHIELD (30 GALLON)	1
	SK50927-1	HEAT SHIELD (40 GALLON)	1
10.*	SK00397-1	GAS IGNITION CONTROL ASSEMBLY.	1
	<i>* SEE "GAS IGNITION CONTROL SYSTEM" DRAWING FOR MORE DETAIL</i>		
11.	SK2463299	AIR MIX CHAMBER ASSEMBLY	1
12.	SK2460000	GASKET, BURNER MOUNTING	2
13.	SK2460200	GASKET, FAN MOUNTING	1
14.	SK2476000	BLOWER FAN	1
15.	SK2480101	AIR ORIFICE: BLOWER (30 GALLON)	1
	SK2480100	AIR ORIFICE: BLOWER (40 GALLON)	1
16.	SK2488100	AIR SWITCH	1
17.	SK2491100	1/4 TUBE AIR PROVE	1
18.	SK2473000	COMPRESSION TEE	1
19.	SK2491200	1/4 TUBE AIR MIX - IGNITOR	1
20.	SK2491300	1/4 TUBE GAS VALVE ELBOW COMPT.	1
21.	FI05226-1	NIPPLE	1
22.	FI00073-1	UNION	1
23.	FI05226-7	NIPPLE	1
24.	FI00040-1	ELBOW	2
25.	SK01477-11	NIPPLE (30 GALLON)	1
	SK01477-12	NIPPLE (40 GALLON)	1
26.	FI05231	REDUCER	1
27.	SK2459299	COUPLING ASSEMBLY	1
28.	SK076015-2	ELBOW, 3/4 UNION	1
29.	SK076029-70	UNION	1
30.	SK2489700	STREET ELBOW	1
32.	FI05226-8	NIPPLE	1
33.	SK2495200	INNER FLUE (30 GALLON)	1
	SK2463100	INNER FLUE (40 GALLON)	1
34.	SK2462899	COVER ASSEMBLY, GAS COMPT. BOX	1
35.	SK50933-1	SENSOR	1
36.	SK2490600	FULL COUPLING, S.S.	1

BURNER ASSEMBLY (continued)

37.	SK2487800	BAYONET, ADAPTER1
38.	F95	PAL NUT15-19
39.	F10	SCREW, PAN QUARD, 8-32X3/86
40.	F900	K-LOCK NUT, 10-243
41.	FA21008	HEX NUT, 1/4 -20 S.S.23-25
42.	FA31029	SPLIT LOCKWASHER, 1/4-S.S.23-25
43.	FA11258	HEX SCREW, 1/4-20 X 3/48-10
44.	FA30505-1	WASHER, 1/413-15
45.	SK50399	CONNECTOR, 1/2 LIQUIDTIGHT1
46.	KE54617-1	CONNECTOR, 45 DEG. 1/2 TIGHT1
47.	KE51916-2	1/2 LIQUIDTIGHT1
48.	SK50941-1	PROBE INSULATION (30 GALLON)1
	SK50941-2	PROBE INSULATION (40 GALLON)1
49.	FA30505-3	WASHER1
50.	SK2460900	GASKET1
51.*	SK00398-1	PILOT ASSEMBLY, NATURAL GAS1
	SK00398-2	PILOT ASSEMBLY, LP1
	* SEE "PILOT ASSEMBLY" DRAWING FOR MORE DETAIL		
52.	SK2488200	GAS VALVE, NATURAL GAS1
	SK2488201	GAS VALVE, LP1
53.	SK2499600	ORIFICE, NATURAL GAS (30 GALLON)1
	SK2473100	ORIFICE, NATURAL GAS (40 GALLON)1
	SK2499700	ORIFICE, LP. (30 GALLON)1
	SK2473200	ORIFICE, LP. (40 GALLON)1

CONTROL BOX ASSEMBLY

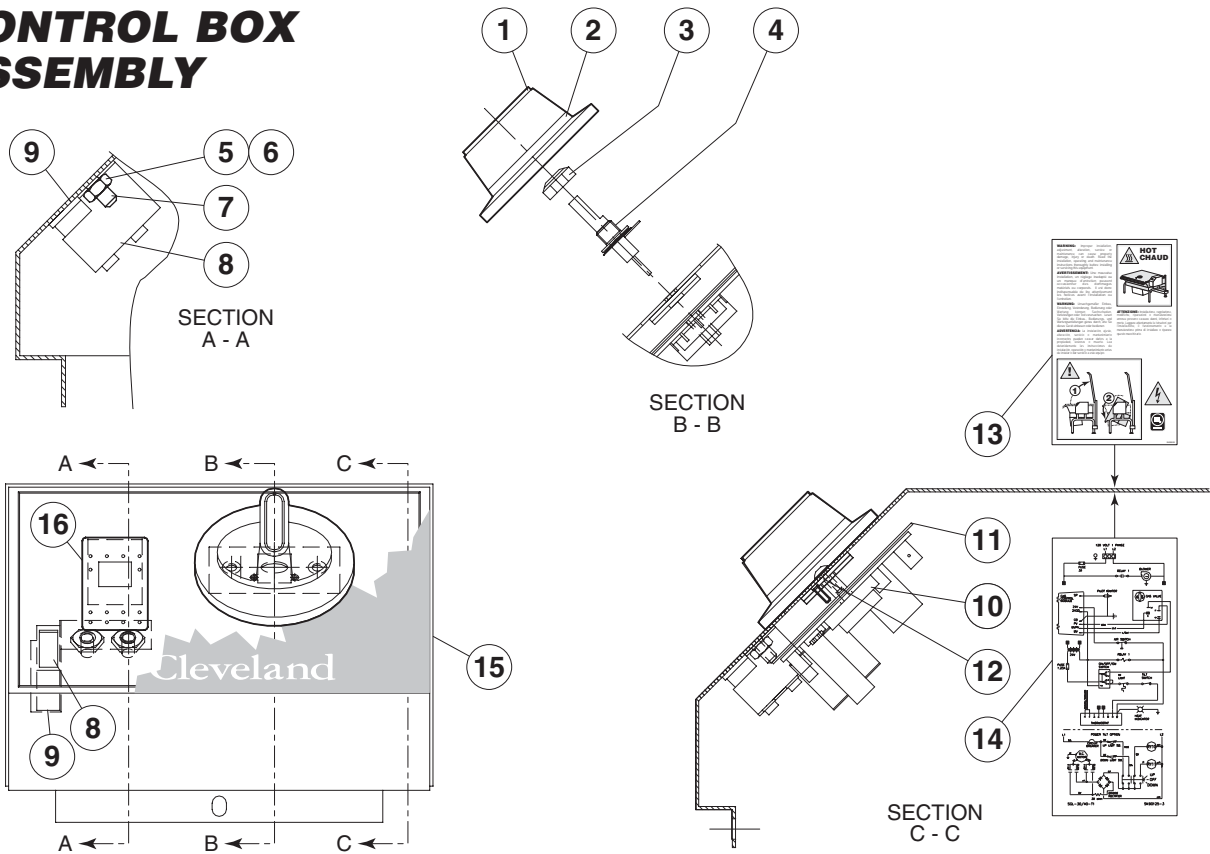

ITEM NO.	PART NO.	DESCRIPTION	QTY.
1.	SK2138700	KNOB ASSEMBLY	1
2.	SK2360700	DIAL INSERT °F	1
	SK2360701	DIAL INSERT °C	1
3.	KE51005	RUBBER BOOT. #N9030 X 1/4	1
4.	SK2498399	POTENTIOMETER SHAFT ASSEMBLY	1
	SK2166800	POTENTIOMETER SHAFT	1
	SK2167000	TENSION PIN	1
	SK2167100	WASHER, BOWED/SPRING	1
	SK2167200	RETAINING RING, SP-NR #R1000-25	1
	SK2167300	PANEL BEARING	1
	SK2382800	RETAINING RING CLIP	1
5.	FA21006	NUT, S.S. F#10-24	2
6.	FA32022	TOOTH LOCK WASHER #10 S.S.	2
7.	FA40000-6	#10-24 X 3/8 S.S. WELD STUD	2
8.	SK50903	BRACKET, INDICATOR LIGHT	1
9.	SK50905-1	HEAT INDICATOR, 28V	1
10.	SK2142002	THERMOSTAT	1
11.	SK2159300	THERMOSTAT INSULATOR	1
12.	SK2491500	STOP PLATE ASSEMBLY	1
13.	SK95063	CAUTION LABEL	1
14.	SK90125-2	WIRING DIAGRAM MANUAL TILT	1
	SK90125-3	WIRING DIAGRAM POWER TILT	1
15.	SK90125-2	CONTROLS LABEL	1
16.	SK2474102	SWITCH, ON/OFF/ON, DUAL FIRING	1

INCLUDES

PILOT ASSEMBLY

ITEM NO.	PART NO.	DESCRIPTION	QTY.
1.	SK00398-1	PILOT ASSEMBLY, NATURAL GAS	1
	SK00398-2	PILOT ASSEMBLY, LP	1
2.	SK2460100	GASKET	1
3.	SK2477000	IGNITOR/PILOT ASSEMBLY	1
4.	SK2488300	GAS REGULATOR	1
5.	SK2489800	TEE, 1/8	1
6.	FI05198-1	ELBOW, 1/8	2
7.	SK2488400	VARIABLE ORIFICE NATURAL GAS	1
	SK2488401	VARIABLE ORIFICE PROPANE	1

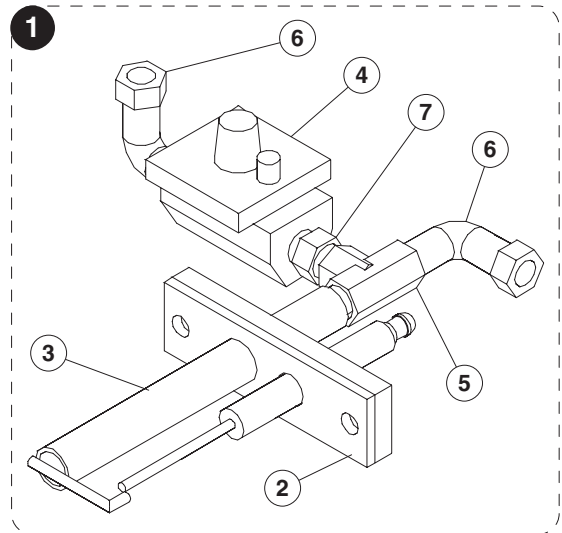

GAS IGNITION CONTROL SYSTEM

ITEM NO.	PART NO.	DESCRIPTION	QTY.
1.	SK00397-1	GAS IGNITION CONTROL ASSEMBLY	1
2.	SK2475300	GAS CONTROL MODULE	1
3.	SK50931	BRACKET FOR HIGH LIMIT	1
4.	KE55069-7	HIGH LIMIT	1
5.	FA12	SCREW, 10-24 X 3/8	8
6.	SK2475600	HOLDER	1
7.	SK2475500	RELAY	1
	SK2475700	SPRING	1

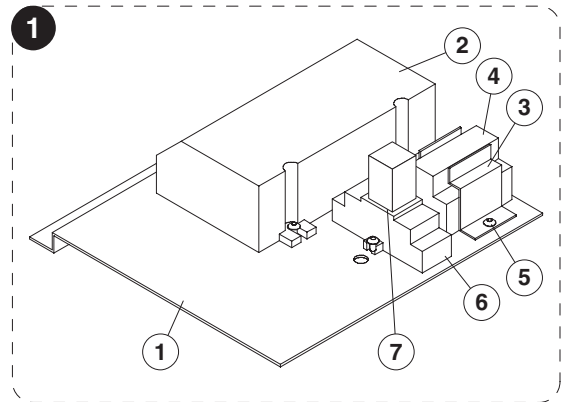

2" TANGENT DRAW-OFF VALVE

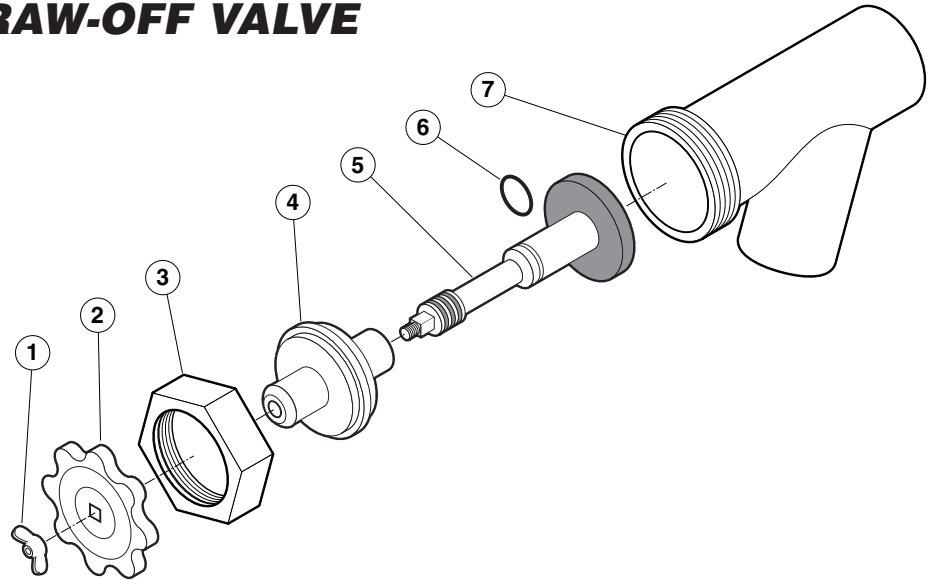

ITEM NO.	PART NO.	DESCRIPTION	QTY.
1. - 7.	KE50972-B	DRAW-OFF ASSEMBLY	1
1.	FA95049	WING NUT	1
2.	KE527551	KNOB	1
3.	KE52754	HEX NUT	1
4.	KE52753	RETAINER	1
5.	KE52752	PISTON	1
6.	FA00111	"O" RING	1
7.	KE52751	VALVE BODY	2

MAINTENANCE



WARNING:

Any maintenance or service involving disassembly of components should be made by a qualified service technician. Ensure gas, electrical and water supply (if applicable) to the unit are shut off.

HINGE ADJUSTMENT INSTRUCTIONS

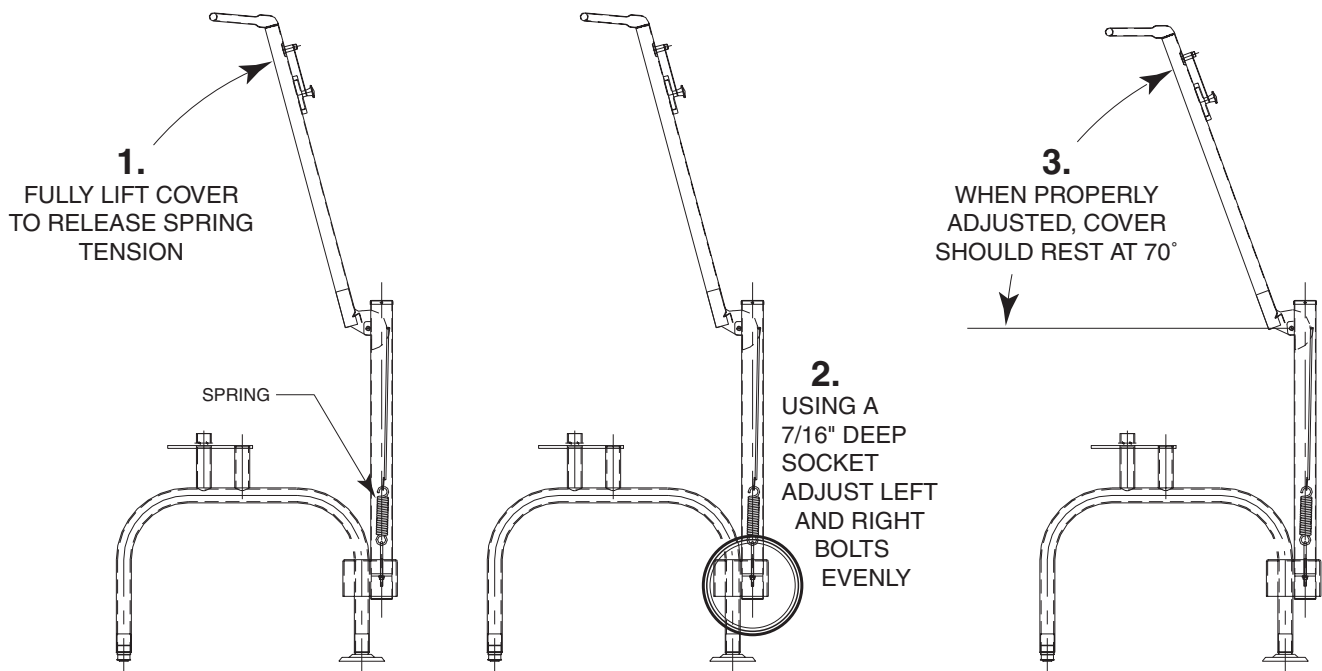

LUBRICATION PROCEDURE

Lubricate the following parts every three months to insure smooth operation and reduce wear.

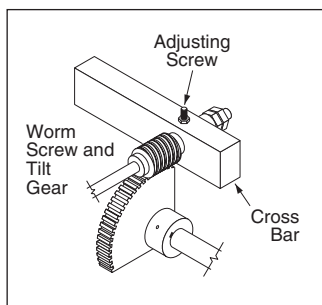

TRUNNION HOUSING, WORM SCREW AND TILT GEAR

These parts are accessed through the top cover of the console.

Apply grease to gear teeth. Check for

excessive play and adjust with adjusting screw located on top of cross bar.

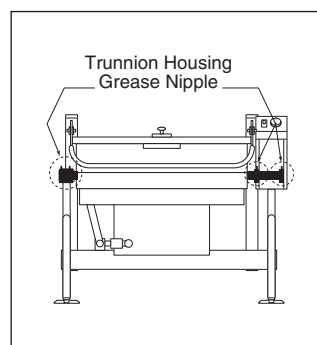

TRUNNIONS

On the left hand side of the skillet there are two grease nipples on the top back portion of the trunnion housing. On the right hand side of the kettle you must remove the console cover to access the two grease nipples.

BURNER ASSEMBLY GASKET EXAMINATION PROCEDURE

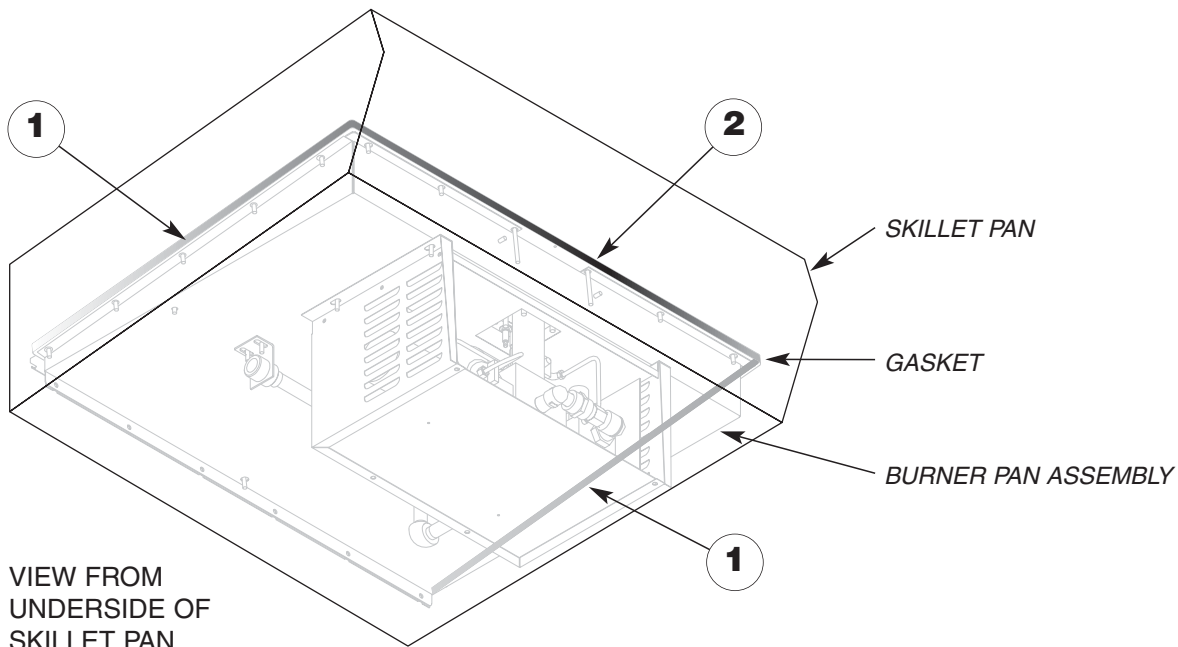

NOTE: It is imperative that this procedure be completed at least twice yearly.

1. Turn skillet to ON. The burner must be firing during this procedure.
2. Using a stainless steel extension mirror, inspect gasket between burner pan assembly and skillet pan (sides and front only).
3. Replace gasket if:
 - gasket shows signs of deterioration
 - a flame can be seen coming through the gasket
 - condensation forms on the extension mirror (indicating escaping heat)

GASKET PART #s

		30 GALLON	40 GALLON
1	SIDES	SK2472402	SK2472402
2	FRONT	SK2472400	SK2472401

SEQUENCE OF OPERATIONS

When using these instructions refer to the SGL-TI wiring schematic.

- 115 VAC is sent through the 3 amp fuse to
 - The primary of the 24 VAC transformer
 - 24 VAC is sent from the secondary of the 24VAC transformer to the Hi/Off/Low Switch.
 - Contacts of the RI Blower Relay
 - The optional Power Tilt Circuit
- With the Hi/Off/Low switch in the Low position.
 - 24 VAC is sent through the normally closed high limit switch to the mercury switch.
 - If the skillet is in the down position then 24 VAC is sent through mercury switch to pin 9 on the thermostat.
- With the Hi/Off/Low Switch in the Hi position 24 VAC is also sent to the Hi terminal on the gas valve.
 - Gas will not leave the valve until the main gas valve opens (see step 7).
- If the steamer is calling for heat the 24 VAC is sent from pin number 10 to R1 Blower Relay.
 - The normally open contacts of the blower relay close sending 115 VAC to the blower.
 - The blower turns closing the air switch.
 - 24 VAC is sent through the now closed air switch to the ignition module.
- Ignition module sends spark from terminal SP to the igniter.
- Ignition module also sends 24 VAC from pins PV and MV/PV to the pilot coil of the gas valve pins P and C.
 - Pilot valve opens sending gas to the Pilot assembly.
 - Spark and gas meet and pilot is ignited.
 - AC current is passed through the flame and rectified then sent back to the ignition module.
- If the ignition module reads a minimum of 1.0 micro-amps through the burner ground then 24 VAC is sent from pins MV and MV/PV of the ignition module to pins M and C on the Gas valve.
 - The main (low) gas valve opens and gas (3.0" W.C. natural gas or 8.0" W.C. LP) is sent to the burner.
 - If the skillet is in the Hi position (see step 3) 24VAC will be at the HI terminal and the gas pressure will be (3.5" W.C. natural or 10.0" W.C. LP.
 - Burner ignites until thermostat is satisfied.
- When thermostat is satisfied, 24 VAC is removed from pin 10 on the thermostat and the heat circuit is de-energized
- If the skillet has the optional Power Tilt option and is in the down position, 115 VAC is sent from the customer connect through the circuit breaker and the up limit switch to the tilt switch.
- With the tilt switch in switch in the Up position
 - 115 VAC is sent to the Bridge Rectifier
 - 115 VDC is sent from the rectifier through the 30-ohm resistor to the normally open RY10 and RY11 relay contacts.
 - 115 VAC is sent to the RY 10 relay coil.
 - The normally open RY10 contact close and 90 VDC is sent to the DC motor
 - The DC motor is energized and the skillet tilts until the switch is released or the up limit switch opens.
- With the Tilt switch in the Down position
 - 115 VAC is sent to the Bridge Rectifier
 - 115 DC is sent from the rectifier through the 30-ohm resistor to the normally open RY10 and RY11 relay contacts.
 - 115 VAC is sent to the RY 11 relay coil.
 - The normally open RY 11 contact close and the polarity of the 90 VDC is reversed.
 - The DC motor is energized and the skillet lowers until the switch is released or the Down limit switch opens.

POWER TILT MANUAL OVERRIDE

In case of power failure or malfunction the skillet pan can be tilted manually following these instructions.

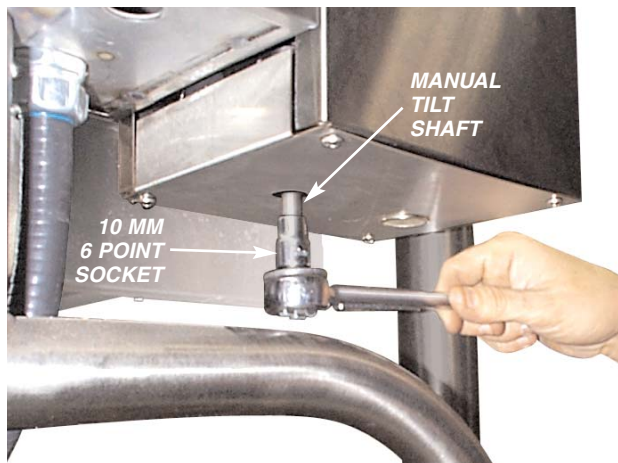

1. Fit a 10 MM 6 POINT SOCKET over the MANUAL TILT SHAFT as shown above.
2. Turn socket wrench clockwise to empty contents.

SPARE PARTS LIST

PART NO.	DESCRIPTION	QTY.
KE50294-1	MERCURY SWITCH	1
KE53838-25	TRANSFORMER	1
KE52936-8	FUSE, 1.25 AMP	1
KE52936-6	FUSE, 3 AMP	1
SK00397-1	GAS IGNITION CONTROL ASSEMBLY	1
SK50933-1	OPERATING THERMOSTAT	1
SK24882000	GAS VALVE, NATURAL GAS	1
SK2488201	GAS VALVE, LP	1
SK2498399	POTENTIOMETER SHAFT ASSEMBLY	1
	<i>INCLUDES:</i>	
SK2166800	<i>POTENTIOMETER SHAFT</i>	1
SK2167000	<i>TENSION PIN</i>	1
SK2167100	<i>WASHER, BOWED/SPRING</i>	1
SK2167200	<i>RETAINING RING, SP-NR #R1000-25</i>	1
SK2167300	<i>PANEL BEARING</i>	1
SK2382800	<i>RETAINING RING CLIP</i>	1
SK50905-1	INDICATOR LIGHT CLEAR, 28V	1
SK2142002	THERMOSTAT	1
SK2477000	IGNITOR/PILOT ASSEMBLY	1
SK2488300	GAS REGULATOR	1
SK2475300	GAS CONTROL MODULE	1
KE55069-7	SAFETY THERMOSTAT	1
SK2475500	RELAY	1
SK2474102	SWITCH, ON/OFF/ON, DUAL FIRING	1

WIRING DIAGRAM

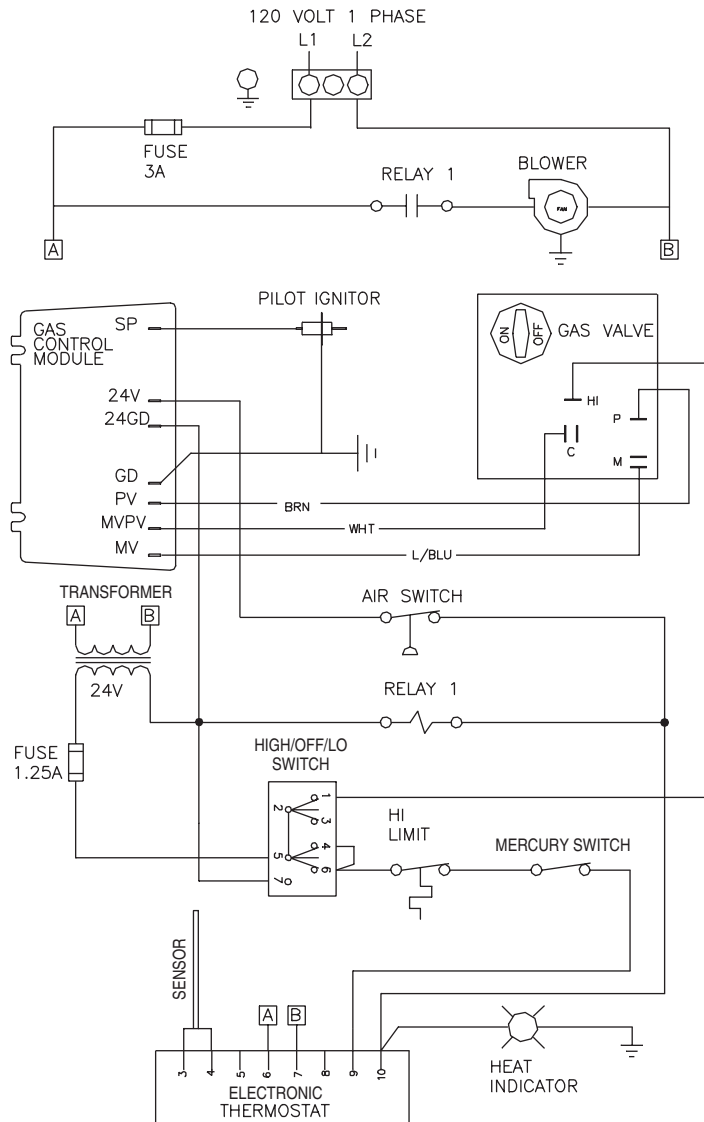

ELECTRICAL COMPONENT PART #s

SEE PAGE #

FUSE 3A	KE52936-6	12
FUSE 1.25A	KE52936-8	12
RELAY 1	SK2475500	17
BLOWER	SK2476000	14
PILOT IGNITOR	SK2477000	17
GAS CONTROL MODULE	SK2475300	17
GAS VALVE (NATURAL)	SK2488200	15
GAS VALVE (LP)	SK2488201	15
TRANSFORMER, 24V	KE53838-25	12
AIR SWITCH	SK2488100	14
HIGH/OFF/LO SWITCH	SK2474102	16
HIGH LIMIT	KE55069-7	17
MERCURY SWITCH	KE50294-1	12
THERMOSTAT	SK2142002	16
SENSOR	SK50933-1	14
HEAT INDICATOR	SK50905-1	16
CIRCUIT BREAKER	KE50579-1	12
LIMIT SWITCH	KE51007	11
RY10 (RELAY)	KE50753-10	9
RY11 (RELAY)	KE50753-10	9
DC MOTOR	KE52832-4	12
BRIDGE RECTIFIER	KE50581	9
RESISTOR	SK50930	9
MERCURY SWITCH	KE53137-3	11
- SECTION	KE53184	11
- CONTACT BLOCK	KE53138-1	11

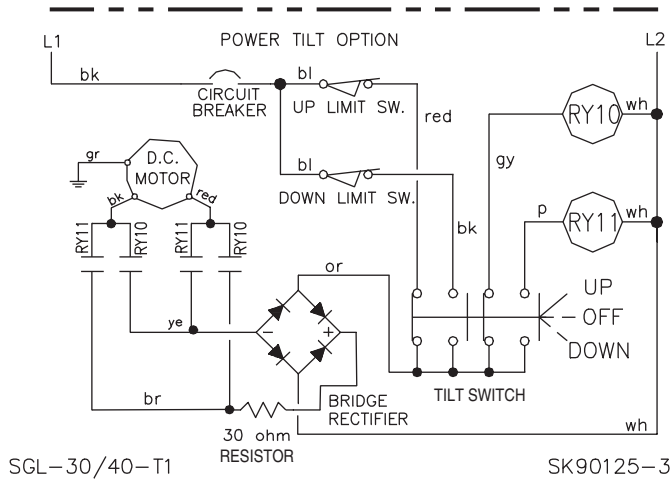

SGL-30/40-T1

SK90125-3

Symbol Legend (page 1 of 2)

□ English □ French □ Spanish □ Italian □ German □ Chinese-Simplified □ Chinese-Traditional

	<p>RISK OF ELECTRICAL SHOCK DANGER DE SECOUSSE ÉLECTRIQUE PELIGRO DE ELECTROCHOQUE PERICOLO DI SCOSSA STROMSCHLAG-GEFAHR</p> <p>有触电危險 有觸電危險</p>	
	<p>SPLASHPROOF ANTIÉCLABOUSSURES A PRUEBA DE SALPICADURAS PROTETTO CONTRO GLI SPRUZZI SPRITZWASSERDICHT</p> <p>防濺水的 防濺水的</p>	
	<p>DISCONNECT ELECTRICAL SUPPLY BEFORE WORKING ON KETTLE COUPER LE COURANT AVANT D'INTERVENIR SUR L'ÉQUIPEMENT DESCONECTAR LA ALIMENTACION ELECTRICA ANTES DE REALIZAR TRABAJOS EN EL EQUIPO DISINSERIRE LA CORRENTE PRIMA DI LAVORARE SULLA MACCHINA STROMVERSORGUNG AUSSCHALTEN, BEVOR AM GERÄT GEARBEITET WIRD</p> <p>操作设备前切断电源 操作設備前切斷電源</p>	
	<p>MAIN POWER ALIMENTATION ÉLECTRIQUE ALIMENTACION PRINCIPAL ALIMENTAZIONE HAUPTSTROM</p> <p>主电源 主電源</p>	 <p>ON MARCHE ENCENDIDO ACCESO AN</p> <p>开 開</p>
	<p>OFF ARRÊT APAGADO SPENTO AUS</p> <p>关 關</p>	 <p>PAUSE, INTERRUPTION PAUSE, INTERRUPTION PAUSA, INTERRUPCION PAUSA, INTERRUZIONE PAUSE, UNTERBRECHUNG</p> <p>暫停，间断 暫停，間斷</p>
	<p>CONTINUE CONTINUER CONTINUAR CONTINUA WEITER</p> <p>继续 繼續</p>	 <p>RESET RÉENCLANCHER RECONECTAR RESET NULLSTELLEN</p> <p>重新设定 重新設定</p>
	<p>START OF ACTION DÉBUT DE L'ACTION INICIAR FUNCIONAMIENTO INIZIO OPERAZIONE FUNKTION STARTEN</p> <p>开始操作 開始操作</p>	 <p>STOP OF ACTION ARRÊT DE L'ACTION PARAR FUNCIONAMIENTO ARRESTO OPERAZIONE FUNKTION STOPPEN</p> <p>停止操作 停止操作</p>
	<p>FAST START DÉMARRAGE RAPIDE INICIO RAPIDO AVVIAMENTO RAPIDO SCHNELLER START</p> <p>快启动 快啓動</p>	 <p>FAST STOP, EMERGENCY ARRÊT RAPIDE D'URGENCE PARADA RAPIDA, EMERGENCIA ARRESTO RAPIDO, EMERGENZA SCHNELLER STOPP, NOTFALL</p> <p>快止动，紧急 快止動，緊急</p>

Symbol Legend (page 2 of 2)

☐ English ☐ French ☐ Spanish ☐ Italian ☐ German ☐ Chinese-Simplified ☐ Chinese-Traditional



AUTOMATIC TEMPERATURE CONTROL
COMMANDE AUTOMATIQUE DE LA TEMPÉRATURE
AJUSTE AUTOMÁTICO DE TEMPERATURA
CONTROLLO AUTOMATICO TEMPERATURA
AUTOMATISCHE TEMPERATURREGELUNG

自动温度控制
自動溫度控制



LOW WATER
NIVEAU BAS DE L'EAU
NIVEL DE AGUA BAJO
LIVELLO BASSO
WASSERSTAND NIEDRIG

低水量
低水量



BURNER AND/OR ELEMENT ENERGIZED
BRÛLEUR ET/OU ÉLÉMENT ALLUMÉ
QUEMADOR O ELEMENTO ENCENDIDO
FIAMMA E/O ELEMENTO ATTIVATI
BRENNER ODER ELEMENT EINGESCHALTET

燃烧器和/或元件带电
燃燒器和/或元件帶電



IGNITION FAILURE
PANNE D'ALLUMAGE
FALLO DE ENCENDIDO
MANCATA ACCENSIONE
ZÜNDUNGSFEHLER

点火失效
點火失效



HEATING
ÉBULLITION
CALEFACCION
RISCALDAMENTO
HEIZUNG

加热
加熱



COOLING
REFROIDISSEMENT
REFRIGERACION
RAFFREDDAMENTO
KÜHLUNG

冷却
冷卻



HEAT ADJUSTMENT
RÉGLAGE DE LA CHALEUR
REGULACION DE CALOR
REGOLAZIONE RISCALDAMENTO
WÄRMEREGULIERUNG

热调节
熱調節



MIXER BRIDGE
PONT DU MÉLANGEUR
PUENTE DE MEZCLADORA
MENSOLA MESCOLATORE
MISCHER-BRÜCKE

搅拌桥
攪拌橋



LEFT KETTLE
BOUILLLOIRE GAUCHE
HERVIDOR IZQUIERDO
BOLLITORE SINISTRO
LINKER KOCHKESSEL

左壺
左壺



RIGHT KETTLE
BOUILLLOIRE DROITE
HERVIDOR DERECHO
BOLLITORE DESTRO
RECHTER KOCHKESSEL

右壺
右壺



MIX
MÉLANGER
MEZCLAR
MESCOLATURA
MISCHEN

混合
混合



LIFT
LEVER
LEVANTAR
SOLLEVARE
HEBEN

提升
提升



UP
HAUT
ARRIBA
SU
RAUF

向上
向上



DOWN
BAS
ABAJO
GIÙ
RUNTER

向下
向下



HOT WATER
EAU CHAUDE
AGUA CALIENTE
ACQUA CALDA
HEISSES WASSER

热水
熱水



COLD WATER
EAU FROIDE
AGUA FRIA
ACQUA FREDDA
KALTES WASSER

冷水
冷水