



# Operators Manual

Installation, Operation & Service

## Skillets

### TABLE TOP ELECTRIC SKILLETS-

MODELS:  
SET-10 SET-15



SET-15



SET-10



Enodis

1333 East 179th St., Cleveland, Ohio, U.S.A. 44110

Phone: (216) 481-4900 Fax: (216) 481-3782  
Visit our web site at [www.clevelandrange.com](http://www.clevelandrange.com)

**IMPORTANT**

THE INSTALLATION AND CONNECTION MUST COMPLY WITH  
THE LOCAL AND NATIONAL ELECTRICAL CODES

ENSURE ELECTRICAL SUPPLY CONFORMS WITH ELECTRICAL  
CHARACTERISTICS SHOWN ON THE RATING PLATE

**RETAIN THIS MANUAL FOR YOUR REFERENCE.**

# **INSTALLATION INSTRUCTIONS FOR TABLE TOP ELECTRIC SKILLETS**

## **INSPECTION**

Before unpacking visually inspect the unit for evidence of damage during shipping. If damage is noticed, do not unpack the unit, follow shipping damage instructions.

## **SHIPPING DAMAGE INSTRUCTIONS**

If shipping damage to the unit is discovered or suspected, observe the following guidelines in preparing a shipping damage claim.

1. Write down a description of the damage or the reason for suspecting damage as soon as it is discovered. This will help in filling out the claim forms later.
2. As soon as damage is discovered or suspected, notify the carrier that delivered the shipment.
3. Arrange for the carrier's representative to examine damage.
4. Fill out all carrier claims forms and have the examining carrier sign and date each form.

## **GENERAL INFORMATION**

These instructions must be retained by the owner/user for future reference.

The serial plate is located on the right side of the control housing. Voltage, phase, amperage and wattage are stated on the plate.

This equipment is built to comply with applicable standards for manufacturers. Included among those approval agencies are: UL, NSF, ASME/Ntl.Bd., CSA, ETL, and others. Many local codes exist, and it is the responsibility of the owner and installer to comply with these codes.

## **GENERAL INSTALLATION**

Check the electrical rating plate to ensure that the unit is correct voltage, amperage, phase and wattage.

Observe all clearance requirements to provide air supply for proper operation, as well as sufficient clearance for servicing. Keep the skillet area free and clear of combustibles. Dimensions and clearance specifications are shown on the specification sheet.

**WARNING:** Installation of skillet must be accomplished by qualified installation personnel, working to all applicable local and national codes. Improper installation of product could cause injury or damage, and void the warranty.

Installation must be in accordance with local codes and/or the National Electric Code ANSI/NFPA No. 70-latest edition (USA) or the Canadian Electrical Code CSA Standard C22.1 (Canada) and CAN/CGA-B149 codes for Gas Burning Equipment. The skillet must be electrically grounded by the installer.

Electrically powered skillets require a separate fused disconnect switch which must be supplied and installed in the high voltage electrical supply line. The wire gauge size and electric supply must match the power requirements specified on the skillet's rating plate. The conduit-enclosed permanent copper wiring must be adequate to carry the required current at rated voltage. Refer to the specification sheet for electrical specifications and location of electrical connections.

## INSTALLATION CLEARANCES

This unit must be installed in accordance with the following clearances in order to provide proper operation and servicing of the appliance. Also, it is recommended the unit be installed with sufficient clearances to provide proper cleaning and maintenance. **Minimum clearances are 1" (25mm) for the sides and back.**

## INSTALLATION

1. Carefully remove unit from carton or crate. Remove any packing material from unit. On stainless steel panels, the protective material should be removed before the unit is installed.
2. Set skillet in position where electrical services are nearby. Comply with clearances stated on the specification sheet. Ensure there is sufficient clearance between skillet and back wall.
3. Table-top models must be positioned on a firm, level stand or existing counter top, and bolted in place, using the four 5/16"-18 rods and nuts included with the skillet. These models are supplied with four 5/16"-18 weldnuts welded to underside of the base.

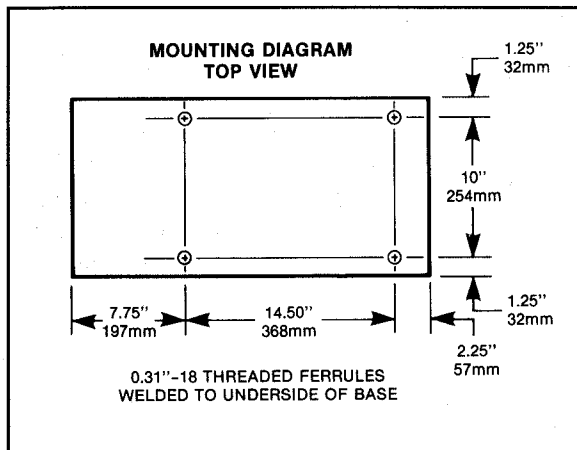

Make four 3/8" holes in an existing stand or countertop, in order to secure the base of the skillet. Once the holes are made, screw the threaded rods into the ferrules on the bottom of the skillet base. Then insert the threaded rods through the holes on the stand or countertop. Thread the nuts onto the threaded rod and tighten to secure base. Once secure and level, apply a seal of silicon, supplied with the skillet, to the entire edge of the base at the countertop. This will prevent food particles from entering underneath the skillet base. Screw the tilt handle into the threaded mounting block welded to the side of the skillet.

## ELECTRICAL CONNECTION

SET-10: Remove the screw at the rear of the console cover, and remove the cover. A wiring diagram is affixed to the underside of the cover. Feed conduit-enclosed permanent copper wiring through the cut-out in the rear of the console, and fasten to the three-connection terminal block. Be sure to connect the ground wire to the separate ground terminal connector (ground lug). Replace the console cover and secure it with the screw.

SET-15: Remove the two screws securing the console cover, and remove the cover. A wiring diagram is affixed to the underside of the cover. Feed conduit-enclosed permanent copper wiring through the cut-out in the rear of the console, and fasten to the pigtail leads fastened to the single contactor. Be sure to connect the ground wire to the separate ground terminal connector (ground lug). Replace the console cover and secure it with the screws.

## INSTALLATION CHECK

Although the skillet has been thoroughly tested before leaving the factory, the installer is responsible for ensuring the proper operation of the skillet once installed.

1. Ensure that electric supply to the skillet is turned on.
2. Remove the lift-off cover.
3. Place the skillet's power on/off switch to the "on" position.
4. Dial the thermostat switch to the maximum setting. The indicator light near the thermostat switch should be illuminated until the set temperature is reached, then cycle on and off as the thermostat cycles on and off to maintain the set temperature.
5. Pour 2 gallons (8 litres) of cool tap water into preheated skillet pan.
6. It should take approximately 3 minutes for the water to begin to simmer. Shortly, the water should be bubbling uniformly across the entire cooking surface.
7. Dial the thermostat switch back to the "off" position.
8. Tilt skillet to drain the water out of the skillet pan, into an appropriate pan or other container.
9. Lower the skillet, place the power on/off switch to the "off" position.

## OPERATING INSTRUCTIONS

1. Ensure that the electrical supply to the skillet is turned on.
2. Before cooking, be sure that the skillet's cooking surface is clean, and that the skillet is in the fully lowered position.
3. Place the skillet's power on/off switch to the "on" position.
4. Pre-heat skillet for approximately 10 minutes by turning the temperature control knob to the desired temperature setting (see TEMPERATURE APPLICATION CHART). The indicator light will remain lit, indicating the heater elements are activated, until the temperature setting has been reached. When the indicator light goes off, heaters are off, and pre-heating is complete.

**NOTE:** *When cooking egg and milk products, the skillet should not be preheated, as products of this nature adhere to hot cooking surfaces. These types of foods should be placed in the skillet before heating is begun.*

5. Place the food product into the skillet, distributing it evenly across the cooking surface. The indicator light will cycle on and off indicating the elements are cycling on and off. The cover should be off for most types of cooking or simmering. If cover is on, the vent cap can be used to reduce water content in product or allow steam to escape before lifting cover.
6. Pour the contents of the skillet into an appropriate container by tilting the skillet forward. Care should be taken to pour slowly enough to avoid splashing of the product.

**NOTE:** As with cleaning food soil from any cookware, and important part of skillet cleaning is to prevent foods from drying on. For this reason, cleaning should be completed immediately after cooked foods are removed. Refer to the "Care and Cleaning" Instructions for detailed skillet washing procedures.

**TEMPERATURE APPLICATION CHART**

Application	Approximate Dial Temperature	
	°F	°C
	Bain Marie	150-200
Slow Cooking	225	107
Braise	250-275	121-135
Sauce Pan, Low Griddle	325	163
Med. Griddle, Sauté, Steam	350	177
Hot Griddle	375	191
Fry, Shallow Oil	400-425	204-218

**CARE AND CLEANING**

Your Cleveland skillet must be cleaned regularly to maintain its fast, efficient cooking performance, and ensure its continued safe, reliable operation

1. Prepare a warm water and mild detergent solution in the skillet.
2. Remove food soil inside the skillet using a nylon brush. Do not use a metal bristle brush, as this may permanently damage the skillet's stainless steel surface.
3. Loosen food which is stuck to the skillet by allowing it to soak at a low temperature setting.
4. Rinse skillet interior thoroughly, then tilt to drain the rinse water.

5. Leave the cover open when the skillet is not in use. The condensate deflector on the cover may be removed for easier cleaning.
6. Turn off equipment power before going to next step.
7. Using mild soapy water and a damp sponge, wash the exterior of the skillet, (avoid soaking the control panel), rinse and dry.

**WARNING**

*Never hose down any skillet. There are electrical components on the skillet that are susceptible to water damage.*

**NOTE :** *For difficult cleaning applications, one of the following can be used: alcohol, baking soda, vinegar, or a solution of ammonia in water. Avoid the use of chloride cleansers, which may damage the skillet's stainless steel surface.*

**WARNING**

*Steel wool should never be used for cleaning the cooking surface or exterior of the skillet. Particles of the steel wool become embedded in the cooking surface and rust. This may corrode the skillet's stainless steel surface.*

•CAPACITIES: (in 4 oz. servings) (Other sizes may be calculated.

10 Gallons/40 liters . . .320

•Many local codes exist and it is the responsibility of the owner and installer to comply with those codes.

•Cleveland Range equipment is built to comply with applicable standards for manufacturers. Included among those approval agencies are: UL, A.G.A., NSF, ASME/N.Bd., CSA, CGA, ETL, and others.

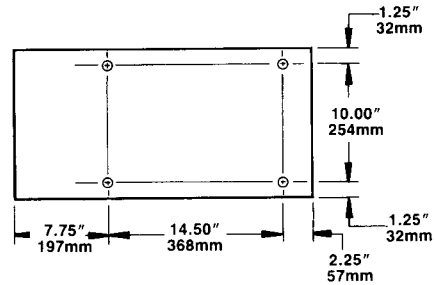
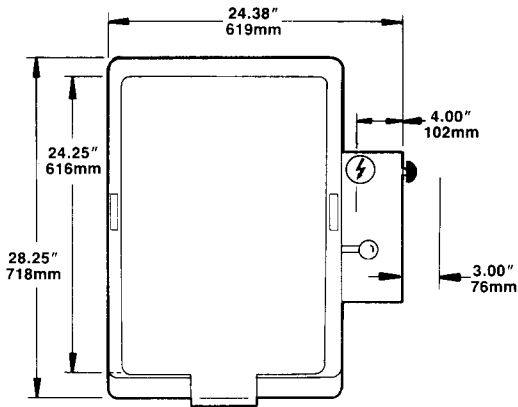

5/16" - 18 THREADED FERRULES  
WELDED TO UNDERSIDE OF BASE

**MOUNTING DIAGRAM  
TOP VIEW**

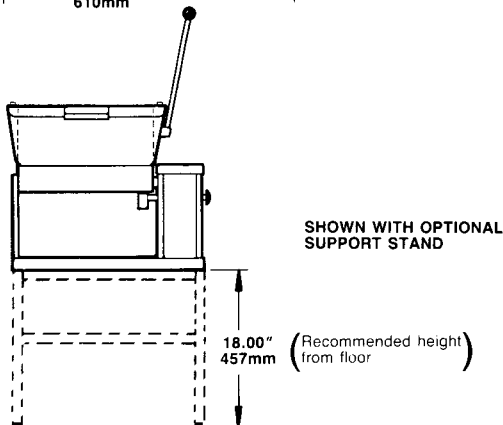
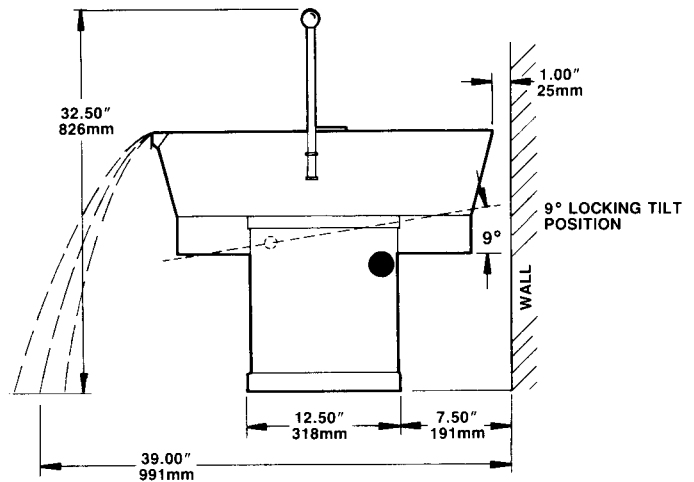
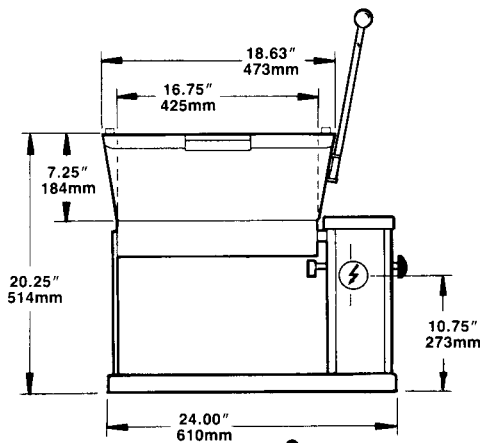

**SHOWN WITH OPTIONAL  
SUPPORT STAND**

ELECTRIC ⚡											CLEARANCE	
		208 VOLTS			240 VOLTS			220 /380 VOLTS			RIGHT = 3.00" LEFT = 0" REAR = 1.00"	
		AMPS			AMPS			AMPS				
GALS.	LITERS	KW	1 PH	3 PH	KW	1 PH	3 PH	KW	1 PH	3 PH		
10	40	7.4	35.4	20.5	7.8	32.7	18.9	6.5	N/A	9.9		

DUAL VOLTAGE OF 220/380 SHOWN ON CHART REQUIRES A FOUR WIRE, THREE PHASE ELECTRICAL SUPPLY.

SCALE .75" = 1'  
SECT. XII PAGE 2  
1298  
Litho in USA.

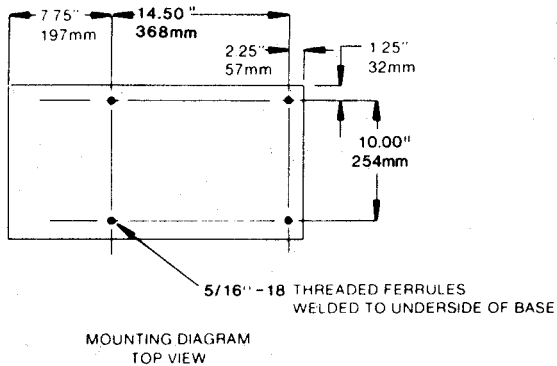

**SHORT FORM SPECIFICATION**  
 Shall be CLEVELAND, round Tilting Skillet, Model SET-15; \_\_\_\_KW \_\_\_\_volts, 15 gallon capacity (56 liters). Complete with Thermostatic and Safety Controls; Bead Blasted cooking surface; Lift-off Cover with adjustable vent. All Stainless Steel construction.

- CAPACITIES: (in 4 oz. servings) (Other sizes may be calculated)  
 15 Gallons/56 liters...480
- Many local codes exist and it is the responsibility of the Owner and Installer to comply with those codes.
- Cleveland Range equipment is built to comply with applicable standards for manufacturers. Included among those approval agencies are: UL, A.G.A., NSF, ASME/N.Bd., CSA, CGA, ETL, and others.

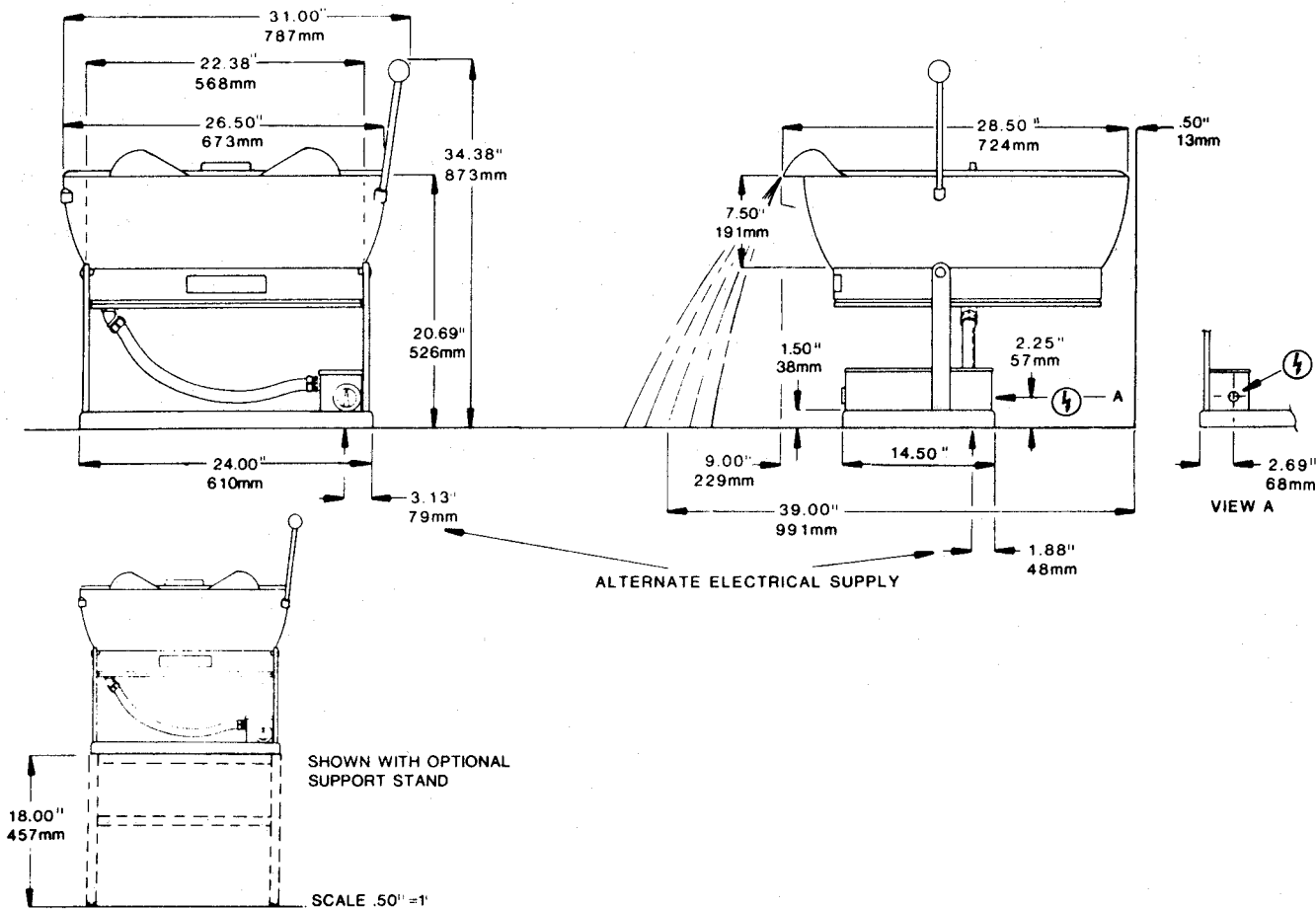

ELECTRIC ⚡										CLEARANCE		
208 V			240 V			220/380 V			240/416 V			RIGHT = 4.00" LEFT = 4.00" REAR = 0.50"
KW	AMPS 1PH	AMPS 3PH	KW	AMPS 1PH	AMPS 3PH	KW	AMPS 1PH	AMPS 3PH	KW	AMPS 1PH	AMPS 3PH	
7.4	35.4	20.5	7.8	32.7	18.9	6.5	N/A	10.0	7.8	N/A	11.0	

DUAL VOLTAGE OF 220 / 380 SHOWN ON CHART REQUIRE A 4 WIRE, 3 PHASE ELECTRICAL SUPPLY.

Cleveland Range reserves right of design improvement or modification, as warranted.

SCALE .75" = 1"  
 SECT. XII PAGE 4  
 0290  
 Litho in USA.

# MODEL SET - 10 SKILLET OPERATING CONTROLS AND INDICATORS

For your better understanding and confidence, the following explanation of the control system on this skillet is offered.

ITEM NO.	DESCRIPTION	FUNCTION
5 - 6	Semi Tilt Arm and Knob (Control Housing Dwg.)	When skillet is in a tilted position, push knob in and rotate. This will keep the skillet in a semi tilted position when lowered.
13	ON/OFF Toggle Switch (Control Housing Dwg.)	Controls electric power to the skillet.
15	Pilot Light (Control Housing Dwg.)	The pilot light cycles on and off, indicating power to the elements, controlled by the thermostat.
20	Thermostat Control Knob (Control Housing Dwg.)	This control knob allows the operator to select various heat increments for operating the skillet.
5 - 6	Tilting Handle and Knob (Skillet Bottom Dwg.)	This handle allows the operator to manually tilt the skillet.

# MODEL SET - 15 SKILLET OPERATING CONTROLS AND INDICATORS

For your better understanding and confidence, the following explanation of the control system on this skillet is offered.

ITEM NO.	DESCRIPTION	FUNCTION
3	Pilot Light (Control Housing Dwg.)	The pilot light cycles on and off, indicating power to the elements, controlled by the thermostat.
4	ON/OFF Toggle Switch (Control Housing Dwg.)	Controls electric power to the skillet.
6	Thermostat Control Knob (Control Housing Dwg.)	This control knob allows the operator to select various heat increments for operating the skillet.
16 - 17	Handle (Skillet Bottom Dwg.)	This handle allows the operator to manually tilt the skillet.

# **DON'T BE FOOLED BY GENERIC PARTS**

**Short term savings could create a major expense.  
Please read the following points:**

- The use of generic parts **will void** existing warranties.
- Agency certifications such as CSA, ASME/Bd., CGA, AGA, etc. are based on equipment using certified parts. The use of generic parts may conflict with certified specifications.
- The use of other than original manufacturer's authorized parts could invalidate possible insurance claims.
- Cleveland Range **cannot** stand behind equipment that has been modified with generic parts.

**To ensure safe and dependable equipment,  
use only original manufacturer's authorized parts.  
Please contact your AUTHORIZED SERVICE  
COMPANY for parts and service.**

---

**Use genuine CLEVELAND replacement parts.**

# MODEL SET-10 SKILLET

## PARTS LIST-SKILLET BOTTOM

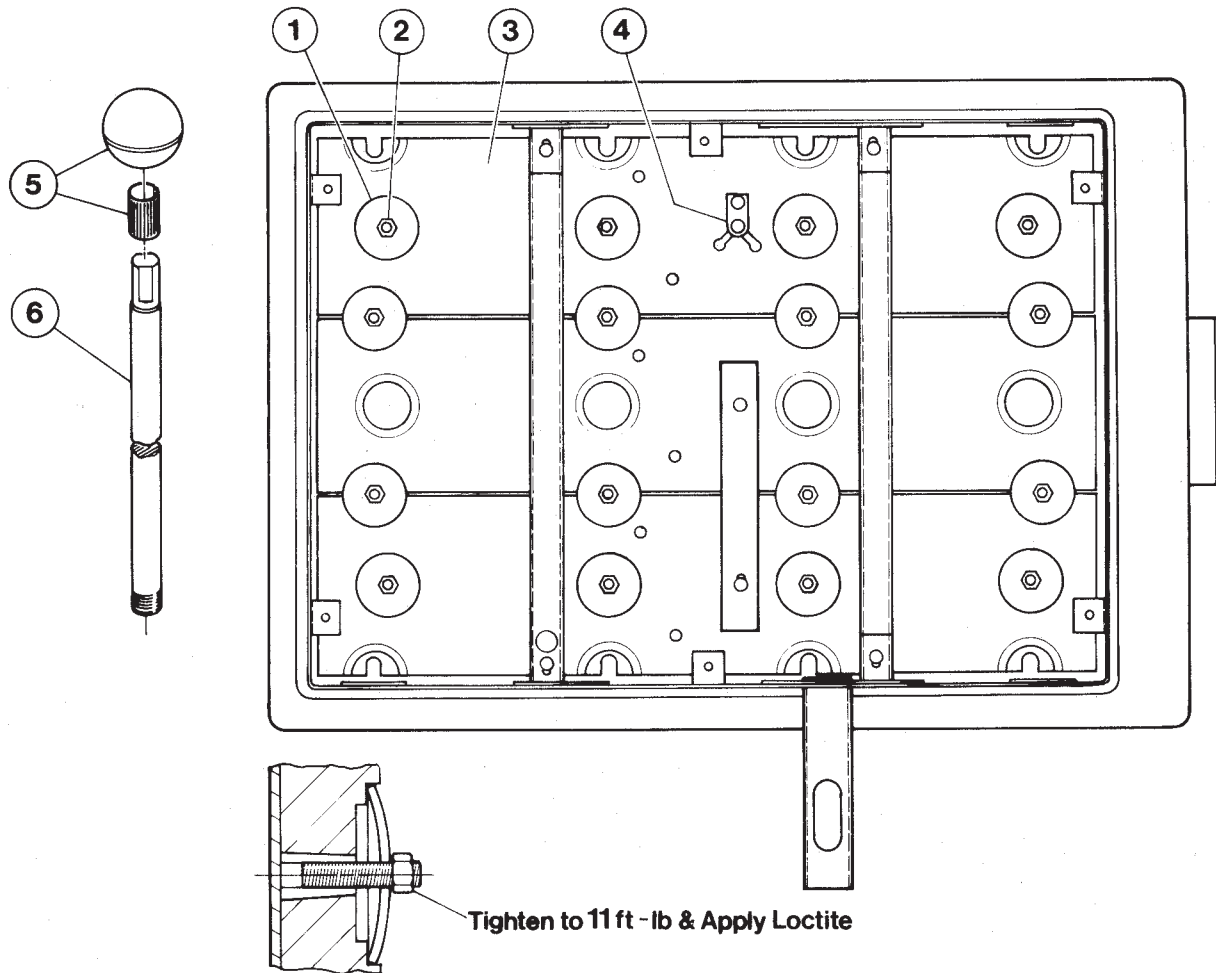

Item No.	Part No.	Description	Qty.
1	2231500	Washer, Spherical	16
2	F-241	Nut, 5/16 - 18	16
3	2231499	Element Block Assembly	3
4	2232100	Thermostat, High Limit (575°F) (302°C)	1
5	2238500	Knob, Handle	1
6	2240600	Handle	1

Use only replacement parts which are factory supplied as to preserve the certification of Underwriters Laboratories, American Gas Association, Canadian Standards Association or Canadian Gas Association (as applicable). The use of other than factory supplied replacement parts will void the warranty.

# MODEL SET-10 SKILLET

## PARTS LIST-CONTROL HOUSING

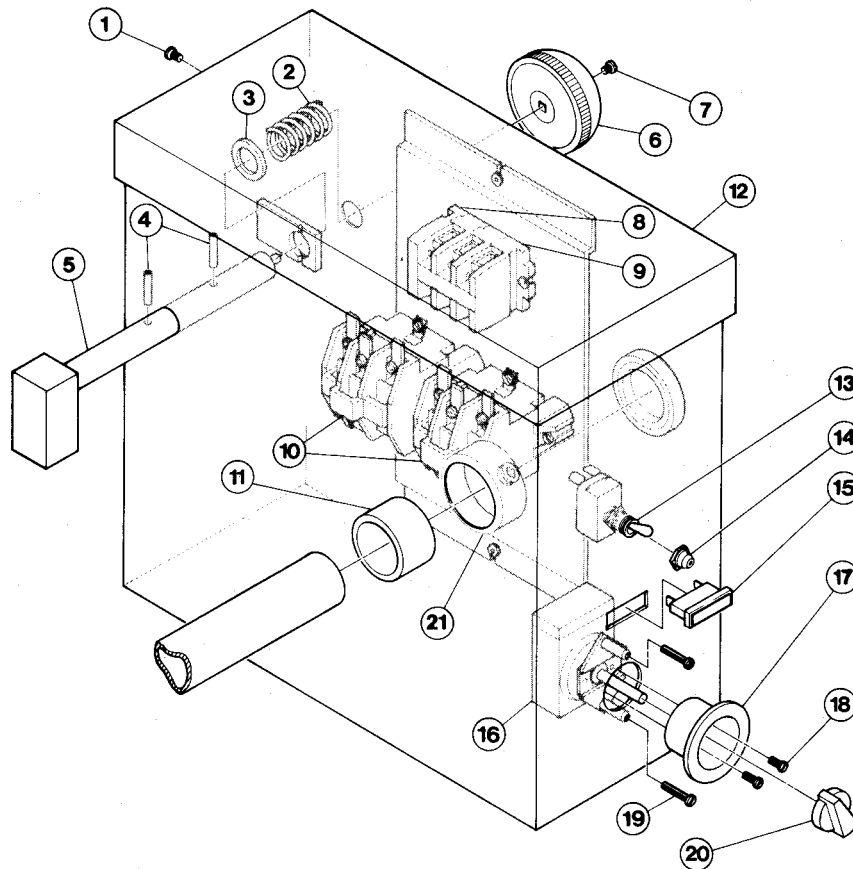

Item No.	Part No.	Description	Qty.
1	F-12	Screw, Cover, 10 - 24 x 1/2"	1
2	2234200	Spring	1
3	2234100	Washer	1
4	2241200	Pin	2
5	2238099	Semi Tilt Arm	1
6	2234300	Knob	1
7	F-87	Screw (Knob)	1
8	050070	Terminal Block - End Section	1
9	050069	Terminal Block	3
10	077062-1	Contactora, 208 - 240V	1
11	2234400	Bronze Trunnion Bearing	2
12	2240800	Console Cover	1
13	2235100	Switch, Toggle, ON/OFF, DPST	1
14	2236600	Rubber Boot	1
15	2235000	Pilot Light	1
16	2234600	Thermostat	1
17	2234800	Bezel (°F)	1
	2234801	Bezel (°C)	
18	F-96	Screw, Bezel, 6 - 32 x 1/4"	2
19	F357	Screw, Termostat, 6 - 32 x 5/8"	2
20	2234900	Knob, Thermostat	1
21	2240700	Trunnion Lock Collar	1

Use only replacement parts which are factory supplied as to preserve the certification of Underwriters Laboratories, American Gas Association, Canadian Standards Association or Canadian Gas Association (as applicable). The use of other than factory supplied replacement parts will void the warranty.

# MODEL SET-10 SKILLET PARTS LIST-FAUCET

Item No.	Part No.	Description	Qty.
1	SE50020	Hot Water Stem Assy.	1
2	SE50021	Cold Water Stem Assy.	1
3	SE50022	Yoke Connection Kit	1
4	2202400	"O" Ring	1
5	2202300	Retaining Ring	1
6	2202200	Spout Nut	1
7	2202100	3/4" Spout	1
8		3/4" Spout with Aerator (please order Item No. 4,5,6,7)	1
9	2201900	Single Pantry Control Valve (c/w Item No. 2)	1
10	2202000	Double Pantry Control Valve (c/w Item No. 1, 2, 3)	1
Not Shown	2308800	Faucet Bracket	

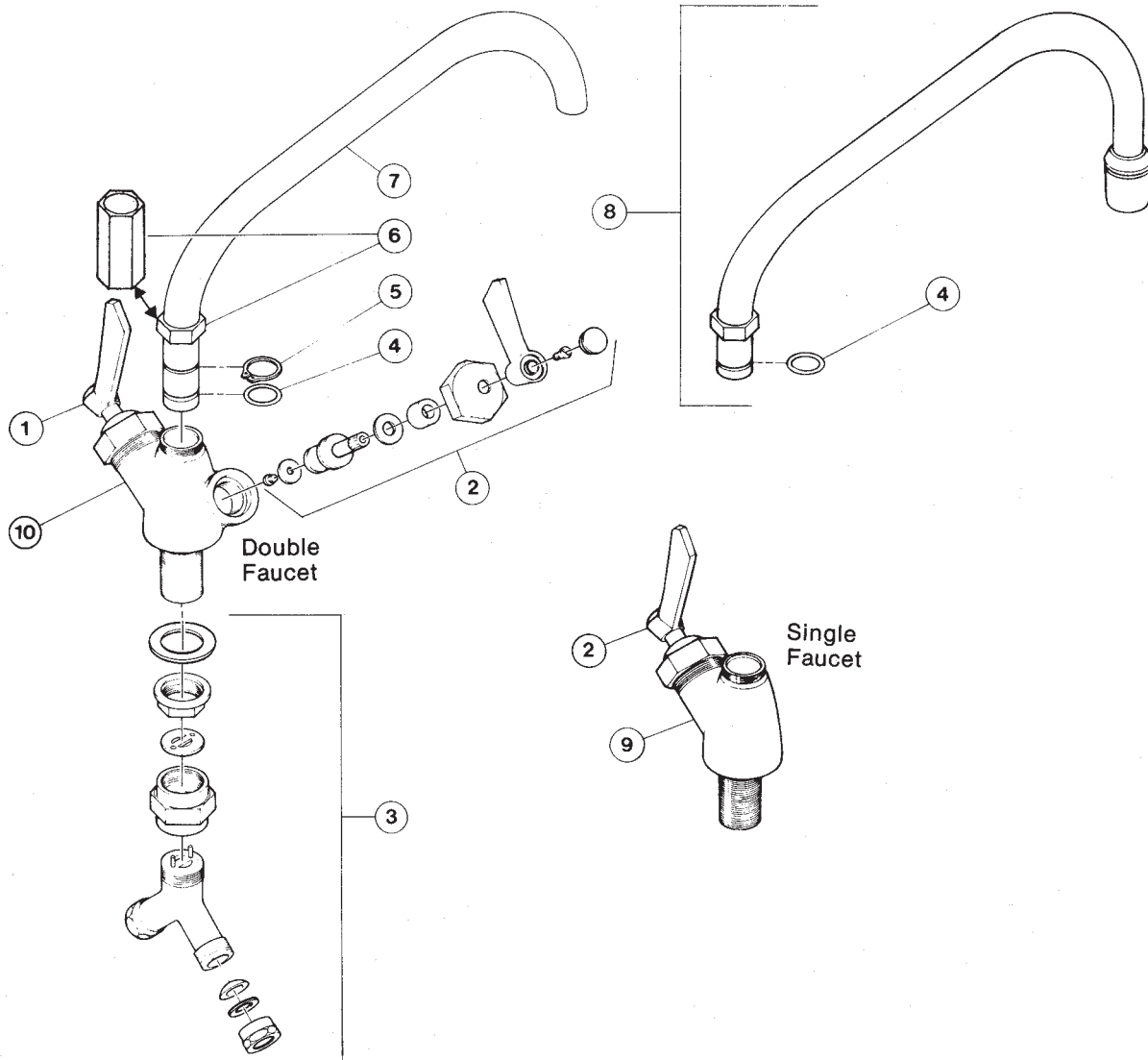

Use only replacement parts which are factory supplied as to preserve the certification of Underwriters Laboratories, American Gas Association, Canadian Standards Association or Canadian Gas Association (as applicable). The use of other than factory supplied replacement parts will void the warranty.

# MODEL SET-15 SKILLET BOTTOM AND COVER VENT CAP

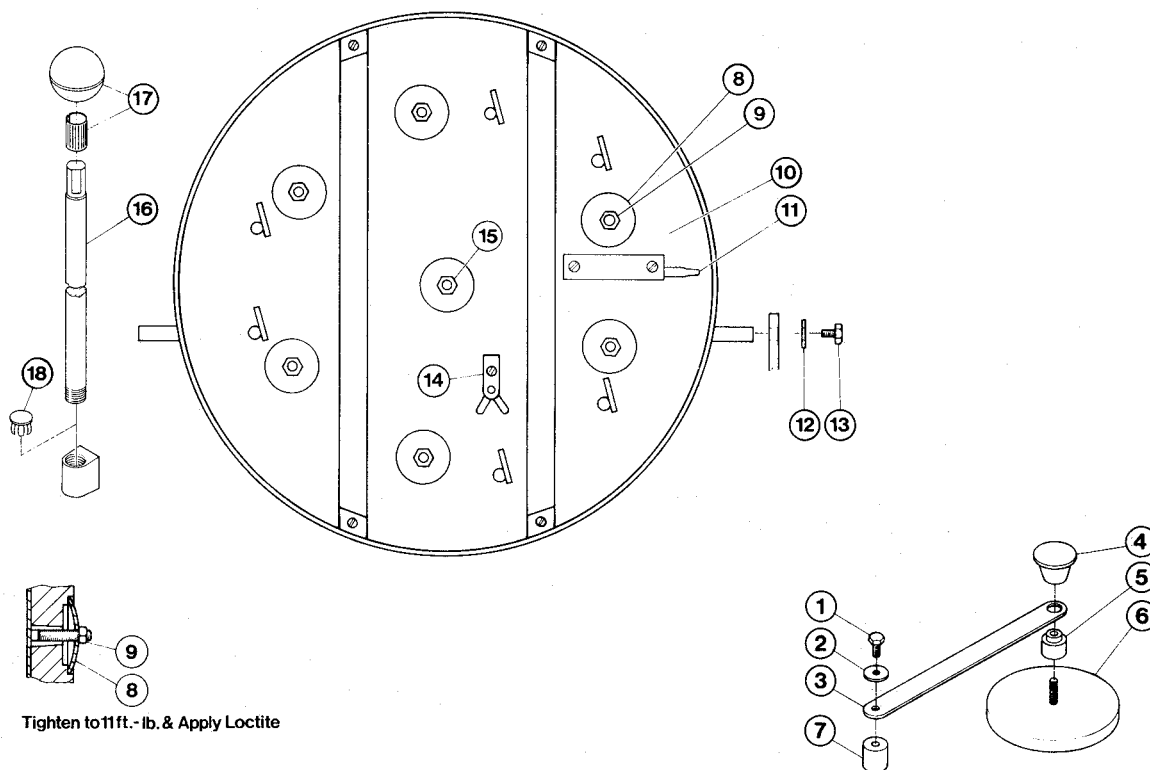

Item No.	Part No.	Description	Qty.
1	2211500	Screw, 1/4-20 x 3/8"	1
2	2211400	Washer	1
3	2211100	Support Arm	1
4	2209300	Knob	1
5	2211300	Spacer	1
6	2211099	Cover	1
7	2211200	Spacer	1
8	2275300	Washer, Spherical	7
9	2273900	Nut, 5/16-18	6
10	2276097	Element Block Assembly	1
11	2234600	Thermostat	1
12	1480800	Washer	2
13	2274000	Bolt, 5/16-18 x 1/2"	2
14	2277400	Thermostat, High Limit (575F, 302C)	1
15	1480800	Cover Spacer	1
16-17	2240600	Handle with Knob	1
17	2238500	Knob, Handle	1
18	2273400	Plub Button	1

Use only replacement parts which are factory supplied as to preserve the certification of Underwriters Laboratories, American Gas Association, Canadian Standards Association or Canadian Gas Association (as applicable). The use of other than factory supplied replacement parts will void the warranty.

# MODEL SET-15 SKILLET CONTROL HOUSING

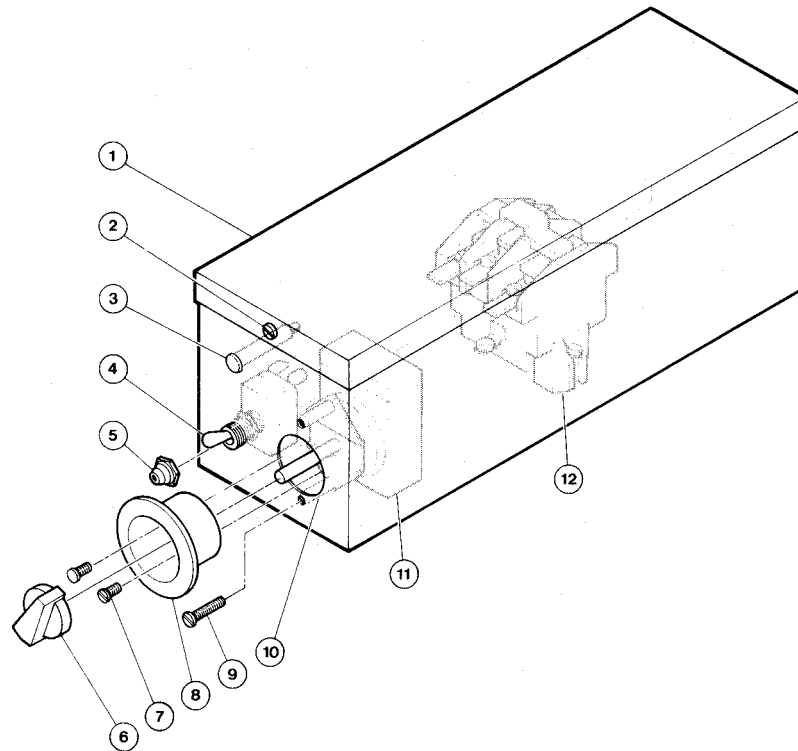

Item No.	Part No.	Description	Qty.
1	2274900	Cover, Control Box	1
2	F-12	Screw, Cover, 10-24 x 1/2"	2
3	2275200	Pilot Light	1
4	2235100	Switch, Toggle, ON/OFF	1
5	2236600	Rubber Boot	1
6	2234900	Knob, Thermostat	1
7	F357	Screw, Bezel, 6-32 x 5/8"	2
8	2234800	Bezel (°F)	1
	2234801	Bezel (°C)	
9	F-96	Screw, Thermostat, 6-32 x 1 1/4"	2
10	2234700	Spacer	2
11	2234600	Thermostat	1
12	2276200	Contactors, 208-240V	1

Use only replacement parts which are factory supplied as to preserve the certification of Underwriters Laboratories, American Gas Association, Canadian Standards Association or Canadian Gas Association (as applicable). The use of other than factory supplied replacement parts will void the warranty.

# MODEL SET-15 SKILLET PARTS LIST-FAUCET

Item No.	Part No.	Description	Qty.
1	SE50020	Hot Water Stem Assy.	1
2	SE50021	Cold Water Stem Assy.	1
3	SE50022	Yoke Connection Kit	1
4	2202400	"O" Ring	1
5	2202300	Retaining Ring	1
6	2202200	Spout Nut	1
7	2202100	3/4" Spout	1
8		3/4" Spout with Aerator (please order Item No. 4,5,6,7)	1
9	2201900	Single Pantry Control Valve (c/w Item No. 2)	1
10	2202000	Double Pantry Control Valve (c/w Item No. 1, 2, 3)	1
Not Shown	2302200	Faucet Bracket R/H	1
Not Shown	2302201	Faucet Bracket L/H	1

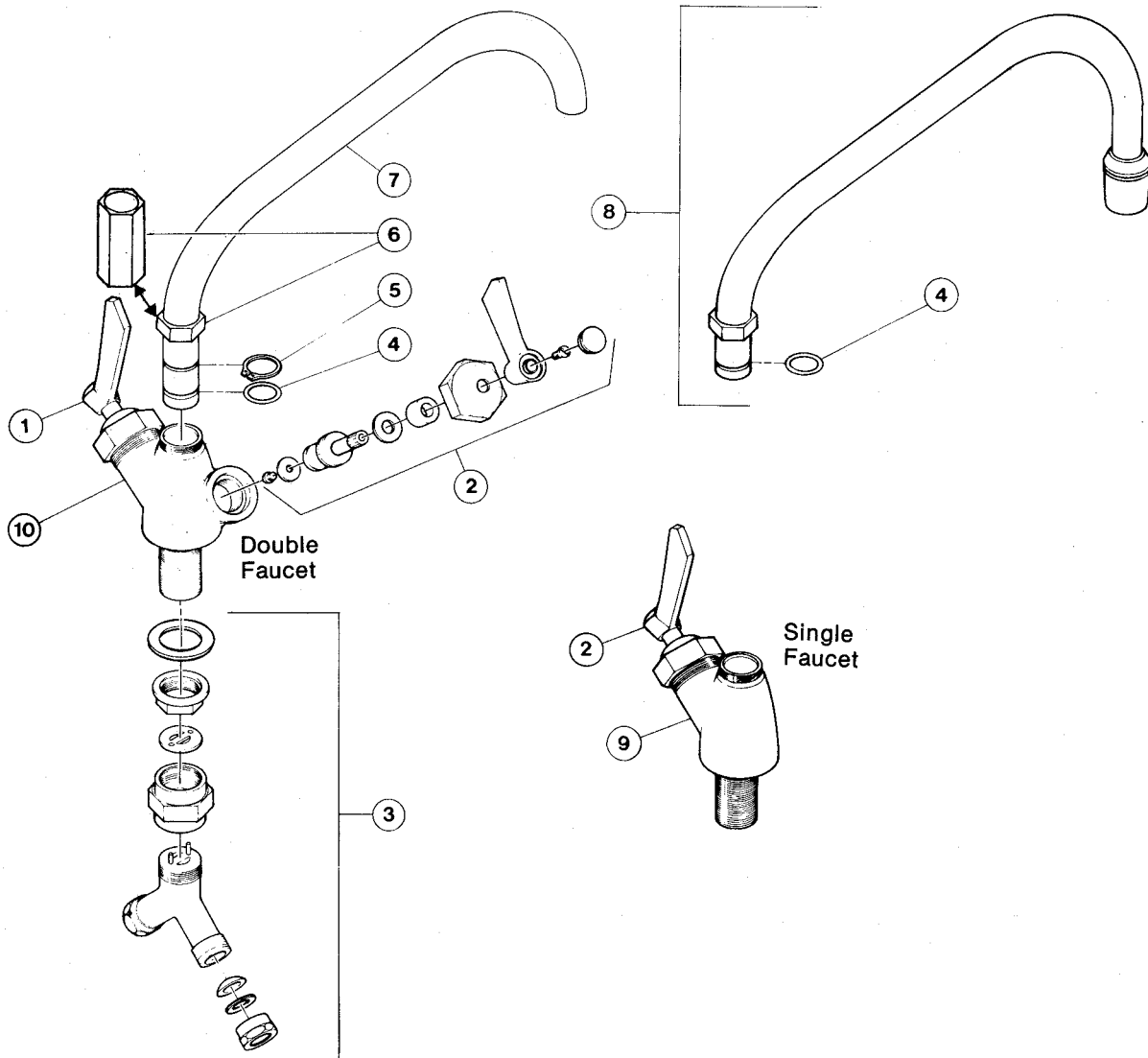

Use only replacement parts which are factory supplied as to preserve the certification of Underwriters Laboratories, American Gas Association, Canadian Standards Association or Canadian Gas Association (as applicable). The use of other than factory supplied replacement parts will void the warranty.

# TABLE TOP ELECTRIC SKILLETS SERVICING GUIDE

This section contains servicing information intended for use by Authorized Service Personnel.

## A/ **PROBLEM:** Skillet fails to heat with pilot light on.

	<b>Probable Cause</b>	<b>Test and Remedy</b>
1.	Faulty contactor(s)	Check coil(s) and contacts of contactor(s). Replace if necessary.
2.	Faulty wiring	Check wiring to contactor(s). Replace if necessary.

## B/ **PROBLEM:** Skillet fails to heat with pilot light off.(power switch must be on and thermostat set).

	<b>Probable Cause</b>	<b>Test and Remedy</b>
1.	Main power to skillet is off	Check incoming power at terminal block.
2.	Defective power switch	With power source off, remove wiring from switch and test for continuity. Or with wiring connected and unit on, check for voltage across terminals of switch. Voltage indicates an open circuit. Replace switch if necessary.
3.	Defective thermostat	Shut the unit off and disconnect wiring from thermostat. Check continuity of thermostat. An open circuit while in the "ON" position indicates a faulty thermostat. Or with thermostat connected and unit on, check for voltage across thermostat. Voltage indicates an open circuit, indicating a faulty thermostat.
4.	Defective high limit thermostat	Repeat above procedure used for defective thermostat.

## C/ **PROBLEM:** Skillet fails to reach maximum 425° F at #10 setting.

	<b>Probable Cause</b>	<b>Test and Remedy</b>
1.	Defective or improperly adjusted thermostat	As unit shuts off early, check for voltage across thermostat terminals. If there is voltage across terminals, re-calibrate or replace thermostat.
2.	Defective safety thermostat	Repeat above procedure used for defective thermostat.

## D/ **PROBLEM:** Skillet has uneven heat over pan surface.

	<b>Probable Cause</b>	<b>Test and Remedy</b>
1.	Defective contactor	Check contactor for burned out contacts and replace if required.
2.	Defective heating element block	Check for continuity between element terminals and from terminals to ground. Either an open circuit between terminals or a short to ground indicates a faulty element. Replace if necessary.
3.	Faulty wiring	Inspect condition of wires and connections to elements and contactors. Repair if necessary.
4.	Uneven torquing of aluminum heating blocks	Follow element block torquing procedure.

## HEATING ELEMENT REMOVAL

1. Tilt the skillet forward to access bottom cover plate.
2. Make sure power switch and external circuit breaker (at fuse box or breaker panel) are off.
3. Remove screws from bottom cover plate. Remove plate.
4. Remove all 7/16 inch nuts and washers from stainless retaining plate located at rear of skillet pan.
5. Remove screws and tooth lock washer from retaining bars and slide thru open end where retaining plate was previously removed.
6. Disconnect electrical lead wires from elements.
7. Remove 5/16 inch nuts and spherical washers from heating element blocks. Care should be taken when removing nuts and washers to prevent breaking studs.
8. Remove heating elements blocks. Replace as needed.

**NOTE:** With new element block in place re-tighten nuts on spherical washers with a torque wrench to 11ft-lbs torque.

9. Replace retaining bars, retaining back plate and bottom cover.
10. Switch external power back on and return skillet to operating position.

**WARNING:** Heating element blocks are very heavy. Use care when handling.

## HEATING ELEMENT BLOCK TORQUING

Uneven torquing of heating element block retaining plate nuts may cause uneven heating of the cooking surface. To retorque, proceed as follows:

1. Tilt the skillet forward.
2. Ensure that the power switch and the external circuit breaker (at fuse box or breaker panel) are off.
3. Remove the bottom cover plate.
4. Loosen the 5/16 inch nuts on the spherical washers.
5. Using a torque wrench, retighten the nuts to 11ft-lbs torque.
6. Replace the bottom cover plate.

# MODEL SET-10 SKILLET WIRING DIAGRAM

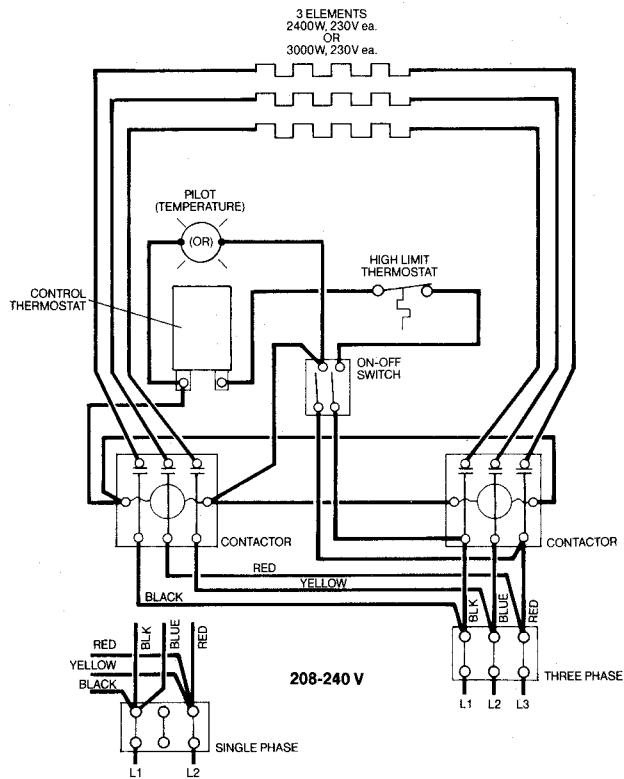

VOLTS	KW	PH	AMPS
208	5.9	1	28.4
		3	16.4 per PH
	7.4	1	35.4
220	6.5	3	20.5 per PH
		1	29.8
230	7.2	3	7.2 per PH
		1	31.3
240	7.8	3	18.0 per PH
		1	32.7
		3	18.9 per PH

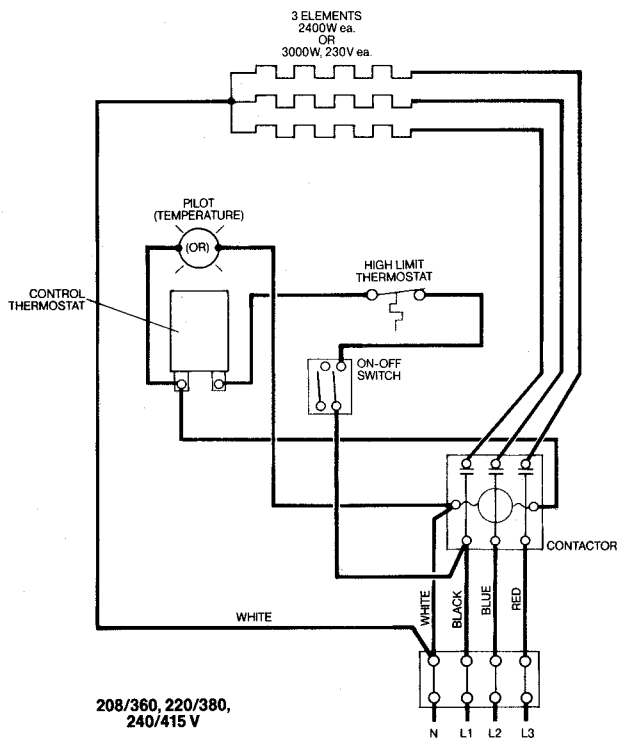

VOLTS	KW	PH	AMPS
208/360	5.9	3	9.4 per PH
		3	11.8 per PH
220/380	6.5	3	9.9 per PH
240/415	7.8	3	10.9 per PH

# MODEL SET-15 SKILLET WIRING DIAGRAM

208-240 V 1 ph

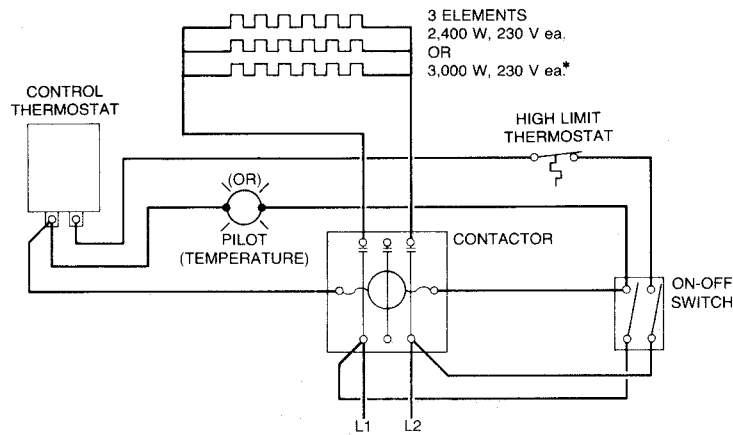

	KW	AMPS
208 V, 1 PH	5.9	28.4
208 V, 1 PH	7.4	35.4
220 V, 1 PH	6.5	29.8
230 V, 1 PH	7.2	31.3
240 V, 1 PH	7.8	32.7

208 - 240 3 ph

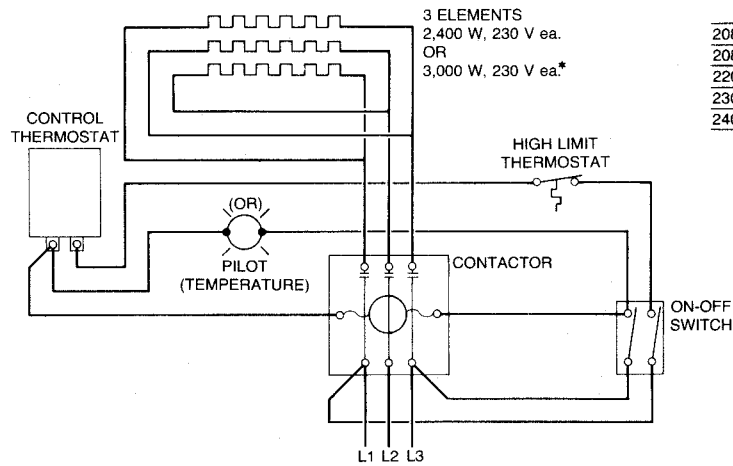

	KW	AMPS
208 V, 3 PH	5.9	16.4 per PH
208 V, 3 PH	7.4	20.5 per PH
220 V, 3 PH	6.5	17.2 per PH
230 V, 3 PH	7.2	18.0 per PH
240 V, 3 PH	7.8	18.9 per PH

208/360, 220/380, 240/416 V, 3 ph

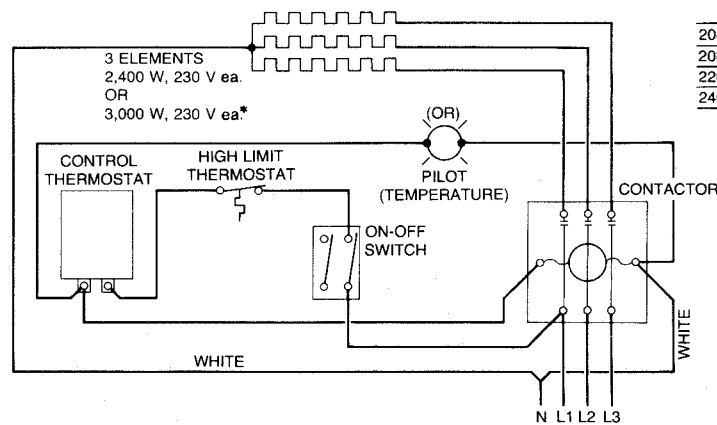

	KW	AMPS
208/360 V, 3 PH	5.9	9.4 per PH
208/360 V, 3 PH	7.4	11.8 per PH
220/380 V, 3 PH	6.5	9.9 per PH
240/416 V, 3 PH	7.8	10.9 per PH

\* 3,000 W OPTION AVAILABLE FOR 208 V ONLY