



INSTALLATION AND OPERATING INSTRUCTIONS

Dante SERIES

GAS CHAR BROILERS

Models: **XX & CH**

**INTENDED FOR OTHER THAN HOUSEHOLD USE
RETAIN THIS MANUAL FOR FUTURE REFERENCE
BROILER MUST BE KEPT CLEAR OF COMBUSTIBLES AT ALL TIMES**

IMPORTANT INSTRUCTIONS

After the gas supply has been connected to your unit, it is extremely important to check piping for possible leaks. To do this, use soap and water solution or solutions which are expressly made for this purpose. **DO NOT USE** matches, candles, flames, or other sources of ignition since these methods are extremely dangerous.

Post in a prominent location instructions to be followed in the event you smell gas. Obtain these instructions from your local gas supplier.

FOR YOUR SAFETY

Do not store or use gasoline or other flammable vapors and liquids in the vicinity of this or any other appliance.

WARNING

Improper installation, adjustment, alteration, service or maintenance can cause property damage, injury or death. Read the Installation, Operating and Maintenance Instructions thoroughly before installing or servicing this equipment.

This equipment has been engineered to provide you with year round dependable service when used according to the instructions in this manual and standard commercial kitchen practices.



P/N XXCH101 3/05

BAKERS PRIDE OVEN CO., INC.

30 Pine Street
New Rochelle, NY 10801

(914) 576-0200 Phone
(914) 576-0605 Fax
(800) 431-2745 US & Canada

www.bakerspride.com Web Address
info@bakerspride.com e-mail

INDEX

I. INSTALLATION INSTRUCTIONS

SECTION	ITEM	PAGE
1	General Description	4
2	Installation	4
3	Clearances	4
4	Gas Connection	4
5	Burners	5
6	Radiants	5
7	Top Grates	6
8	Lighting	6
9	Griddle Plates	6
10	Additional Installation Requirements	6
11	Installation with Casters	6

II. OPERATING INSTRUCTIONS

SECTION	ITEM	PAGE
1	Lighting Procedure	7
2	Broiling Procedure	7
	(a) Seasoning	7
	(b) Steaks and Chops	7
	(c) Hamburgers	7
	(d) Thickness	7
	(e) Cooking Tools	7
3	Helpful Hints	7
4	Maintenance	8
	(a) Service	8
	(b) Care and Cleaning of Top Grates	8
	(c) Grease Collection	8
	(d) Cleaning Tools	8
5	Average Production Guide	8

III. TROUBLESHOOTING GUIDE

SECTION	ITEM	PAGE
1	Burner Flame Adjustment	9
2	Pilot Flame Adjustment	9
3	Lack of Heat	9
4	One Burner Fails to Light	9
5	Valve Assembly Views	10

IV. PARTS LISTS & EXPLODED VIEWS

ITEM	PAGE
Models: XX-4, -6, -8, -10 & 12 Parts Lists & Exploded Views	11
Models: CH-6, -8, -10, -12 & 14 Parts List & Exploded View	14

V. WARRANTY

ITEM	PAGE
Bakers Pride Limited Warranty	16

I. INSTALLATION INSTRUCTIONS

1. GENERAL:

The instructions in this manual apply to all XX series and CH series Broilers.

The XX series may include the following options:

- Ceramic briquettes designated by a GS Suffix on the model number.

2. INSTALLATION:

- (a) **In USA**, INSTALLATION of this broiler must conform with the latest edition of the National Fuel Gas Code, ANSI Z223.1 and/or local codes.
- (b) **In CANADA**, INSTALLATION must conform with the latest edition of the National Gas Installation Code, CAN/CGA-B149.1 or the Propane Installation Code, CAN/CGA-B149.2, as applicable and/or local codes.

3. ACCEPTABLE CLEARANCES:

Due to intense heat generated by radiation, these broilers should be installed in non-combustible locations only including above the grate level.

MINIMUM CLEARANCE FROM NON-COMBUSTIBLE CONSTRUCTION		
	<i>Series XX</i>	<i>Series CH</i>
Right Side	0 inches	0 inches
Left Side	0 inches	0 inches
Back	0 inches	0 inches

4. GAS CONNECTION:

The gas pressure regulator supplied must be installed at the gas inlet of each broiler. Each regulator is adjusted to yield a manifold pressure of 5 in. water column for natural gas or 10 in. water column for propane gas. No pressure regulator is required for propane gas in Canada.

RECOMMENDED MINIMUM GAS SUPPLY LINES ARE LISTED BELOW		
All XX Models	CH-4 thru CH-8	CH-10 thru CH-16
3/4"	1"	1 1/2"

For units using propane gas, supply lines less than 1/2" inside diameter should not be used, even for a small unit.

On the XX and CH series, the gas connection is located on the right rear of the unit.

BE SURE TO CAP WHICHEVER SIDE IS NOT CONNECTED.

NOTE: A shut-off valve in a readily accessible location must be mounted on the gas supply line before the unit.

When making gas pipe connections, pipe joint compound resistant to the action of liquefied petroleum gases should be used.

The broiler and its individual shutoff valve must be disconnected from the gas supply piping system during any pressure testing of that system at test pressures in excess of 1/2 psig (3.45 kPa).

The broiler must be isolated from the gas supply piping system by closing its individual manual shutoff valve during any pressure testing of the gas supply piping system at test pressures equal to or less than 1/2 psig (3.45 kPa).

5. BURNERS:

Check to see that AIR MIXER CAPS on the front of all burners are tightened and adjusted, allowing half the opening to show. Install the burners and deflector shields first following the steps below.

- (a) Install all burners with deflector shield assemblies attached.
- (B) Place the front of the burner into the valve assembly by fitting the center hole of the mixer cap over the brass orifice.
- (c) Drop the rear end of the burner over the burner support pin on the back of the unit.

6. RADIANTS:

Mount the "V" shaped radiants over the burners with each end mounted on special supports on the front and rear of the chamber. A radiant should be mounted over each burner assembly.

GS Ceramic Briquettes Option:

The radiants supplied for the GS option are flattened to allow for the installation of an expanded metal grate. The grate is installed directly on top of the flattened radiant burner shield. Ceramic briquettes are installed on the grate as shown:

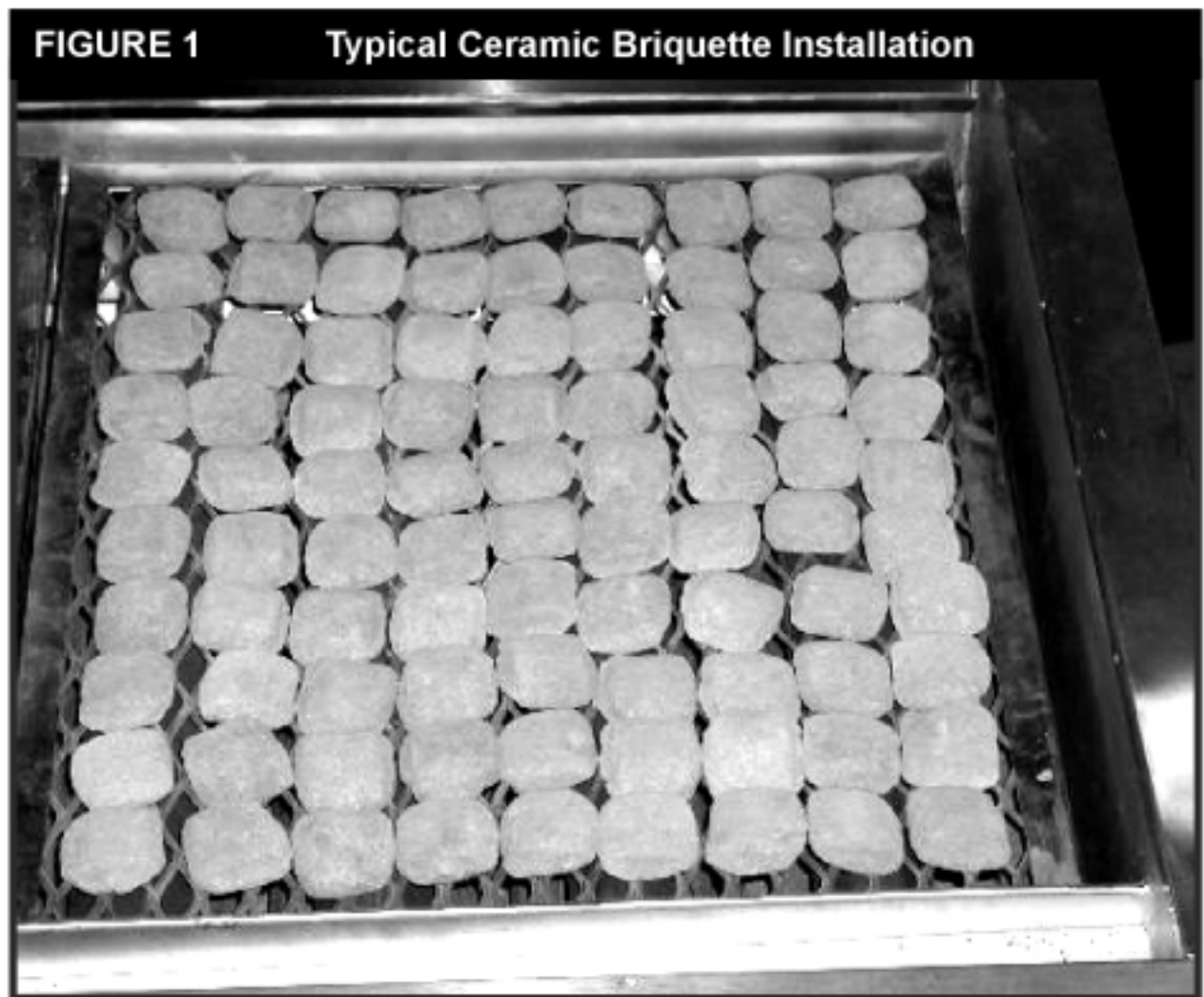

7. TOP GRATES:

Place a grate over each of the radiants. For normal operation, the pointed side of the grate is facing up. For use with foods that require extra support, the flat side may be used.

On XX Models, grates can be placed on three levels; two positions are built into the rear of the unit; the third position requires a special adapter. On CH models, three positions are already built into the rear of the unit.

8. LIGHTING:

Each burner on the base char broiler has a standing pilot burner that must be lit before the burners can be lit. To light the pilot burners:

- (a) Turn all broiler valves to the off position.
- (b) Remove each top grate and radiant.
- (c) Open main gas SHUT-OFF valve (supplied by customer).
- (d) Allow air to bleed from the gas line through the pilot burners.
- (e) Light the pilot burners using a lit taper.
- (f) Turn the burner control valves "ON" to light the burners.
- (g) If any burner fails to light, turn the burner valves to "OFF", wait five minutes and repeat the above procedure.
- (h) After all burners have been ignited properly, turn each burner valve "OFF" and allow the unit to cool. NOTE: Make sure that the pilot burners stay lit.
- (i) Replace radiants and top grates.
- (j) Each burner may now be adjusted to the desired flame size by turning the individual burner valve handle.
- (k) To shut down the unit, turn all valves "OFF"

Wait five minutes before attempting to re-light.

NOTE: The pilot burners will stay lit until the gas supply to the unit is turned "OFF".

9. GRIDDLE PLATE:

Griddle plates should not cover more than 50% of the BROILING area. Each Griddle Plate fits on top of two grates (one 4 1/2" and one 6"). It is not necessary to remove the top grates and radiants before installing the griddle plate.

10. ADDITIONAL INSTALLATION INSTRUCTIONS

- (a) Keep the area around the broiler free and clear of combustible materials.
- (b) The provision of an adequate air supply to your broiler is essential. Provide for sufficient outside air to enter the broiling area and assure that this airflow is not obstructed.
- (c) Air enters the burner area from the front and bottom of your broiler. Assure that these areas are kept open and unobstructed.
- (d) Servicing is accomplished through the front and top of the broiler. Assure that these areas are kept unobstructed for proper servicing and operation.

11. INSTALLATION WITH CASTERS

- (a) Install the casters with the wheel brakes on the front of the appliance.
- (b) Installation should be made with a connector that complies with the latest edition of the Standard for Connectors for Movable Gas Appliances, ANSI Z21.69 in the USA (CAN/CGA-6.16 in Canada), and a quick disconnect device that complies with the latest edition of the Standard for Quick Disconnect Devices for use with gas fuel, ANSI Z21.41 in USA (CAN 1-6.7 in Canada) and adequate means must be provided to limit the movement of the appliance without depending upon the connector and any quick disconnect device or its associated piping to limit the appliance movement.
- (c) The restraint should be attached to the legs on which the casters are mounted.
- (d) If disconnection of the restraint is necessary, the restraint should be reconnected after the appliance has been returned to its originally installed position.

II. OPERATING INSTRUCTIONS

1. LIGHTING PROCEDURE:

See section 8 of INSTALLATION INSTRUCTIONS. Once the pilot burners are lit, the broiler may be turned "ON" or "OFF" by turning the control valves on or off as necessary.

2. BROILING PROCEDURE:

BROILER TOP GRATES MUST BE HOT ENOUGH TO MAKE BLACK CHAR-MARKS WHEN STARTING TO BROIL.

Adequate pre-heating time is necessary for the food to release from the broiler and to cook properly. Allow the unit to pre-heat for 45 minutes to 1 hour before broiling.

(a) SEASONING:

Marinades with oil and vinegar or wine bases are best applied at least 1 to 2 hours before broiling. Spice mixes, such as flavored salt etc., should be applied 10 to 30 minutes before broiling. Tomato and sugar based products, such as barbecue sauces etc., have a tendency to burn and should be used prior to removing the food from the broiler, or after removal.

(b) STEAK AND CHOPS:

Cuts of meat with bones require longer cooking times at lower temperatures to reach the same internal doneness as cuts without bones. To prepare a well-done steak, trim the fat to reduce flare-up and the tendency to burn the outside.

(c) HAMBURGERS:

Chopped steak, etc. **MUST NOT BE TOO LEAN.** For fat flare and smoking action in char-broiling, hamburgers should have about 25% fat content.

Fat rendered out during broiling:

- (1) Helps to release the burger from the grates.
- (2) Helps the searing action that seals meat juices inside.
- (3) Enhances the char-broil flavor by flaring-up in the form of smoke and flame.

(d) THICKNESS:

During the broiling process, the hamburger contracts and becomes thicker and smaller in diameter. Pressing the hamburger out thin before broiling will compensate for the shrinkage. Broil a hamburger as you would broil a steak.

- (1) Be sure that the char-broiler has had adequate pre-heating time so that the hamburger does not stick to the broiler grate.
- (2) Place the hamburger on the grate and allow it to cook until release is attained.
- (3) Once the hamburger releases from the grate, turn it over and allow it to cook for 1 minute, then turn once a minute until the desired degree of doneness is attained.

(e) COOKING TOOLS:

Bakers Pride has designed a number of tools to help you operate more efficiently including a special spatula that is very effective for fish and hamburgers. Other tools are available. Contact the factory for full details

3. HELPFUL HINTS:

- (a) Do not press the juice out of the meat because that will cause a dry product.
- (b) Allow the meat to sit covered on a heated platter for 2 to 5 minutes after broiling before cutting. This will allow the juices to "settle" and the product will be more moist.
- (c) Do not use forks or other sharp objects which poke holes in the meat. Do not cut the meat as it cooks.
- (d) Thick pieces of meat require a longer broiling time with less flare-up. Reduce flare-up trimming excess fat for a longer broil time without burning.
- (e) Keep the unit clean. Food caught between the grates will not allow hot air to rise around the product. This will result in uneven heating and increase cook time.

4. MAINTENANCE:

(a) **SERVICE:**

Shut off the main gas supply before attempting any maintenance on the unit. If required, contact your Dealer, the Factory, or a local Service Company to obtain qualified maintenance and repairs.

(b) **CARE AND CLEANING OF TOP GRATES:**

The top grates should be cleaned using a stiff wire brush. If this is done daily, the accumulation of food and fat caught in the grates and work necessary to keep them clean will be reduced. Periodically, they should be turned over and brushed and then put back. In the event that an extra amount of fat is accumulated on the top, due to use of low heat, we recommend turning up the flame of this section for about an hour, which will burn off much of the fat and residue and the brushing operation will be easier. Under no circumstances should the grates be placed in a dishwasher. Soap, water, or any detergents should never be used on the cast iron grates.

(c) **GREASE COLLECTION:**

Your char-broiler is designed to bring grease into the front channel which in turn drains the grease into the grease collection pan in the lower section of the broiler. The pan in the lower section should be cleaned daily or more often if necessary. The channel should be cleaned periodically with a stiff brush or scraper.

(d) **CLEANING TOOLS:**

Several models of specially designed top grate brushes and grease drain scrapers are available from Bakers Pride. Contact Bakers Pride for more information.

5. AVERAGE PRODUCTION GUIDE:

Estimated Hourly Production

MODEL NUMBER		BROILING AREA	3 OZ. BURGERS	12 OZ. STEAKS
CH-4	XX-4	21" x 24"	600	120
CH-6	XX-6	31 1/2" x 24"	900	180
CH-8	XX-8	42" x 24"	1200	240
CH-10	XX-10	52 1/2" x 24"	1500	300
CH-12	XX-12	63" x 24"	1800	360
CH-14		73 1/2" x 24"	2100	420
CH-16		84" x 24"	2400	480

The table above gives estimated hourly production as a guide only. Actual production may vary depending on required doneness, thickness and weight of product.

III. TROUBLE SHOOTING GUIDE

CAUTION: Take extreme care to assure that, if a valve is opened, a flame is present. If a valve is left open without a flame, turn the valve off and wait at least five minutes before attempting to (re)light. Service should be performed only by a qualified gas technician.

1. BURNER FLAME ADJUSTMENT:

- (a) The burner flame should be as blue as possible. However, there will be traces of orange and/or yellow from particles in the air burning in the flame. Slight yellow tips at the flame ends are acceptable.
- (b) If the flame appears yellow, loosen the air-mixer cap hold down screw "A" (see figs. 2 and 3). Rotate the air mixer cap counter-clockwise to allow more air into the burner, until the flame turns blue. Tighten the screw.

2. PILOT FLAME ADJUSTMENT:

The pilot flame can be adjusted by turning the appropriate adjusting screw using a screwdriver or a 3/16 wrench (see fig. 2), counter-clockwise to increase, clockwise to decrease and close. The pilot flame should be about ½ inch long.

3. LACK OF HEAT:

Check to see if the pilot flames are on. If they are on but the burners do not light, or the burner flames look weak, then there is a possibility of a gas pressure loss to the broiler.

- (a) Check that the unit's main valve is fully open. Normally in the open position, the valve handle will be parallel to the piping. The valve should be located somewhere on the gas line feeding the char-broiler. If the handle is NOT parallel to the piping, the unit is not getting the gas supply required to operate properly. Turn the valve handle parallel to the gas supply line.
- (b) If there is a problem with the gas supply, it may be checked fairly easily. Turn off half of the burners or turn off all other gas appliances and see if the broiler flames increase. If there is an increase in the flame height then there is a problem with the gas supply. A problem with the gas supply requires immediate attention. **IMMEDIATELY** close all the burner valves (turn to the off position), including the char-broiler's main valve. Contact a qualified service agency or the public gas company.

The following should be checked:

- 1. The building's main pressure regulator.
- 2. The size of the broiler's gas supply line (if it is a new installation).
- 3. The broiler's pressure regulator.
- 4. The orifice size of each burner.

4. ONE BURNER FAILS TO LIGHT:

NOTE: Always make sure that grates, radiants and burners are cold before handling.

- (a) Check to see that the on/off valve to that burner is on.
- (b) Check to see if the pilot flame is lit. Each burner has its own pilot, which is located on the manifold along the front of the char-broiler (see fig. 2).

If the pilot is not lit, attempt to light it using a long taper. If it fails to light, turn off all the burners, allow to cool and then remove the top grate and the radiant over the burner. With a thin wire or pin, check that the hole is clear at the top of the pilot tube. Attempt to relight using a taper.

- (c) **If the pilot burner is lit**, close all the burner valves, allow to cool and then remove the top grate and the radiant over the burner, and check that the pilot flame is located over the first few holes in the burner. The pilot tube can be bent slightly to reposition the flame.

- (d) **If the pilot is lit, positioned correctly**, and has a proper flame, close all the burner valves , allow to cool and then remove the top grate and radiant over the burner.

Remove the burner by lifting the rear of the burner off the support pin, slide it towards the rear of the broiler, enough to clear the burner orifice (fig. 3 or 4).

Using a thin wire or pin, check to see that the orifice is clear, taking care not to enlarge the hole. Replace the burner, radiant and grate and attempt to light it again.

If the burner will not light, the burner valve could be defective. Contact your dealer, the factory or a local service company.

For additional information contact: Bakers Pride Oven Co., Inc. (914) 576-0200.

5. VALVE ASSEMBLY VIEWS:

(A = Cap Hold-Down Screw)

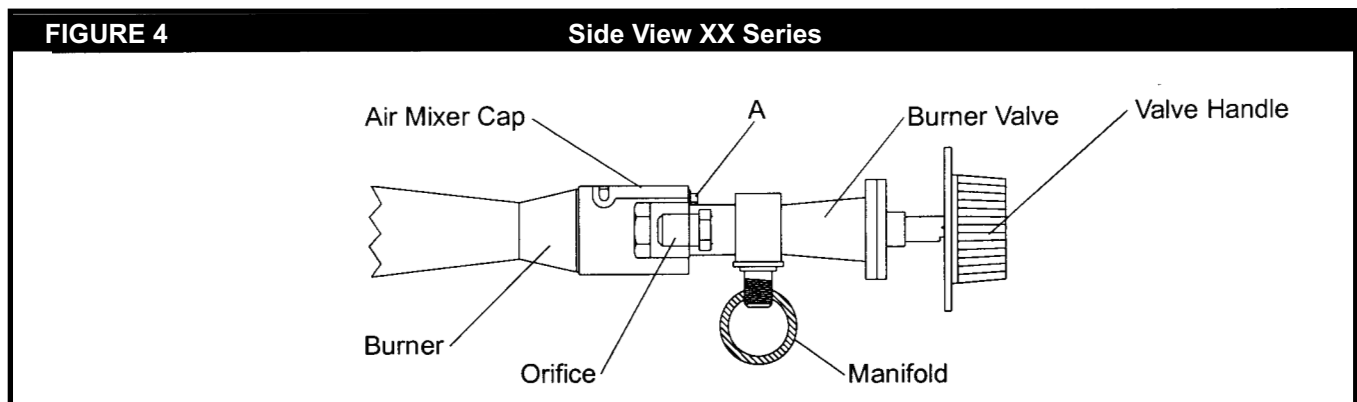
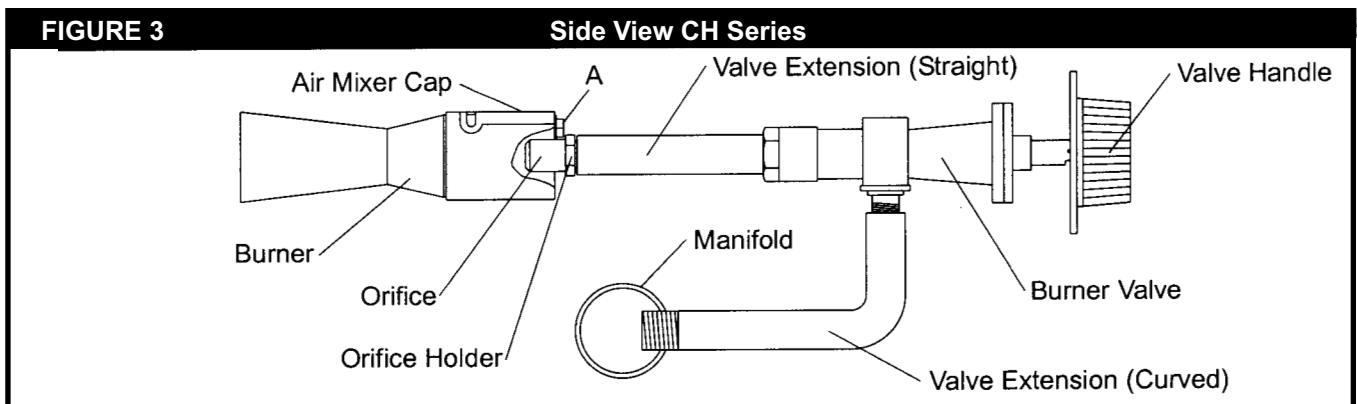
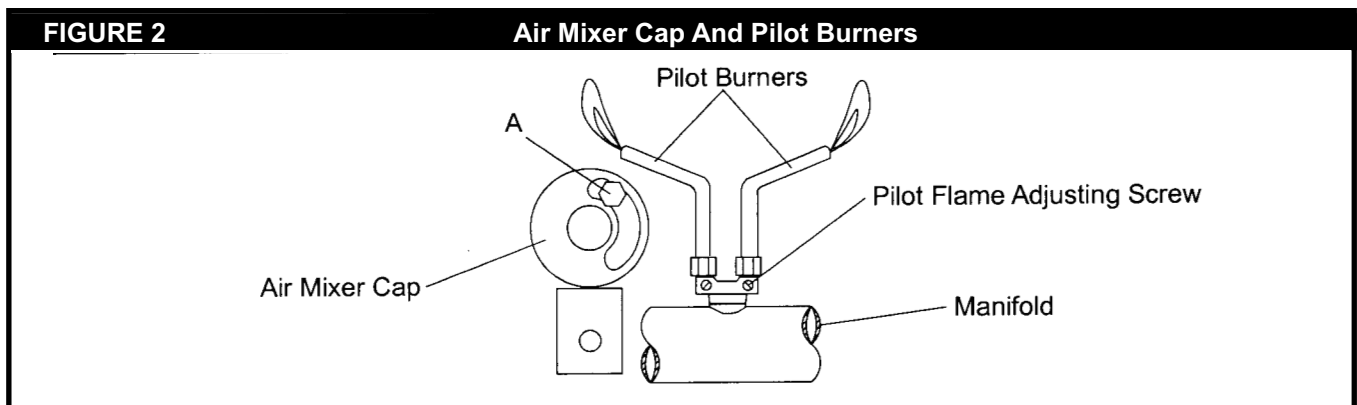

IV. PARTS LISTS & EXPLODED VIEWS

XX-4, 6, 8, 10, 12

Gas Char Broiler

30 Pine Street • New Rochelle • New York • 10801

914 / 576 - 0200

914 / 576 - 0605 fax

1 - 800 - 431 - 2745 US & Canada

www.bakerspride.com web address



Figure B

Burner / Accessories

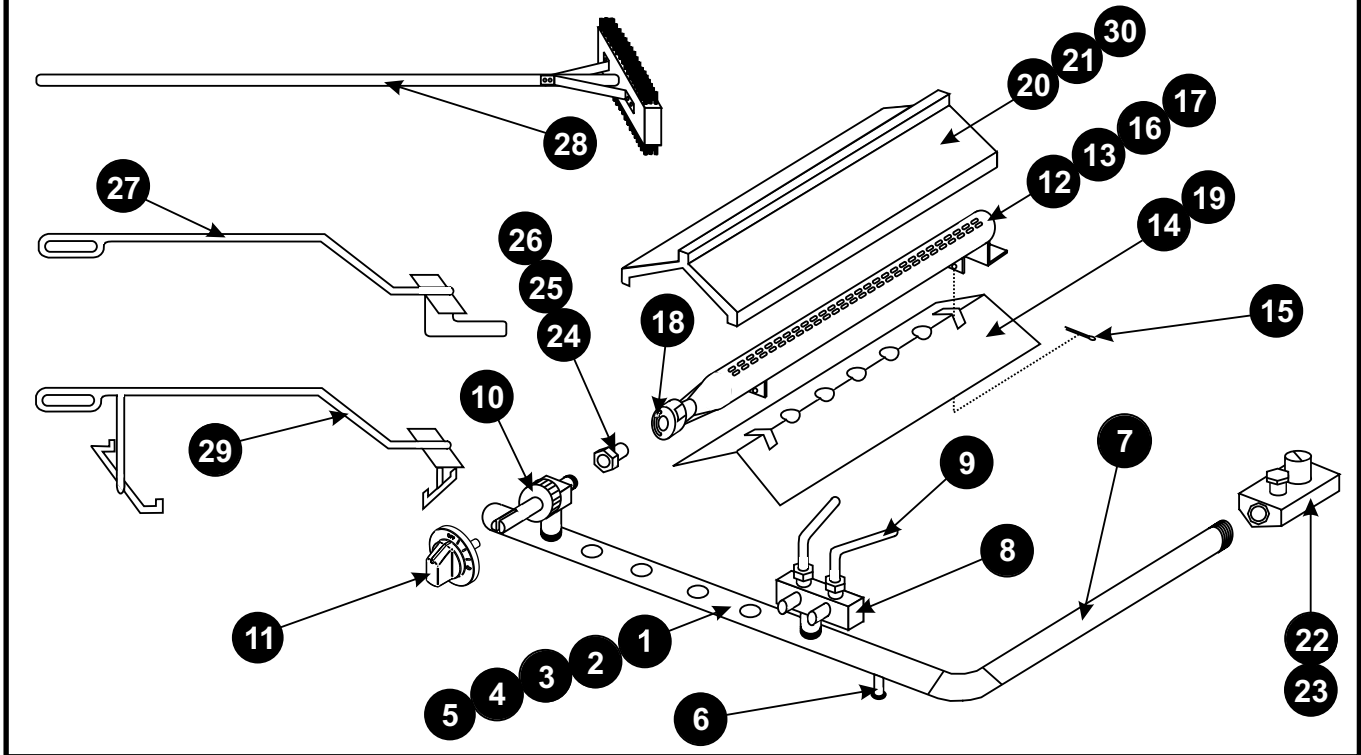

Item	Part #	Description	Item	Part #	Description
1	R1017X	Manifold Assy (XX-4)	16	L5027V	Burner Assy Complete, C.I. 24" (XX) O/S
2	R1018X	Manifold Assy (XX-6)	17	L5014V	Burner Only, C.I. 24" w/ Mixer Cap (XX) O/S
3	R1019X	Manifold Assy (XX-8)	18	R3022X	Air Mixer Cap w/Screw (C.I. Burner only)
4	R1020X	Manifold Assy (XX-10)	19	H1008X	Grease Guard Only (C.I. Burner)
5	R1133X	Manifold Assy (XX-12)	20	T1007A	Radiant Cast Iron (23") Optional (Shown)
6	N3068P	Pressure Tap Nozzle Assy	21	T1155T	Radiant S/S (23") Standard
7	N5217A	Gas Inlet Pipe (XX Series)	22	M1009X	Pressure Regulator, 3/4", 10" WC
8	R3020X	Valve, Pilot-Dual	23	M1008X	Pressure Regulator, 3/4", 5" WC
9	R3042X	Pilot Tubing, 7 3/8" (XX Series)	24	R3043X	Orifice Hood #47, Nat (XX)
10	R3032X	Valve, Burner (LML) w.o./Knob	25	R3044X	Orifice Hood #55, LP (XX)
11	S1416X	Knob, Gas Valve, On/Off (XX Series)	26	R3023X	Orifice Hood, Blank
12	L5019X	Burner Assy Complete, Tube 24" (XX)	27	T5041T	Grate Lifter (Cast Iron), 3' x 20"
13	L5013X	Burner Only, Tube 24" (XX)	28	T5104V	Twin Head Grate Brush
14	H1044X	Grease Guard Only (Tube Burner)	29	G5221U	Grate Lifter (Roll-A-Grate)
15	Q4008X	Cotter Pin, 1/8" x 2"	30	G1290U	Bottom Grate Burner Shield (Glo-Stone Only)
Conversion Kit (LP to Nat)			Conversion Kit (Nat to LP)		
R3043X	Hood Orifice # 47, Nat. (XX-4 uses 4) (XX-6 uses 6) (XX-8 uses 8) (XX-10 uses 10) (XX-12 uses 12)		R3044X	Hood Orifice #55, L.P. (XX-4 uses 4) (XX-6 uses 6) (XX-8 uses 8) (XX-10 uses 10) (XX-12 uses 12)	
M1008X	Pressure Regulator, 3/4", 5" WC (Qty. 1)		M1009X	Pressure Regulator, 3/4", 10" WC (Qty. 1)	

Note: When ordering, ALWAYS specify Part #, Model #, Serial #, Voltage/Phase & type of Gas.

2/05

XX-4, 6, 8, 10, 12

Gas Char Broiler

30 Pine Street • New Rochelle • New York • 10801

914 / 576 - 0200

914 / 576 - 0605 fax

1 - 800 - 431 - 2745 US & Canada

www.bakerspride.com web address



Figure A

Exterior / Grates

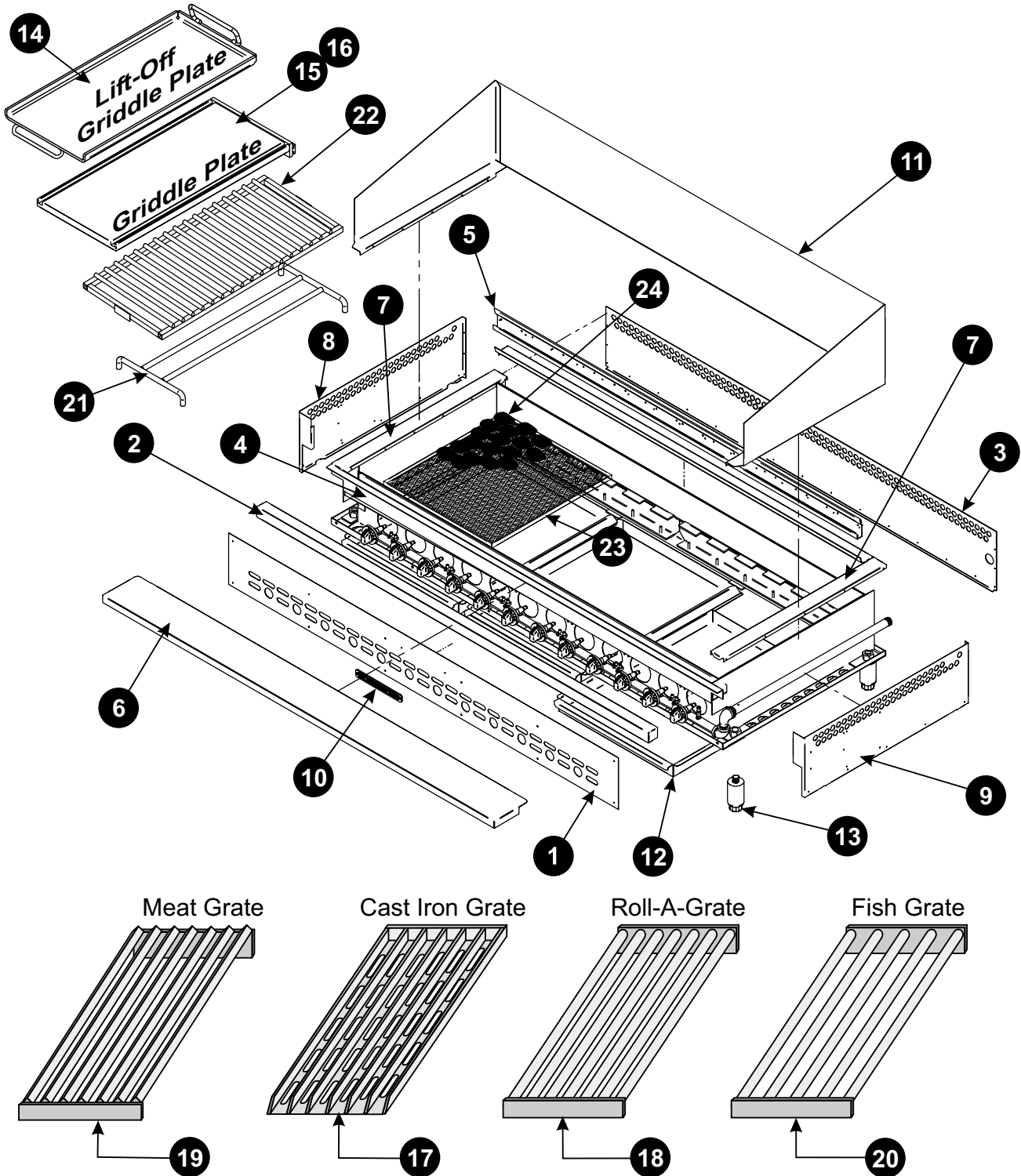

Note: When ordering, ALWAYS specify Part #, Model #, Serial #, Voltage/Phase & type of Gas.



30 Pine Street • New Rochelle • New York • 10801

914 / 576 - 0200

914 / 576 - 0605 fax

1 - 800 - 431 - 2745 US & Canada

www.bakerspride.com web address

XX-4, 6, 8, 10, 12

Gas Char Broiler

Item	Part #	Description	Item	Part #	Description
Exterior / Grates					
1	G1013X	Control Panel (XX-4)	11	G1081X	Splash Guard, S/S (XX-4) Optional
	G1014X	Control Panel (XX-6)		G1082X	Splash Guard, S/S (XX-6) Optional
	G1015X	Control Panel (XX-8)		G1083X	Splash Guard, S/S (XX-8) Optional
	G1016X	Control Panel (XX-10)		G1084X	Splash Guard, S/S (XX-10) Optional
	G1249K	Control Panel (XX-12)		G1237U	Splash Guard, S/S (XX-12) Optional
2	G1007X	Top Front Trim (XX-4)	12	T3033T	Grease Pan (XX-4 & 12) 20 3/8", 1 used
	G1008X	Top Front Trim (XX-6)		T3034T	Grease Pan (XX-6 & XX-10) 30 7/8", 1 used
	G1009X	Top Front Trim (XX-8)		T3035T	Grease Pan (XX-8) 19 5/8", 2 used or (XX-12) 1 used
	G1010X	Top Front Trim (XX-10)		T3036T	Grease Pan (XX-10) 19 1/2", 1 used
	G1248K	Top Front Trim (XX-12)	13	S1394Y	Leg, 4" Adjustable, Cylindrical 2" Dia. (Each)
3	G1122K	Outer Back (XX-4)		S1394X	Leg, 4" Adjustable, Cylindrical 2" Dia. (Set/4)
	G1123K	Outer Back (XX-6)		G1495A	Leg Adaptor (<i>Not Shown</i>)
	G1124K	Outer Back (XX-8)			(Needed for old style tapered, hex top legs only)
	G1125K	Outer Back (XX-10)	14	T1241U	Lift-Off Griddle 10 1/2"
	G1232K	Outer Back (XX-12)	15	T1251T	In-Line Griddle 10 1/2"
4	G1051K	Front Brace (XX-4)	16	T1020T	Griddle Plate 16"
	G1052K	Front Brace (XX-6)	17	T1216A	Grate, Top, Flat Cast Iron (4 1/2")
	G1053K	Front Brace (XX-8)		T1212A	Grate, Top, Flat Cast Iron (6")
	G1054K	Front Brace (XX-10)	18	T1199U	Roll-A-Grate (4 1/2")
	G1245K	Front Brace (XX-12)		T1198U	Roll-A-Grate (6")
5	G1021X	1st/2nd Level Assy (XX-4)	19	T1217U	Grate, Meat (4 1/2")
	G1022X	1st/2nd Level Assy (XX-6)		T1210U	Grate, Meat (6")
	G1023X	1st/2nd Level Assy (XX-8)	20	T1230T	Grate, Fish (4 1/2")
	G1024X	1st/2nd Level Assy (XX-10)		T1229T	Grate, Fish (6")
	G1247K	1st/2nd Level Assy (XX-12)		T1166T	Grate, Fish (10 1/2")
6	G1070X	Work Deck, S/S (XX-4) Optional	21	T1183T	Grate, Fajita, Bottom
	G1078X	Work Deck, S/S (XX-6) Optional	22	T1185S	Grate, Fajita, Top
	G1079X	Work Deck, S/S (XX-8) Optional	23	★T1243U	Long Bottom Grate 31 9/16 (Glo-Stone Option Only)
	G1080X	Work Deck, S/S (XX-10) Optional		★T1242U	Short Bottom Grate 21 1/16 (Glo-Stone Option Only)
	G1296K	Work Deck, S/S (XX-12) Optional	24	★T1250A	Briquettes, Ceramic 9.5 lb Bag (Glo-Stone Option Only)
7	G1011X	Top Side Trim, SS, Left		★ NOTE:	
	G1012X	Top Side Trim, SS, Right		XX-4:	(1) T1242U, (2) T1250A
8	G1126X	Outer Side, Left (XX)		XX-6:	(1) T1243U, (3) T1250A
9	G1127K	Outer Side, Right (XX)		XX-8:	(2) T1242U, (4) T1250A
10	U1044X	Name Plate, 8", Bakers Pride		XX-10:	(1) T1242U, (1) T1243U, (5) T1250A
				XX-12:	(2) T1243U, (6) T1250A



30 Pine Street • New Rochelle • New York • 10801

914 / 576 - 0200

914 / 576 - 0605 fax

1 - 800 - 431 - 2745 US & Canada

www.bakerspride.com web address

CH-6, 8, 10, 12, 14

Gas Char Broiler

Item	Part #	Description	Item	Part #	Description
Parts List (See Figure A)					
1	T1006A	Top Grate 5 1/4' Wide	40	T3120X	Grease Pan, set/2 (CH-10)
2	T1217U	Grate, Meat (4 1/2")	41	T3121X	Grease Pan, set/2 (CH-12)
3	T1210U	Grate, Meat (6")	42	T3122X	Grease Pan, set/3 (CH-14)
4	T1216A	Grate, Top, Flat Cast Iron (4 1/2")	43	T3123X	Grease Pan, set/3 (CH-16)
5	T1212A	Grate, Top, Flat Cast Iron (6")	44	T3124X	Grease Pan, set/3 (CH-18)
6	T1199U	Roll-A-Grate (4 1/2")	45	T3125X	Grease Pan, set/4 (CH-20)
7	T1198U	Roll-A-Grate (6")	46	T3126X	Grease Pan, set/4 (CH-22)
8	T1230T	Grate, Fish (4 1/2")	47	T3078V	S/S Heat Shield w/Handle (CH-4)
9	T1229T	Grate, Fish (6")	48	T3079V	S/S Heat Shield w/Handle (CH-6)
10	T1166T	Grate, Fish (10 1/2")	49	T3080V	S/S Heat Shield w/Handle (CH-8)
N/S	T1228T	Grate, Tango (6")	50	T3081X	S/S Heat Shield w/Handle set/2 (CH-10)
N/S	T1227T	Grate, Tango (9")	51	T3082X	S/S Heat Shield w/Handle set/2 (CH-12)
11	T1020T	Griddle Plate (Optional)	52	T3083X	S/S Heat Shield w/Handle set/3 (CH-14)
12	T1007A	Radiant Deflector (Cast Iron)	53	T3084X	S/S Heat Shield w/Handle set/3 (CH-16)
13	T1155T	Radiant Deflector (Stainless Steel)	54	T3085X	S/S Heat Shield w/Handle set/3 (CH-18)
14	L5019X	Tube Burner Assy w/Grease Guard	55	T3086X	S/S Heat Shield w/Handle set/4 (CH-20)
15	L5013X	Tube Burner w/Air Mixer Cap	56	T3087X	S/S Heat Shield w/Handle set/4 (CH-22)
16	L5027V	Cast Iron Burner w/Grease Guard O/S	57	S1134X	Heat Shield Handle w/Hardware
17	L5014V	Cast Iron Burner w/Air Mixer Cap O/S	58	S1022X	4" Caster w/o Lock (each)
18	R3022X	Air Mixer Cap w/Screw (for O/S CI Burner)	59	S1023X	4" Caster w/Lock (each)
19	H1044K	Burner Grease Guard	60	S1090T	Front Leg Left w/caster 12" (each)
20	H1008K	Burner Grease Guard (for O/S CI Burner)	61	S1091T	Front Leg Cen. & Right w/caster 12" (each)
21	Q4008A	Cotter Pin	62	S1089T	Rear Leg w/caster 12" (each)
22	R3032X	Gas Valve (without knob)	63	S1018T	Leg 12" (each)
23	S1094X	Gas Valve Knob	64	S1115Y	Legs w/Casters set/4 (12")
24	N1006X	Curved Valve Extension	65	S1116Y	Legs w/Casters set/6 (12")
25	N1005X	3 5/8" Straight Valve Extension	66	S1017Y	12" Legs set/6
26	R3025X	Orifice Holder (Only)	67	S1018Y	12" Legs set/4
27	R3028X	Orifice Spud #49 Drill (.073") Nat.	68	T3045T	Grease Drawer w/Handle Left (All)
28	R3031X	Orifice Spud #56 Drill (.0465") LP	69	T3046T	Grease Drawer w/Handle Right (CH14-22)
29	R3026X	Orifice Spud - Special Drill Size (Specify)	70	S1016X	Grease Drawer Handle w/Screws
30	M1008X	Pressure Regulator 3/4" Nat 5"WC (CH 6, 8)	71	G5221U	Grate Lifter (Roll-A-Grate)
31	M1009X	Pressure Regulator 3/4" LP 10"WC (CH 6, 8)	72	T5041T	Grate Lifter (Cast Iron) 3' x 20"
32	M1066X	Pressure Regulator 1" Nat 5"WC (CH 10, 12, 14)	N/S	T1190A	Richlite CH-6 (Optional)
33	M1067X	Pressure Regulator 1" LP 10"WC (CH 10, 12, 14)	N/S	T1189A	Richlite CH-8 (Optional)
34	R3021X	Adjustable Pilot Valve (Single)	N/S	T1174A	Richlite CH-10 (Optional)
35	R3020X	Adjustable Pilot Valve (Double)	N/S	T1122A	Richlite CH-12 (Optional)
36	R3034X	S/S Pilot Tube 6" w/nut & ferrule	N/S	T1123A	Richlite CH-14 (Optional)
37	T3015T	Grease Pan (CH-4)	N/S	H1530S	Splash Sides (Set/2)
38	T3016T	Grease Pan (CH-6)	N/S	T1251T	Griddle Plate 10 1/2" (In Line)
39	T3018T	Grease Pan (CH-8)	N/S	T1252T	Griddle Plate 18" (In Line)
Conversion Kit (LP to Nat)			Conversion Kit (Nat to LP)		
R3028X	Orifice Spud #49 Drill (.073") Nat. (CH-6 uses 6, CH-8 uses 8, CH-10 uses 10, CH-12 uses 12, CH-14 uses 14)		R3031X	Orifice Spud #56 Drill (.0465") LP (CH-6 uses 6, CH-8 uses 8, CH-10 uses 10, CH-12 uses 12, CH-14 uses 14)	
M1008X	Pressure Regulator 3/4" Nat 5"WC (CH 6, 8)		M1009X	Pressure Regulator 3/4" LP 10"WC (CH 6, 8)	
M1066X	Pressure Regulator 1" Nat 5"WC (CH 10, 12, 14)		M1067X	Pressure Regulator 1" LP 10"WC (CH 10, 12, 14)	



V. BAKERS PRIDE LIMITED WARRANTY

30 Pine Street New Rochelle, New York 10801
914 / 576 - 0200 • US & Canada: 1 - 800 - 431 - 2745 • fax 914 / 576 - 0605

- WHAT IS COVERED** This warranty covers defects in material and workmanship under normal use, and applies only to the original purchaser providing that:
- ◆ The equipment has not been accidentally or intentionally damaged, altered or misused;
 - ◆ The equipment is properly installed, adjusted, operated and maintained in accordance with National and local codes, and in accordance with the installation instruction provided with the product;
 - ◆ The serial number rating plate affixed to the equipment has not been defaced or removed.
- WHO IS COVERED** This warranty is extended to the original purchaser and applies only to equipment purchased for use in the U.S.A.
- COVERAGE PERIOD** Cyclone Convection Ovens: BCO Models: One (1) Year limited parts and labor; (1) Year limited door warranty.
GDCC Models: Two (2) Year limited parts and labor; (2) Year limited door warranty.
CO11 Models: Two (2) Year limited parts and labor; (5) Year limited door warranty.
All Other Products: One (1) Year limited parts and labor. Warranty period begins the date of dealer invoice to customer or ninety (90) days after shipment date from BAKERS PRIDE - whichever comes first.
- WARRANTY COVERAGE** This warranty covers on-site labor, parts and reasonable travel time and travel expenses of the authorized service representative up to (100) miles, round trip, and (2) hours travel time. The purchaser, however, shall be responsible for all expenses related to travel, including time, mileage and shipping expenses on smaller counter models that may be carried into a Factory Authorized Service Center, including the following models: PX-14, PX-16, P18, P22S, P24S, PD-4, PDC, WS Series and BK-18.
- EXCEPTIONS** All removable parts in BAKERS PRIDE Char-broilers, including but not limited to: Burners, Grates, Radiants, Stones and Valves, are covered for a period of SIX MONTHS.
All Ceramic Baking Decks are covered for a period of THREE MONTHS. The installation of these replacement decks is the responsibility of the purchaser.
The extended Cyclone door warranty years 3 through 5 is a parts only warranty and does not include labor, travel, mileage or any other charges.
- EXCLUSIONS**
- ◆ Negligence or acts of God,
 - ◆ Thermostat calibrations after (30) days from equipment installation date,
 - ◆ Air and Gas adjustments,
 - ◆ Light bulbs,
 - ◆ Glass doors and door adjustments,
 - ◆ Fuses,
 - ◆ Char-broiler work decks and cutting boards,
 - ◆ Tightening of conveyor chains,
 - ◆ Adjustments to burner flames and cleaning of pilot burners,
 - ◆ Tightening of screws or fasteners,
 - ◆ Failures caused by erratic voltages or gas supplies,
 - ◆ Unauthorized repair by anyone other than a BAKERS PRIDE Factory Authorized Service Center,
 - ◆ Damage in shipment,
 - ◆ Alteration, misuse or improper installation,
 - ◆ Thermostats and safety valves with broken capillary tubes,
 - ◆ Accessories — spatulas, forks, steak turners, grate lifters, oven brushes, scrapers, peels, etc.,
 - ◆ Freight — other than normal UPS charges,
 - ◆ Ordinary wear and tear.
- INSTALLATION** Leveling and installation of decks, as well as proper installation and check out of all new equipment — per appropriate installation and use materials — is the responsibility of the dealer or installer, not the manufacturer.
- REPLACEMENT PARTS** BAKERS PRIDE genuine Factory OEM parts receive a (90) day materials warranty effective from the date of installation by a BAKERS PRIDE Factory Authorized Service Center.

This Warranty is in lieu of all other warranties, expressed or implied, and all other obligations or liabilities on the manufacturers part. BAKERS PRIDE shall in no event be liable for any special, indirect or consequential damages, or in any event for damages in excess of the purchase price of the unit. The repair or replacement of proven defective parts shall constitute a fulfillment of all obligations under the terms of this warranty.

Form #U4177A 3/04