



INSTALLATION AND OPERATING INSTRUCTIONS GAS CONVECTION OVEN

Model: CO11-G

**INTENDED FOR OTHER THAN HOUSEHOLD USE
RETAIN THIS MANUAL FOR FUTURE REFERENCE
OVEN MUST BE KEPT CLEAR OF COMBUSTIBLES AT ALL TIMES**

IMPORTANT INSTRUCTIONS

After the gas supply has been connected to your unit, it is extremely important to check piping for possible leaks. To do this, use soap and water solution or solutions which are expressly made for this purpose.

DO NOT USE matches, candles, flames, or other sources of ignition since these methods are extremely dangerous. Post in a prominent location instructions to be followed in the event you smell gas. Obtain these instructions from your local gas supplier.



FOR YOUR SAFETY: *Do not store or use gasoline or other flammable vapors and liquids in the vicinity of this or any other appliance.*



WARNING: *Improper installation, adjustment, alteration, service or maintenance can cause property damage, injury or death. Read the Installation, Operating and Maintenance Instructions thoroughly before installing or servicing this equipment.*



Initial heating of oven may generate smoke or fumes and must be done in a well-ventilated area. Overexposure to smoke or fumes may cause nausea or dizziness.

Note: Only *Pizza* or *Bread* can have direct contact with ceramic decks. All other food products must be placed in a pan or container to avoid direct contact with ceramic decks.

This equipment has been engineered to provide you with year round dependable service when used according to the instructions in this manual and standard commercial kitchen practices.



P/N U4151A 05/04

BAKERS PRIDE OVEN CO., INC.

30 Pine Street
New Rochelle, NY 10801

+1 (914) 576-0200 Phone
+1 (914) 576-0605 Fax

(800) 431-2745 US & Canada
www.bakerspride.com Web Address
info@bakerspride.com e-mail Address

TABLE OF CONTENTS

I. INSTALLATION INSTRUCTIONS

<u>SECTION</u>	<u>ITEM</u>	<u>PAGE</u>
A	Receiving	3
B	Set-Up Mounting	3
C	Installation with Casters (Optional)	4
D	Location and Minimum Clearances	4
E	Gas Connection	4
F	Electrical Connection	5
G	Flue Connections-Ventilation	5
H	Burner Operation	6
I	System Check: Rotary Control	6

II. OPERATING INSTRUCTIONS

1	General Instructions	6
2	System Operation Sequence	7
	A) Cook Only	7
	B) Timed Cooking	7
	C) Cook & Hold	7
	D) Steam Injection	7
	E) Oven Cool Down	7
3	Cleaning	8
4	Servicing	8
5	Illustrations	8
6	Electrical Schematic - Rotary Control	10
7	Wiring Diagram - Rotary Control	11
8	Wiring Diagram - Programmable Control	12
9	Replaceable Parts List	13
10	Warranty	16

NOTE: For units with programmable controls a C&H-3 Plus™ Controller Manual is shipped under separate cover.

INSTALLATION INSTRUCTIONS

A. RECEIVING:

Read the notice on the outside carton regarding damage in transit. Damage discovered after opening the carton is "CONCEALED DAMAGE". Carrier must be notified immediately to send an inspector and to furnish forms for claims against the carrier.

When the oven arrives, it should consist of:

A crate or carton containing your new oven (two for a stacked unit).

A carton containing four 30" legs with mounting hardware (A set of four 6" legs is supplied for Stacked installations).

A carton containing a Flue Adapter and/or an optional Draft Hood for Direct Venting (Not available for European Community Countries)

B. SET UP/ MOUNTING:

NOTE: This appliance must be installed by competent person in accordance with the rules in force.

In the U.K. Corgi registered installers (including the regions of British Gas) undertake to work to safe and satisfactory standards. This appliance must be installed in accordance with the current Gas Safety (Installation and Use) Regulations and the relevant Building Regulations/IEE Regulations. Detailed recommendations are contained in the British Standard Codes Of Practice B.S. 6172, B.S. 5440:Part2 and B.S. 6891.

Your oven will be packed sitting on its bottom. The skid may be left under the oven for convenience in further handling. Unpack carefully, avoiding damage to the Stainless Steel front and/or trim. If concealed damage is found, follow the instructions detailed in Section A (Receiving). Keep the area around the ovens free and clear of combustible materials. Do not store any materials on top of or under any oven. The provision of adequate air supply to your oven for ventilation and proper gas combustion is essential. As a minimum, observe the clearances detailed in Section D (Location). Provide adequate ventilation and make up air in accordance with local codes. Servicing your oven is done through the front control panel and right side access cover. Assure that these areas are kept unobstructed for easy access.

For a single unit:

- (1) Tilt Oven over onto left hand side, and attach two 30" legs on the right hand side with three 1/2" bolts and washers. Tighten firmly.
- (2) Using proper lifting equipment lift up the left hand side and attach two 30" legs on the left hand side the same way.

For a stack of two ovens:

- (1) Tilt lower unit over onto the left hand side, attach two mounting plates to the right hand underside and screw 6" legs into the center holes.
- (2) Using proper lifting equipment lift up the left hand side and attach the mounting plates and 6" legs as in (Step1).
- (3) Using the lifting equipment, raise the top oven to proper height and slide on top of the bottom oven. Line up sides and front of both ovens and fasten to each other with stacking brackets.

All legs for the CO11-G 1 and CO11-G2 as well as the base cabinet have a leveling adjustment. Start with adjustment screwed all the way in. With a spirit level placed on an oven rack, check and level side to side first and then front to back.

Fit the Standard Flue Diverter supplied (Figure 1) into the hole in the top of the oven (for under ventilation hood installation) and secure with screws. For direct venting. The Flue Adapter and the Draft Hood must be placed into the hole on top of the oven(Figure 2).

To assemble an open rack stand: Refer to fig.3

- (1) Loosen 12 bolts(attaching 30" legs) slightly.
- (2) Remove 4 inner bolts, 1 from each of the four legs. Place top right angle and top left angle underneath and tighten these 4 bolts.
- (3) Insert Open Rack Shelf and tighten into place with eight 3/8-16 screws, washers and nuts.

- (4) Position 'Rack Supports' and tighten in place using 4 each of Flat washers and 5/16-18 Hex Nuts.

To assemble over a Base Cabinet:

- (1) Tilt cabinet over onto the left hand side. Attach two mounting plates to the right underside and screw 6" legs into the center holes.
- (2) Lift up left hand side of the base cabinet and attach the mounting plates and 6" legs on the underside and screw 6" legs into center holes.
- (3) Using the lifting equipment, raise the top oven to proper height and slide on top of the base cabinet. Line up sides and front and fasten to each other with stacking brackets.

C. INSTALLATION WITH CASTERS (OPTIONAL):

Four casters (two with wheel brakes) and the mounting hardware are packed and included in the shipment if ordered.

Install casters with wheel brakes on the front of the unit.

Installation of the unit should be made with a connector that complies with the latest edition of the Standard for Connectors for Movable Gas Appliances ANSI Z21.69, in the USA (CAN CGA-6.16 in Canada) and a quick disconnect device that complies with the latest edition of the standard for quick disconnect devices for use with gas fuel ANSI Z21A.1 in the USA (CAN 1-6.7 in Canada.) Adequate means must be provided to limit the movement of the appliance without depending on the connector and any quick disconnect device or its associated piping to limit the appliance movement.

The restraint should be attached to the rear legs of the oven on which casters are mounted. If disconnection of the restraint is necessary, the restraint should be reconnected after the appliance has been returned to its originally installed position.

D. LOCATION AND MINIMUM CLEARANCES:

Move the oven to its final location keeping the minimum clearance from the back of the oven to the wall. This clearance is necessary for safe operation and to provide proper air flow to the burner chamber.

MINIMUM CLEARANCES FROM COMBUSTIBLE AND NON-COMBUSTIBLE CONSTRUCTION		
	Under Ventilation Hood	Direct Venting
RIGHT WALL	1"	1"
LEFT WALL	1"	3"
REAR WALL	3"	3"

SUITABLE FOR INSTALLATION ON COMBUSTIBLE FLOOR WHEN INSTALLED WITH LEGS OR CASTERS PROVIDED.

CAUTION: DO NOT SET THE OVEN WITH ITS BACK FLAT AGAINST THE WALL. IT WILL NOT OPERATE PROPERLY UNLESS THERE IS AT LEAST THREE INCHES BREATHING SPACE BEHIND THE OVEN.

E. GAS CONNECTIONS:

The ovens should not be installed on the same gas line with space heaters, boilers or other gas equipment with high intermittent demand.

The installation of this oven must conform with the latest local codes or *National Fuel Gas Code. ANSI Z223.1, Natural Gas Installation Code. CAN/CGA-BJ49.1. or the Propane Installation Code. CAN/CGA-BJ49.2*

The appliance must be isolated from the gas supply piping system by closing it's manual shut-off valve during any pressure testing of the gas supply piping system at test pressures equal to or less than ½ psi (3.45kPa). The appliance and its shut-off valve must be disconnected from the gas supply piping system during any pressure testing of that system at test pressures in excess of ½ psig (3.45kPa).

Use a pipe joint compound that is resistant to the action of liquefied petroleum gases when making gas Connections. For Propane gas, use at least 1/2" (13 mm) pipe or tubing with a 5/8" (16 mm) inside diameter. For Natural gas, use 3/4" (19 mm) pipe.

The gas pressure regulator is part of the combination valve and is adjusted to yield a pressure of 3.5" water column (9mbar) for Natural Gas. If the oven is ordered for use on Propane Gas or Butane the pressure regulator in the combination valve is preset at the factory to yield a pressure of 10" water column (25 mbar).

Gas supply pressure in the European Community countries should be as below:

Gas Type	Supply Pressure
G20	20 mbar
G25	25 mbar
G20/25	20/25 mbar
G30	30 or 50 mbar depending on country
G31	30, 37, or 50 mbar depending on country

A separate shut-off valve for each oven must be provided. It should be as close as possible to the place where the gas line goes into the oven. It must be located such that it is easily accessible. When stacking with another oven, two shut-off valves, one for each of the two ovens, must be provided.

After the Gas Supply has been connected, it is extremely important to check all the piping for leaks. Use a soap and water solution or a product expressly made for this purpose. Do not use Matches, Candles or a Flame etc to check leaks since these methods are extremely dangerous.

F. ELECTRICAL CONNECTION:

The oven when installed must be electrically grounded in accordance with local codes/and/or the latest edition of the National Electrical Code ANSI/NFPA No. 70 in the USA (Canadian Electrical Code CSA Standard C22.1, Part 1 in Canada).

In Europe, the appliance must be connected by an earthing cable to all other units in the complete installation and thence to an independent earth connection in compliance with EN 60335-1 and/or local codes.

The electric motor, all the related switches, interior lights and the timer/buzzer, are all connected through the 6ft (1829 mm) power supply cord located at the rear of the oven. The supply cord must be plugged into a properly grounded three-prong receptacle. **DO NOT CUT OR REMOVE THE GROUNDING PRONG FROM THE PLUG.**

Normal factory connections are made for 115 volts AC., 60 Hz. Service in USA and Canada or 230Volts AC, 50 Hz service in European Community Countries. Other voltages can be supplied upon request. Electrical characteristics of this unit can be found on the rating plate located on the right side of the unit.

This unit is provided with a permanently lubricated electric motor. A wiring diagram may be found on the back of the service panel on the right hand side and in this manual.

G. FLUE CONNECTION - VENTILATION:

(a) INSTALLATION UNDER VENTILATION HOOD (STANDARD):

If the oven is not vented directly and is installed under a ventilation hood, use the flue diverter (Fig. 1) supplied. Local inspectors and ventilation specialist should be consulted so that the design and the installation of the hood conforms to local/municipal codes.

In U.K. ventilation requirements as detailed in B.S. 5440 should be followed.

(b) OPTIONAL DIRECT VENTING-NOT AVAILABLE FOR EUROPEAN COMMUNITY COUNTRIES:

If direct venting, a flue adapter and a draft hood (fig.2) are required to be installed. These prevent the flue gases leaving the oven from being affected by the air pressure changes on the outside of the flue stack

extending out of the building. The flue pipe from the draft hood must not run downwards at any point from the oven to the final outlet. It should always slant slightly upwards. For best results it should rise straight up

NOTE: DO NOT PUT A DAMPER IN THE FLUE AND DO NOT CONNECT A BLOWER DIRECTLY TO THE FLUE.

If the flue runs directly to the free air outside the building, use a wind deflector or a UL listed vent cap at the end of the pipe. Termination of the vent must be at least two feet above the highest part of the roof within ten feet. REF: AGA CATALOG NO. XH0474.

H. BURNER OPERATION:

The oven burner flame should always have a blue appearance. This indicates a good mixture of air and gas. When using LP gas the flame will have a blue yellow appearance. There may be intermittent yellow-orange flame noticed. This is caused by dust particles burning in the flame.

SYSTEM CHECK: ROTARY CONTROL:

- 1) Open the oven door.
- 2) Turn Selector Switch to 'Hi'. The indicator light near Selector Switch and oven light will illuminate.
- 3) Close the door. Oven lights will go off and fan will run. Make sure fan is rotating clockwise looking from front.
- 4) Press Oven Light switch. Oven light will go on and will go off as switch is released.
- 5) Turn Gas Cock Dial to 'ON' position.(only for USA & Canada)
- 6) Turn the thermostat knob. The indicator light near the thermostat will illuminate and the burners will come on.
- 7) Turn the Timer Knob and set a time of 2 minutes. At the end of 2 minutes, you should hear the buzzer. Turn the timer knob to '0' to reset.
- 8) Open the oven doors. Oven lights will go on, and burners and fan will go off.
- 9) Turn Selector switch to 'Cool Down' position. The fan will run to cool down the oven.
- 10) Turn Selector Switch to '0' position.
- 11) Close the oven doors.
- 12) Turn Gas Cock Dial to 'Off position.(only for USA & Canada)

NOTE: OVEN WILL START HEATING AS SOON AS THE SET TEMPERATURE IS HIGHER THAN THE OVEN TEMPERATURE, THE OVEN DOORS CLOSED AND THE SELECTOR SWITCH IS IN ANY POSITION EXCEPT '0'.

THERMOSTAT INDICATOR LIGHT GOES OUT WHEN OVEN REACHES SET TEMPERATURE AND COMES ON WHEN OVEN IS HEATING UP.

IN THE EVENT OF POWER FAILURE, THE OVEN WILL NOT OPERATE.

II. OPERATING INSTRUCTIONS

1. GENERAL INSTRUCTIONS:

- (a) This equipment has an Electronic Temperature Control and Electronic Hot Surface Direct Ignition System.
- (b) Due to the increased efficiency of this oven, the temperature of standard recipes may be reduced 50°F (30°C).
- (c) Always load each shelf evenly. Space pans away from each other and from sides and back of oven to allow maximum air flow between them.
- (d) Large tempered glass windows and interior lights allow visual checks on the product making it unnecessary to frequently open the doors. Products cook faster in a convection oven as compared to a conventional oven. Depending on the product and the type of pans used, time savings may run from 20% to as high as 50%.

2. OPERATION SEQUENCE-ROTARY CONTROL:

A. COOK ONLY-ROTARY CONTROL:

- (1) Close the oven doors.
- (2) Turn Selector Switch to 'HI' or 'LO' position. The indicator light near the Selector Switch will be illuminated.
- (3) Turn the thermostat knob to the desired cooking temperature.
- (4) Upon reaching the set temperature, the indicator light near the thermostat will go out.
- (5) Load the oven with product to be cooked.
- (6) Remove the product from the oven when done.

B. TIMED COOKING-ROTARY CONTROL:

- (1) Close the oven doors.
- (2) Turn Selector Switch to 'HI' or 'LO' position . The indicator light near the Selector Switch will be illuminated.
- (3) Turn the thermostat knob to the desired cooking temperature.
- (4) Upon reaching the set temperature, the indicator light near the thermostat will go out.
- (5) Load the oven with product to be cooked.
- (6) Turn the timer knob to the desired bake time and timer will start counting down.
- (7) When timer reaches zero, a buzzer will sound.
- (8) Turn the timer knob to '0' position.
- (9) Remove the product from the oven.

NOTE: TIMER DOES NOT CONTROL THE OVEN.

C. COOK & HOLD-ROTARY CONTROL:

- (1) Close the oven doors.
- (2) Turn Selector Switch to 'HI' or 'LO' position. The indicator light near the Selector Switch will be illuminated.
- (3) Turn the thermostat knob to the desired cooking temperature.
- (4) Upon reaching the set temperature, the indicator light near the thermostat will go out.
- (5) Load the oven with product to be cooked.
- (6) Turn the timer knob to the desired bake time and timer will start counting down.
- (7) When timer reaches zero, a buzzer will sound.
- (8) Turn the Timer knob to '0' position to reset.
- (9) Turn the thermostat knob to the desired hold temperature.
- (10) Remove the product from the oven when done.

D. OPTIONAL STEAM INJECTION-ROTARY CONTROL:

The solenoid valve for steam injection is mounted behind the service panel on the right hand side of the unit. The electronic timer is preset at the factory. A 1/4" copper tubing is provided on the Solenoid Valve for water hookup with a compression fitting. After the water hookup is made, make sure that there are no leaks. For steam injection, press the Steam switch momentarily.

NOTE: Do not use steam injection at temperatures below 275°F (135°C).

E. OVEN COOL DOWN-ROTARY CONTROL:

To cool down the oven to a lower desired temperature, follow the steps detailed below:

- (1) Open the oven doors.
- (2) Turn Selector Switch to 'oven cool down' position. Fan will now operate and cool down the oven.
- (3) When the oven has cooled down to the desired temperature, turn the selector switch to the 'O' position. Close oven doors.

3. CLEANING:

CLEAN ONLY WHEN OVEN IS COLD

- a) With porcelain enamel interiors, this oven is designed to be as maintenance free as possible. However for best results the oven should be cleaned regularly. Enameled interiors can be easily cleaned with oven cleaners. **KEEP CLEANING FLUIDS A WAY FROM ELECTRIC WIRES, LIGHT SOCKETS, SWITCHES AND CONTROL PANEL.**
- b) Baked-on splatter, oil, grease or discoloration on the stainless steel front or inside of the oven may be removed with stainless steel cleaner, or any other similar cleaning agent. **NOTE: ALWAYS RUB THE STAINLESS STEEL ALONG THE GRAINS.**
- c) To clean the blower wheel, remove and immerse in ammoniated water for 20 to 25 minutes. Then scrub it off with a small stiff brush. The same procedure can be followed for wire racks and rack supports.
To remove the blower wheel, loosen the set screws (2) on the hub of the blower wheel and tighten the 3/8" wheel puller bolt (supplied) in center of the hub (See Fig. 4).

4. SERVICING:

NOTE: This appliance must be serviced by an authorized service agent.

- a) Power supply to the unit must be disconnected before any service is performed.
- b) Most of the service on the unit can be performed from the front and/or control panel side.
- c) For proper servicing, access to the Control Panel side of the unit will be required.
- d) It will be necessary to have access to the back of the oven for service needs related to the gas supply, electric power supply and steam injection plumbing.
- e) A system wiring diagram is provided in this manual and on the back of the service panel on the right side of the oven.
- f) All servicing must be performed by a factory authorized technician only.
- g) For proper maintenance and repairs call the factory toll free (800-431-2745) for an authorized service agency in your area.

NOTE: The Ventilation System must be inspected at least every six months and maintained clean and free of obstructions.

5. ILLUSTRATIONS

Fig. 1

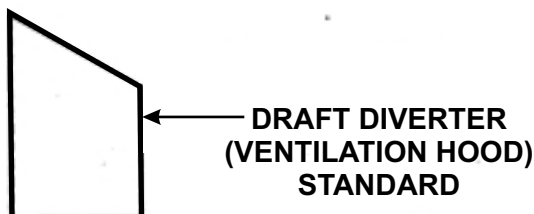
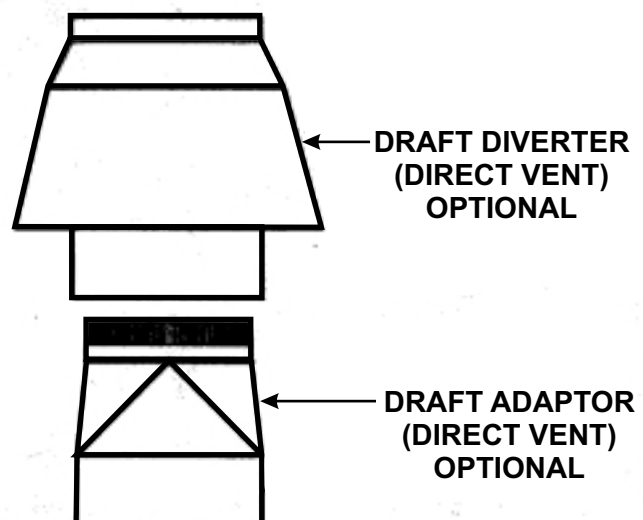
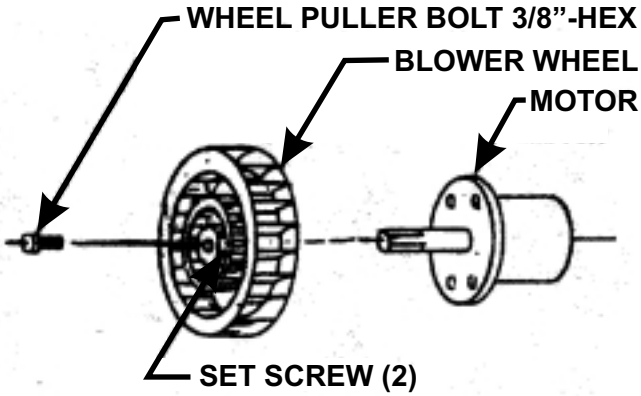

Fig. 2



5. ILLUSTRATIONS (CONTINUED)

Fig. 3



**Fig. 4 ASSEMBLY OF LEGS
(SHOWN WITH OPEN RACK STAND)**

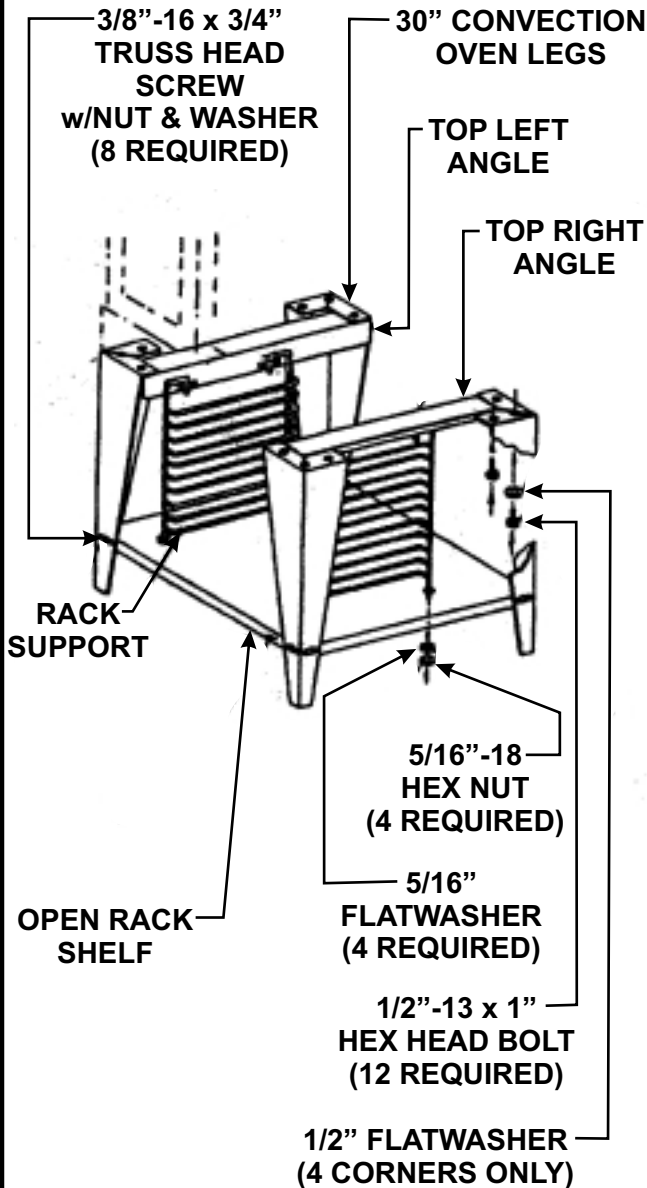
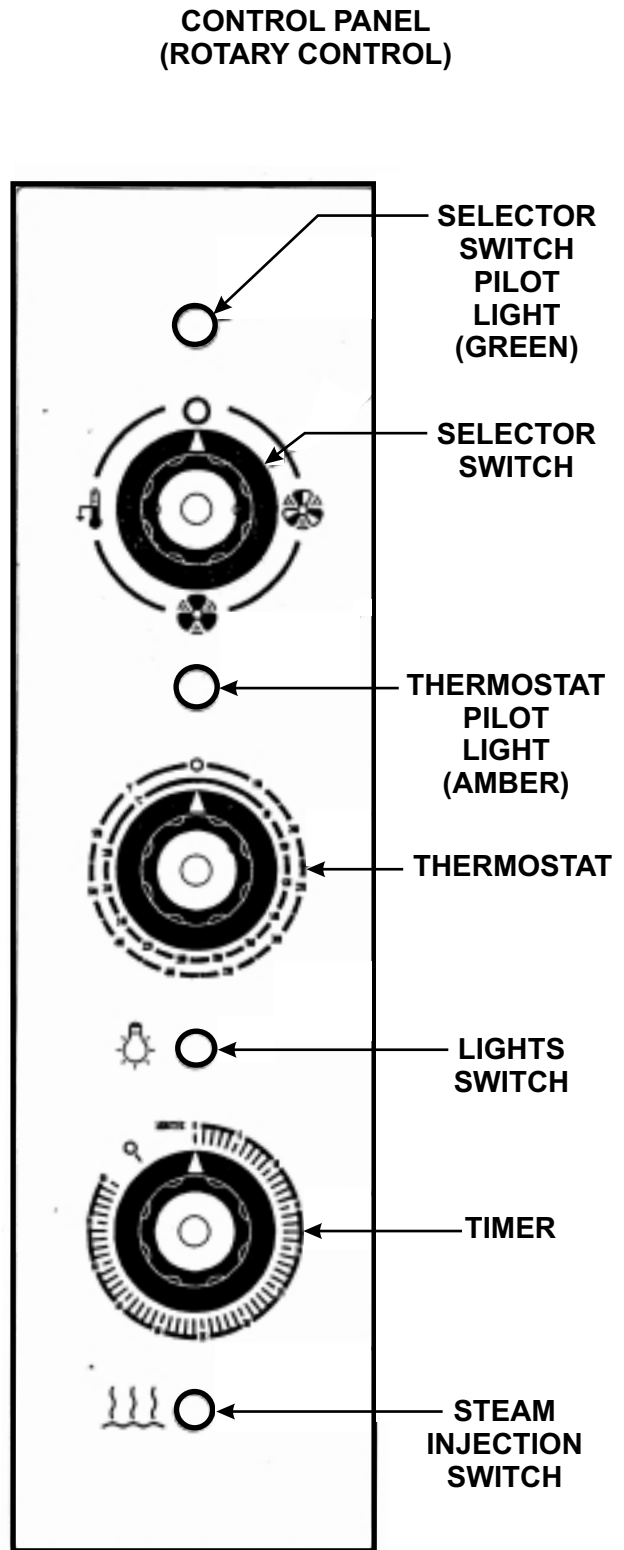
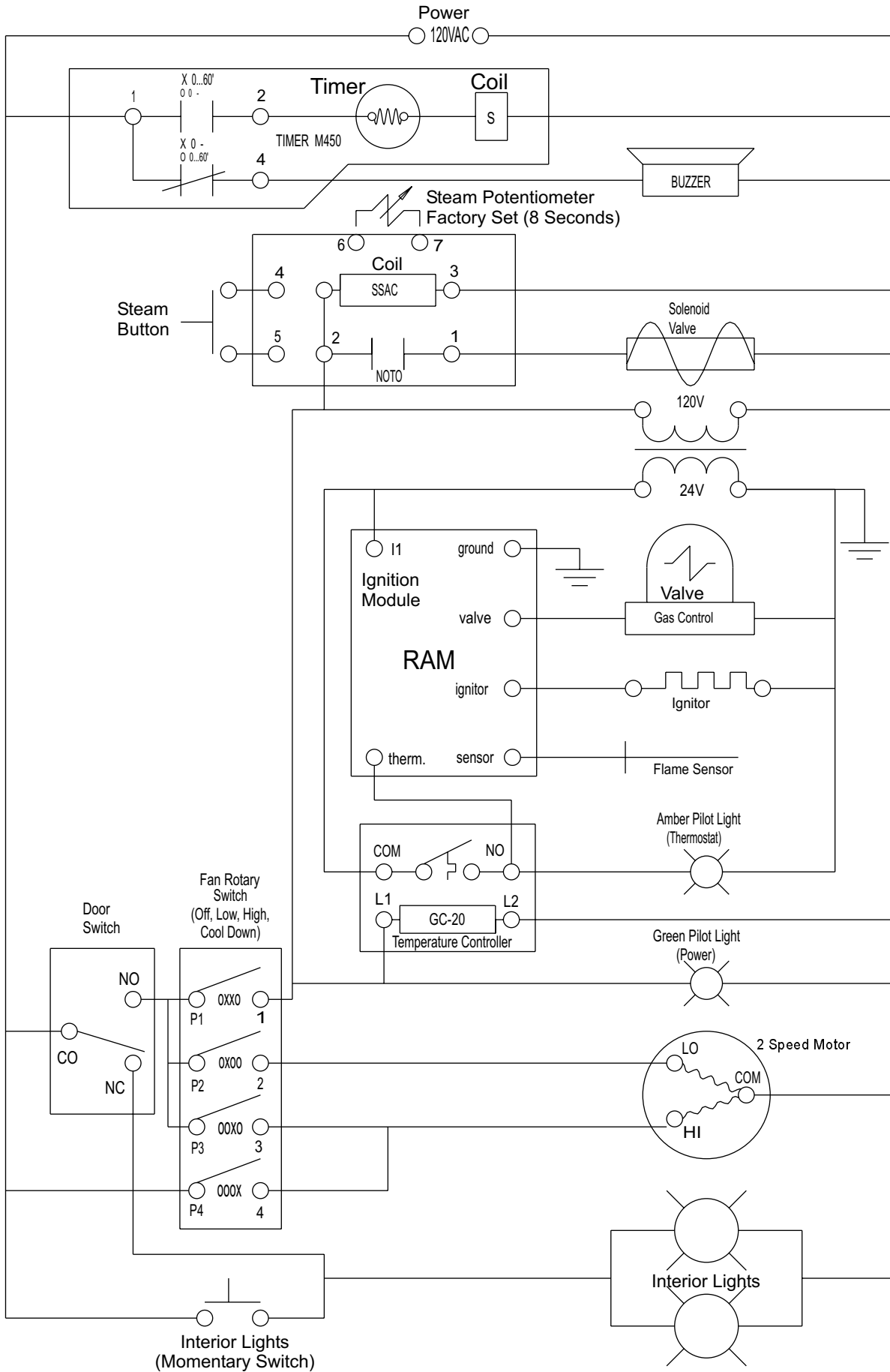

Fig. 5



6. CO11-G ELECTRICAL SCHEMATIC (ROTARY CONTROL)



7. CO11-G WIRING DIAGRAM (ROTARY CONTROL)

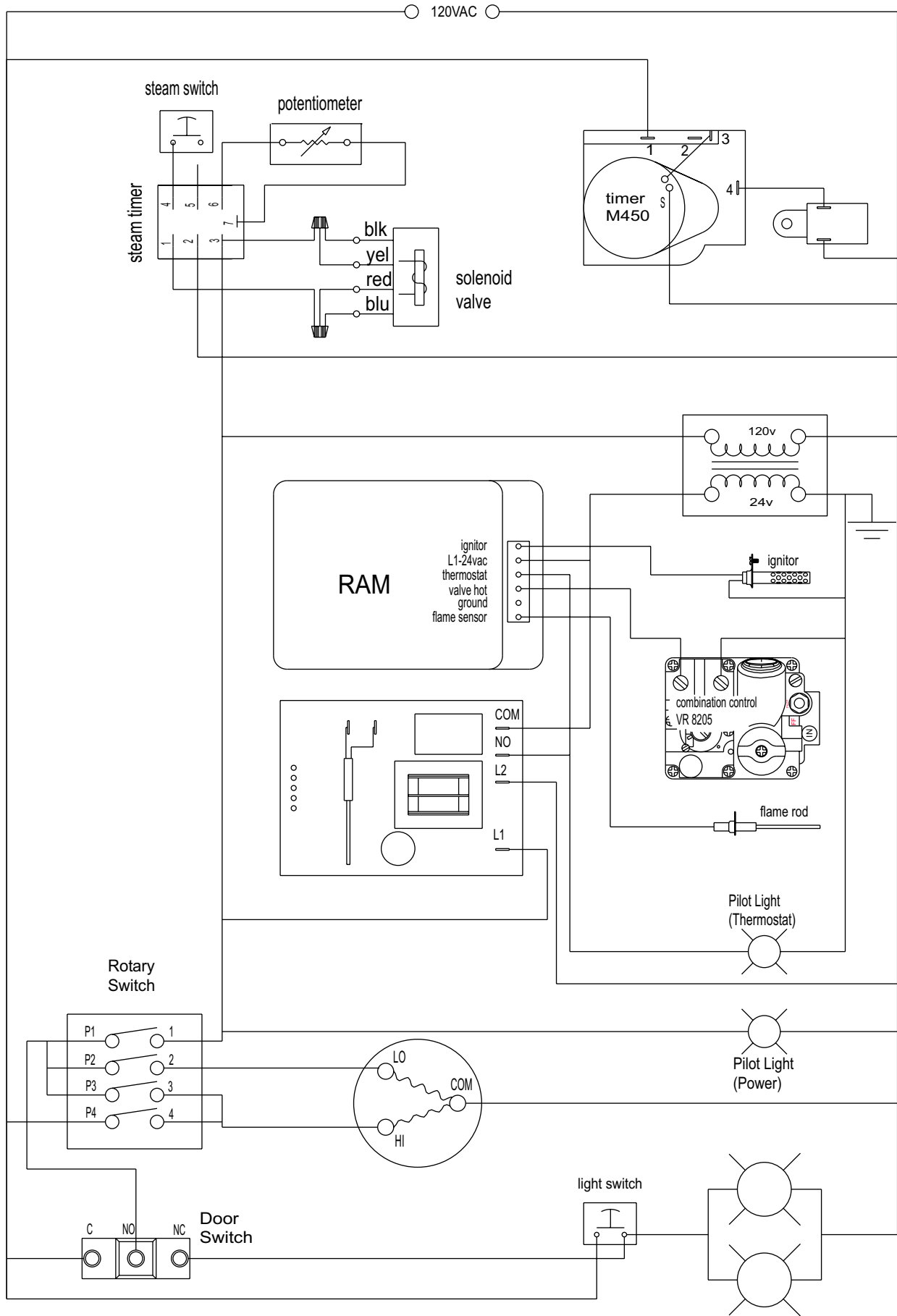

8. CO11-G WIRING DIAGRAM (w/PROGRAMMABLE CONTROLS) C&H-3

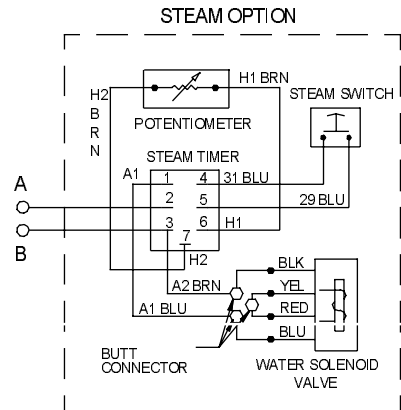
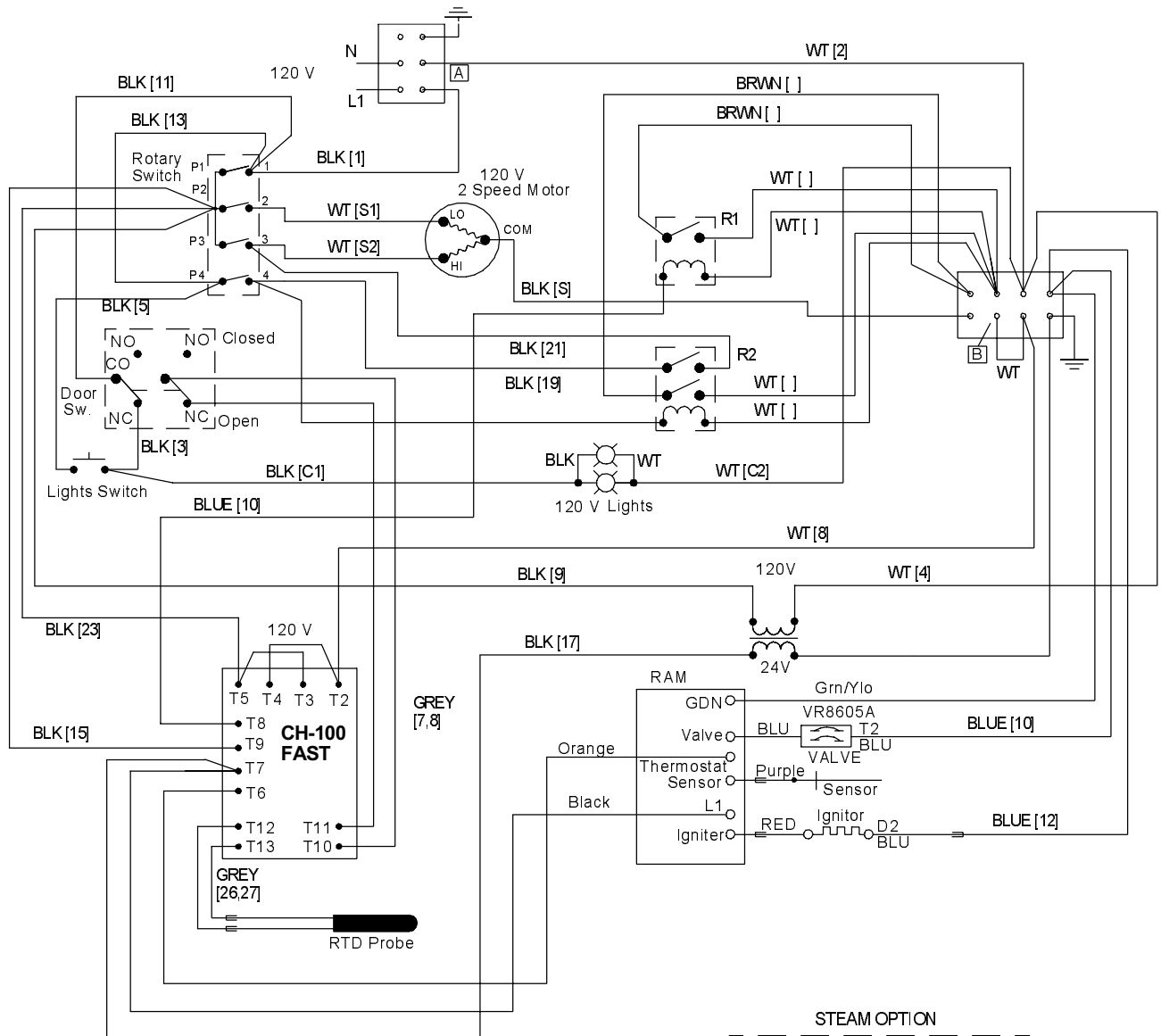

9. PARTS LISTS & EXPLODED VIEWS

C011-G

Full Size Gas Convection Oven

30 Pine Street • New Rochelle • New York • 10801

914 / 576 - 0200

914 / 576 - 0605 fax

1 - 800 - 431 - 2745 US & Canada

www.bakerspride.com web address



Figure B **Burners / Valve / Door Chain / Legs**

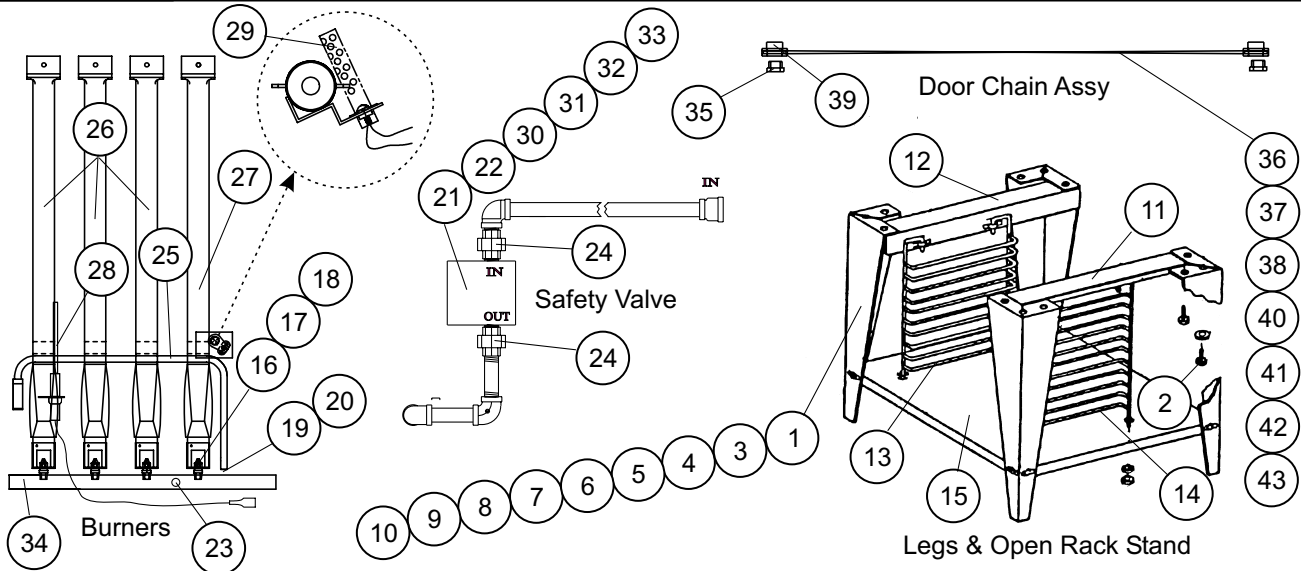

Item	Part #	Description	Item	Part #	Description
1	S1050Y	30" Leg (Set of 4)	23	N3068P	1/8" Pressure Tap Nozzle Assy
2	Q4017V	Leg Bolt, Set (For 4 Legs)	24	N3026A	1/2" Union
3	S1217Y	24 1/2" S/S Leg (Set/4) Used w/Casters	25	R3158A	Carry-Over
4	S1252T	24 1/2" S/S Leg (each) Used w/Casters	26	L5090A	Burner (3)
5	S1081X	Casters, 4" (Set of 4)	27	L5091X	Burner w/Ignitor Bracket (1)
6	S1022X	Caster, 4" (No Lock), each	28	M1323X	Flame Rod (Flame Sensor)
7	S1023X	Caster, 4" (w/Lock), each	29	M2140X	Igniter, 24V
8	K1357E	Mounting Plate (for Casters) each	30	R3164X	Combination Valve (Natural)
9	S1049Y	6" Bullet Legs (Set of 4)	31	R3165X	Combination Valve (LP)
10	S1049A	6" Bullet Legs (each)	32	R3178P	Combination Valve, CE (Natural)
11	E3148X	Top Right Angle, Open Rack Stand	33	R3179P	Combination Valve, CE (LP)
12	E3149X	Top Left Angle, Open Rack Stand	34	R1116A	Manifold
13	T3051X	Left Rack Support, Open Rack Stand	35	S3228A	Flange Bearing (4)
14	T3052X	Right Rack Support, Open Rack Stand	36	S3231X	Door Chain Assy (Complete)
15	T8075X	Bottom Shelf w/Hdwr, Open Rack Stand	37	S3226A	Door Chain Rod (Short)
16	R3180A	#48 Burner Orifice Spud (Nat)	38	S3227A	Door Chain Rod (Long)
17	R3175A	#57 Burner Orifice Spud (LP)	39	S3145X	Sprocket
18	R3176A	1.15mm Burner Orifice Spud CE (LP)	40	S3112X	Roller Chain #35
19	R3161X	#71 Carry-Over Orifice Hood (Nat)	41	S3224A	Chain Connection Link #41
20	R3160X	#78 Carry-Over Orifice Hood (LP)	42	S3223A	Turnbuckle 1/4-20x3"
21	M1233X	LP Kit (for Combination Valve)	43	Q2039A	1/4-20 Hex Nut, Left Hand Thread (2)
22	M1343A	Natural Kit (for Combination Valve)			

Steam Option (Not Shown)

N/S	M1114X	Solonoid Valve	N/S	N5815A	1/4 Tubing x 9"
N/S	M1115X	Coil (For Solonoid Valve)	N/S	N1019X	Steam Injection Nozzle
N/S	N3039A	1/8 Brass Coupling	N/S	M1175X	Steam Timer, 115V
N/S	N3040A	1/8 Brass Elbow	N/S	M1231A	Steam Timer, 208/240V (Export)
N/S	N5831A	1/8x4" Brass Nipple	N/S	M1176X	Steam Potentiometer
N/S	N3041A	1/8NPT-1/4 Compression Fitting	N/S	M1049X	Momentary Switch (Steam)
N/S	N5814A	1/8x2 3/8 Nipple			

Note: When ordering, ALWAYS specify Part #, Model #, Serial #, Voltage/Phase & type of Gas. 5/00

C011-G

Full Size Gas Convection Oven

30 Pine Street • New Rochelle • New York • 10801

914 / 576 - 0200

914 / 576 - 0605 fax

1 - 800 - 431 - 2745 US & Canada

www.bakerspride.com web address



Figure A

Exterior / Interior / Controls / Doors

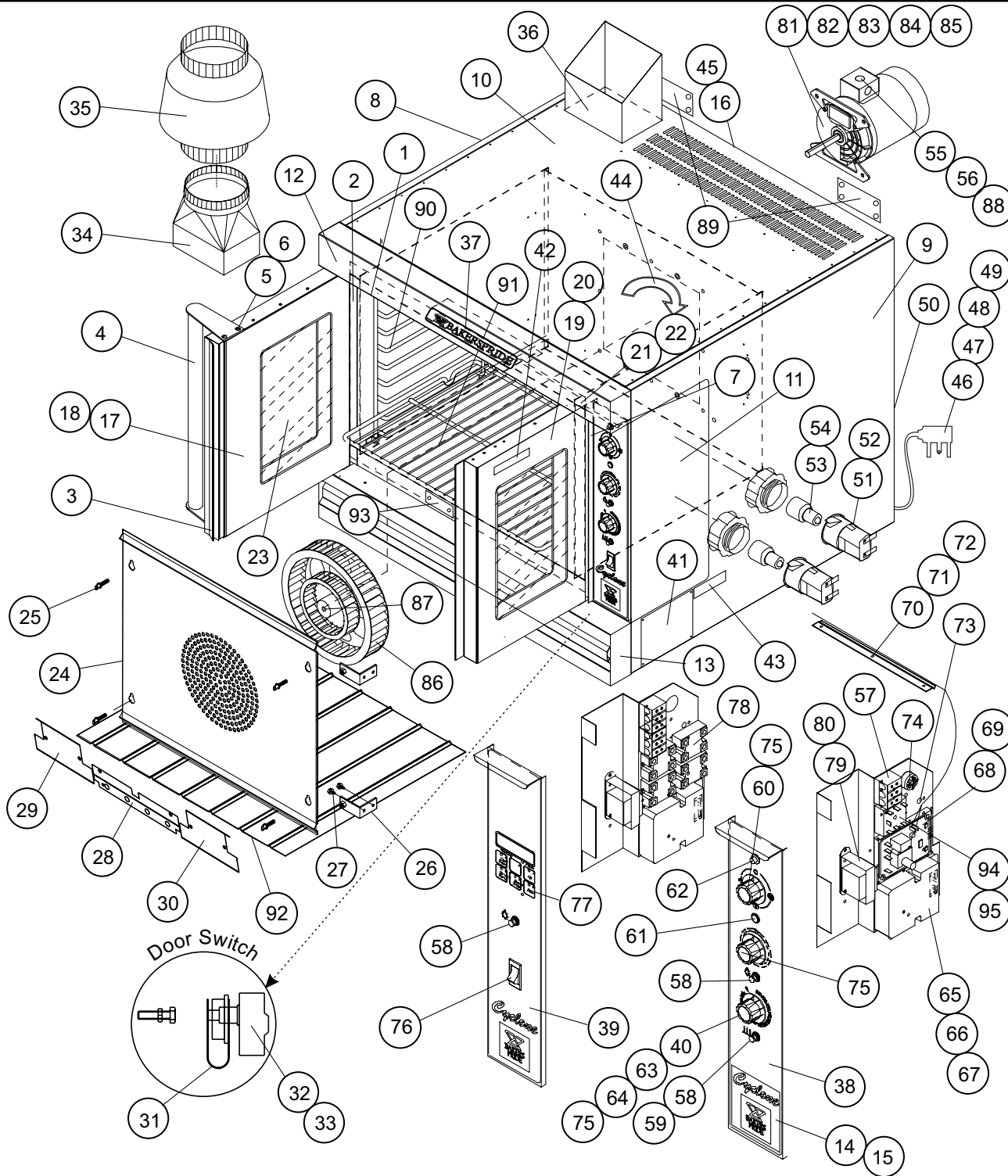

Note: When ordering, ALWAYS specify Part #, Model #, Serial #, Voltage/Phase & type of Gas.

5/00



30 Pine Street • New Rochelle • New York • 10801

914 / 576 - 0200

914 / 576 - 0605 fax

1 - 800 - 431 - 2745 US & Canada

www.bakerspride.com web address

CO11-G

Full Size Gas Convection Oven

Item	Part #	Description	Item	Part #	Description
Exterior / Interior / Controls / Doors					
1	E3450X	Door Seal, Top or Bottom, each (2)	49	P6007X	Elec Line Cord, 250V (UK)
2	E3451K	Door Seal, Sides, each (2)	50	N5048P	Rear Pipe Connection
3	E3466U	Door Closure Strip	51	P1144X	Snap-In Light Assy (w/130V Bulb)
4	S1317U	Door Handle	52	P1145X	Snap-In Light Assy (w/240V Bulb)
5	Q1477A	Screw, FH 10-32x1/2 (4)	53	P1146X	Light Bulb (15W, 130V)
6	Q3047A	#10 Lockwasher, Countersunk, Ext. (4)	54	P1147X	Light Bulb (15W,240V)
7	E3487X	Vertical Trim	55	P1082A	Conduit BX, 3/8"
8	E3485K	Outer Cover (Left)	56	P1084A	Bushing, Anti-Short, 3/8"
9	E3486K	Outer Cover (Right)	57	P1003X	Terminal Block (3 Pole)
10	E3501K	Outer Cover (Top)	58	M1049X	Switch, Momentary (Light &/or Steam)
11	E3499X	Access Cover (Side)	59	S1171A	Plug Button, 7/16"
12	E3488X	Top Trim	60	M1326X	Switch, Rotary (EGO)
13	E3490X	Bottom Apron	61	M1339A	Pilot Light Amber (Thermostat)
14	E3498X	Access Cover (Front)	62	M1340A	Pilot Light Green (Power)
15	S3203K	Latch Assy (Magnetic)	63	M1332X	Timer, 60 Minutes (120V)
16	E3514X	S/S Perforated Rear Panel	64	M1346X	Timer, 60 Minutes (208/240V)
17	E3454X	Door Assy Left (No Window)	65	M2138X	Ignition Control Module (24V)
18	E3458X	Door Assy Left (w/Window)	66	M1355A	Ignition Control Module, CE (24V)
19	E3456X	Door Assy Right (No Window)	67	M2139A	Harness w/Terminals
20	E3460X	Door Assy Right (w/Window)	68	M1203X	GC-20 T-stat w/Knob (120V)
21	S3229A	Door Rod	69	M1227X	GC-20 T-stat w/Knob (208/240V)
22	Q4033A	Roll Pin 1/4 x 1 1/4	70	M1204X	Temperature Sensor, 60"
23	S1048X	Window Assy	71	E3051K	Clamp, Temperature Sensor (1)
24	E3053K	Baffle Plate	72	P1042A	Victor Clip, Temp Sensor (3)
25	Q2009A	Thumb Screw, 1/4-20x1/2 (4)	73	M1176X	Potentiometer
26	E3095X	Baffle Plate Bracket Assy (4)	74	M1335X	Bell Audiolarm
27	Q1414A	Screw, Hex Hd, #10x3/4 (8)	75	S1311X	Knob (3)
28	E3481X	Combustion Chamber (Front Center)	76	M1352X	Ckt Breaker, 120-240V, 15A
29	E3482X	Combustion Chamber (Front Left)	77	M1306X	Minichief 2000 (Watlow)
30	E3511X	Combustion Chamber (Front Right)	78	M1356A	Solid State Relay, CE
31	E3471K	Door Switch Actuator	79	M1145X	Transformer (120V-24V)
32	M1102X	Microswitch (Rotary)	80	M1174X	Transformer (208/240V-24V)
33	M1172A	Microswitch (Minichief)	81	M1157X	Motor, 1/4HP, 2Spd, 115V, 60
34	R3166A	Flue Adapter 7" (For Direct Venting Only)	82	M1217X	Motor, 1/4HP, 2Spd, 200-230V,50-60
35	R3113A	Flue Diverter (For Direct Venting)	83	Q3008A	Flat Washer (4)
36	R3167A	Flue Diverter (For Collection Hood)	84	Q3014A	Lock Washer, Split (4)
37	U1043X	Bakers Pride Name Plate (13 3/4")	85	Q2204A	Nut, 5/16 HX, 5/16-18 (4)
38	U1290A	Control Panel Overlay (Rotary)	86	S1195X	Blower Wheel
39	U1291A	Control Panel Overlay (Minichief)	87	Q2302A	Bolt, Wheel Puller 3/8-16x2 Hx (2)
40	U1296A	Timer Overlay (50 cycle only)	88	P1108A	Conduit Connector, 3/8"x1/2", 90 deg.
41	U1216A	Rating Plate	89	E3225X	Stacking Bracket, CO11-G2 Only (each)
42	U1055A	Caution Hot Label	90	T3044A	Rack Support
43	U1128A	Supply Connection	91	T3043A	Wire Rack
44	U1169A	Motor Rotation Arrow	92	E3483K	Flame Guard
45	U1210A	Installation Warning	93	E3531K	Door Limit Block
46	P6004X	Elec Line Cord, 115V (US & Can)	94	M1175X	Steam Timer, 115V
47	P6005X	Elec Line Cord, 250V (US & Can)	95	M1231A	Steam Timer, 208/240V (Export)
48	P6006X	Elec Line Cord, 250V (Europe)			
Conversion Kit (Natural to LP)			Conversion Kit (LP to Natural)		
4	R3175A	#57 Burner Orifice Spud, LP	4	R3180A	#48 Burner Orifice Spud, Nat
1	M1233X	LP Kit for Combination Valve	1	M1343X	Natural Kit for Combination Valve
1	R3160X	#78 Carry-over Orifice Hood, LP	1	R3161X	#71 Carry-over Orifice Hood, Nat

5/00

Note: When ordering, ALWAYS specify Part #, Model #, Serial #, Voltage/Phase & type of Gas.



10. BAKERS PRIDE LIMITED WARRANTY

30 Pine Street New Rochelle, New York 10801
914 / 576 - 0200 • US & Canada: 1 - 800 - 431 - 2745 • fax 914 / 576 - 0605

- WHAT IS COVERED** This warranty covers defects in material and workmanship under normal use, and applies only to the original purchaser providing that:
- ◆ The equipment has not been accidentally or intentionally damaged, altered or misused;
 - ◆ The equipment is properly installed, adjusted, operated and maintained in accordance with National and local codes, and in accordance with the installation instruction provided with the product;
 - ◆ The serial number rating plate affixed to the equipment has not been defaced or removed.
- WHO IS COVERED** This warranty is extended to the original purchaser and applies only to equipment purchased for use in the U.S.A.
- COVERAGE PERIOD** Cyclone Convection Ovens: BCO Models: One (1) Year limited parts and labor; (1) Year limited door warranty.
GDCCO Models: Two (2) Year limited parts and labor; (2) Year limited door warranty.
CO11 Models: Two (2) Year limited parts and labor; (5) Year limited door warranty.
All Other Products: One (1) Year limited parts and labor. Warranty period begins the date of dealer invoice to customer or ninety (90) days after shipment date from BAKERS PRIDE - whichever comes first.
- WARRANTY COVERAGE** This warranty covers on-site labor, parts and reasonable travel time and travel expenses of the authorized service representative up to (100) miles, round trip, and (2) hours travel time. The purchaser, however, shall be responsible for all expenses related to travel, including time, mileage and shipping expenses on smaller counter models that may be carried into a Factory Authorized Service Center, including the following models: PX-14, PX-16, P18, P22S, P24S, PD-4, PDC, WS Series and BK-18.
- EXCEPTIONS** All removable parts in BAKERS PRIDE Char-broilers, including but not limited to: Burners, Grates, Radiants, Stones and Valves, are covered for a period of SIX MONTHS.
All Ceramic Baking Decks are covered for a period of THREE MONTHS. The installation of these replacement decks is the responsibility of the purchaser.
The extended Cyclone door warranty years 3 through 5 is a parts only warranty and does not include labor, travel, mileage or any other charges.
- EXCLUSIONS**
- ◆ Negligence or acts of God,
 - ◆ Thermostat calibrations after (30) days from equipment installation date,
 - ◆ Air and Gas adjustments,
 - ◆ Light bulbs,
 - ◆ Glass doors and door adjustments,
 - ◆ Fuses,
 - ◆ Char-broiler work decks and cutting boards,
 - ◆ Tightening of conveyor chains,
 - ◆ Adjustments to burner flames and cleaning of pilot burners,
 - ◆ Tightening of screws or fasteners,
 - ◆ Failures caused by erratic voltages or gas supplies,
 - ◆ Unauthorized repair by anyone other than a BAKERS PRIDE Factory Authorized Service Center,
 - ◆ Damage in shipment,
 - ◆ Alteration, misuse or improper installation,
 - ◆ Thermostats and safety valves with broken capillary tubes,
 - ◆ Accessories — spatulas, forks, steak turners, grate lifters, oven brushes, scrapers, peels, etc.,
 - ◆ Freight — other than normal UPS charges,
 - ◆ Ordinary wear and tear.
- INSTALLATION** Leveling and installation of decks, as well as proper installation and check out of all new equipment — per appropriate installation and use materials — is the responsibility of the dealer or installer, not the manufacturer.
- REPLACEMENT PARTS** BAKERS PRIDE genuine Factory OEM parts receive a (90) day materials warranty effective from the date of installation by a BAKERS PRIDE Factory Authorized Service Center.

This Warranty is in lieu of all other warranties, expressed or implied, and all other obligations or liabilities on the manufacturers part. BAKERS PRIDE shall in no event be liable for any special, indirect or consequential damages, or in any event for damages in excess of the purchase price of the unit. The repair or replacement of proven defective parts shall constitute a fulfillment of all obligations under the terms of this warranty.

Form #U4177A 3/04