

Atlas Metal INDUSTRIES, INC.

Subsidiary of Mercury Aircraft, Inc.

1135 N.W. 159th DR., MIAMI, FL 33169

PHONE (305) 625-2451, (800) 762-7565, FAX (305) 623-0475, E-mail: sales@atlasfoodserv.com

PARTS LIST BUILT-IN/SLIDE-IN REFRIGERATED BASE- OPEN TOP SANDWICH UNIT SU SERIES

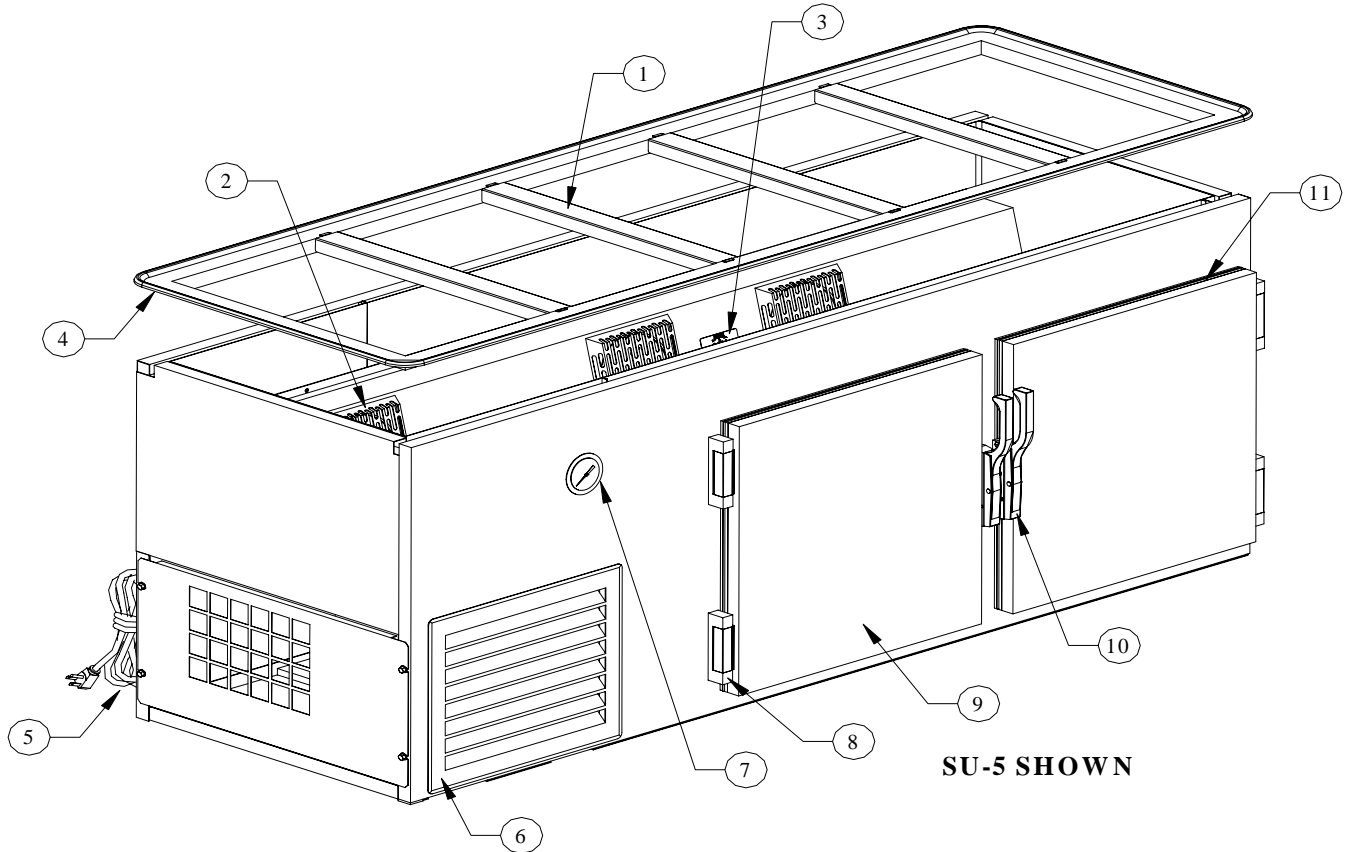

ITEM NUMBER	PART NUMBER	DESCRIPTION	ITEM NUMBER	PART NUMBER	DESCRIPTION
1	S80103-0	Separator Channel	13	2002-2	1/3 H.P. Compressor (Not Shown)
2	S81441-0	Fan Guard	14	S81419-0	Fan Bracket (Not Shown)
3	22-1406	Thermostat	15	S90410-4	Drain Pan SU-4 (Not Shown)
4	7002-0+Model #	Vinyl Bead Gasket	16	S90410-5	Drain Pan SU-5 (Not Shown)
5	1004-0	Power Cord	17	2013-0	Fan Motor (Not Shown)
6	S84054-0	Grill Front	18	2026-0	0.042 Cap Tube (Not Shown)
7	113-5	Thermometer	19	2014-8	Fan Blade (Left) (Not Shown)
8	6053-8	Hinge & Cover	20	2014-5	Fan Blade (Right) (Not Shown)
9	S90253-4	Door Assembly SU-4, SU-6	21	20-3010	Timer (Not Shown)
	S90454-5	Door Assembly SU-5, SU-6		22	2060-1
10	6055-1	Slam Action Latch	23		S90430-0
	97-105	Door Gasket SU-4, SU-6		24	S90429-0
11	97-106	Door Gasket SU-5, SU-6			2023-0
	12	2020-1	Evap. Coil, SU-4, 5 (Not Shown)		

BUILT-IN/SLIDE-IN REFRIGERATED BASE-OPEN TOP SANDWICH UNIT

SU SERIES

INSTALLATION

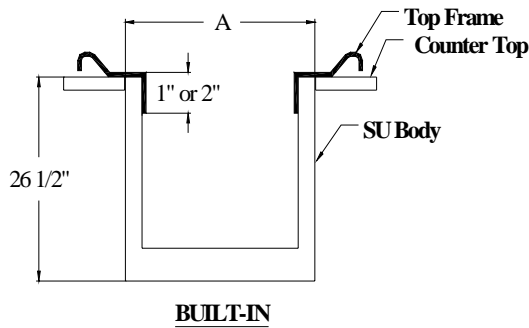

Counter Cut-Out	
Model	A
SU-4	23 1/2" X 55 1/2"
SU-5	23 1/2" X 69 1/4"
SU-6	23 1/2" X 83"

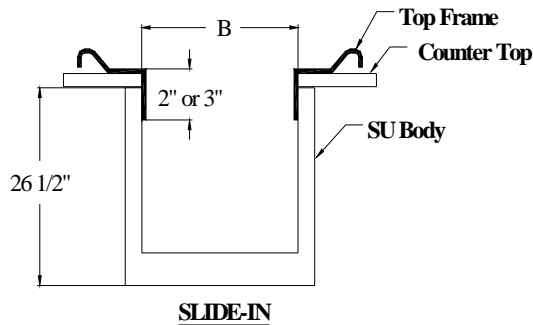

Model	B
SU-4	20" X 53 1/2"
SU-5	20" X 67"
SU-6	20" X 80 3/4"

OPERATION

The unit is ready to operate as soon as it is plugged in and turned on. The thermostat has an off position and numbers from #1 through #7 (number 7 is the coldest). The unit has been pre-tested and set for proper operation with the thermostat set for 35° to 40°. For maximum efficiency, food pans or covers must be placed in all pan openings. Do not block air discharge openings inside the base of the unit. The timer is installed in the system to shut the compressor off every 4 hours (approximately 15 minutes) to eliminate ice build up on the evaporator coil. The unit is supplied with a power cord and NEMA plug. Refer to the data plate located in the compressor compartment for the amperage and voltage information. Use a licensed electrician when installing power source. **Note:** Proper ventilation must be provided in counter.

MAINTENANCE

NEVER CLEAN THE UNIT WITH A CHLORIDE BASED PRODUCT. CHLORIDES OR IMPROPER CLEANING COULD SCAR, MARK AND/OR CORRODE METAL. **DO NOT** USE STEEL WOOL OR ABRASIVE PRODUCTS. TO CLEAN USE SOAPY WARM WATER, RINSE THOROUGHLY TO REMOVE ALL RESIDUES. CLEAN CONDENSER COIL REGULARLY. **FAILURE TO MEET THESE CONDITIONS WILL VOID WARRANTY.**