

Atlas Metal INDUSTRIES, INC.

Subsidiary of Mercury Aircraft, Inc.

1135 N.W. 159th DR., MIAMI, FL 33169

PHONE (305) 625-2451, (800) 762-7565, FAX (305) 623-0475, E-mail: sales@atlasfoodserv.com

WIH-REMOTE INSTALLATION

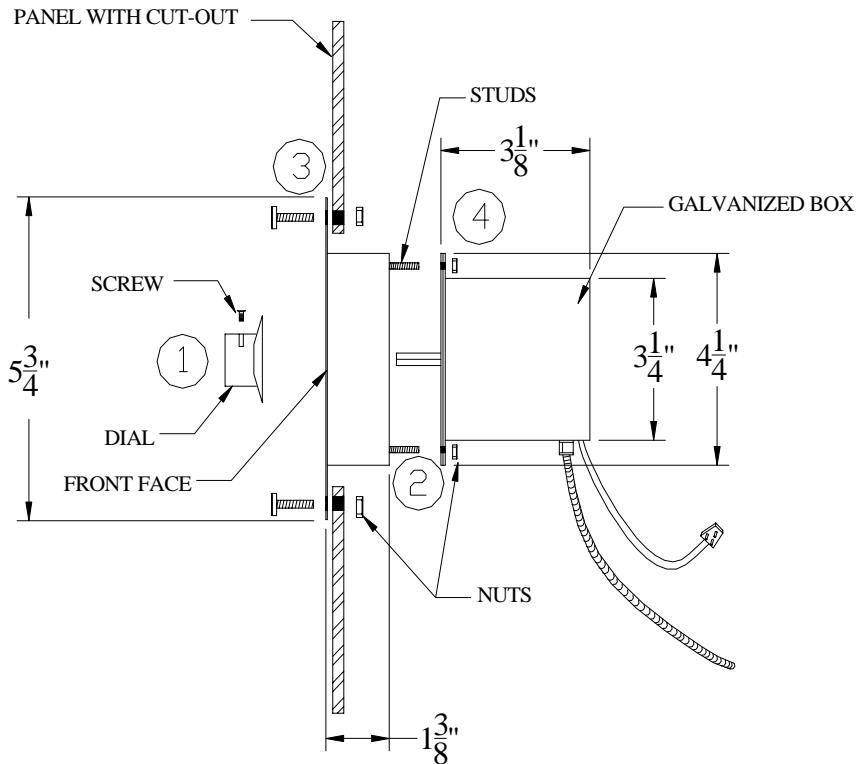

INSTALLATION OF THE REMOTE CONTROL HOT UNITS.

Provide the correct Cut-Out opening for the remote control panel (see chart below).

Remove control box from the bottom of the unit.

- 1) Remove black control dial from front of control panel by loosening screws.
- 2) Remove 6/32 fiber nuts from the back of the control box.
- 3) Mount the S/S front plate to the Cut-Out in apron.
- 4) Attach the galvanized box to the S/S front plate.

The unit is ready to be connected to the electrical receptacle. Refer to the data plate on the control panel for the amperage and voltage information. Use a licensed electrician when installing power source.

| MODEL | CUT-OUT SIZE |
|-------|----------------|
| 1 | 4 1/2 x 6 1/4 |
| 2 | 4 1/2 x 12 1/4 |
| 3 | 4 1/2 x 26 |
| 4 | 4 1/2 x 39 3/4 |
| 5 | 4 1/2 x 53 1/2 |
| 6 | 4 1/2 x 67 1/4 |

CAUTION: HANDLE CONTROL PANEL & CONDUIT CAREFULLY, THERMOSTAT CAPILLARY TUBE IS VERY FRAGILE, IF BROKEN, HEATING SYSTEM WILL NOT OPERATE.

FAILURE TO MEET THESE CONDITIONS WILL VOID WARRANTY.