

**Atlas Metal**  
INDUSTRIES, INC.

*Subsidiary of Mercury Aircraft, Inc.*

1135 N.W. 159th DR., MIAMI, FL 33169

PHONE (305) 625-2451, (800) 762-7565, FAX (305) 623-0475, E-mail: [sales@atlasfoodserv.com](mailto:sales@atlasfoodserv.com)

## PARTS LIST FOR CONDIMENT RAIL WCRM

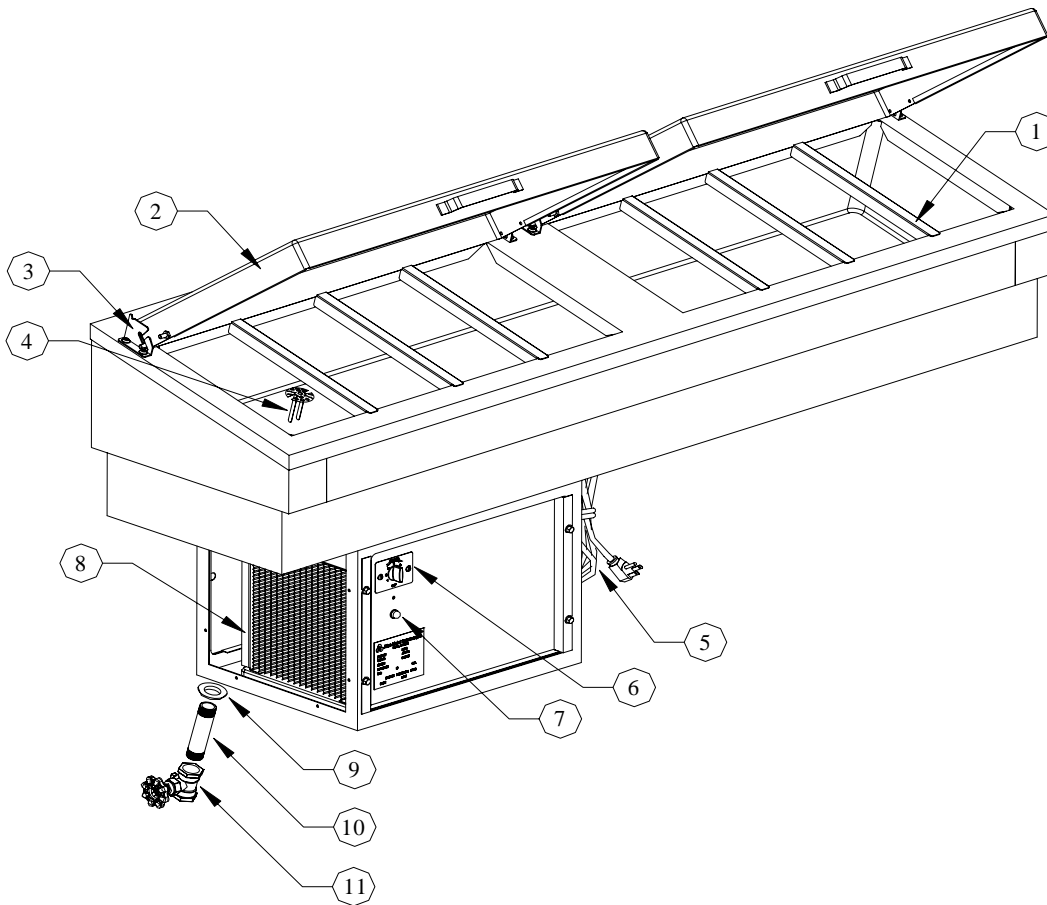

ITEM NUMBER	PART NUMBER	DESCRIPTION
1	S80109-0	1/6 Pan Divider
2	S81453-0	Cover with Handle
3	90-9900	Hinge Bracket
4	86-3202	Perforated Snap-In Drain
5	1003-0	Power Cord
6	2044-0	Thermostat
7	1099-0	Pilot Light
8	2029-0	1/5 H.P. Compressor
9	49-1028	Grommet
10	30-3130	3/4" P.V.C Nipple
11	3016-1	3/4" Gate Valve
12	2027-0	0.031 Cap Tube (Not Shown)
13	2025-0	Drier (Not Shown)
16	600008	Thermostat Knob

# REFRIGERATED CONDIMENT RAIL

## WCRM

---

### INSTALLATION

Provide a 15" x 62" cut-out in the counter top and drop the unit in.

A non-toxic silicone sealer may be used between the flange and counter top.

The unit should be level for draining purposes. When installing unit in a counter, it is recommended that the operator side be completely open for air circulation. When this is not possible, such as an island counter, it is recommended that two grill openings are provided approximately 18" x 18" of free air for intake and exhaust at the opposite ends of the counter.

The unit is supplied with a power cord and a NEMA plug. Refer to the data plate on the compressor housing for the amperage and voltage information. Use a licensed electrician when installing power source.

---

### OPERATION

The unit is ready to operate as soon as it is plugged in. The thermostat has an off position and numbers from 1 through 7 (number 7 is the coldest). The unit should be turned off every day after use and turned on one hour before use.

---

### MAINTENANCE

**NEVER** CLEAN PANS WITH A CHLORIDE BASED PRODUCT. CHLORIDES OR IMPROPER CLEANING COULD SCAR, MARK AND/OR CORRODE PANS. **DO NOT** USE STEEL WOOL OR ABRASIVE PRODUCTS. TO CLEAN USE SOAPY WARM WATER, RINSE THOROUGHLY TO REMOVE ALL RESIDUES. CLEAN CONDENSER COIL REGULARLY. **FAILURE TO MEET THESE CONDITIONS WILL VOID WARRANTY.**