

INSTALLATION  
AND  
OPERATING  
INSTRUCTIONS

# TORTILLA GRILL

**MODELS: TBTGIL & TBTGDL**



**NOTICE:** This product is intended for commercial use only. Not for household use.



**WARNING:** Improper installation, operation, service or maintenance can cause property damage, injury or death. Read and understand these instructions thoroughly before positioning, installing, maintaining or servicing this equipment.



### IMPORTANT FOR FUTURE REFERENCE

Please complete this information and retain this manual for the life of the equipment. For Warranty Service and/or Parts, this information is required.

\_\_\_\_\_ Model Number

\_\_\_\_\_ Serial Number

\_\_\_\_\_ Date Purchased

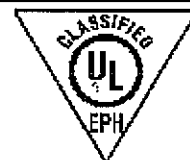

ANSI/NSF4

APW WYOTT Foodservice Equipment Company  
P.O. Box 1829  
Cheyenne, WY 82003

P/N 4881565 Rev. A 10-06

+1 (307) 634-5801 Phone  
+1 (307) 637-8071 FAX

+1 (800) 752-0863 Toll Free  
[www.apwwyott.com](http://www.apwwyott.com)

## TABLE OF CONTENTS:

ITEM	PAGE	ITEM	PAGE
Safety Precautions	2	Cleaning	5
Owners Information	3	Troubleshooting	5
Warranty Information	3	Preventative Maintenance Schedule	6
Specifications	3	Wiring Diagram Parts	6
Installation Instructions	4	List w/Exploded View	6
Operation	4	Warranty	8

Congratulations on your purchase of APW Wyott commercial cooking or refrigeration equipment. APW Wyott takes pride in the design and quality of its products. When used as intended and with proper care and maintenance, you will experience years of reliable operation from this equipment. To ensure best results, it is important that you read and follow the instructions in this manual carefully.

**IMMEDIATELY INSPECT FOR SHIPPING DAMAGE** All containers should be examined for damage before and during unloading. The freight carrier has assumed responsibility for its safe transit and delivery. If equipment is received damaged, either apparent or concealed, a claim must be made with the delivering carrier.



A) Apparent damage or loss must be noted on the freight bill at the time of delivery. It must then be signed by the carrier representative (Driver). If this is not done, the carrier may refuse the claim. The carrier can supply the necessary forms.



B) For concealed damage or loss, if not apparent until after equipment is uncrated, a request for inspection must be made to the carrier within 15 days. The carrier should arrange an inspection. Be certain to hold all contents and packaging material.



Installation and start-up should be performed by a qualified installer who thoroughly read, understands and follows these instructions.



If you have questions concerning the installation, operation, maintenance or service of this product, write Technical Service Department APW Wyott Foodservice Equipment Company, P.O. Box 1829, Cheyenne, WY 82003. \

## SAFETY PRECAUTIONS

 **DANGER:** This symbol warns of imminent hazard which will result in serious injury or death. 

 **WARNING:** This symbol refers to a potential hazard or unsafe practice, which could result in serious injury or death. 

 **CAUTION:** This symbol refers to a potential hazard or unsafe practice, which may result in minor or moderate injury or product or property damage. 

 **NOTICE:** This symbol refers to information that needs special attention or must be fully understood even though not dangerous. 



**CAUTION:** APW Wyott equipment is designed, built, and sold for commercial use and should be operated by trained personnel only. Clearly post all CAUTIONS, WARNINGS and OPERATING INSTRUCTIONS near each unit to insure proper operation and to reduce the chance of personal injury and/or equipment damage. This product is used for the hot holding of food products only.



**WARNING:** Always disconnect power before servicing the unit. Surfaces will remain hot after power has been turned off. Allow unit to cool before cleaning or servicing. Never clean the unit by immersing it in water. The unit is not protected against water jets: DO NOT CLEAN DRY-WELL WITH A WATER JET. Always clean equipment properly before first use.



## OWNER'S INFORMATION

### General Information:

1. Always clean equipment thoroughly before first use. (See general cleaning instructions.)
2. Check rating label for your model designation and electrical rating.

### General Operation Instructions:

1. All foodservice equipment should be operated by trained personnel.
2. Do not allow your customers to come in contact with any surface labeled "CAUTION HOT".
3. Never touch Grill platen or body while operating.

## WARRANTY INFORMATION

### Reliability Backed By APW Wyott's Warranty:

All APW Wyott Drywells are backed by a one year parts and labor warranty, including On-Site Service calls within 50 miles of authorized service technicians.

### Service Information:

Service Hotline (800) 733-2203

## SPECIFICATIONS

### Dimensions:

Dual Line Grill:	40.00" W x 26.25" D x 3.61" H
I-Line Grill:	24.60" W x 20.80" D x 3.61" H

### Electrical Ratings for Grills:

Dual Line Grill:	3200/3563W, 208/240V, 12.5/14.9A (Single Phase)
I-Line:	1200/1600W, 208/240V, 5.7/6.7A (Single Phase)

Note: these units are to be wired to the switch and then to the breaker.

### Power Cord:

The Grill is designed to be hard wired to respective breaker.

### Shipping Weight:

Dual Line Grill:	92 lbs. (42kg)
I-Line Grill:	45 lbs. (21kg)

## INSTALLATION INSTRUCTIONS

If the carton appears damaged, or damage is discovered once the carton is opened, stop immediately and contact the freight company to file a damage claim.

1. Remove all external packaging that is protecting unit.
2. Remove unit from shipping container while in packaged position. The unit can be lifted and oriented to where the grill surface is facing up.
3. Remove all packaging from the unit.
4. Visually inspect all external and internal portions of unit for damage.
5. Wipe down the exterior of the unit using a cloth with warm water. NOTE: ONLY USE APPROVED CLEANING SOLUTIONS; i.e., SIZZLE.
6. Place unit in operating location. Make sure that the operating location is in an area where the ambient temperature is held constant (minimum 70°F). Please avoid areas such as near exhaust fans and air conditioning ducts. Support arms are used to weld to existing structure. Ensure that Grill is level, left to right & front to back.

## OPERATION

1. The switch that operates the grill is located on the Drive Through side of the assembly line.
2. The On/Off switch is used to turn the unit on or off. Once the unit is turned on the platen and frame surfaces will reach 425°F.
3. **Note:** Before touching the On/Off switch, please read the following statements: The unit's external surface temperatures will be hot. Use caution when touching these areas to avoid injury.
4. The Grill has thermostat(s) located in the center of the platen.

### Caution

### Warning

*External Surface Temperatures could cause Severe Burns*

**Do not touch platens, wells or fins once power is applied**

### Control Operation

This Grill has one heated zone and is operated by a toggle switch. The switch is labeled Tortilla Grill. It also has ON/OFF on the label.

# CLEANING

## Procedure Frequency:

Daily at Closing

## Supplies:

Soap and Warm Water  
Angled Grill Tool  
Grill Pad

Protective Fry Gloves  
Food Service Towels



**WARNING:** DO NOT immerse GRILL assembly or platen in water.



**WARNING:** DO NOT move GRILL from production line.



**WARNING:** DO NOT touch Grill surfaces without wearing a protective fry glove.



**WARNING:** DO NOT use unapproved abrasive pads or cleaning solutions.



## Procedure (Daily):

1. Turn off Grill and allow time for cooling.

**NOTE: DO NOT add ice or water to the Grill surface to accelerate cooling, this can damage the platen. Allow time for platen to cool.**

2. Dampen a cloth with soapy water and or Sizzle.
3. Apply the damp cloth to the platen and stainless steel trim, but do not pour soapy water onto platen surface.

**NOTE: Typical cleaning should require small amount of nonabrasive cleaner.**

4. Apply adequate pressure to the damp cloth to remove soil; hard scrubbing is not necessary.
5. Wet a clean towel and ring out the excess water in sink or bucket.
6. Wipe platen surface with damp towel to remove left over soap, Sizzle and soil from platen surface and stainless steel trim.
7. Rinse the towel and wipe the platen surface again until platen is absolutely clean.

# TROUBLESHOOTING

Always ask and check the following:

## Not getting power:

1. Is the unit connected to a live power source of the proper voltage?
2. Check the rating label. Is the unit connected to the correct power source?
3. Check the circuit breaker.
4. Is power switch "ON"?
5. If the above checks out, and you still have problems, call your local service agent.

# PREVENTATIVE MAINTENANCE SCHEDULE

Please follow the cleaning section for the daily preventative maintenance schedule.

- ➔ DO NOT USE ABRASIVES OR CLEANING SOLUTIONS ON THIS APPLIANCE.
- ➔ DO NOT IMMERSE THE GRILL IN WATER.
- ➔ DO NOT ATTEMPT TO MAINTENANCE, OR SERVICE THE UNDERSIDE OF THE GRILL.

## WIRING DIAGRAM

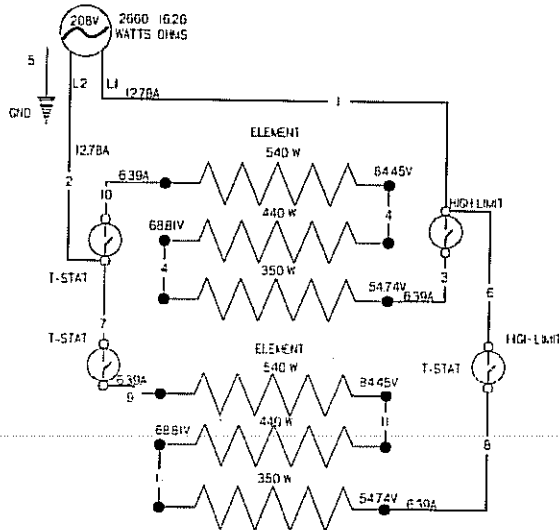

## PARTS LIST w/EXPLODED VIEW

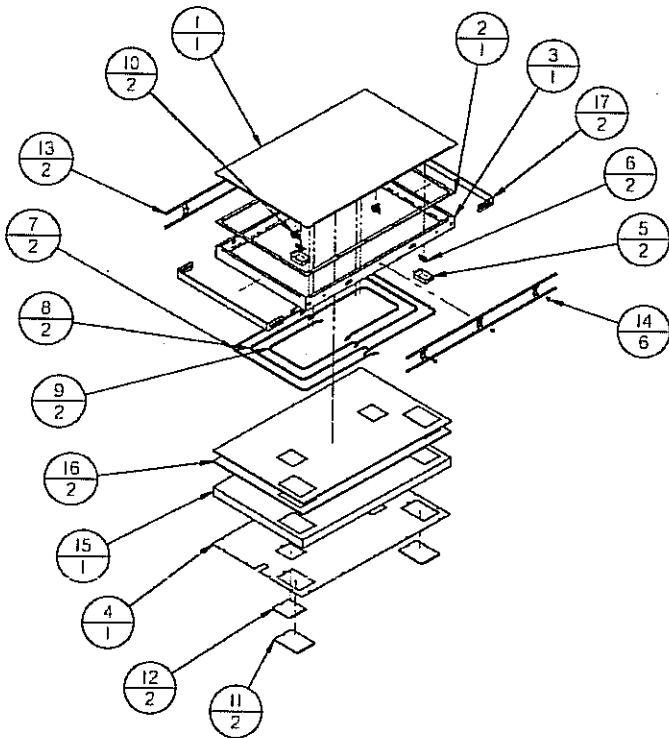

Item Number	Document Number	Quantity	Title
1	4881520	1	PLATE, 40 X 25 DUAL LINE GRILL
2	4881534	1	GASKET
3	4881521	1	WASSY, MAIN FRAME
4	4881529	1	BOTTOM PANEL
5	4881519	2	COVER, THERMOSTAT
6	1488100	2	THERMOSTAT, SNAP ACTION OPEN 450°F
7	4881592	2	ELEMENT, OUTER 84V 543W
8	4881593	2	ELEMENT, MID 69V 442W
9	4881594	2	ELEMENT, INNER 55V 353W
10	4881541	2	SWITCH, HIGH LIMIT
11	4881517	2	COVER, PLATE
12	4881530	2	COVER, ACCESS
13	4881531	2	WASSY, BURN GUARD
14	8205500	6	SCREW, 1/4-20 X 1/2 TR HD
15	4881514	1	INSULATION, 2" SUPER WOOL
16	4881518	2	INSULATION, .250 PYROGEL
17	4881539	2	BRACKET, MOUNT

## WIRING DIAGRAM

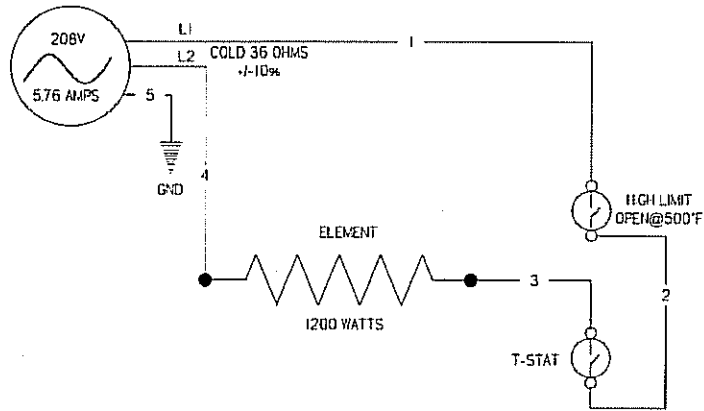

## PARTS LIST w/EXPLODED VIEW

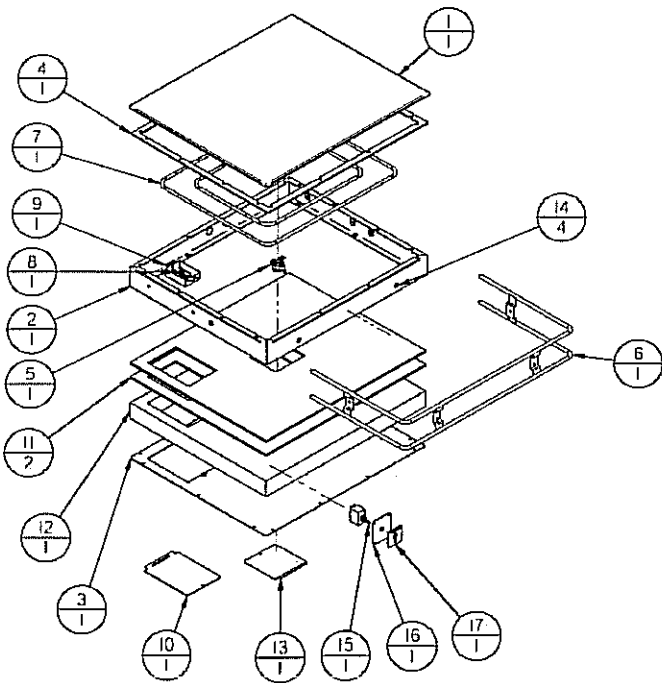

Item Number	Document Number	Quantity	Title
1	4881507	1	PLATE, 1-LINE, GRILL, FINISHED
2	4881546	1	WASSY, MAIN FRAME
3		1	
4	4881557	1	GASKET
5	4881541	1	SWITCH, HIGH LIMIT
6	4881562	1	WELDMENT, BURN GUARD
7	4881598	1	ELEMENT, 1 LINE GRILL 208V
8	1489100	1	THERMOSTAT, SNAP ACTION OPEN 450°F
9	4881519	1	COVER, THERMOSTAT
10	4881517	1	COVER, PLATE
11	4881513	2	INSULATION, 250° PYROGEL
12	4881512	1	INSULATION, SUPER WOOL 2"
13	4881530	1	COVER, ACCESS
14	8205500	4	SCREW, 1/4-20 X 1/2 TR HD
15	1302900	1	SWITCH, ON-OFF 30 AMP DPST
16	4881537	1	PLATE, SWITCH
17	4881536	1	LABEL, ON/OFF

## APW WYOTT EQUIPMENT LIMITED WARRANTY

APW Wyott Foodservice Equipment Company warrants its equipment against defects in materials and workmanship, subject to the following conditions:

This warranty applies to the original owner only and is not assignable.

Should any product fail to function in its intended manner under normal use within the limits defined in this warranty, at the option of APW Wyott such product will be repaired or replaced by APW Wyott or its Authorized Service Agency. APW Wyott will only be responsible for charges incurred or service performed by its Authorized Service Agencies. The use of other than APW Wyott Authorized Service Agencies will void this warranty and APW Wyott will not be responsible for such work or any charges associated with same. The closest APW Wyott Authorized Service Agent must be used.

This warranty covers products shipped into the 48 contiguous United States, Hawaii, metropolitan areas of Alaska and Canada. There will be no labor coverage for equipment located on any island not connected by roadway to the mainland.

Warranty coverage on products used outside the 48 contiguous United States, Hawaii, and metropolitan areas of Alaska and Canada may vary. Contact the international APW Wyott distributor, dealer, or service agency for details.

### Time Period

One year for parts and one year for labor, effective from the date of purchase by the original owner. The Authorized Service Agency may, at their option, require proof of purchase. Parts replaced under this warranty are warranted for the un-expired portion of the original product warranty only.

### Exceptions

- \*Gas/Electric Cookline: Models GCB, GCRB, GF, GGM, GGT, CHP-H, EF, EG, EHP. Three (3) Year Warranty on all component parts, except switches and thermostats. (2 additional years on parts only. No labor on second or third year.)
- \*Broiler Briquettes, Rock Grates, Cooking Grates, Burner Shields, Fireboxes: 90 Day Material Only. No Labor.
- \*Heat Strips: Models FD, FDL, FDD, FDDL. Two (2) Year Warranty on element only. No labor second year.
- \*Glass Windows, Doors, Seals, Rubber Seals, Light Bulbs: 90 Day Material Only. No Labor.

In all cases, parts covered by extended warranty will be shipped FOB the factory after the first year.

### Portable Carry In Products

Equipment weighing over 70 pounds or permanently installed will be serviced on-site as per the terms of this warranty. Equipment weighing 70 pounds or under, and which is not permanently installed, i.e. with cord and plug, is considered portable and is subject to the following warranty handling limitations. If portable equipment fails to operate in its intended manner on the first day of connection, or use, at APW Wyott's option or its Authorized Service Agency, it will be serviced on site or replaced.

From day two through the conclusion of this warranty period, portable units must be taken to or sent prepaid to the APW Wyott Authorized Service Agency for in-warranty repairs. No mileage or travel charges are allowed on portable units after the first day of use. If the customer wants on-site service, they may receive same by paying the travel and mileage charges. Exceptions to this rule: (1) countertop warmers and cookers, which are covered under the Enhanced Warranty Program, and (2) toasters or rollergrills which have in store service.

### Exclusions

The following conditions are not covered by warranty:

- \*Equipment failure relating to improper installation, improper utility connection or supply and problems due to ventilation.
- \*Equipment that has not been properly maintained, calibration of controls, adjustments, damage from improper cleaning and water damage to controls.
- \*Equipment that has not been used in an appropriate manner, or has been subject to misuse or misapplication, neglect, abuse, accident, alteration, negligence, damage during transit, delivery or installation, fire, flood, riot or act of god.
- \*Equipment that has the model number or serial number removed or altered.

If the equipment has been changed, altered, modified or repaired by other than an Authorized Service Agency during or after the warranty period, then the manufacturer shall not be liable for any damages to any person or to any property, which may result from the use of the equipment thereafter.

This warranty does not cover services performed at overtime or premium labor rates. Should service be required at times which normally involve overtime or premium labor rates, the owner shall be charged for the difference between normal service rates and such premium rates. APW Wyott does not assume any liability for extended delays in replacing or repairing any items beyond its control.

In all cases, the use of other than APW Wyott Authorized OEM Replacement Parts will void this warranty.

This equipment is intended for commercial use only. Warranty is void if equipment is installed in other than commercial application.

### Water Quality Requirements

Water supply intended for a unit that has in excess of 3.0 grains of hardness per gallon (GPG) must be treated or softened before being used. Water containing over 3.0 GPG will decrease the efficiency and reduce the operation life of the unit.

**Note: Product failure caused by liming or sediment buildup is not covered under warranty.**

**"THE FOREGOING WARRANTY IS IN LIEU OF ANY AND ALL OTHER WARRANTIES EXPRESSED OR IMPLIED INCLUDING ANY IMPLIED WARRANTY OF MERCHANTABILITY OR FITNESS FOR PARTICULAR PURPOSES AND CONSTITUTES THE ENTIRE LIABILITY OF APW WYOTT. IN NO EVENT DOES THE LIMITED WARRANTY EXTEND BEYOND THE TERMS STATED HEREIN."**